

## Care and Maintenance

Your new garden furniture is a natural timber product. In order that you may prolong the life of this product we recommend that you follow the general care and maintenance advice below.

All fixings to be checked for tightness and signs of deterioration at the beginning of each season and on a regular basis.

Product should be checked regularly and re-coated with a suitable topcoat finish when required. If accidental damage occurs lightly sand and re-coat with a suitable water based wood preservative. Product can be cleaned periodically with a mild soapy detergent.

This is a natural product and therefore colour may vary slightly from piece to piece.

As a natural product it is possible that knots can work loose and sometimes fall out, also resin leakage and small cracks can appear on the woods surface. Should this happen, clean off resin, ensure any sharp edges are sanded smooth and recoat.

Products should be given suitable protection from adverse weather conditions, particularly during the winter months.

Please retain these instructions for future reference and use.

# Large Square Picnic Bench



Heavy duty, solid wood, 8 seater square table

Made from slow grown hard wearing pine

Assembly required • Overall Dimensions **W** 2200mm x **D** 2200mm

Table top **W** 1185mm x **D** 1185mm



Product Code I55872









Manufactured by:





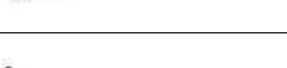

**Anchor Fast**  
Quality Garden Furniture Since 1993

# Large Square Picnic Bench

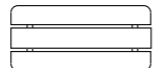

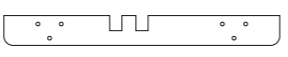
## Fixings supplied

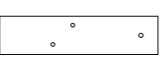
Ref	Description	Illustration	Qty
1	Zinc plated bolt ø10 x L130		4
2	Zinc plated nuts & washers ø10		20
3	Zinc plated bolt ø10 x L110		8
4	Zinc plated bolt ø8 x L80		8
5	Zinc plated nuts & washers ø8		8
6	Zinc plated allen bolt ø6 x L60		16
7	Zinc plated bolt ø10 x L150		4
8	Zinc plated bolt ø10 x L180		4

## Parts supplied

Ref	Description	Illustration	Qty
A	Table top assembly		1
B	Seat assembly		4
C	Top table x-member		2
D	Bottom table x-member		2
E	Table Legs		4
F	Seat legs		8
G	Seat leg x-member		4

## Tools included / Required

Ref	Description	Illustration	Qty
9	17mm/13mm Box Spanner		1
10	Allen Key		1
11	X-Bladed Screwdriver	Required	1

## Before you start

- It will take **two** people to assemble this product
- Check the packs and make sure you have all of the parts listed above. If not call our helpline
- Use cardboard packaging to protect surfaces during assembly
- Only tighten fully when all components are aligned in place
- Always site on firm level ground

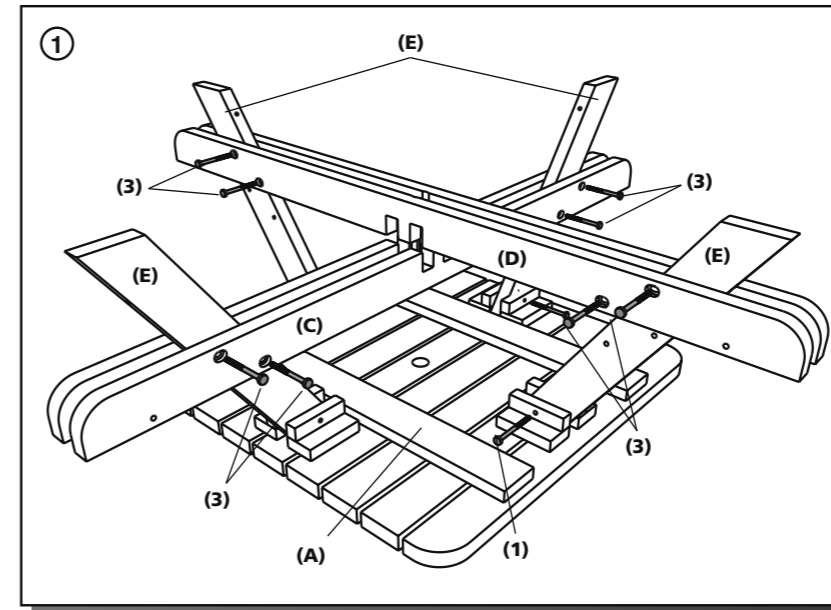
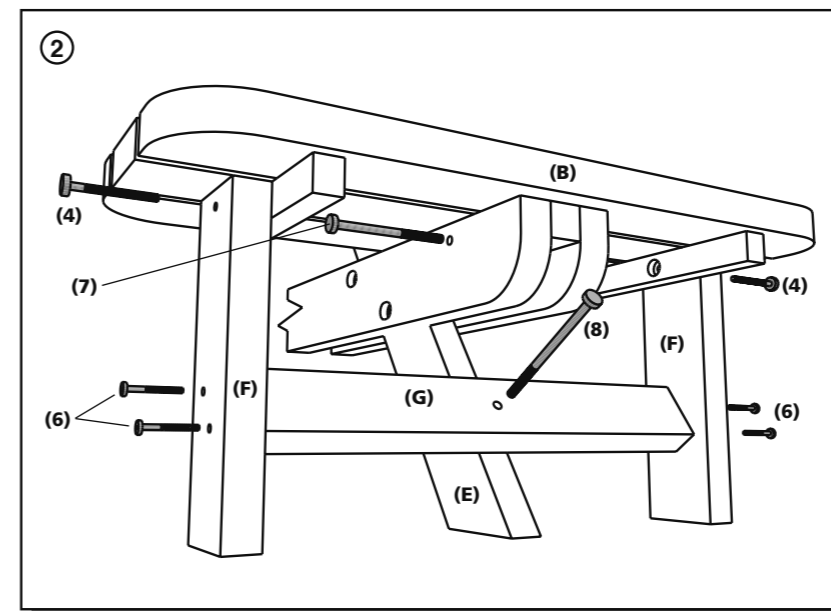

**Diagram 1**

Place table top assembly (A) face down using cardboard packaging to protect the surface.

Fix 4 x table legs (E) to table top (A) using 4 x fixings (1) and (2). Fit top table x-members (C) to table legs (E) using 4 x fixings (3) and (2), slot bottom table x-members (D) into top table x-members (C) and fix to table legs (E) using 4 x fixings (3) and (2).

Turn table over REQUIRES minimum two people.



**Diagram 2**

Fix 2 x seat legs (F) to 1 x seat leg x-member (G) using 4 x fixings (6).

Fix 1 x seat assembly (B) to seat legs (F) using 2 x fixings (4) and (5). Fit completed seat assembly to table x-members (C) and (D) using 1 x fixing (7) and (2).

Fit seat leg x-members (G) to table leg (E) using 1 x fixing (8) and (2).

Repeat diagram 2 instructions for all 4 seats.