



Assembly Instructions

Feria Patio Cover - SideWall 3

Approx. Dim.

264Lx3.4Wx285-305Hcm / 104"Lx1.3"Wx112.2-120"H

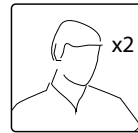
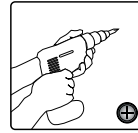
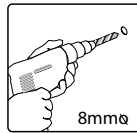
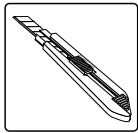
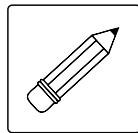
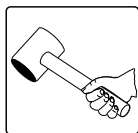
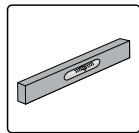
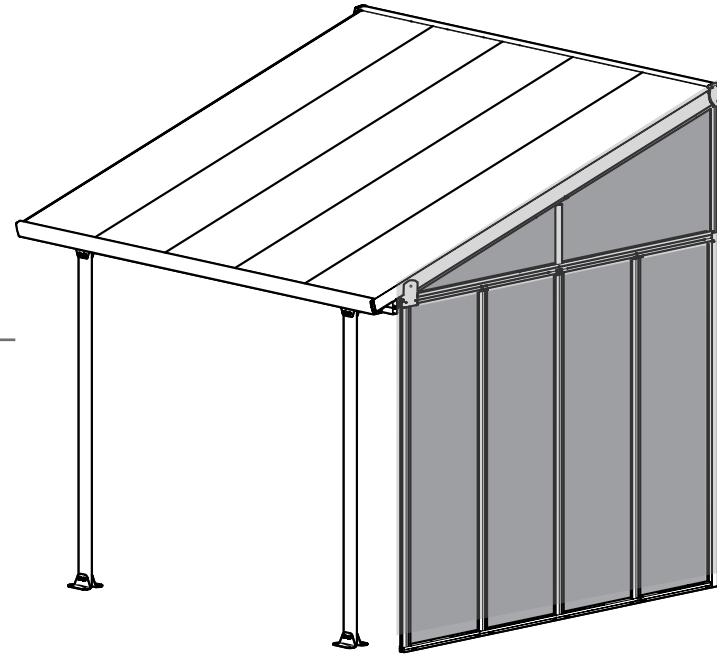

After Sale Service

Email: customer.service@palram.com

USA 877-627-8476
Canada 1 800-866-5749

England 01302-380775
Germany 0180-522-8778

France 0169-791-094
International +972 4-848-6942

www.palramapplications.com



Please read these instructions carefully before you start to assemble this product.
Please carry out the steps in the order set out in these instructions.
Keep these instructions in a safe place for future reference.



When encountering the information icon, please refer to the relevant assembly step for additional comments and assistance.

You will need

To assemble this product (these items not supplied)



Safety

- Some parts may have sharp edges. Please be careful when handling components.
- Always wear gloves, eye protection, and long sleeves when assembling or performing any maintenance on your product.
- Do not attempt to assemble the product in windy or wet conditions.
- To prevent injuries, do not allow children to play under the product during assembly.
- Do not climb or stand on the roof.
- Some versions of this product are painted.
If color was scratched during assembly it can be fixed with the following tints:
White – RAL 9016

Before Assembly

- This product is suitable for Palram's Patio Covers range
- Please consult your local authorities if any permits are required to construct the product.
- It is highly recommended to be assisted by a second person in some steps.
- Sort the parts and check according to the contents parts list.
- This product is suitable for Palram's Patio Covers range
- This product must be assembled on a solid base (such as concrete or asphalt) and anchored to the ground.
- Choose your site carefully before beginning assembly. Make sure that the mounting surface is leveled and clean from sharp objects in order to prevent scratches or damages to the product.
- Prior to the Extension installation, several parts from the Patio cover needs to be dismantle, it is recommend to keep them in a safe place for future need.

During Assembly

- These instructions mainly refer to the assembly of the SideWall on the right side of the patio cover. Assembly of the SideWall on the left side of the patio cover is possible taking the same steps.
- In several steps "**Option 1**" or "**Option 2**" notifications represent the assembly side selection. "**Option 1**" refers to assembly on the left side while "**Option 2**" refers to the right.
- While mounting the frame structure to back wall or floor the application of silicone sealant is needed in order to ensure maximal sealing.

Step 3 : Please follow "**Option 1**" or "**Option 2**" according to the side you chose to mount the SideWall.

Step 4 : Please attach #7463 with part #7482 already attached to the wall.

Step 6 : please attach part #7482 with #7463 as illustrated in drawing 6a.

Step 7 : It is important to assemble the holes outwards in order to allow the water draining out.

Step 20 : Please follow "**Option 1**" or "**Option 2**" according to the side you chose to mount the SideWall.

Use part #7514 when installing the SideWall on the left side of the patio cover.

Use part #7485 when installing the SideWall on the right side of the patio cover.

Step 21 : Please follow "**Option 1**" or "**Option 2**" according to the side you chose to mount the SideWall.

Step 36 : Application of silicone sealant is possible if necessary.

Step 39 : It is possible to trim the panel to desired size if needed.

Step 41 : Please insert the sealing rubber (#7473) at the same time; on both sides of the panel as described in drawing 41b.

Step 45 : Please use the leftovers of sealing rubber (#7473) from **step 41**.



Anmerkung: Bitte lesen Sie diese Anleitungen sorgfältig durch, bevor Sie mit dem Aufbau dieses Produktes beginnen. Bitte führen Sie die Schritte aus, wie sie in der Reihenfolge dieser Anleitung angegeben werden. Bewahren Sie diese Anleitung an einem sicheren Ort auf für späteres Nachschlagen



Wenn Sie dieses Infozeichen Begegnen, dann achten Sie bitte bei dem entsprechenden Montageschritt auf zusätzliche Kommentare und Helfende Zusatzinformation

Sie benötigen

Sie benötigen folgendes für den Aufbau dieses Produktes

(Diese Gegenstände sind nicht enthalten).



Sicherheit

- Einige Teile haben scharfe Kanten. Bitte gehen Sie beim Anfassen der Teile vorsichtig vor.
- Tragen Sie beim Aufbau oder beim Arbeiten an dem Produkt stets Augenschutz und lange Ärmel. Tragen Sie immer Handschuhe, Schuhe und Schutzbrille bei der Montage.
- Versuchen Sie nicht, das Produkt in windigem oder regnerischem Wetter zu montieren.
- Um Unfälle zu vermeiden sollten Kinder davon abgehalten werden unter dem Produkt zu spielen..
- Steigen oder stehen Sie nicht auf dem Dach.
- Einige Versionen dieses Produkts sind lackiert. Sollte die Farbe bei der Montage verkratzen, kann es mit den folgenden Farben nachlackiert werden: Weiss - RAL 9016

Bevor Sie anfangen

- Dieses Produkt eignet sich für alle Pergolen der Firma Palram
- Fragen Sie bei Ihrer örtlichen Behörde nach, ob irgendwelche Genehmigungen erforderlich sind, um das Produkt zu konstruieren.
- Es wird dringend empfohlen, von einer zweiten Person in einigen Schritten assistiert zu werden.
- Sortieren Sie die Teile aus und prüfen Sie diese nach dem Inhaltverzeichnis.
- Dieses Produkt muss auf einer festen Unterlage (z.B. Beton) montiert werden.
- Wählen Sie Ihren Ort sorgfältig aus, bevor Sie mit der Montage beginnen.
- Als Untergrund sollte eine ebene Fläche gewählt werden (vorallem unterhalb der Pfosten).
- Bei der Montage nehmen Sie eine weiche Plattform und stellen Sie diese unterhalb der Teile, um Kratzer und Beschädigungen zu vermeiden.

Während des Zusammenbaus

- Diese Instruktionen beziehen sich auf die Installation der Seitenwand auf der rechten Seite der Patio – Überdachung, ist die Installation auf der linken Seite kann gemäß gleicher Schritte fortgesetzt werden.
- Bei manchen Schritten, kann bei der Meldungen "**Option 1**" oder "**Option 2**" die Montageseite entsprechend ausgewählt werden. "**Option 1**" bezieht sich auf die Montage auf der linken Seite, während "**Option 2**" bezieht sich auf der rechten Seite
- Bei der Montage der Rahmenstruktur an der hinteren Wand oder am Boden, ist die Anwendung von Silikon erforderlich, um eine maximale Abdichtung zu gewährleisten.

Schritt 3 : Bitte befolgen Sie "**Option 1**" oder "**Option 2**" entsprechend der Seite, die Sie gewählt haben, um die Seitenwand zu montieren.

Schritt 4 : Bitte fügen Sie das Teil #7463 mit dem bereits an der Wand befestigten Teil #7482 zusammen.

Schritt 6 : Bitte fügen Sie das Teil # 7482 mit dem Teil # 7463, wie in Zeichnung 6a dargestellt wird, zusammen.

Schritt 7 : Es ist wichtig die Teile mit den Löchern nach außen zu montieren, damit das Wasser abgeleitet werden kann.

Schritt 20 : Bitte befolgen Sie "**Option 1**" oder "**Option 2**" entsprechend der Seite, die Sie gewählt haben, um die Seitenwand zu montieren
#7514 = Linken Seite
#7485 = Rechten Seite

Schritt 21 : Bitte befolgen Sie "**Option 1**" oder "**Option 2**" entsprechend der Seite, die Sie gewählt haben, um die Seitenwand zu montieren.

Schritt 36 : Die Anwendung von Silikon ist ggf. möglich.

Schritt 39 : Es ist möglich, die Paneele in der gewünschten Größe zu trimmen, wenn nötig.

Schritt 41 : Legen Sie die Gummidichtung (# 7473) gleichzeitig auf beide Seiten des Paneels wie in Zeichnung 41b beschrieben wird

Schritt 45 : Bitte verwenden Sie die Reste der Gummidichtung (# 7473) vom Schritt 41.



Lisez s'il vous plaît attentivement ces instructions avant de commencer assembler ce produit. Veuillez s'il vous plaît exécuter les étapes d'assemblage dans l'ordre défini dans ces instructions. Conservez ces instructions dans un endroit sûr pour référence ultérieure.



Lorsque vous rencontrez l'icône d'information, veuillez vous référer à l'étape d'assemblage approprié pour remarque et assistance additionnels.

Vous aurez besoin

Pour assemblage de ce produit (ces éléments ne sont fournis)



Sécurité

- Certaines pièces peuvent être coupantes. Soyez prudent lorsque vous manipulez les éléments.
- Porter toujours des gants, des lunettes de protection et des vêtements à manches longues lors de l'assemblage ou toute opération de maintenance sur votre produit.
- Ne tentez pas de monter le produit dans des conditions venteuses ou humides.
- Pour éviter les blessures ne laissez pas les enfants jouer autour et dans l'objet lors de l'assemblage.
- Ne pas grimper ou se tenir debout sur le toit.
- Certaines versions de ce produit sont peintes. Si la couleur a été rayée lors du montage ceci peut être fixe avec les teintes suivantes : Blanc – RAL 9016

Avant Assemblage

- Ce produit est adapté pour les Gamme Couvres Patio de Palram
- Consultez s'il vous plaît les autorités locales si un permis est nécessaire pour construire le produit.
- Il est vivement recommandé d'être assisté par une deuxième personne dans certaines étapes.
- Triez les pièces et vérifiez selon la liste de contenu.
- Ce produit est adapté pour les Gamme Couvres Patio de Palram
- Ce produit doit être assemblé sur une base solide (tel que du béton ou de l'asphalte) et ancré au sol.
- Choisissez attentivement votre emplacement avant de commencer le montage. Assurez-vous que la surface de montage est nivelée et propre des objets pointus afin d'éviter des rayures ou dommages au produit.
- Plusieurs parties du couvercle du patio doit être démonté avant l'installation de l'extension, il est recommandé de les garder dans un endroit sûr pour les besoins ultérieurs.

Pendant l'Assemblage

- Ces instructions se réfèrent surtout à l'assemblage de la paroi latérale du côté droit du couvre patio. Assemblage de la paroi latérale du côté gauche du couvre patio est possible en prenant les mêmes étapes.
- En plusieurs étapes notification "**Option 1**" ou "**Option 2**" représente la sélection côté de l'assemblage. "**Option 1**" se réfère à l'assemblage du côté gauche tandis que "**Option 2**" se réfère de celui de droit.
- Pendant le montage de la construction du cadre au mur ou au plancher il est nécessaire d'appliquer des matériaux de scellant de silicone pour assurer l'étanchéité maximale

Étape 3 : Veuillez suivre "**Option 1**" ou "**Option 2**" selon le côté vous avez choisi de monter le mur latéral

Étape 4 : Joignez s'il vous plaît pièce #7463 avec pièce #7482 qui est déjà fixé au mur.

Étape 6 : Joignez s'il vous plaît pièce #7482 avec pièce #7463 comme illustre dans le dessin 6a.

Étape 7 : Il est important de réunir les trous afin de permettre le drainage de l'eau.

Étape 20 : Veuillez suivre "**Option 1**" ou "**Option 2**" selon le côté vous avez choisi de monter le mur latéral.

Utilisez pièce #7514 lors de l'installation de la paroi latérale sur le côté gauche du couvre Patio.

Utilisez pièce #7485 lors de l'installation de la paroi latérale sur le côté droit du couvre Patio

Étape 21 : Veuillez suivre "**Option 1**" ou "**Option 2**" selon le côté vous avez choisi de monter le mur latéral.

Étape 36 : Application de mastic silicone est possible si nécessaire.

Étape 39 : Il est possible de découper le panneau à la taille désirée si nécessaire.

Étape 41 : Insérez s'il vous plaît caoutchouc (#7473) sur les deux côtés du panneau en même temps, comme décrit dans le dessin 41b.

Étape 45 : Utilisez s'il vous plaît les restant de caoutchouc (#7473) de l'étape 41.



Por favor, lea atentamente estas instrucciones antes de empezar a ensamblar el producto. Lleve a cabo los pasos en el orden indicado en estas instrucciones. Guarde las instrucciones en un lugar seguro para futuras consultas.



Cuando vea el icono de información, consulte el paso de montaje correspondiente para obtener comentarios adicionales y asistencia.

Lo que necesitará

Para ensamblar este producto (estos artículos no están incluidos).



Seguridad.

- Algunas piezas pueden tener bordes filosos. Tenga cuidado al manejar los componentes.
- Siempre use guantes, protección para los ojos y mangas largas cuando esté ensamblando o realizando el mantenimiento de su producto.
- No intente ensamblar el producto en condiciones de viento o humedad.
- Para evitar lesiones, no permita que los niños jueguen debajo del producto durante su montaje.
- No se trepe ni se pare sobre el techo.
- Algunas versiones de este producto vienen pintadas. Si la pintura se rasga durante el montaje, puede ser reparada con los siguientes tintes: Gris - RAL 7012

Antes del Montaje

- Este producto es compatible con la gama de Cubiertas de Patio de Palram.
- Consulte con las autoridades locales si es necesario obtener algún permiso para construir el producto.
- Es muy recomendable que sea asistido por otra persona en algunos de los pasos de la instalación.
- Ordene las piezas y verifíquelas de acuerdo con el índice de contenido.
- Este producto es compatible con la gama de Cubiertas de Patio de Palram.
- Este producto debe ser montado sobre una base sólida (como ser hormigón o asfalto) y anclado al suelo.
- Antes de comenzar el montaje, elija el sitio con cuidado. Asegúrese de que la superficie de montaje esté nivelada y libre de objetos afilados para evitar arañazos o daños al producto.
- Antes de la instalación, algunas partes de la cubierta del Patio deben ser desarmadas, se recomienda guardarlas en un lugar seguro para necesidades futuras.

Durante el Montaje

- Estas instrucciones se refieren principalmente al armado de la ParedLateral en el lado derecho de la cubierta para patios. Es posible armar la ParedLateral en el lado izquierdo de la cubierta para patios siguiendo los mismos pasos.
- Las notas "**Opción 1**" u "**Opción 2**" presentes en varios pasos representan el lado seleccionado para el armado. "**Opción 1**" se refiere al armado del lado izquierdo mientras "**Opción 2**" se refiere al lado derecho.
- Al montar la estructura del marco sobre la pared posterior o sobre el suelo, es necesario aplicar sellante de silicona para asegurar un aislamiento máximo.

Paso 3: Por favor siga la "**Opción 1**" u "**Opción 2**" según el lado en el que escoja montar la ParedLateral.

Paso 4: Por favor una la pieza #7463 a la pieza #7482 ya unida a la pared.

Paso 6: Por favor una la pieza #7482 a la pieza #7463 según se muestra en la ilustración 6a.

Paso 7: Es importante ubicar los agujeros mirando hacia afuera, para permitir el drenaje de agua.

Paso 20: Por favor siga la "**Opción 1**" u "**Opción 2**" según el lado en el que escoja montar la ParedLateral.

Utilizar parte # 7514 al instalar la pared lateral en el lado izquierdo de la cubierta del patio.

Utilizar parte # 7485 al instalar la pared lateral en el lado derecho de la cubierta del patio.

Paso 21: Por favor siga la "**Opción 1**" u "**Opción 2**" según el lado en el que escoja montar la ParedLateral.



Paso 36: Es posible aplicar sellante de silicona en caso necesario.

Paso 39: Es posible rebajar el panel para obtener el tamaño deseado en caso necesario.

Paso 41: Por favor inserte la goma aislante (#7473) en ambos lados del panel al mismo tiempo, como se describe en la ilustración 41b.

Paso 45: Por favor use los restos de goma aislante (#7473) del **paso 41**. Antes de armar



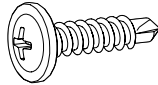
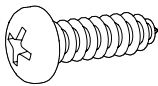
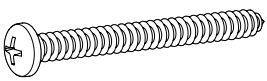
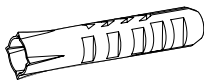

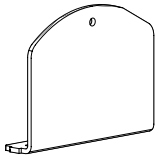
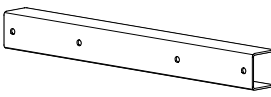
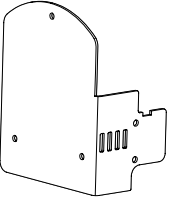
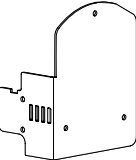
Contents

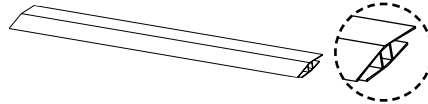
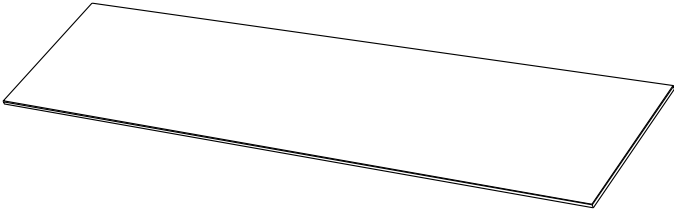
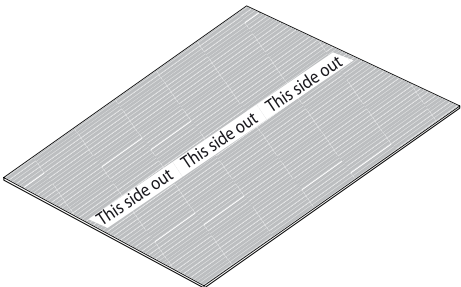
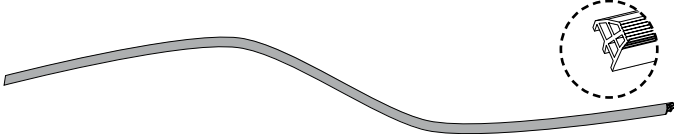
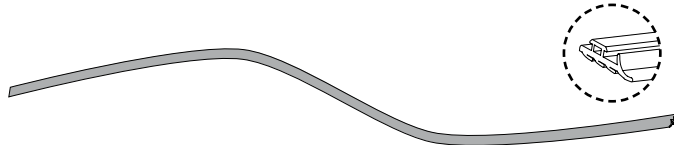

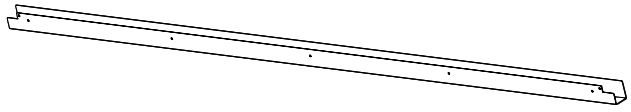

Item		Qty.
411		4 (+1)
461		6 (+1)
466		11 (+1)
4008		61 (+4)
447		2 (+1)
4006		13 (+2)
4009		13 (+2)

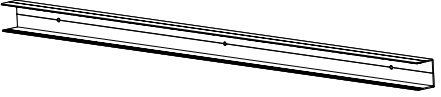
Item		Qty.
7484		1
7467		1
7514		1
7485		1

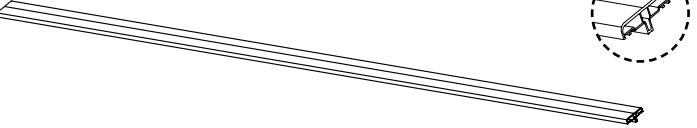
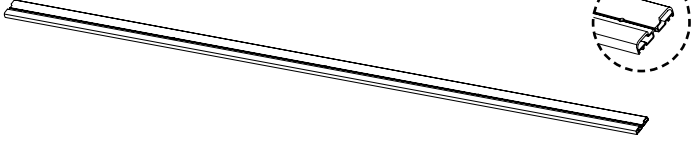
Item		Qty.
7486		1
7471		4
7472		2
7473		8
7481		20

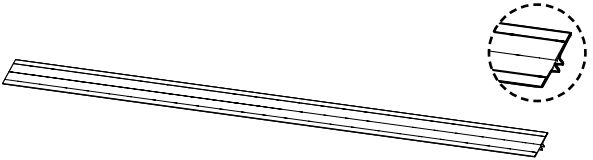
Contents

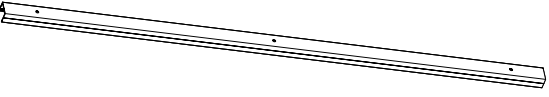
Item		Qty.
7482		1
7477		1
7476		1
7470		5
7469		5
7468		5

Item		Qty.
7466		2
7465		2
7464		2
7463		1

1

7476 1 7482 1

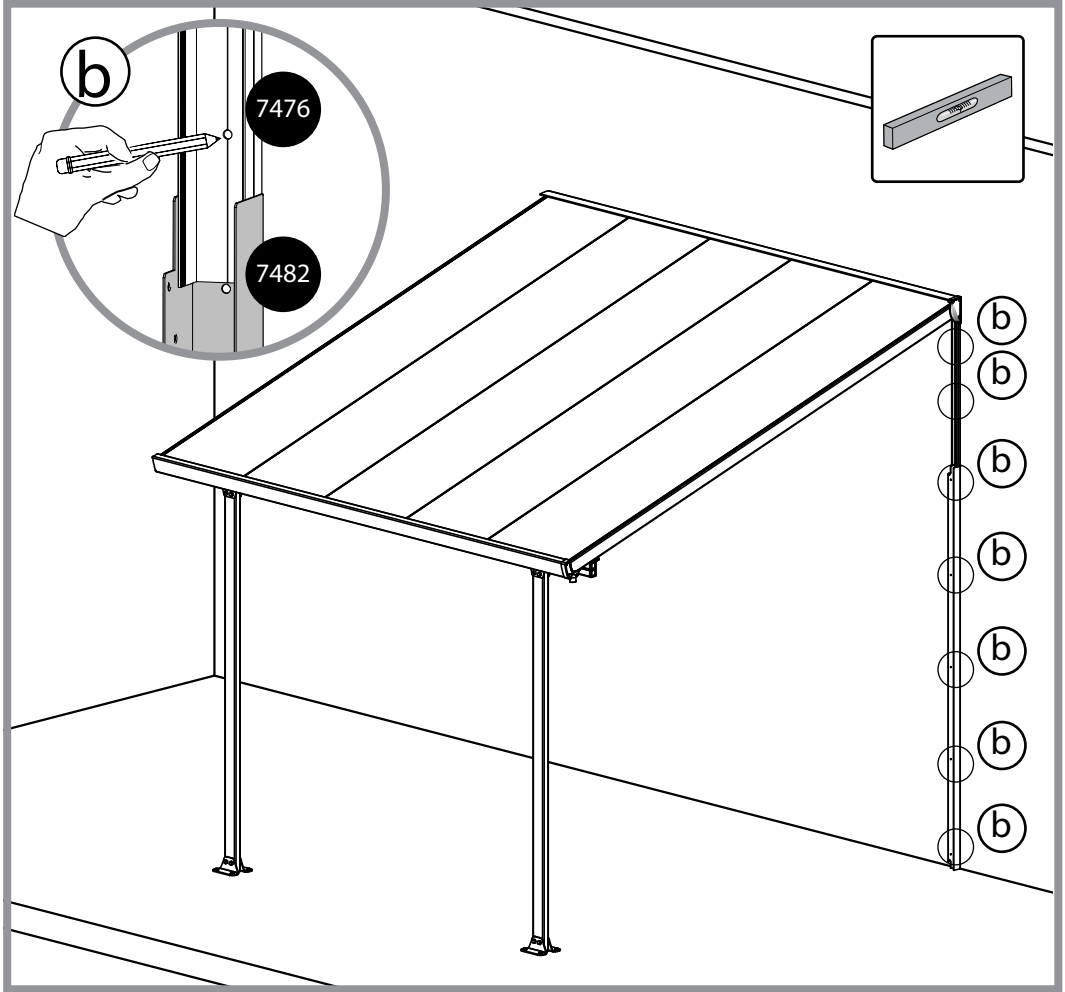
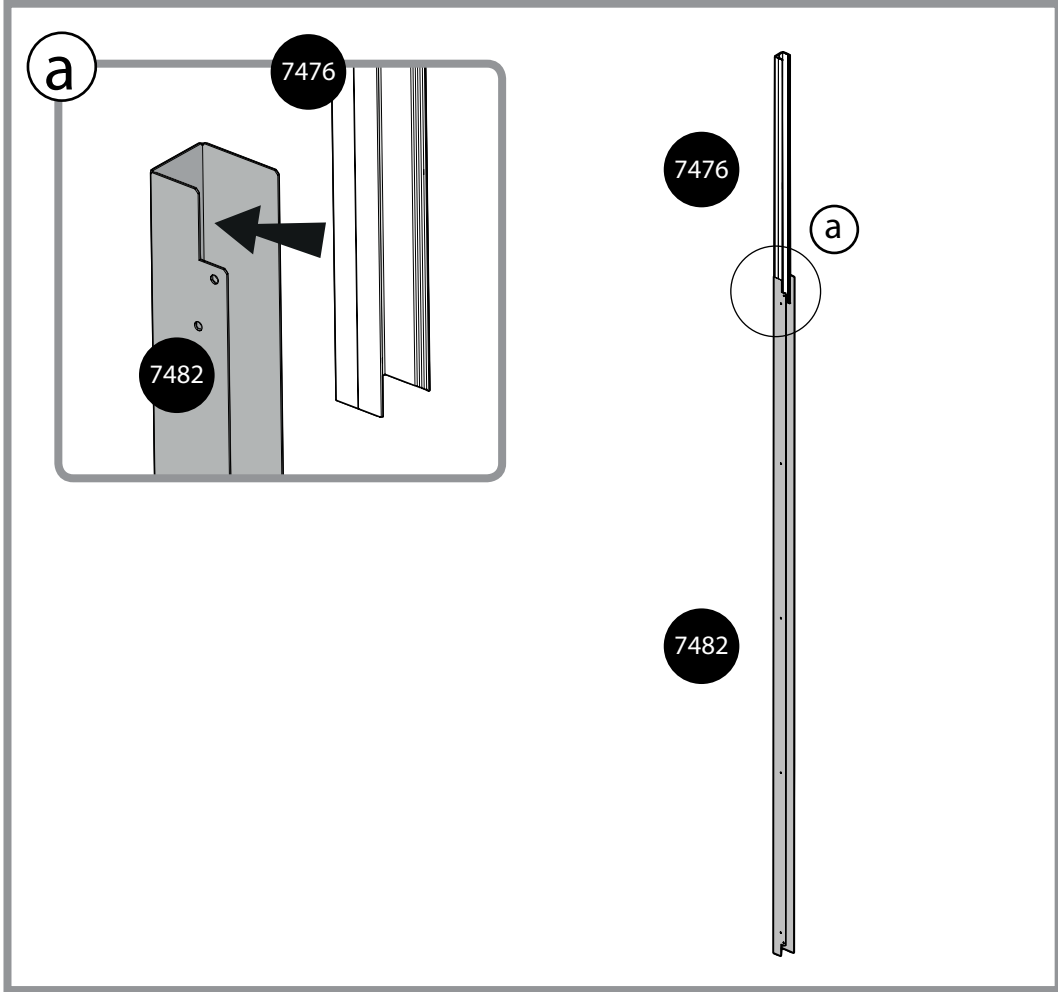

2

4009

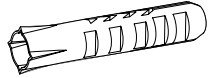

7

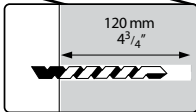
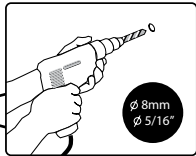
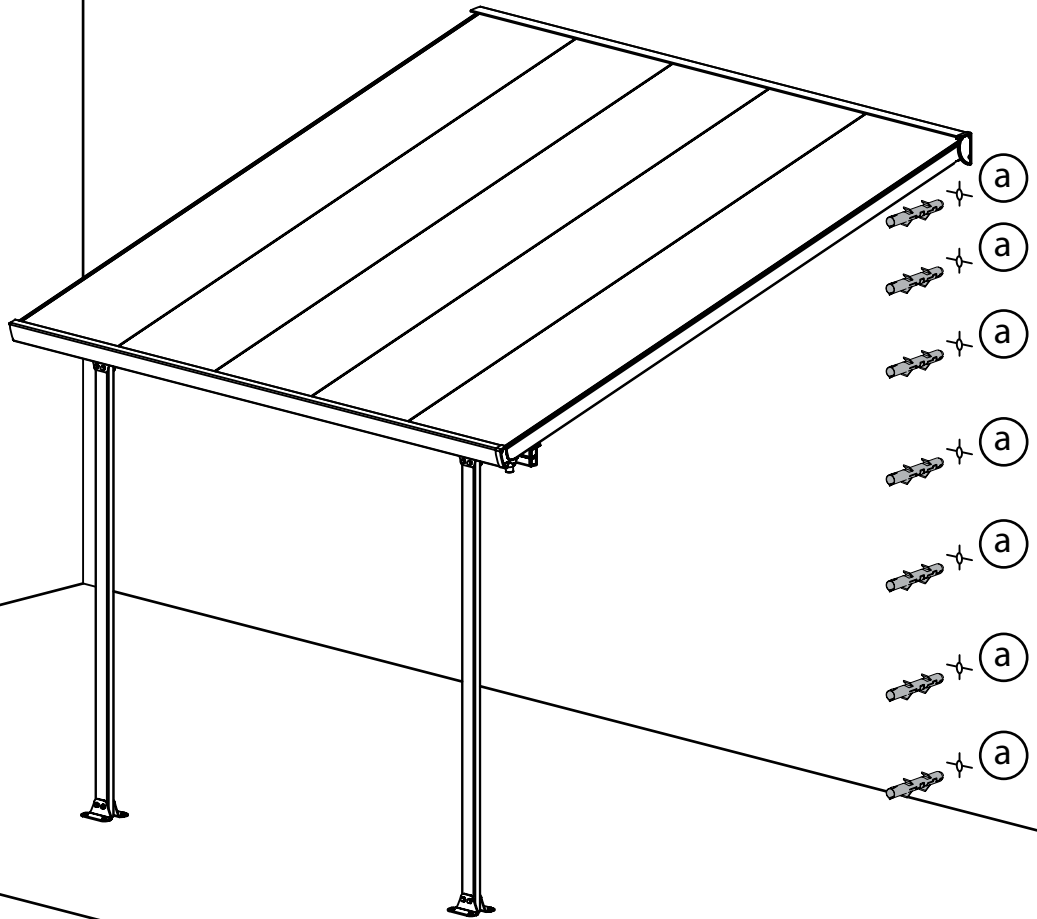
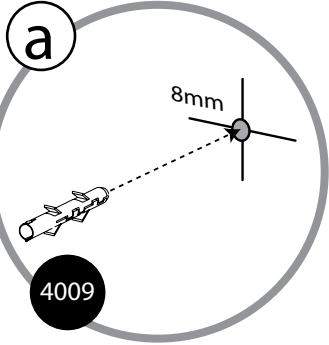

3 **i**

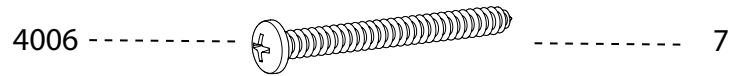

Option 1 EN-Left side | DE-Linke Seite | FR-côté gauche

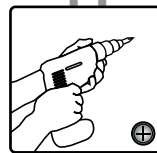
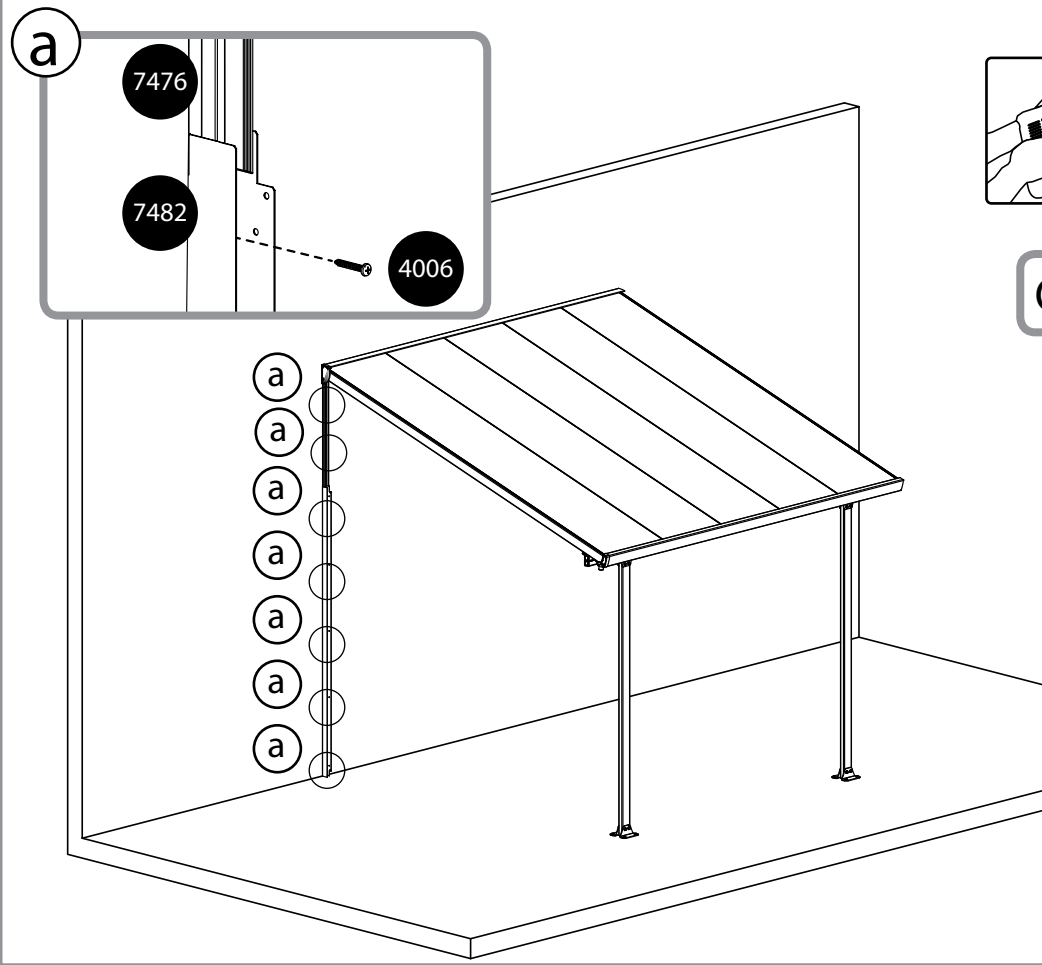

OR

Option 2 EN-Right side | DE-echte Seite | FR-côté droit

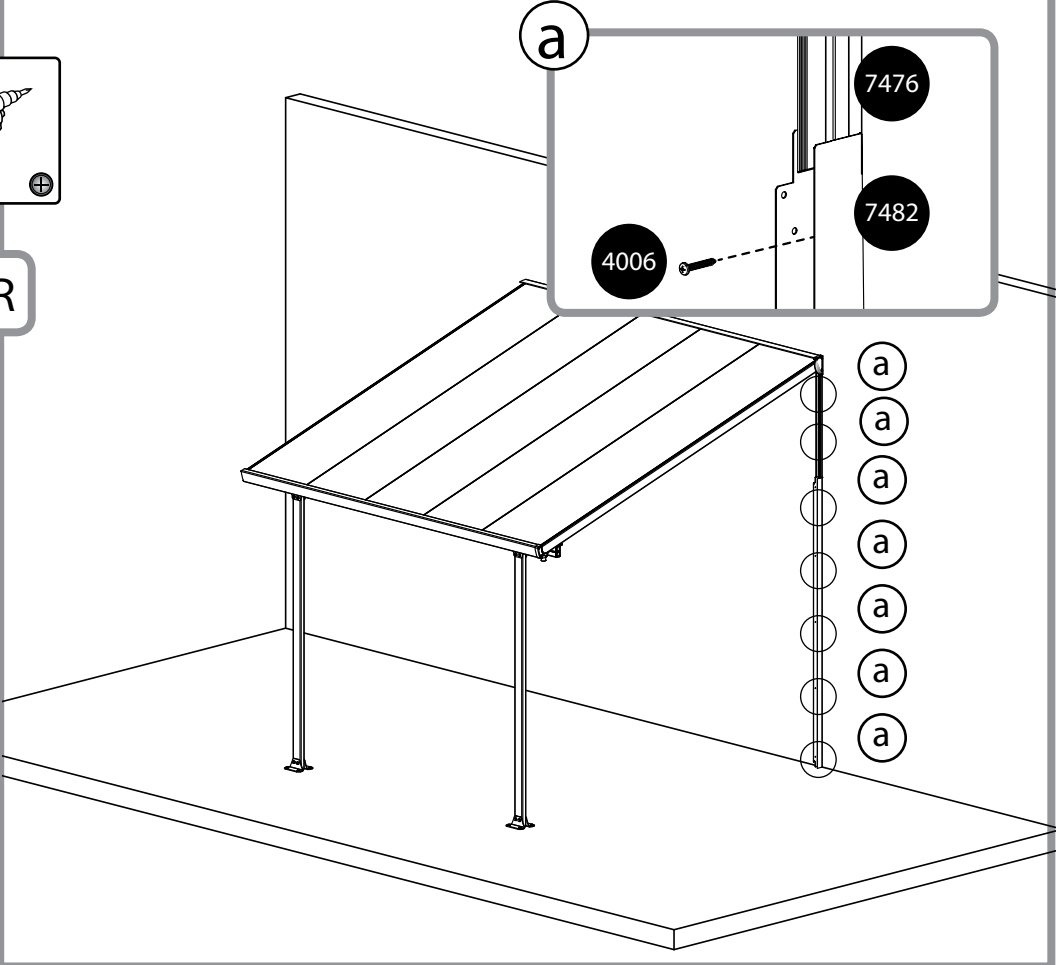

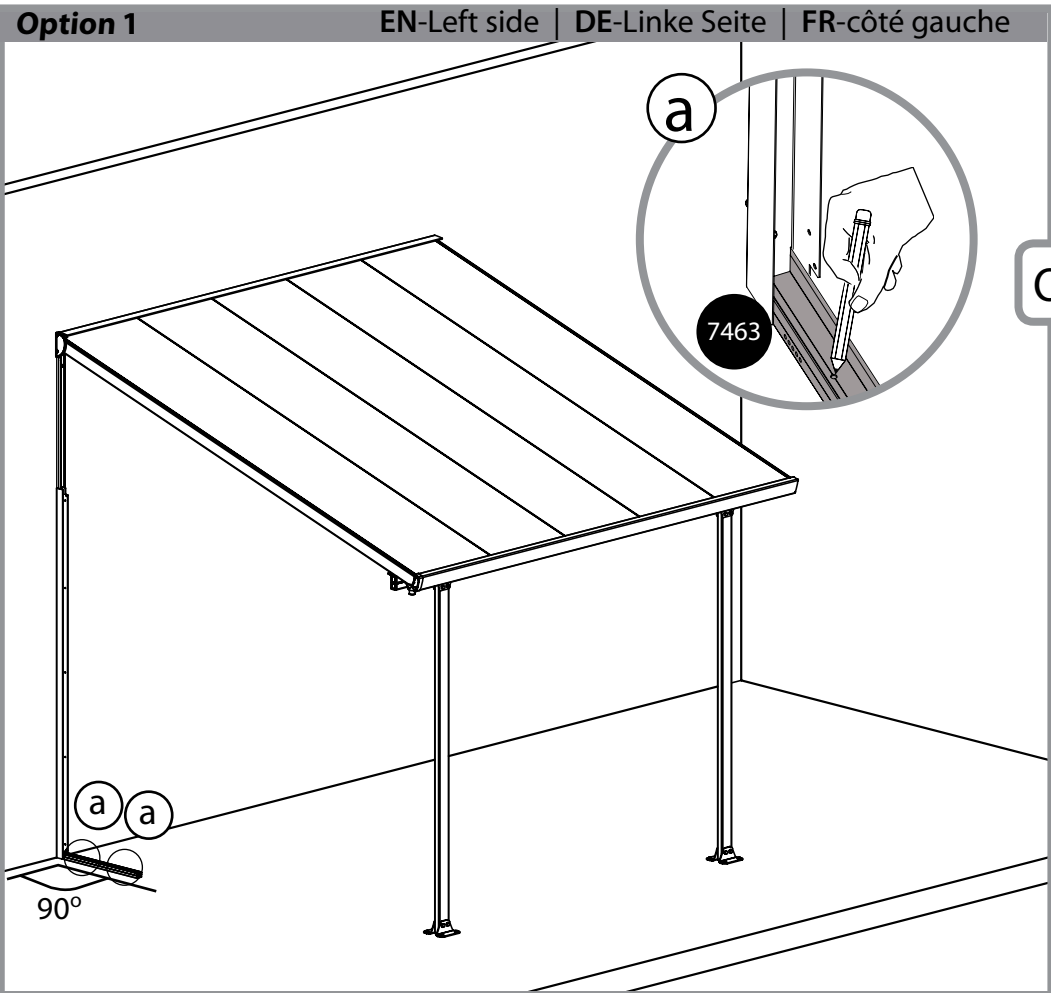

OR

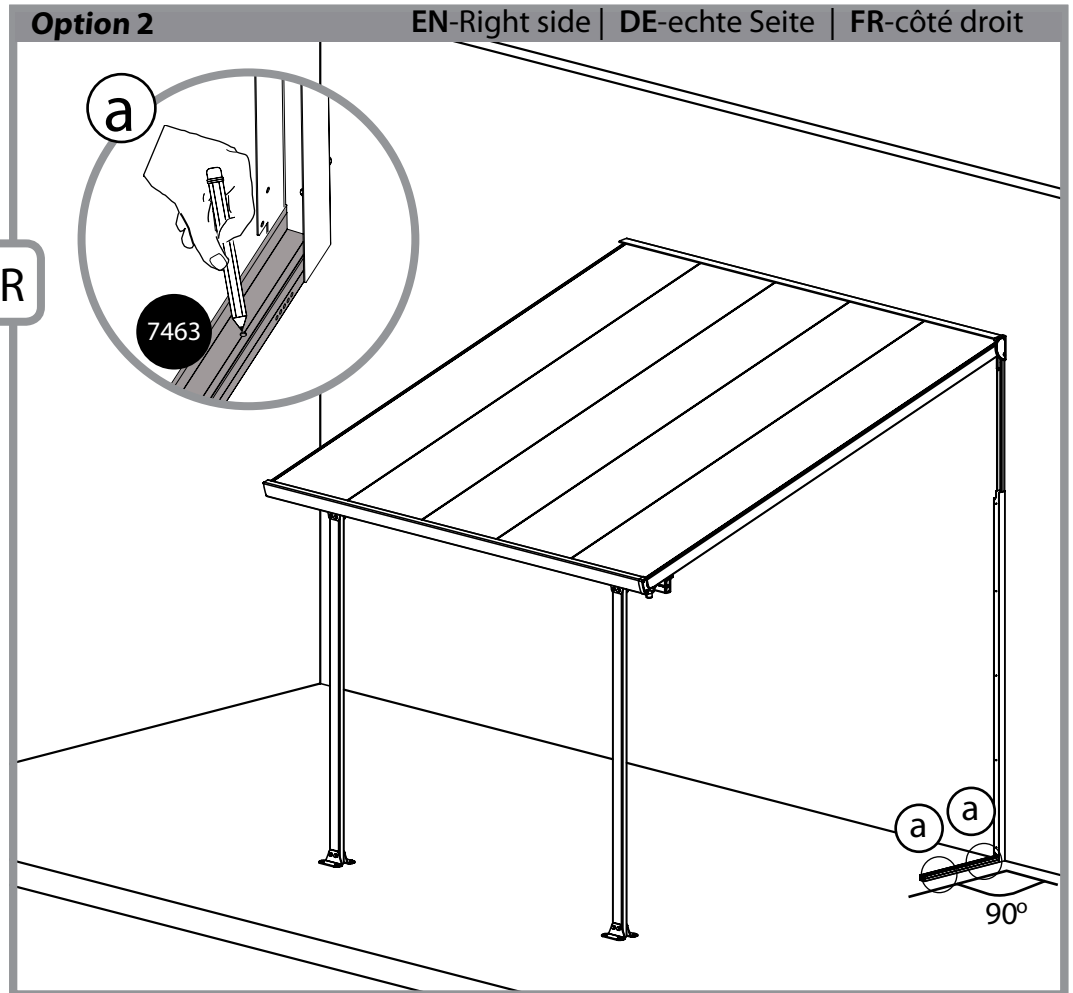

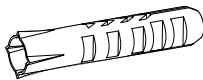
4009 -----  ----- 2

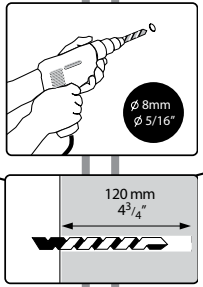
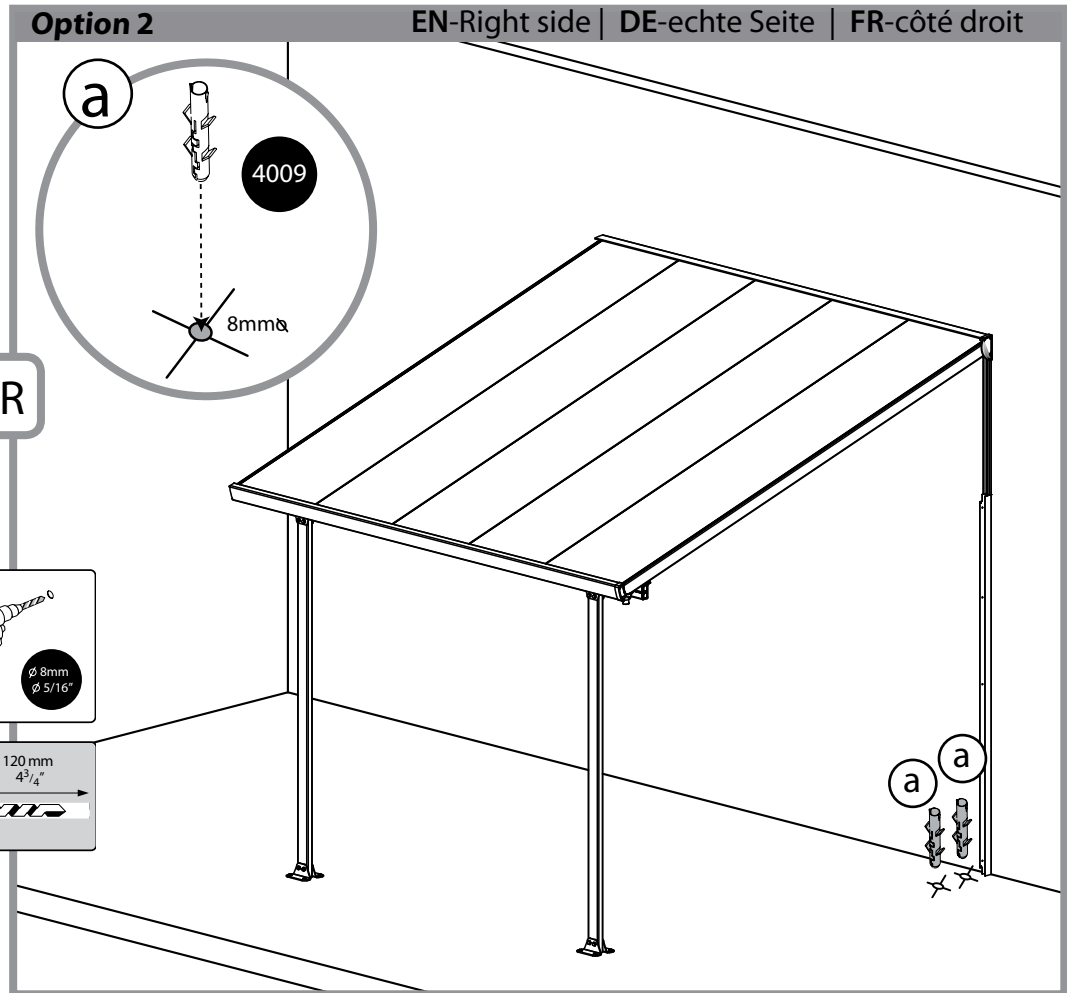
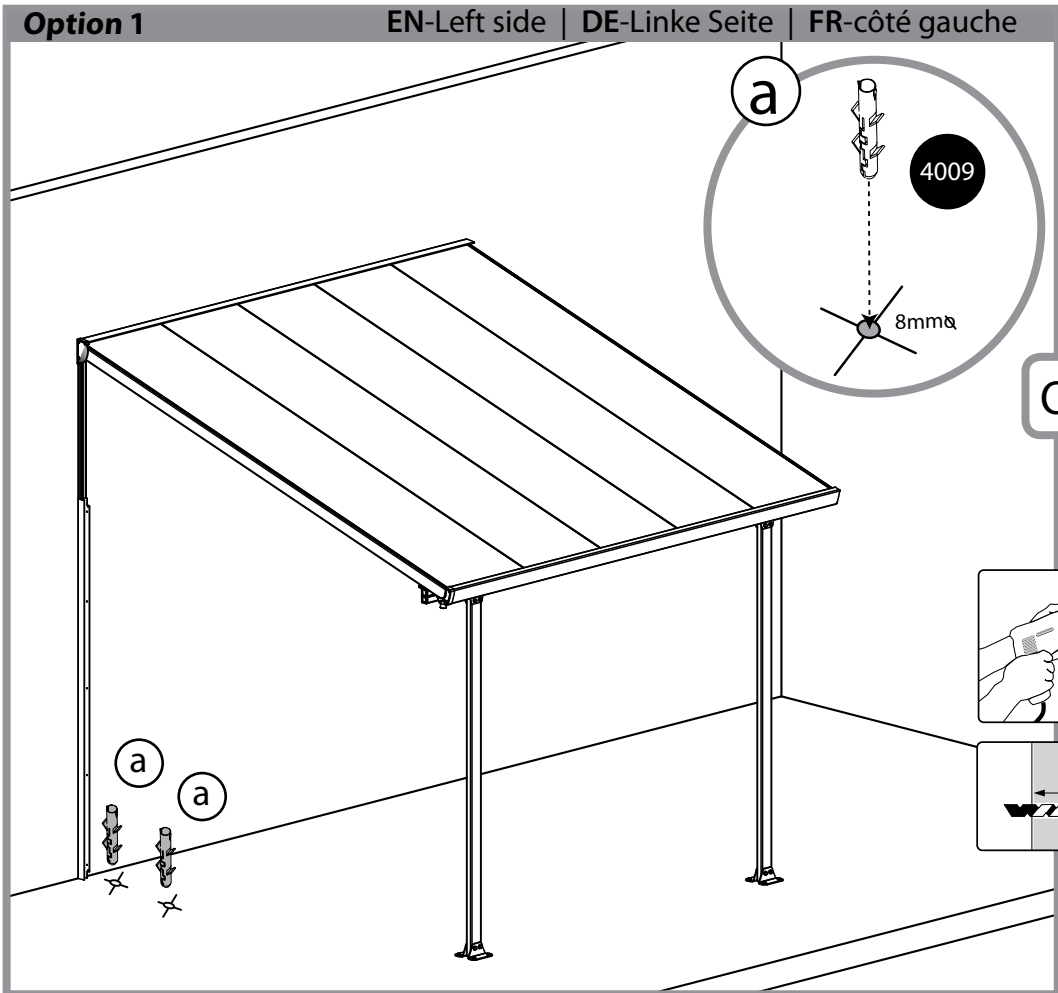

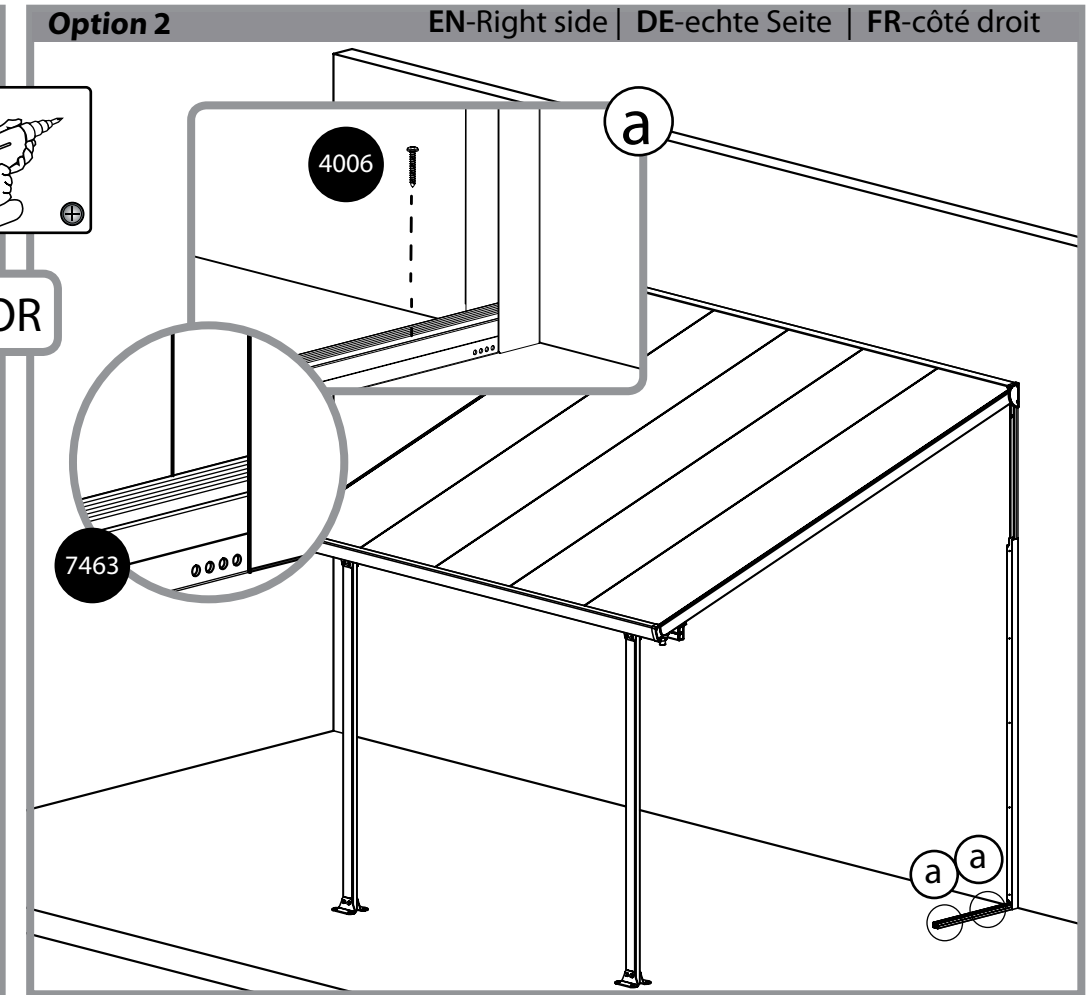
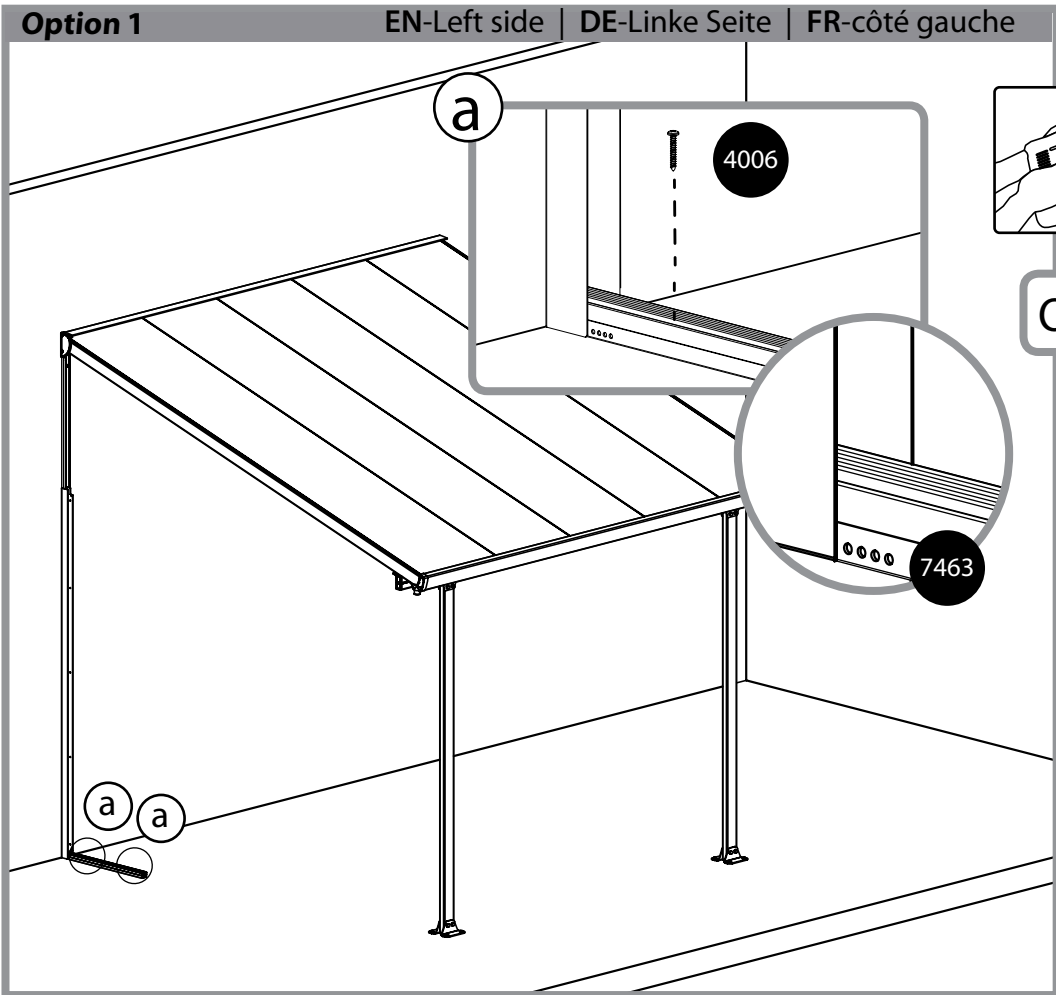
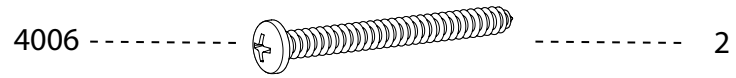



Option 1 EN-Left side | DE-Linke Seite | FR-côté gauche

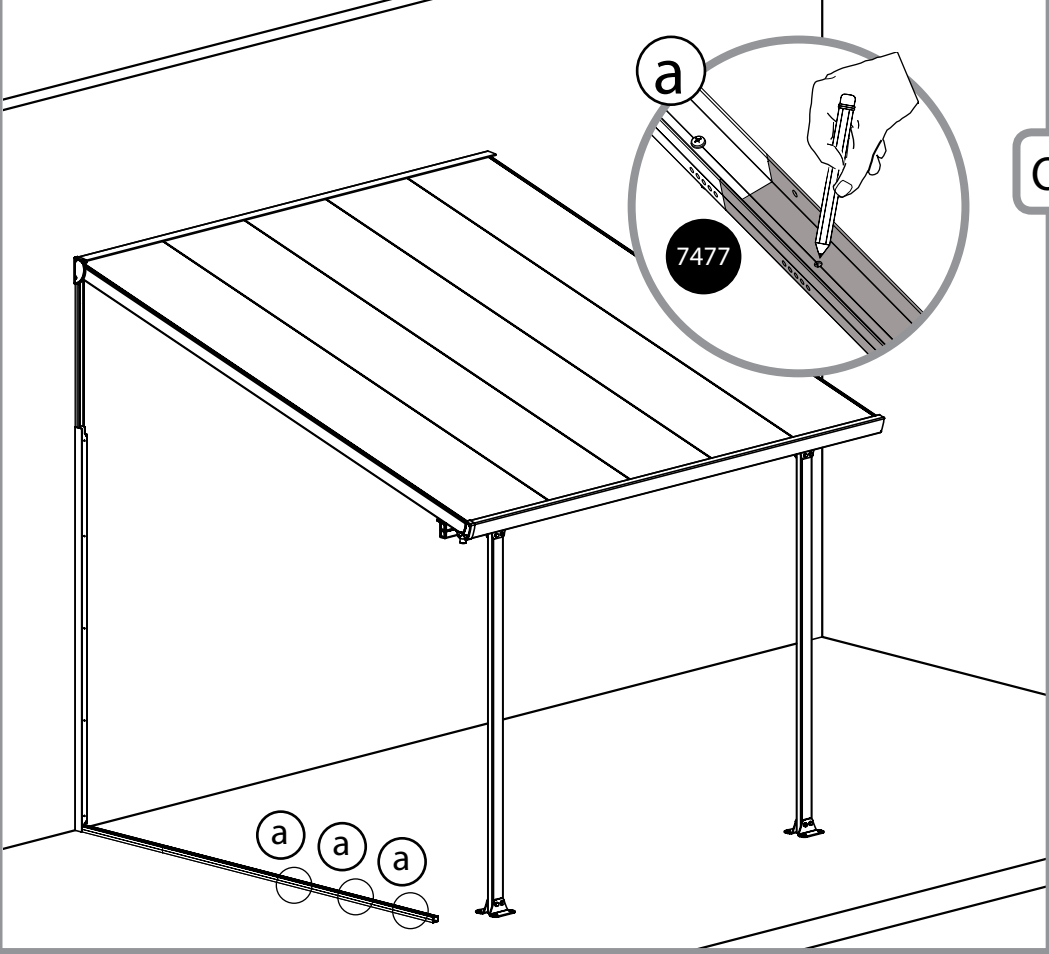

OR

Option 2 EN-Right side | DE-echte Seite | FR-côté droit

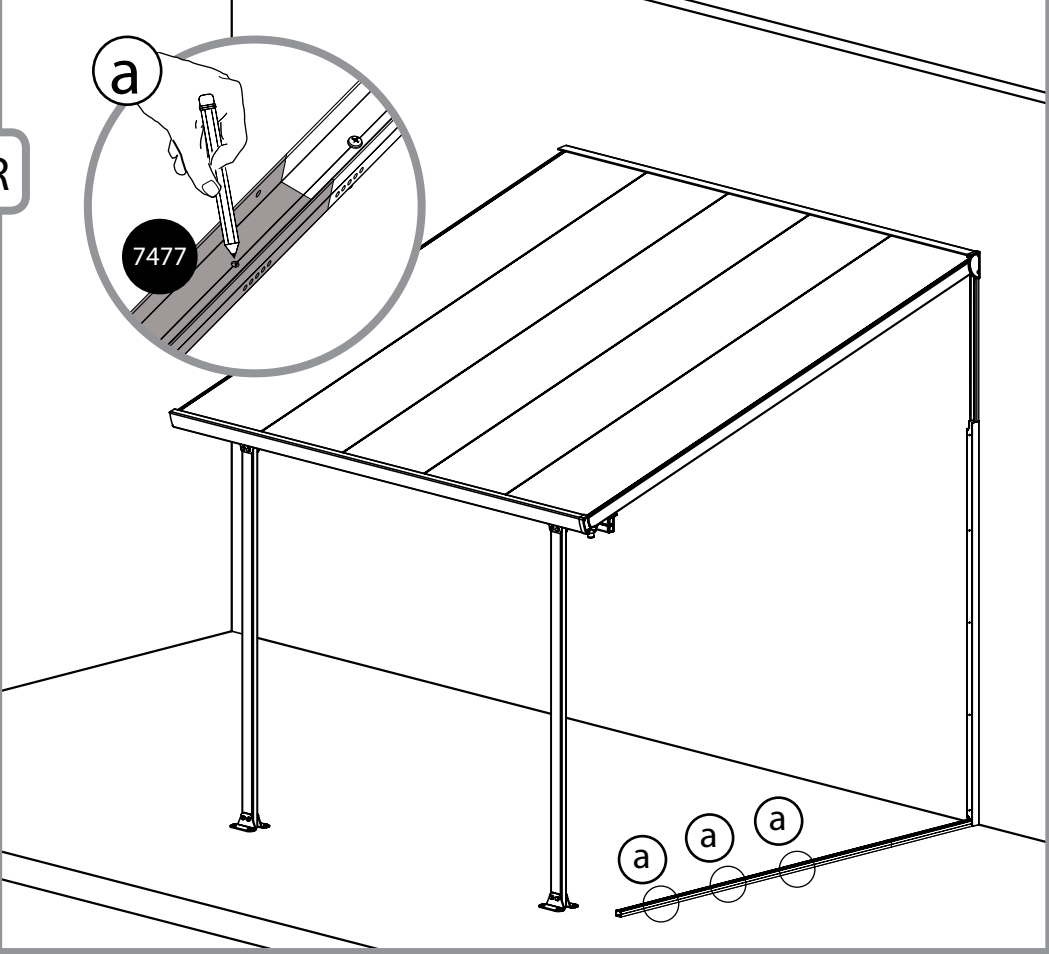

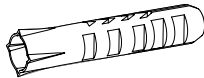
4009 -----  ----- 3

Option 1 EN-Left side | DE-Linke Seite | FR-côté gauche

Option 2 EN-Right side | DE-echte Seite | FR-côté droit

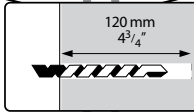
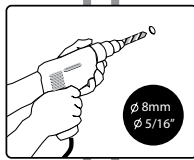
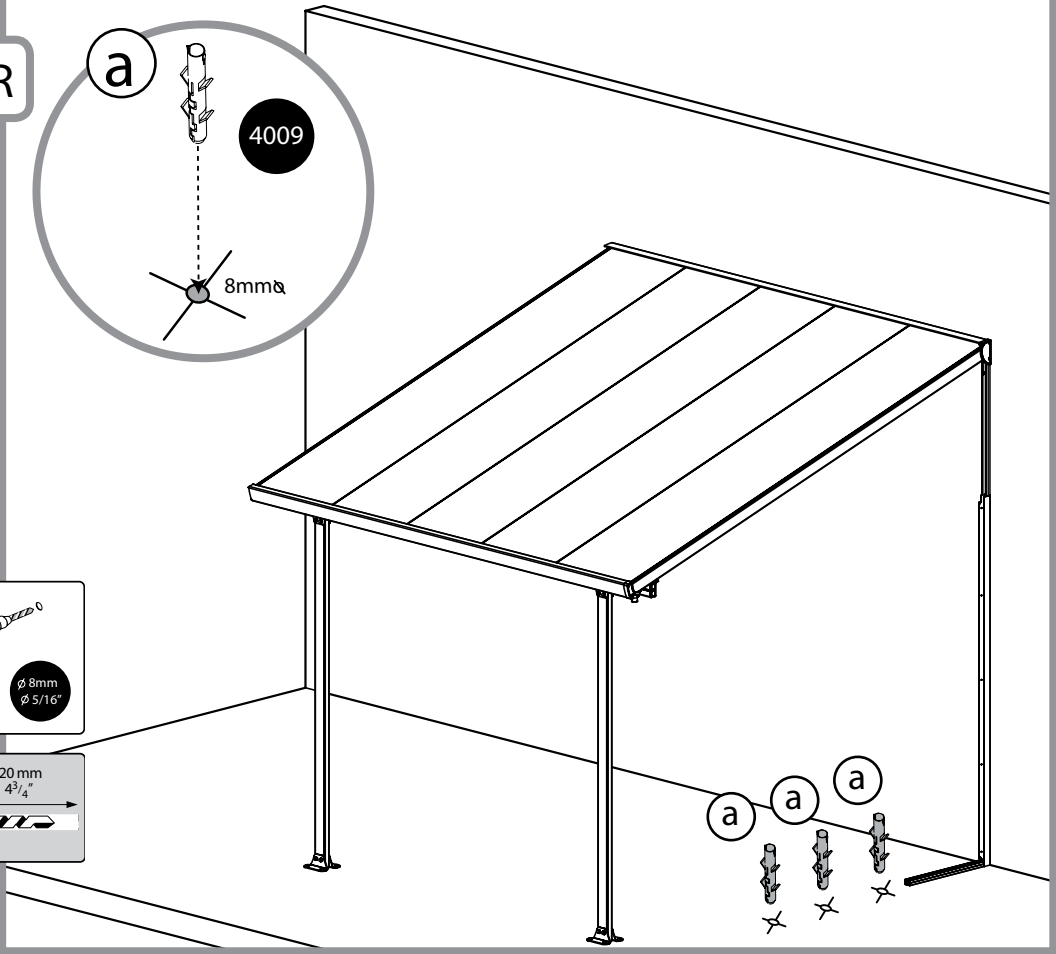
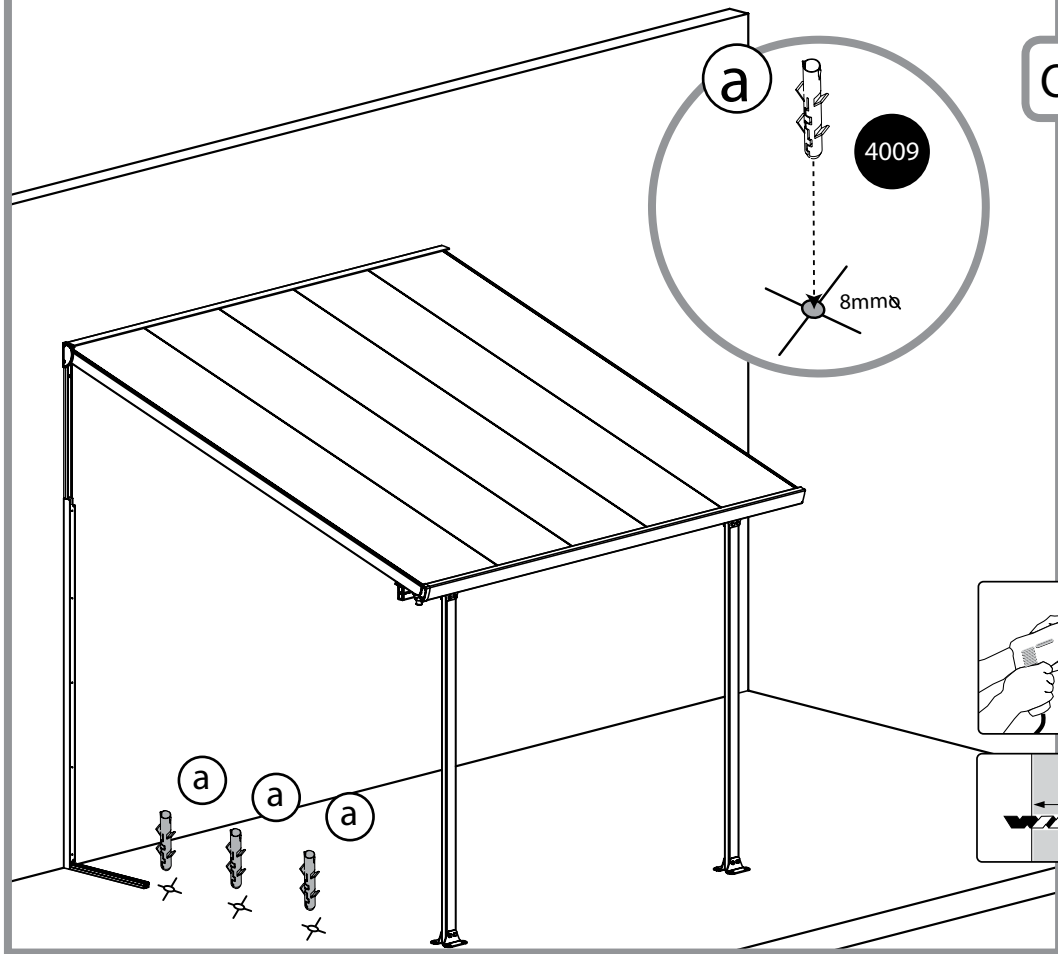

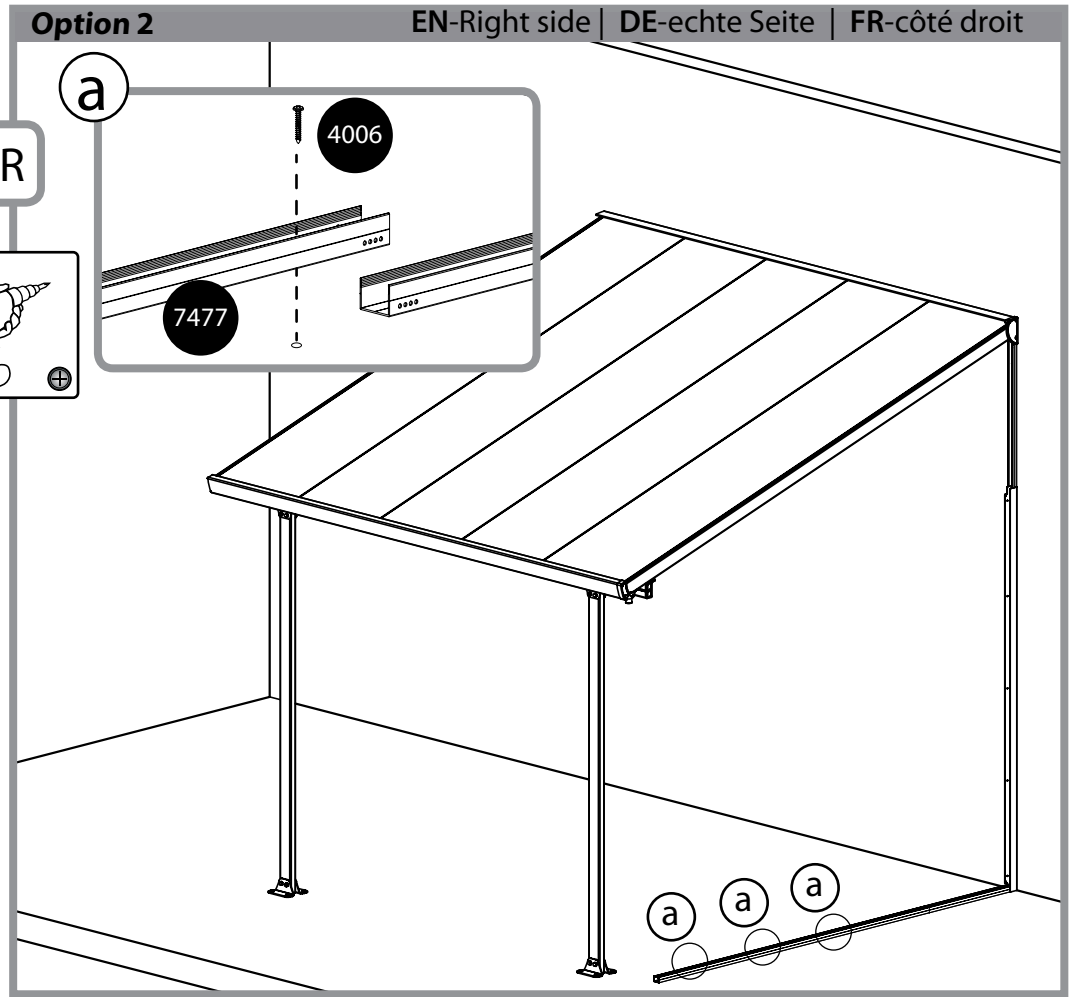
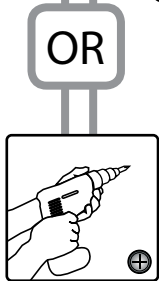
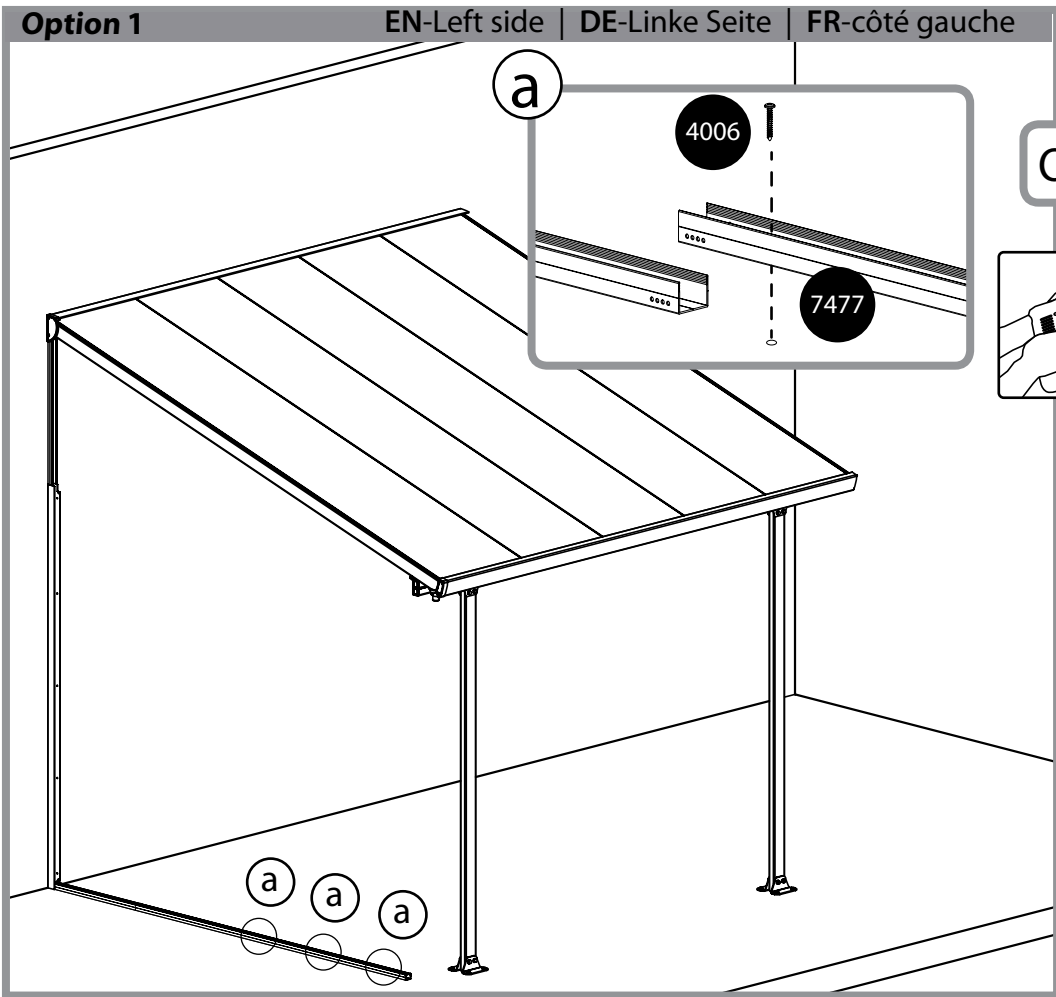
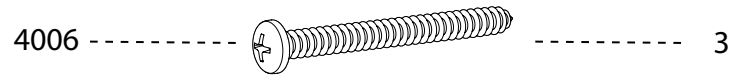

7464

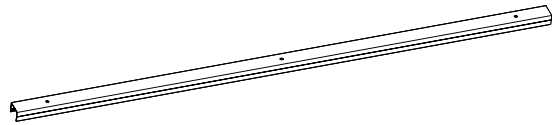

2

461



6

466



6

X2

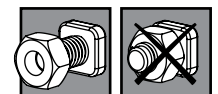
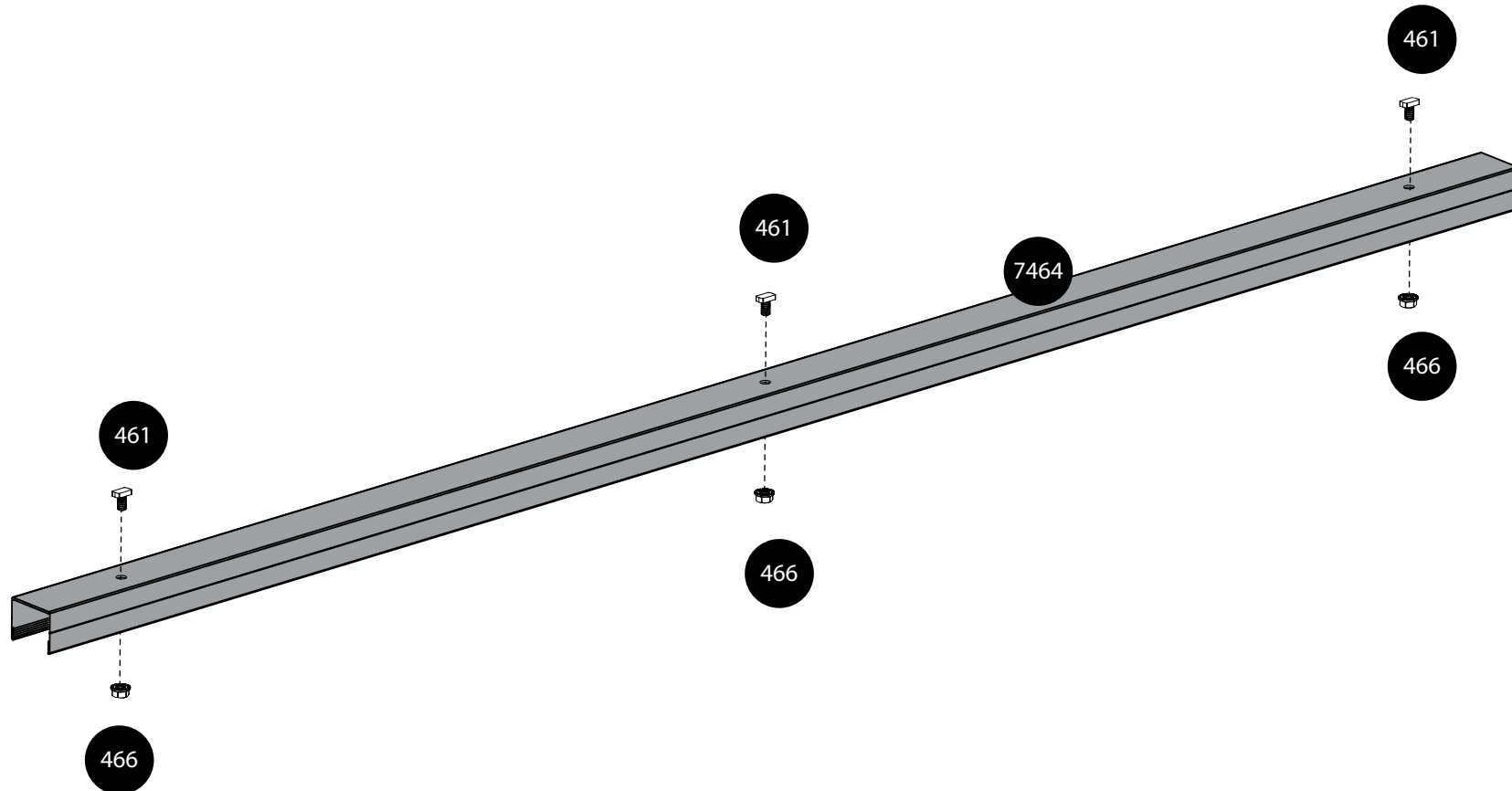

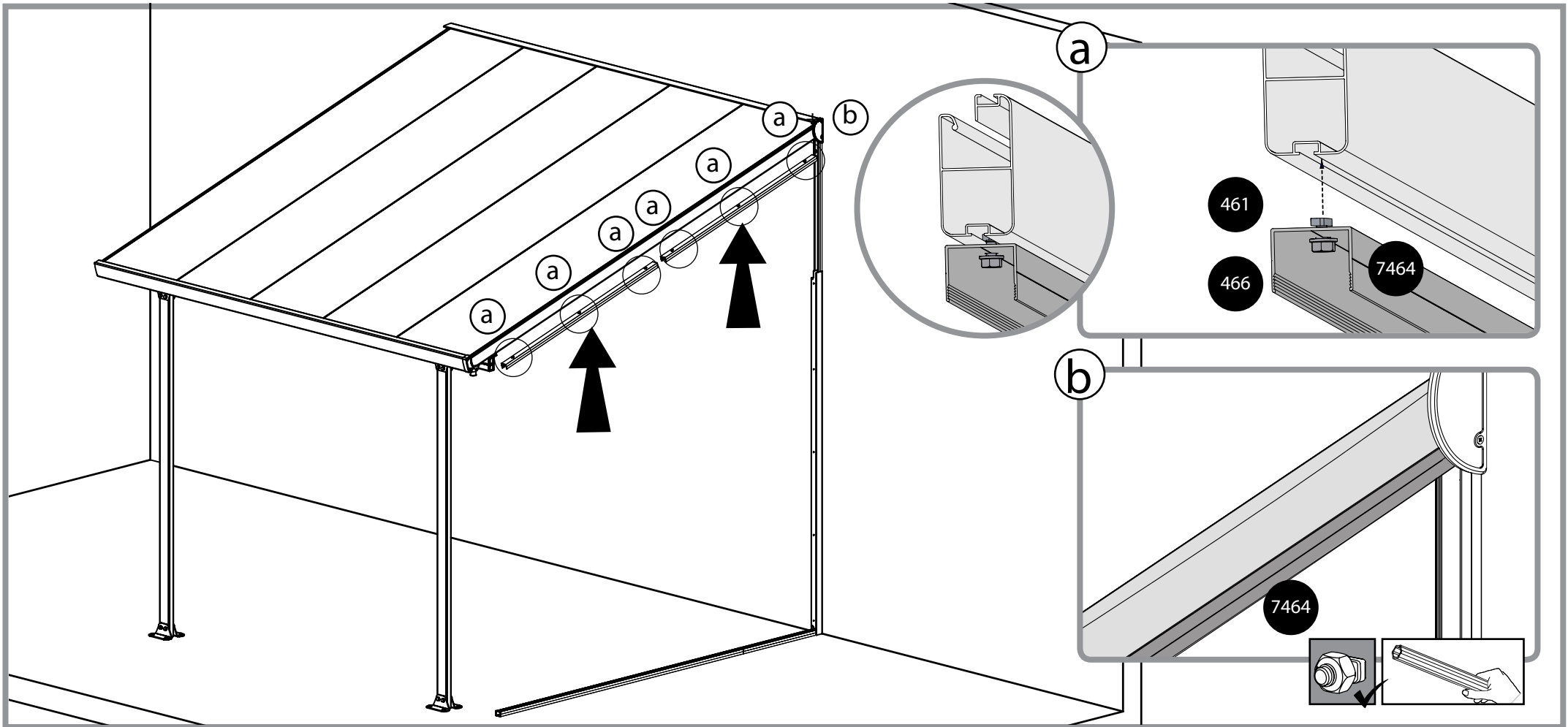

12

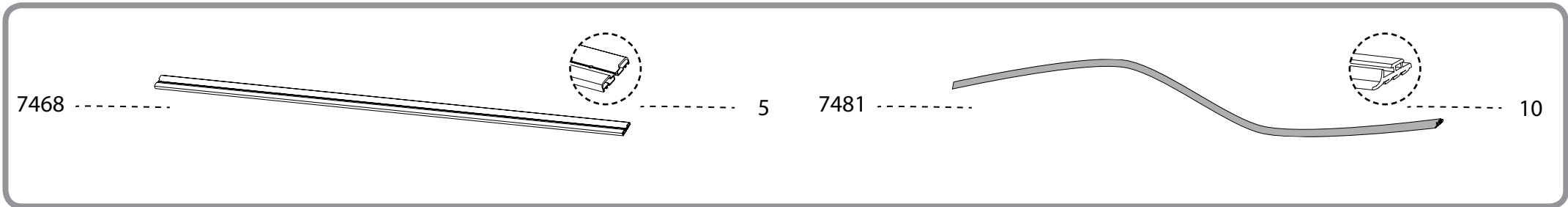

X5

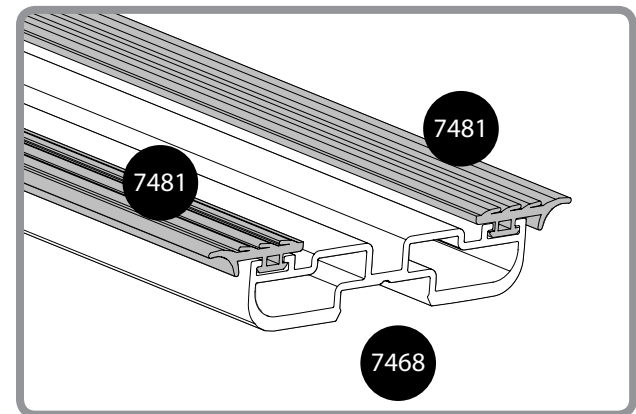
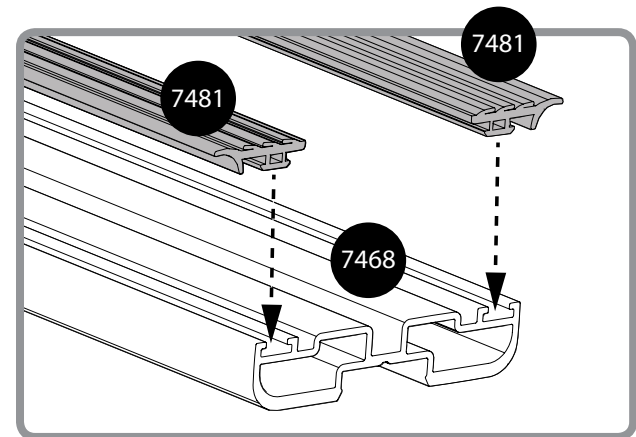

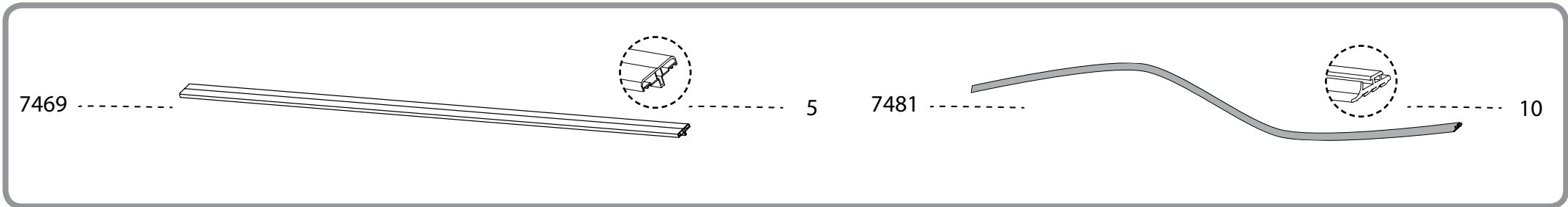

X5

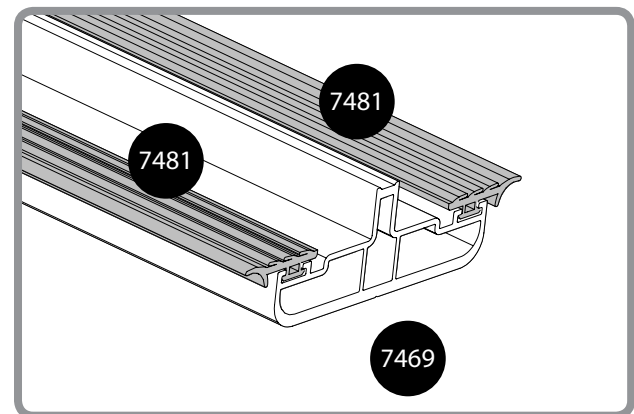
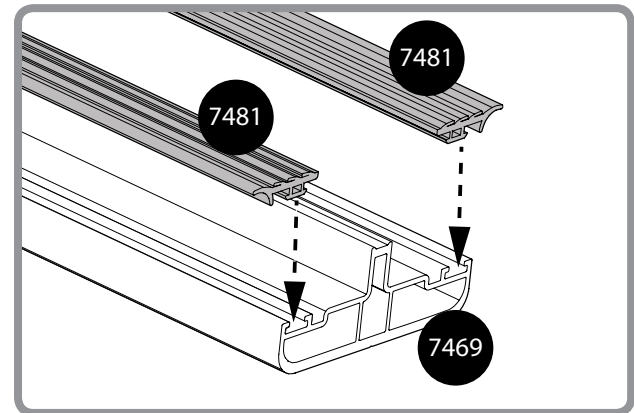
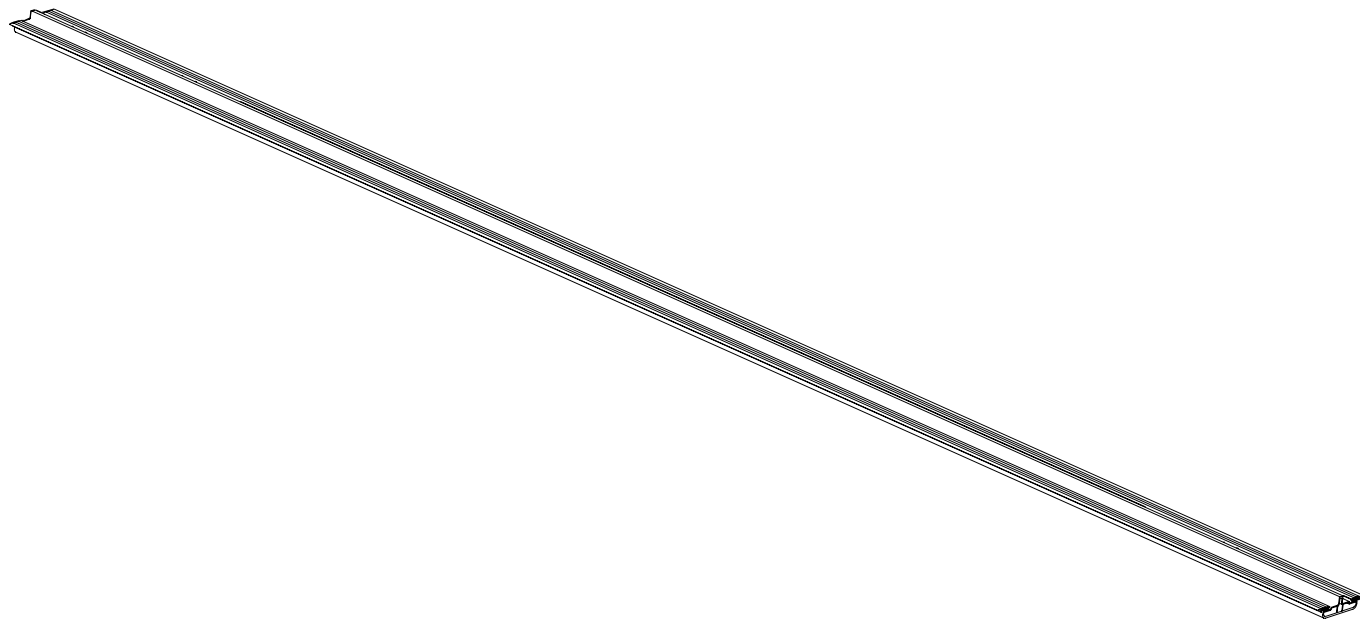

7471

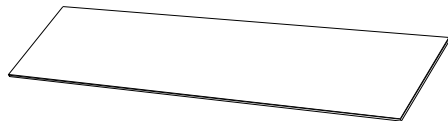

..... 4

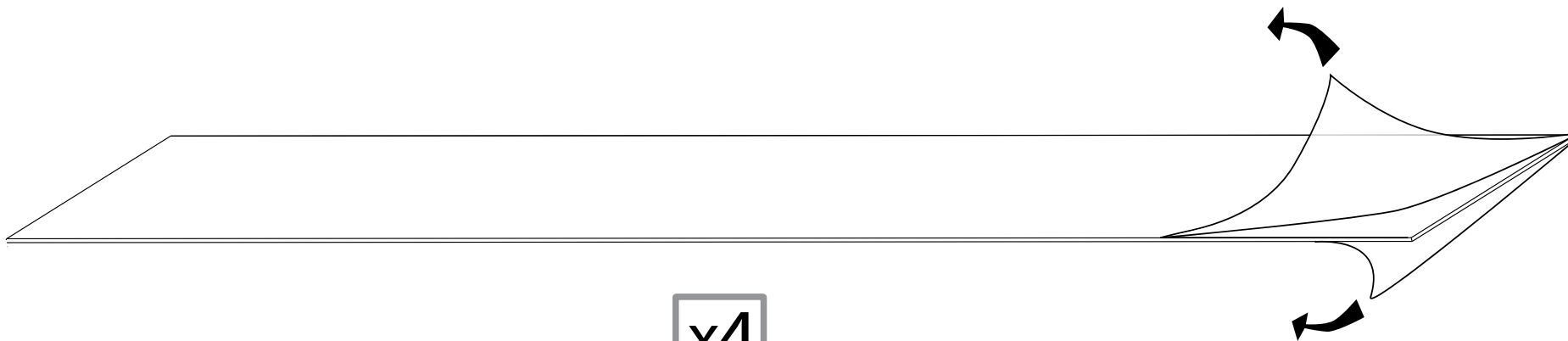

x4

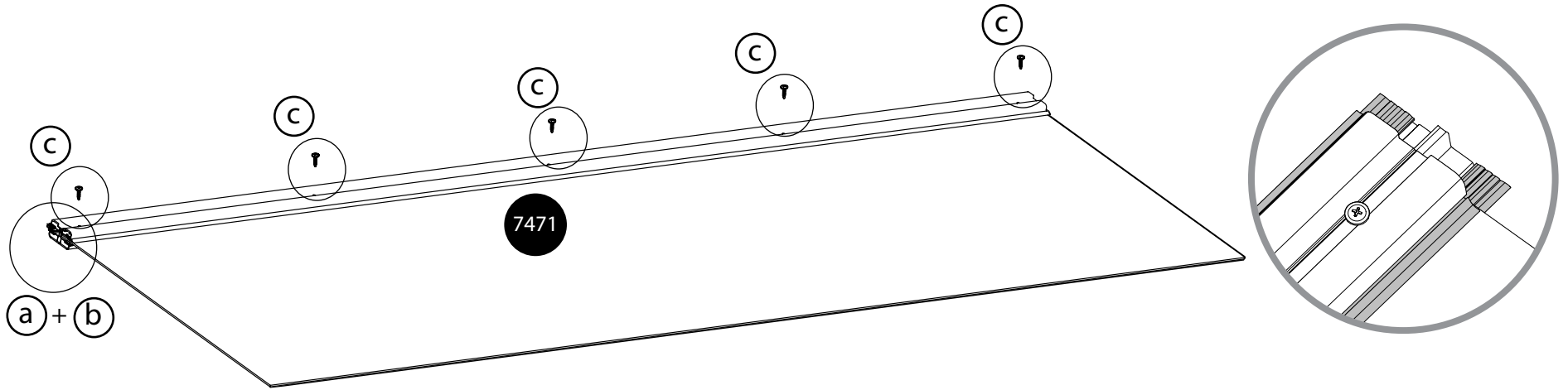
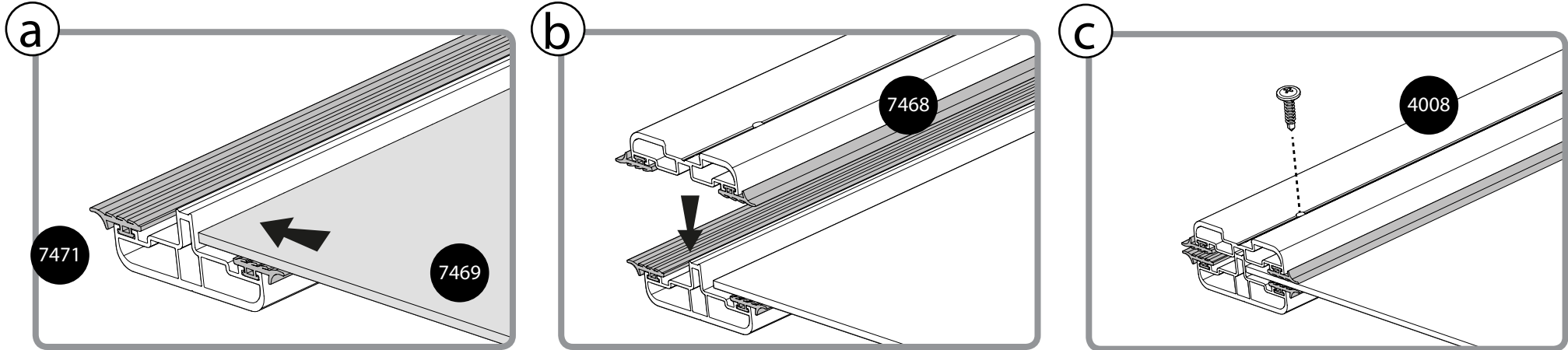
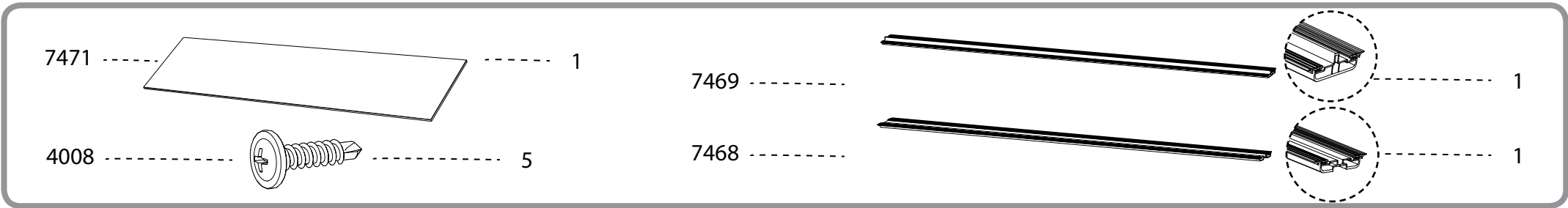

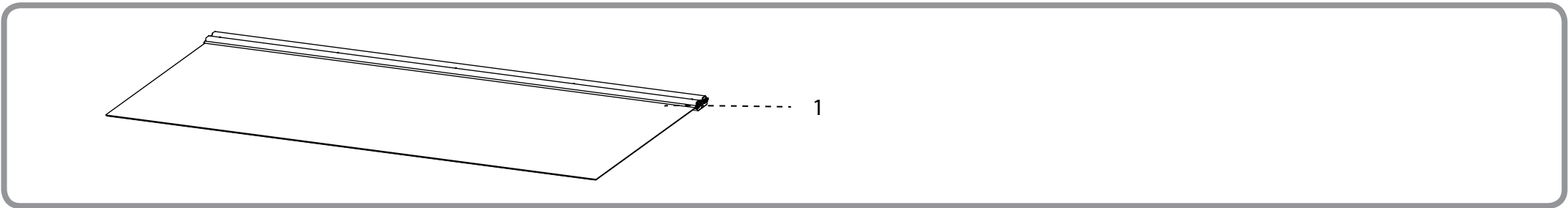

Option 1 EN-Left side | DE-Linke Seite | FR-côté gauche

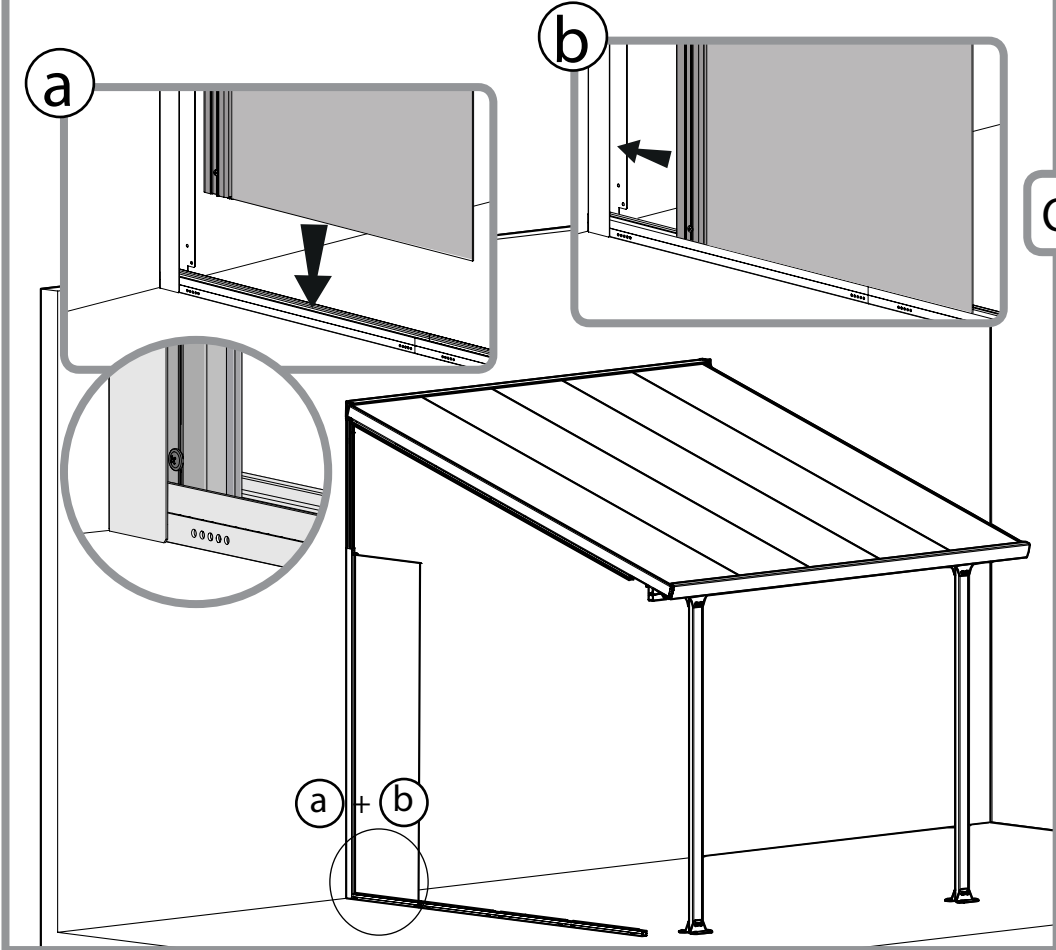

OR

Option 2 EN-Right side | DE-echte Seite | FR-côté droit

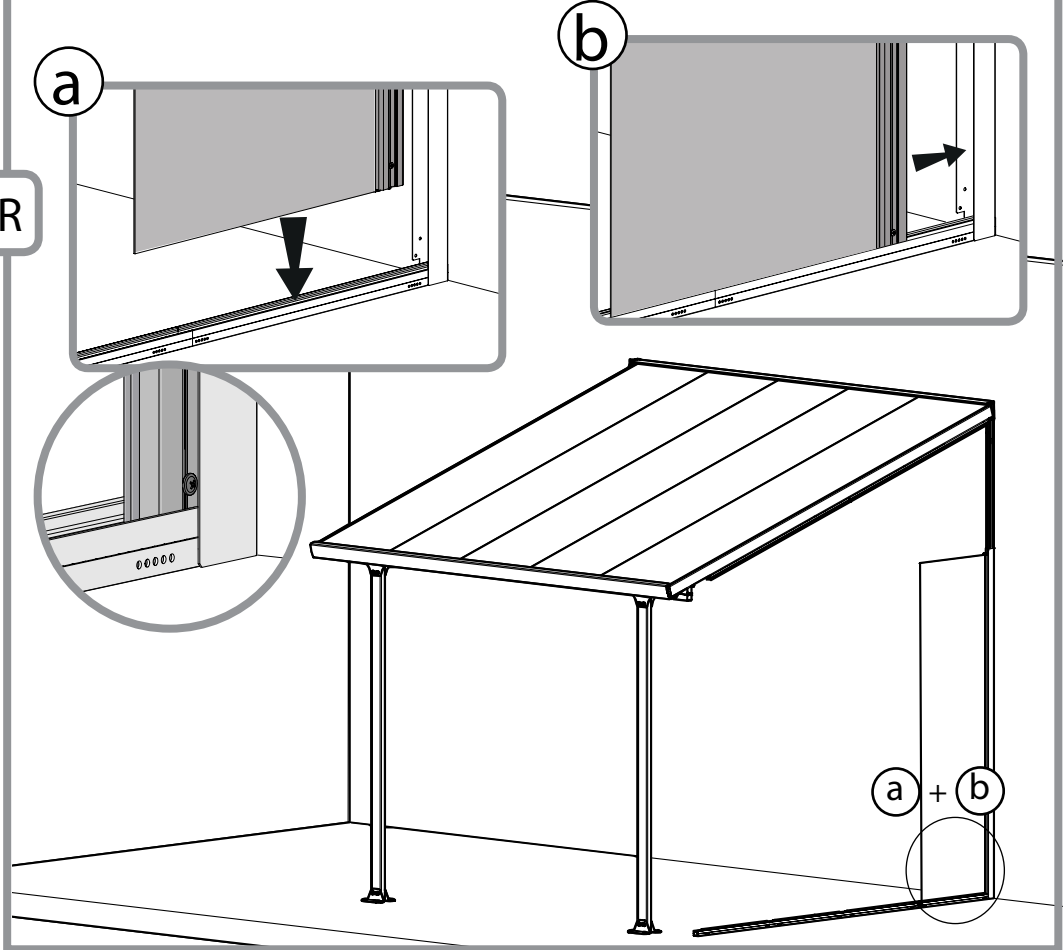

4008 4

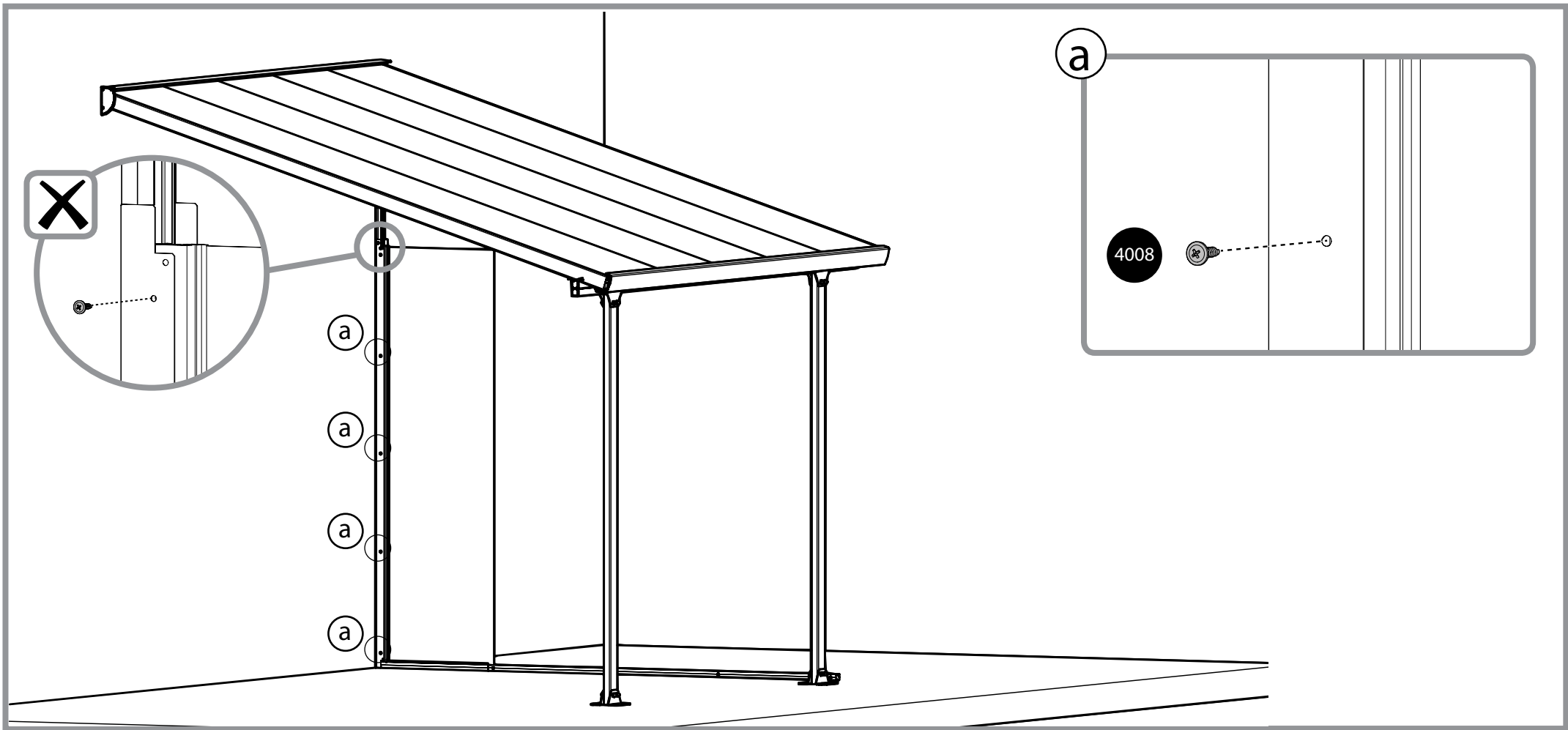
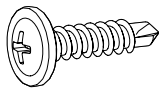

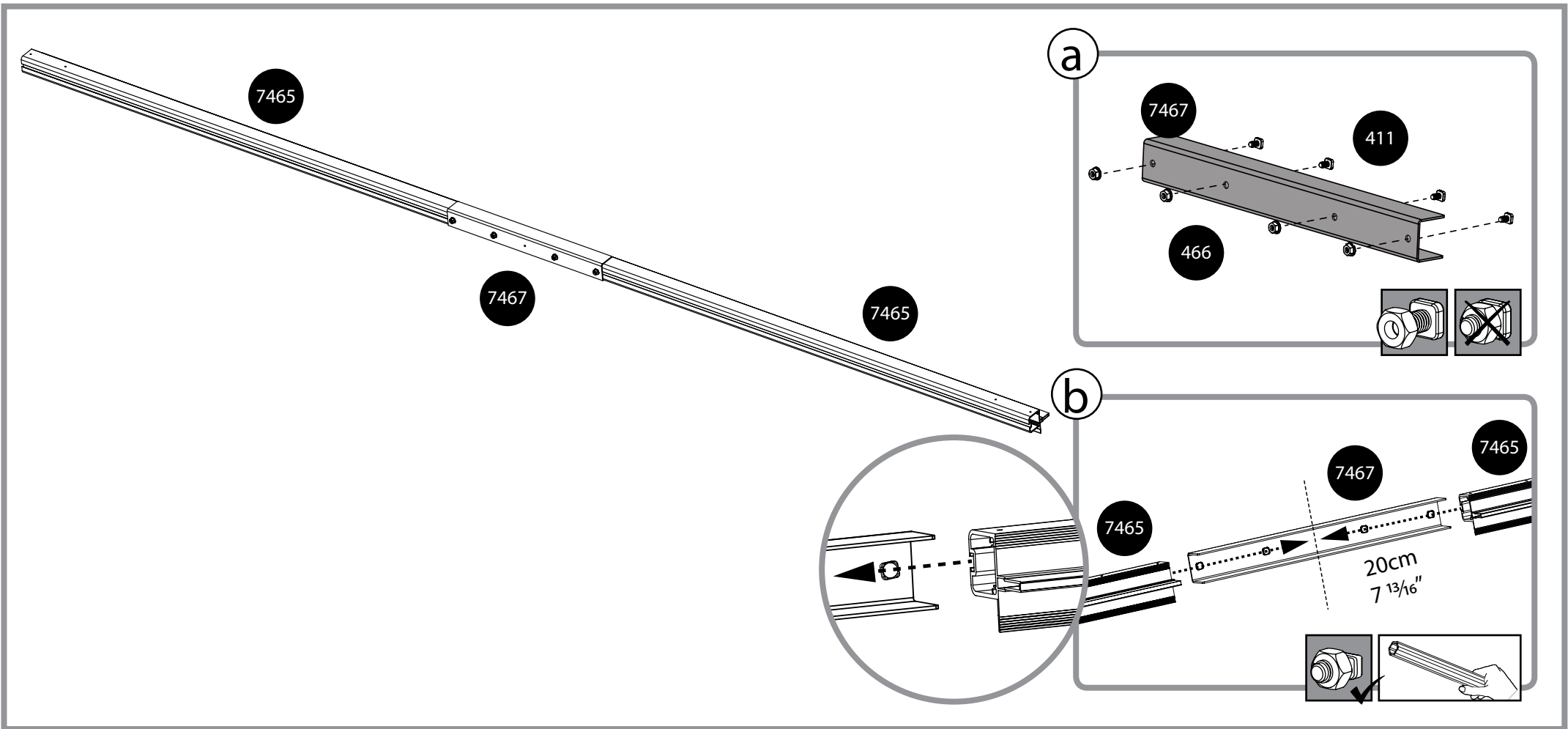
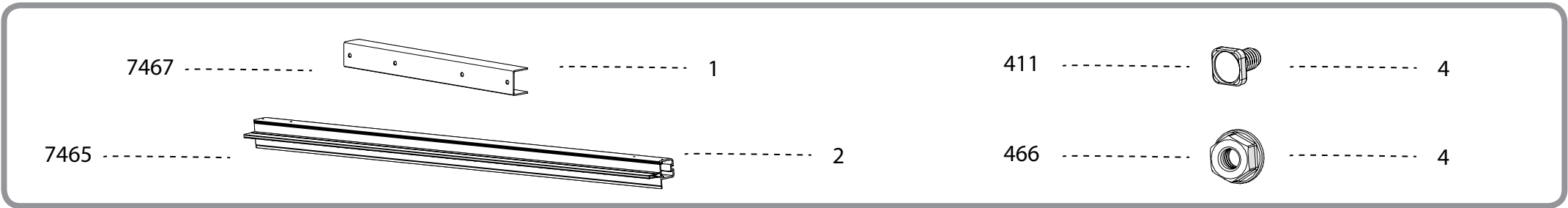

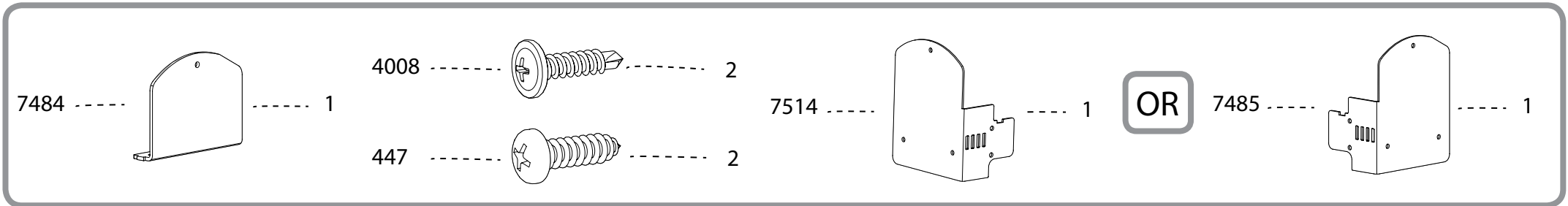

Option 1 EN-Left side | DE-Linke Seite | FR-côté gauche

Option 2 EN-Right side | DE-echte Seite | FR-côté droit

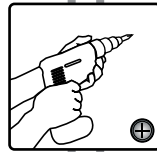

OR

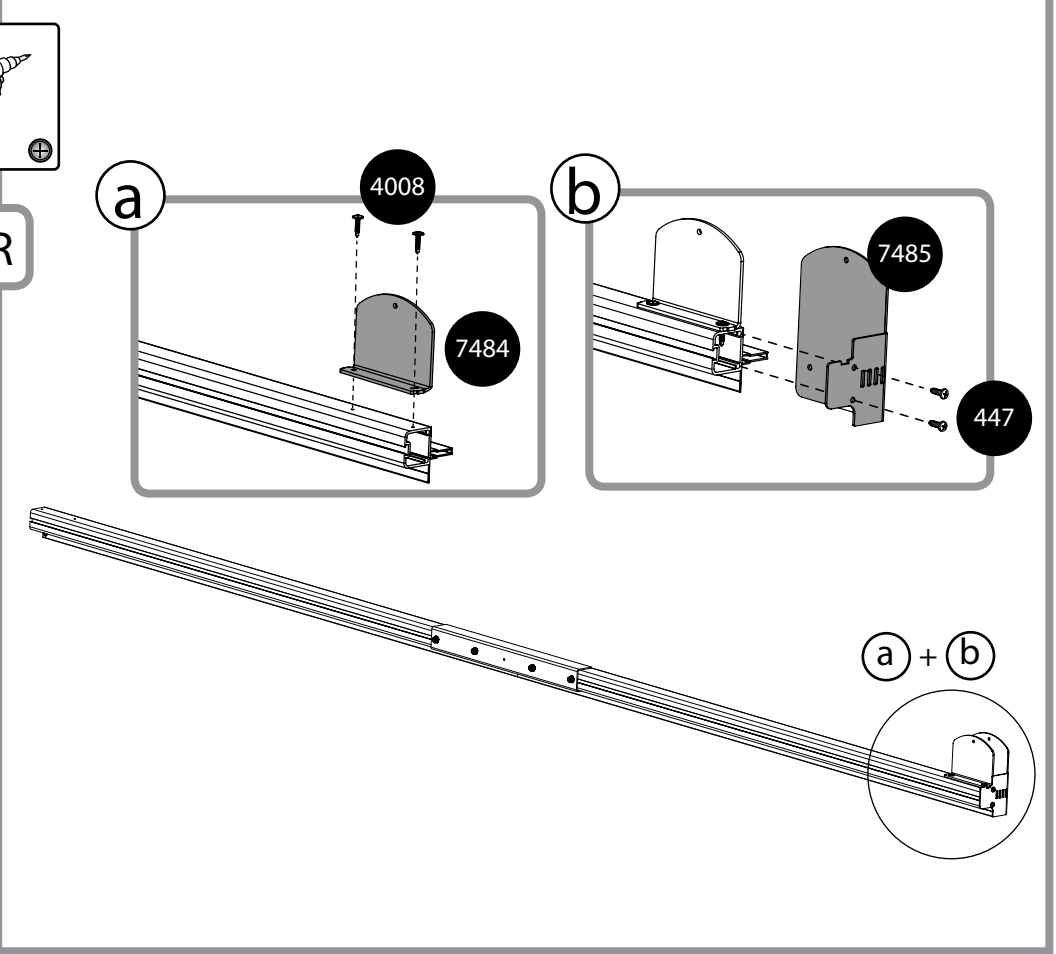
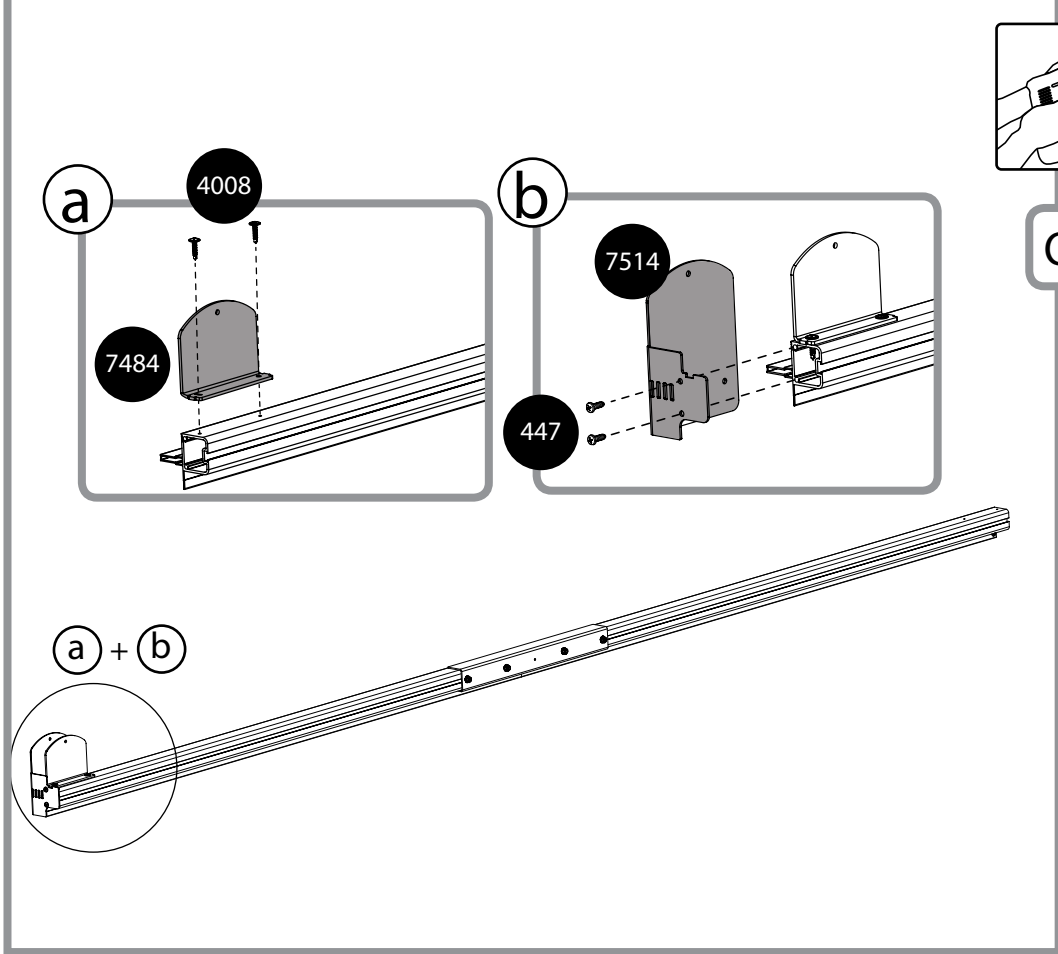

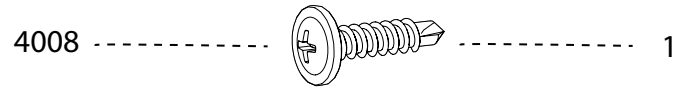

Option 1 EN-Left side | DE-Linke Seite | FR-côté gauche

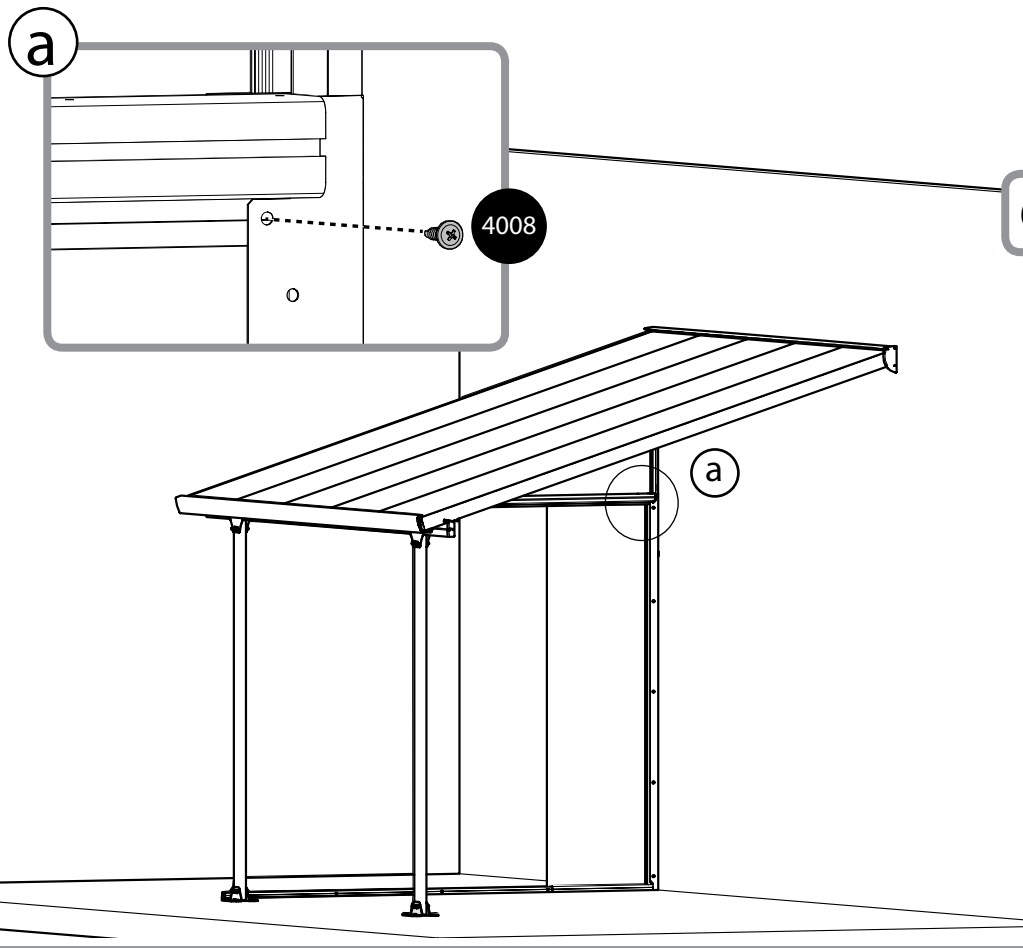

OR

Option 2 EN-Right side | DE-echte Seite | FR-côté droit

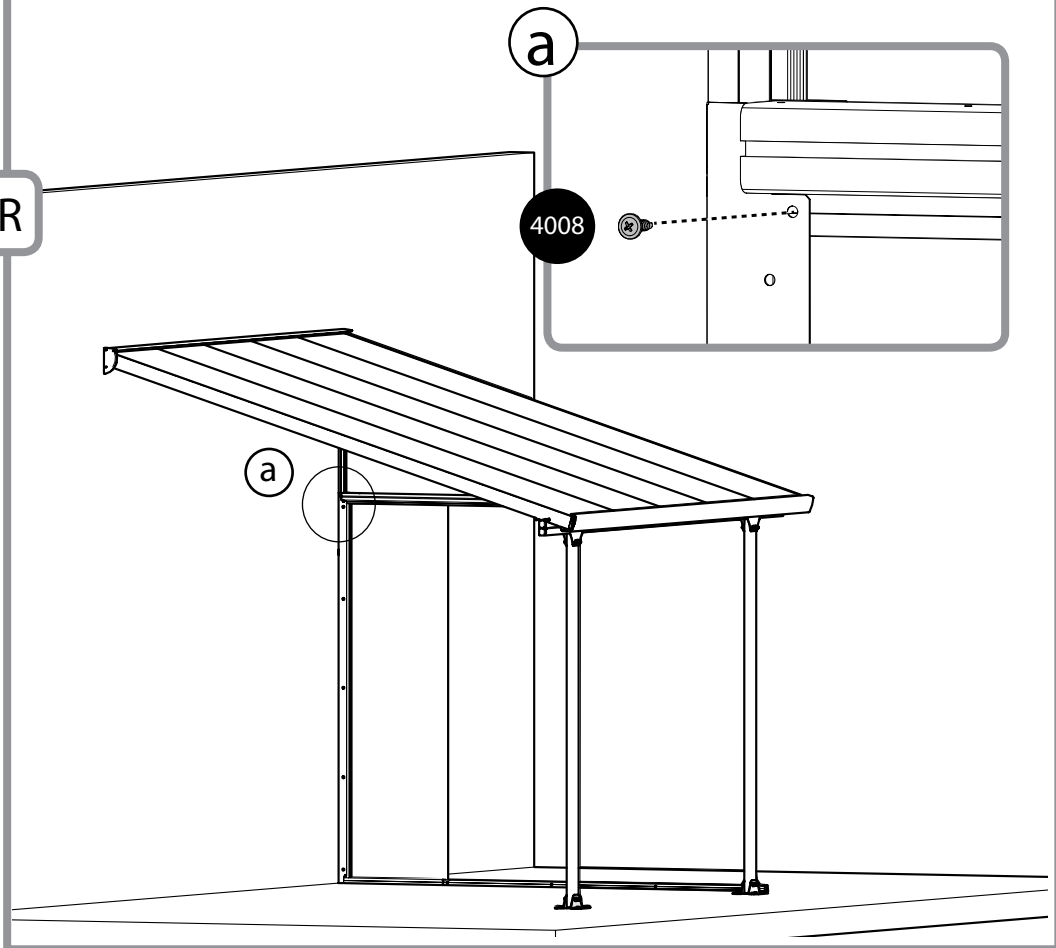

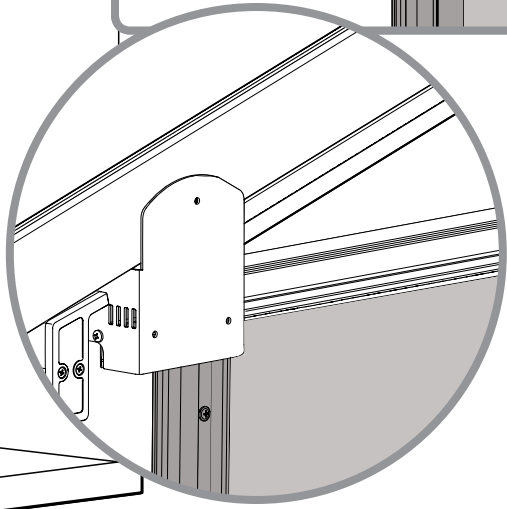
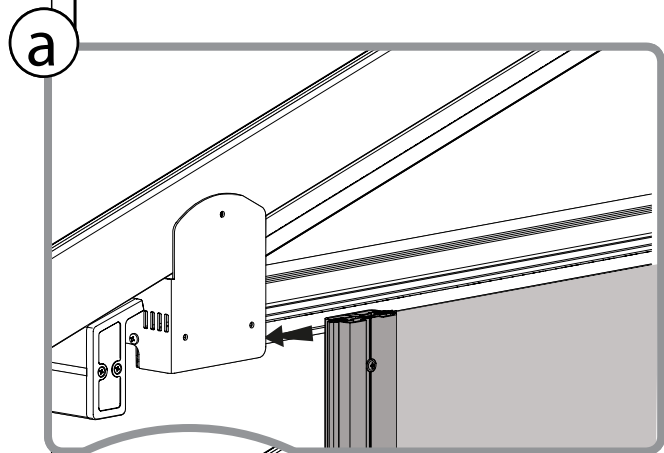
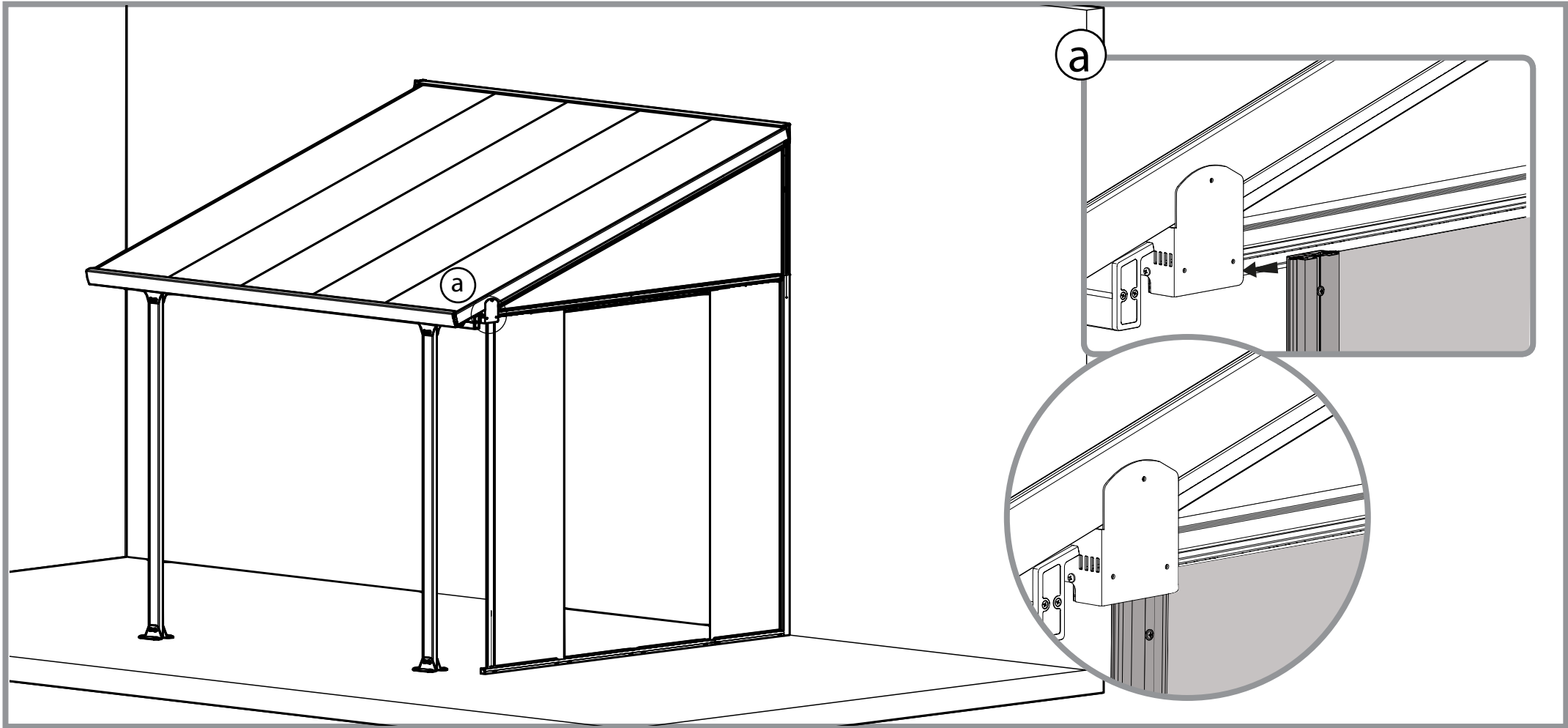
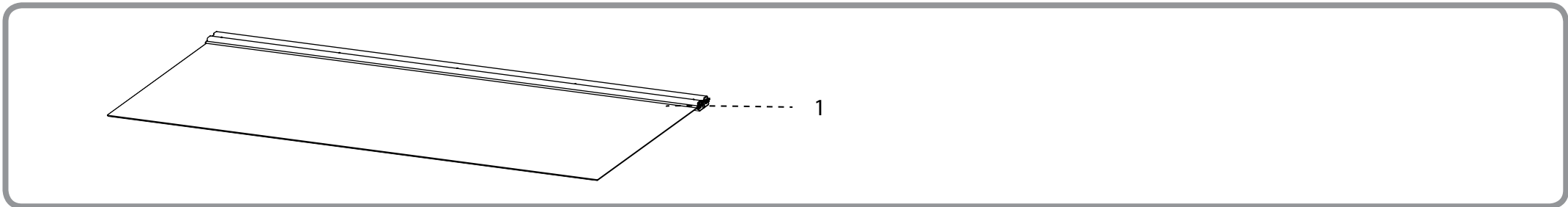

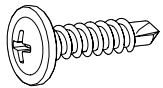
4008  2

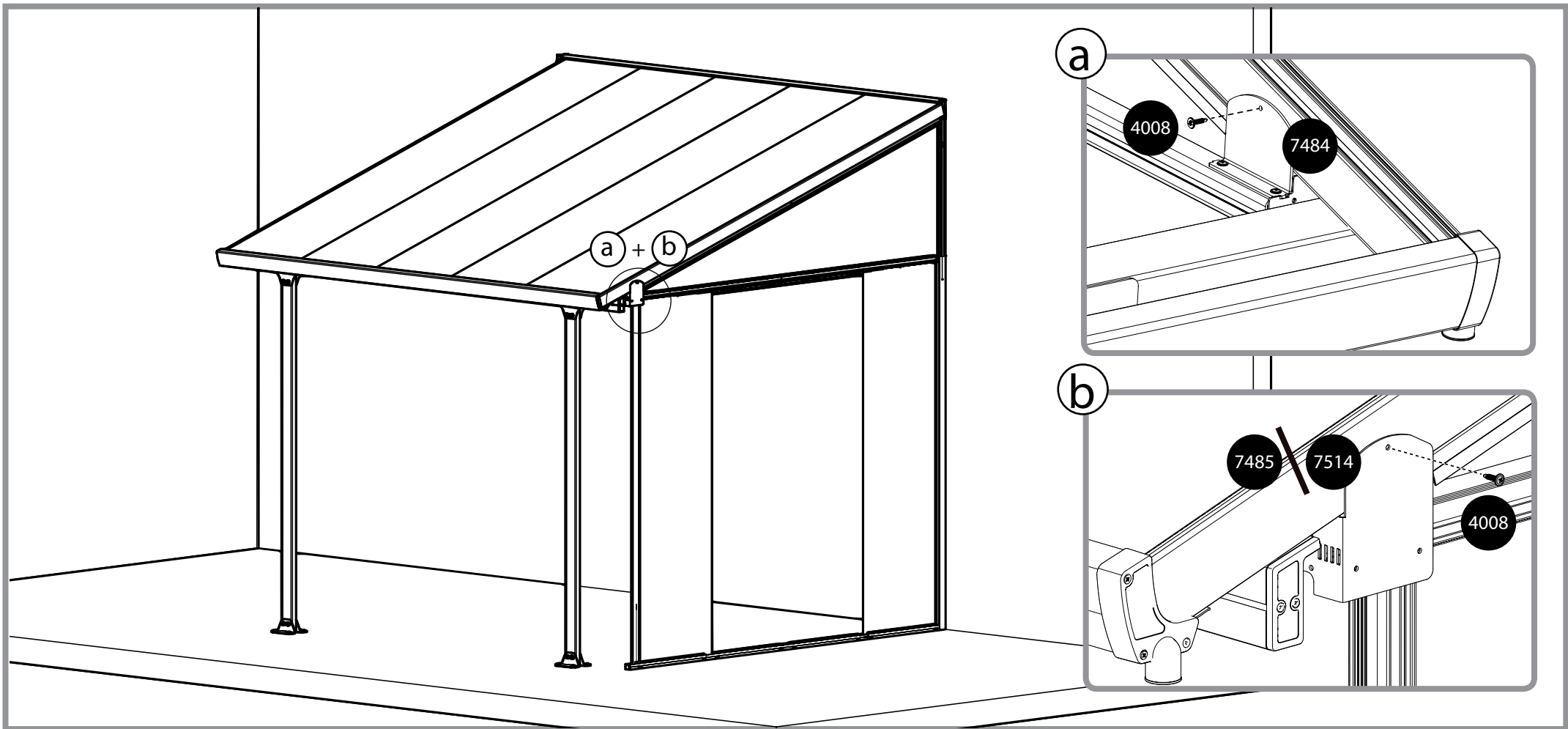

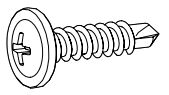
4008  2

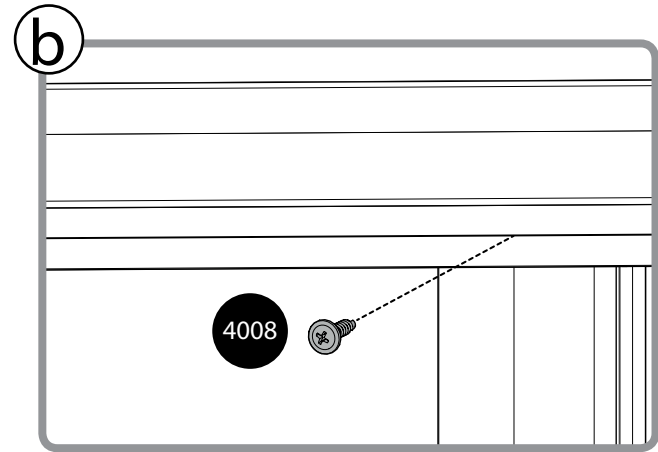
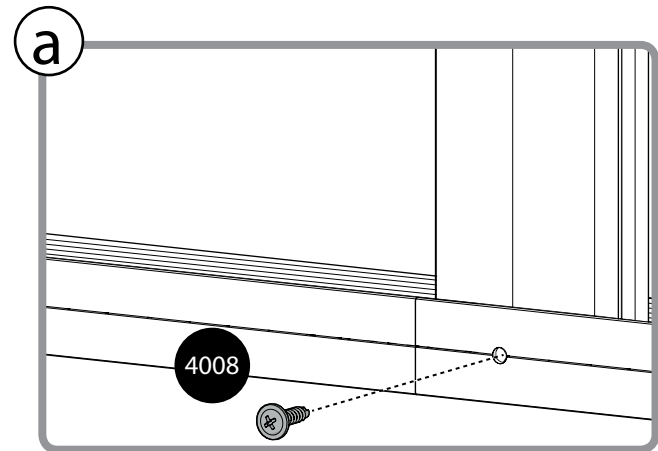
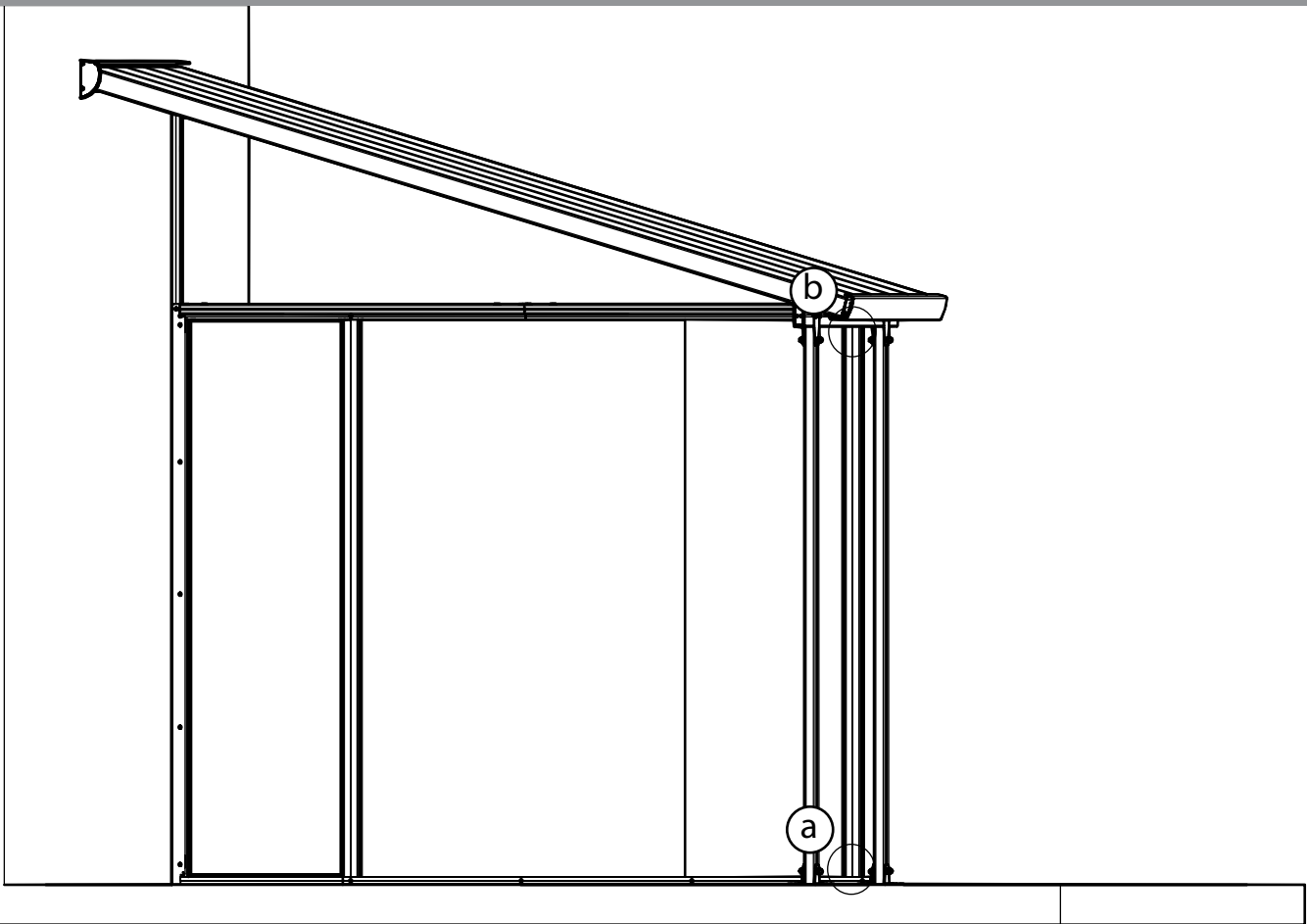

7469

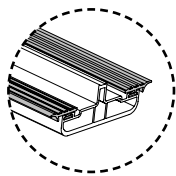

1

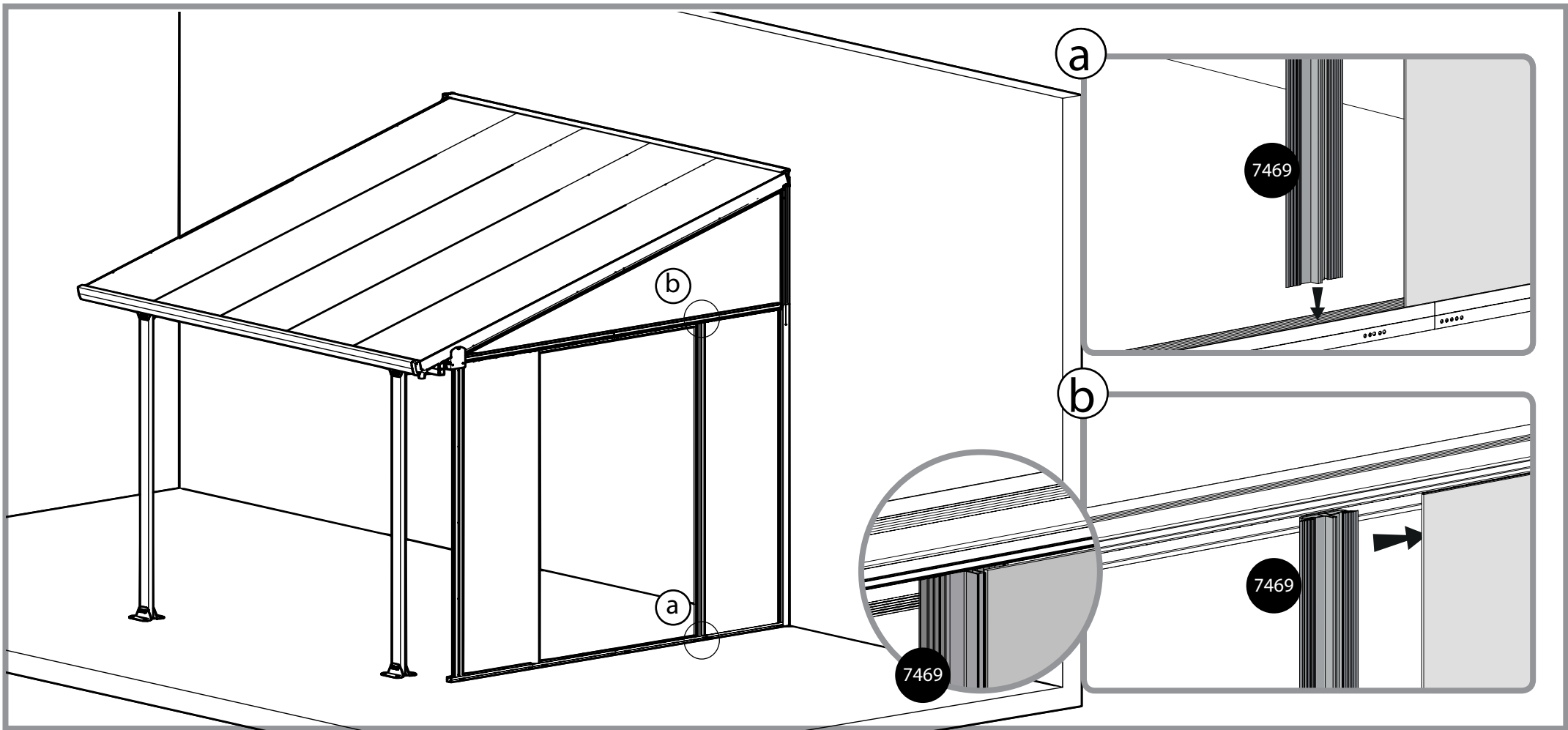

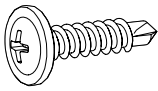
4008  2

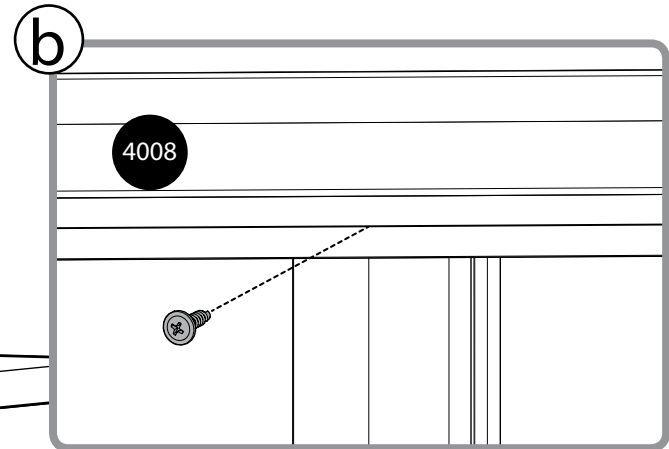
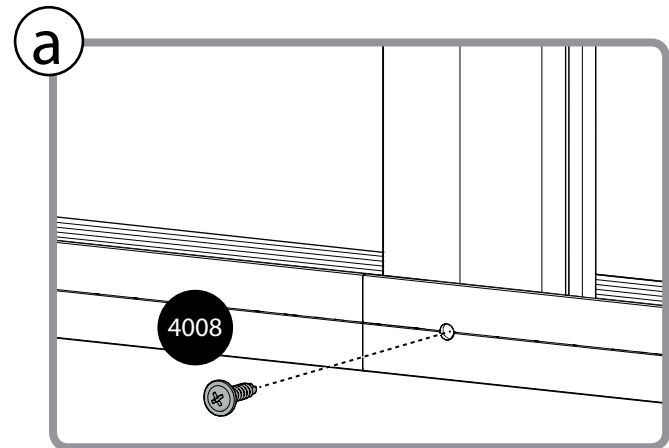
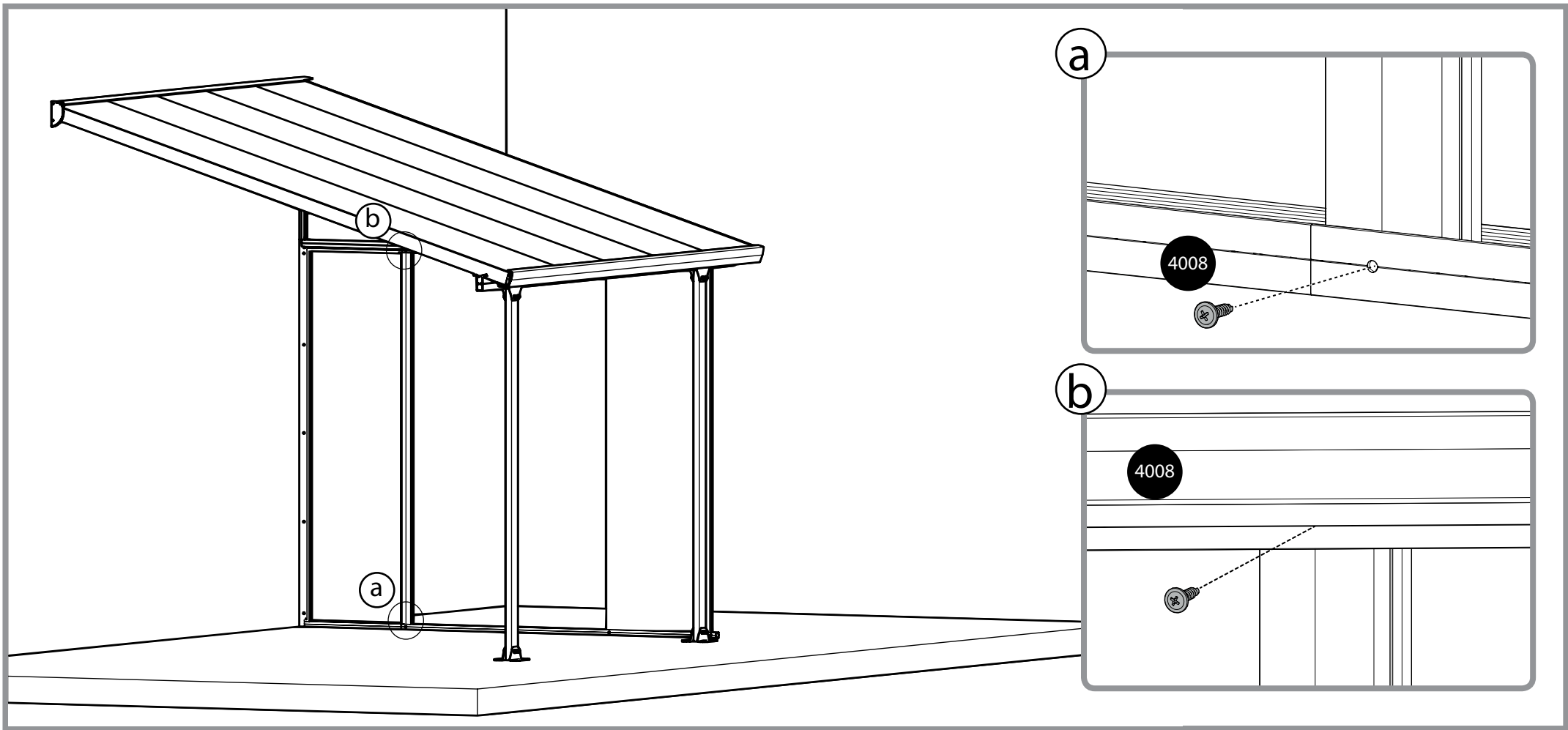

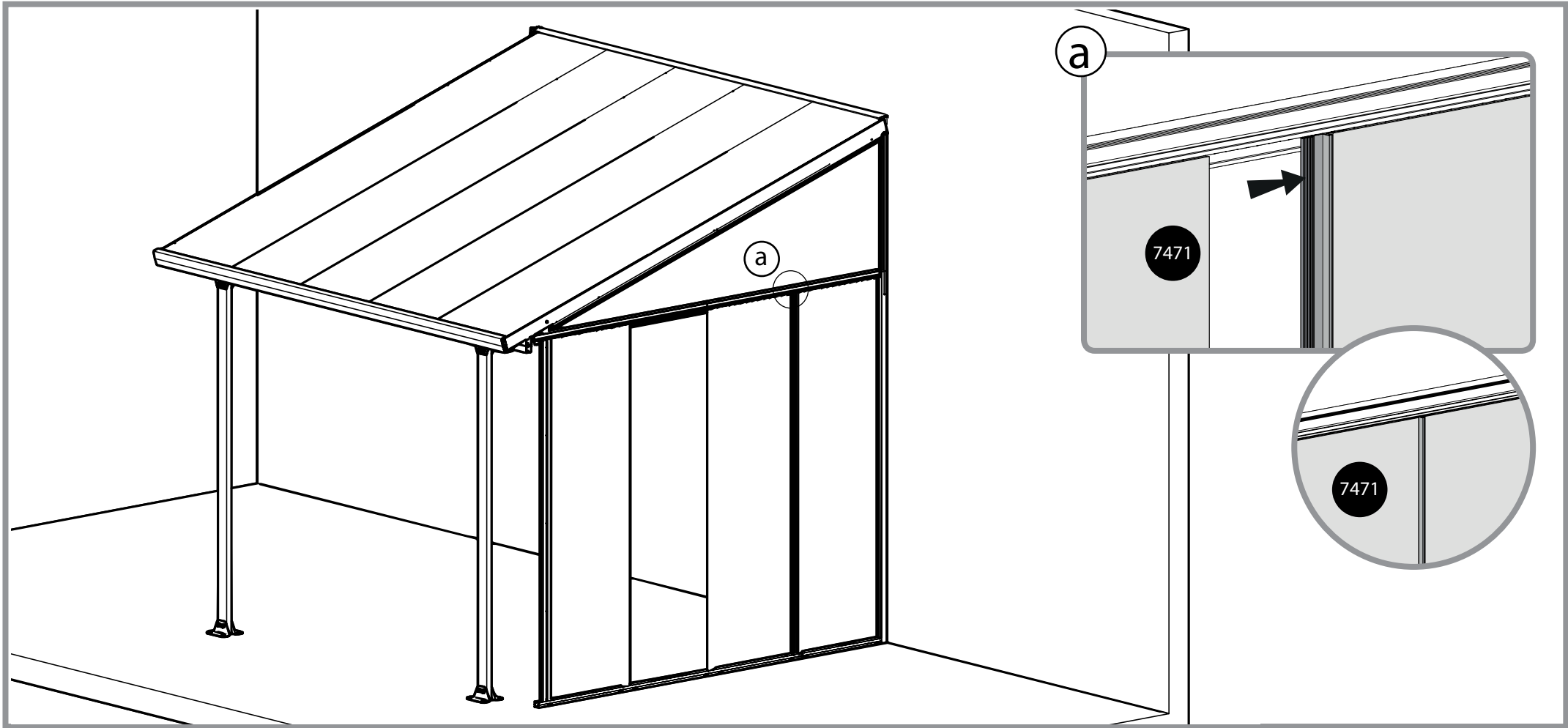
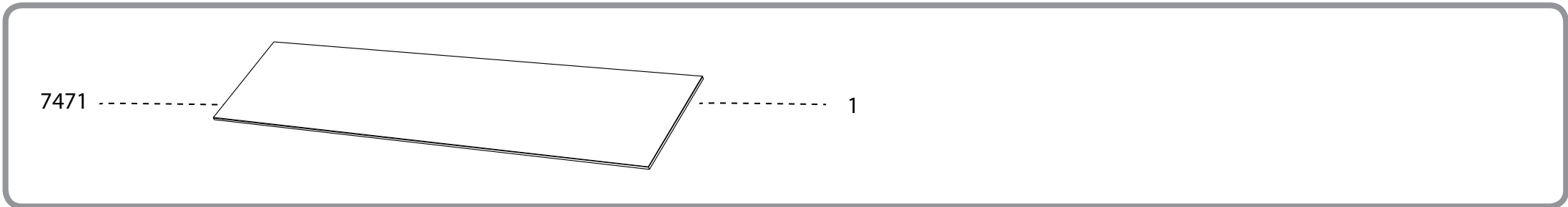

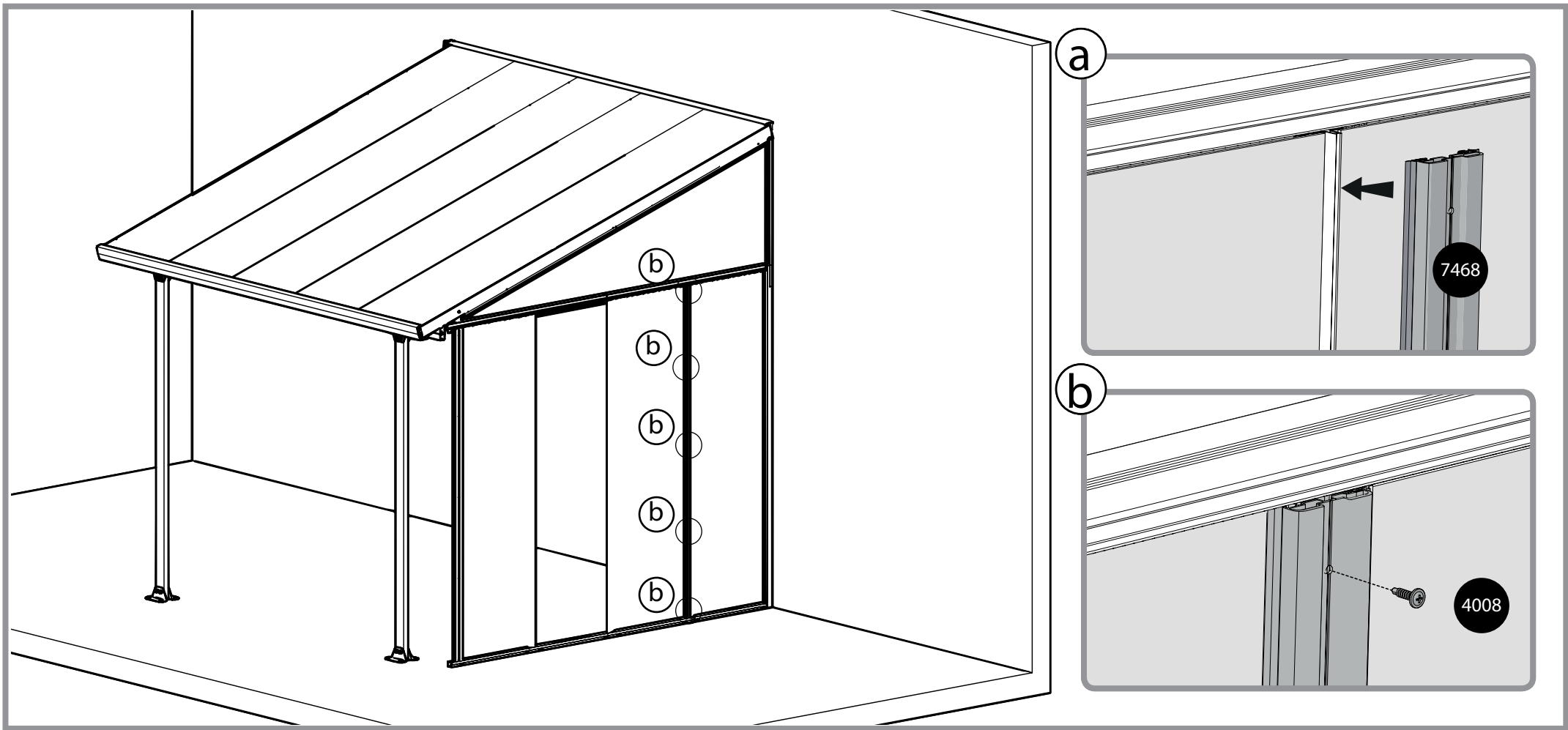
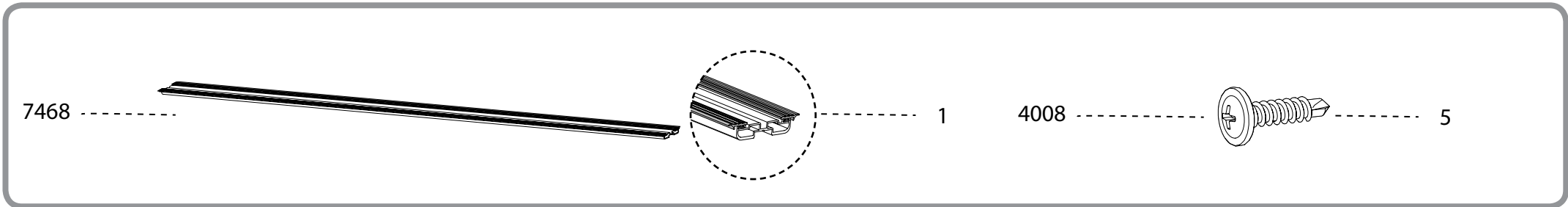

7469

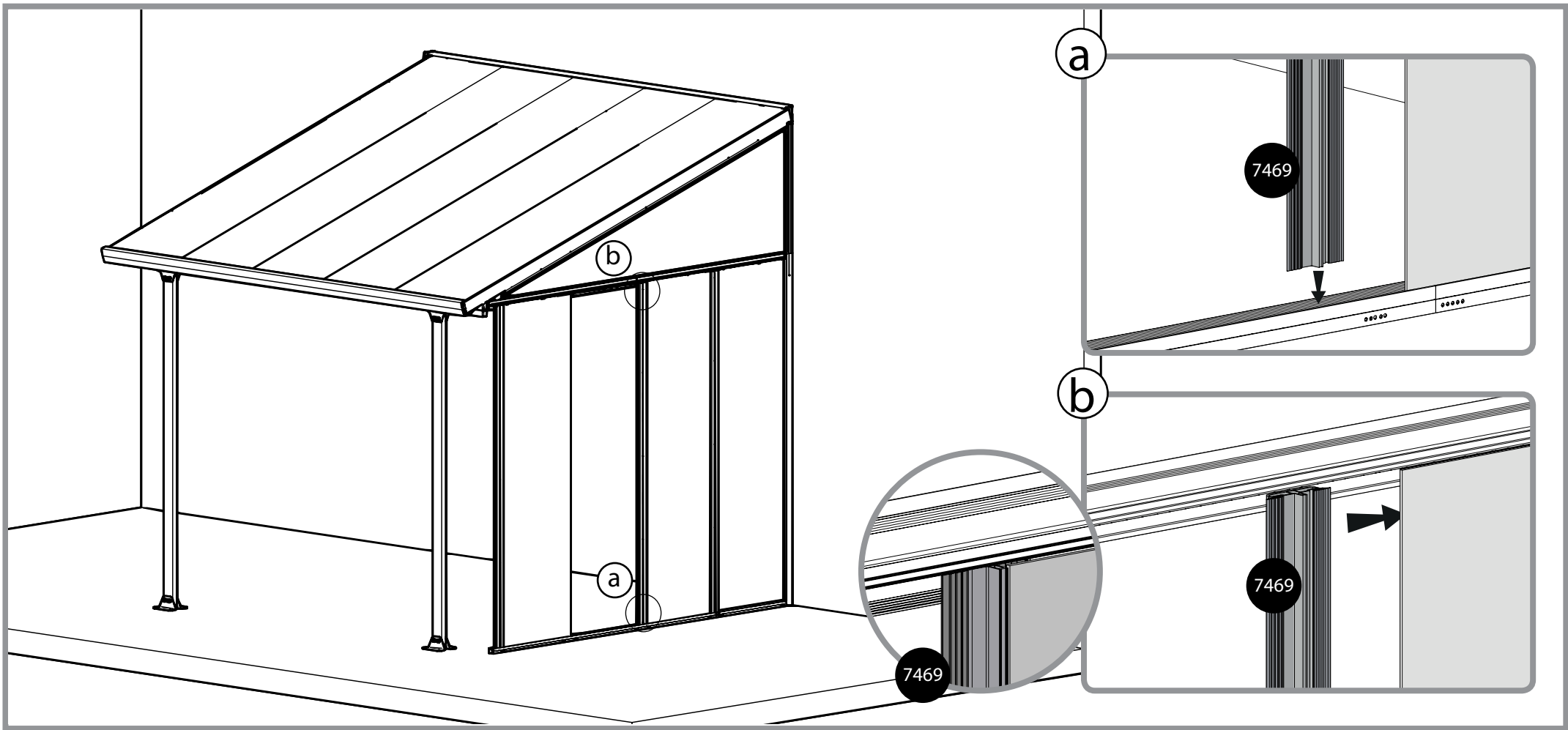
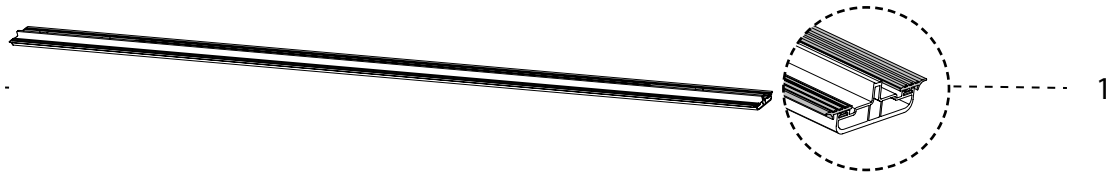

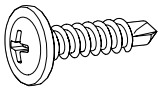
4008  2

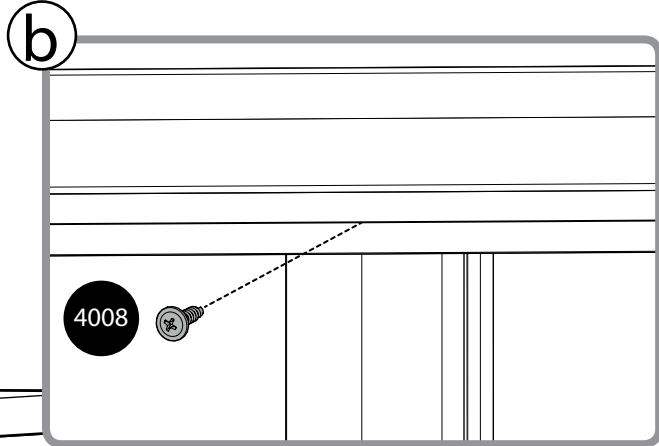
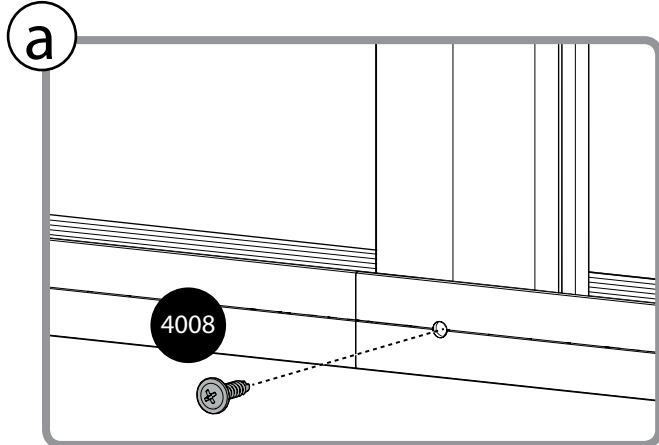
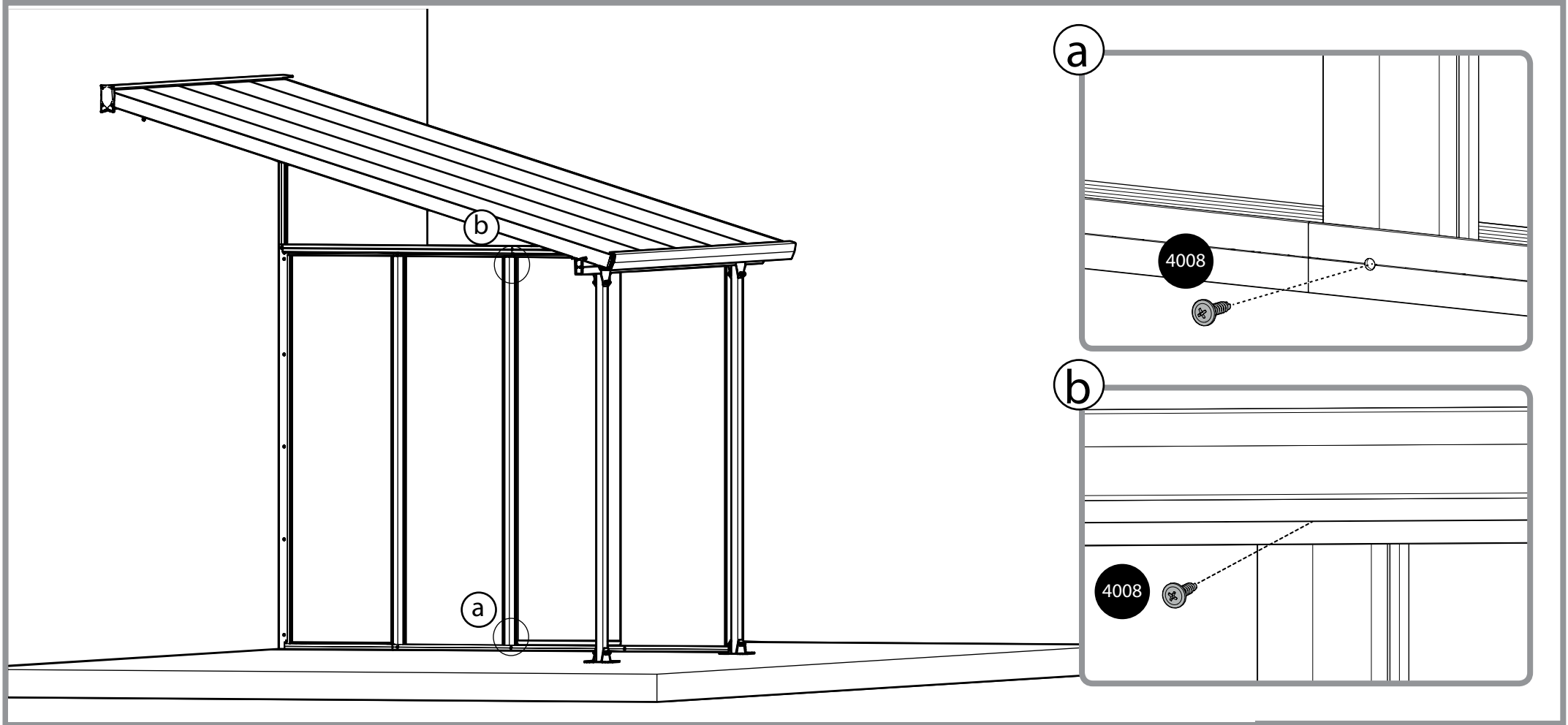

7469

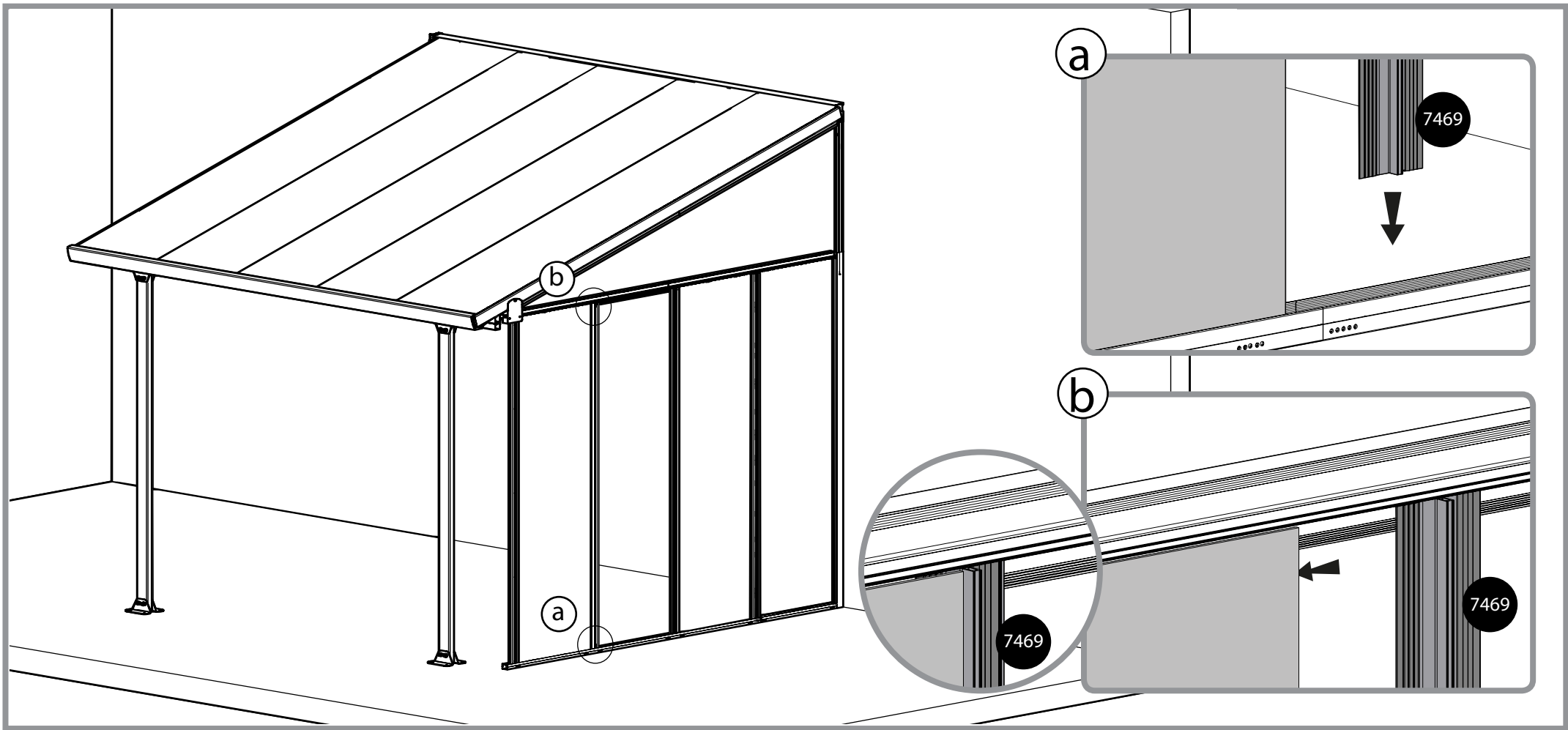
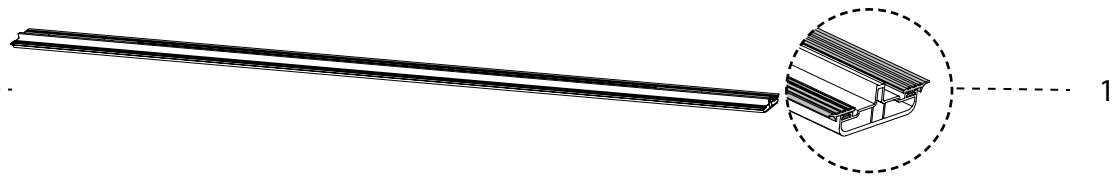

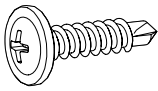
4008  2

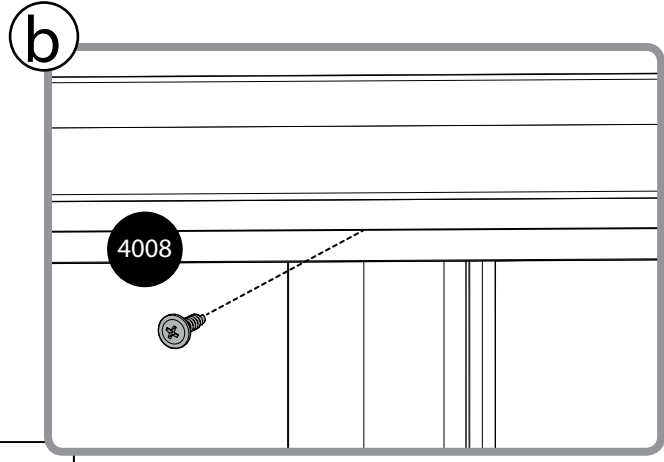
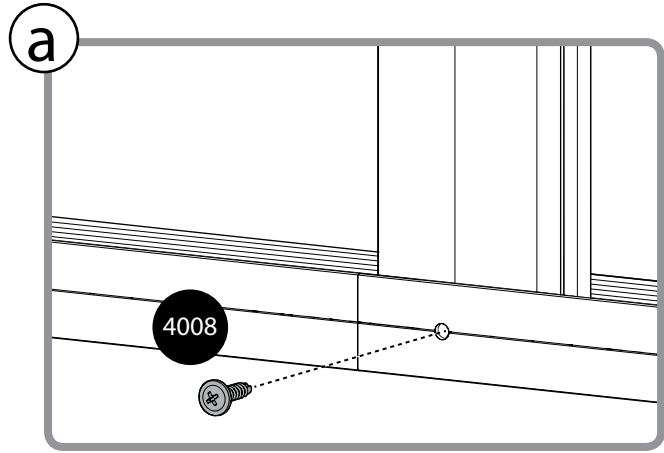
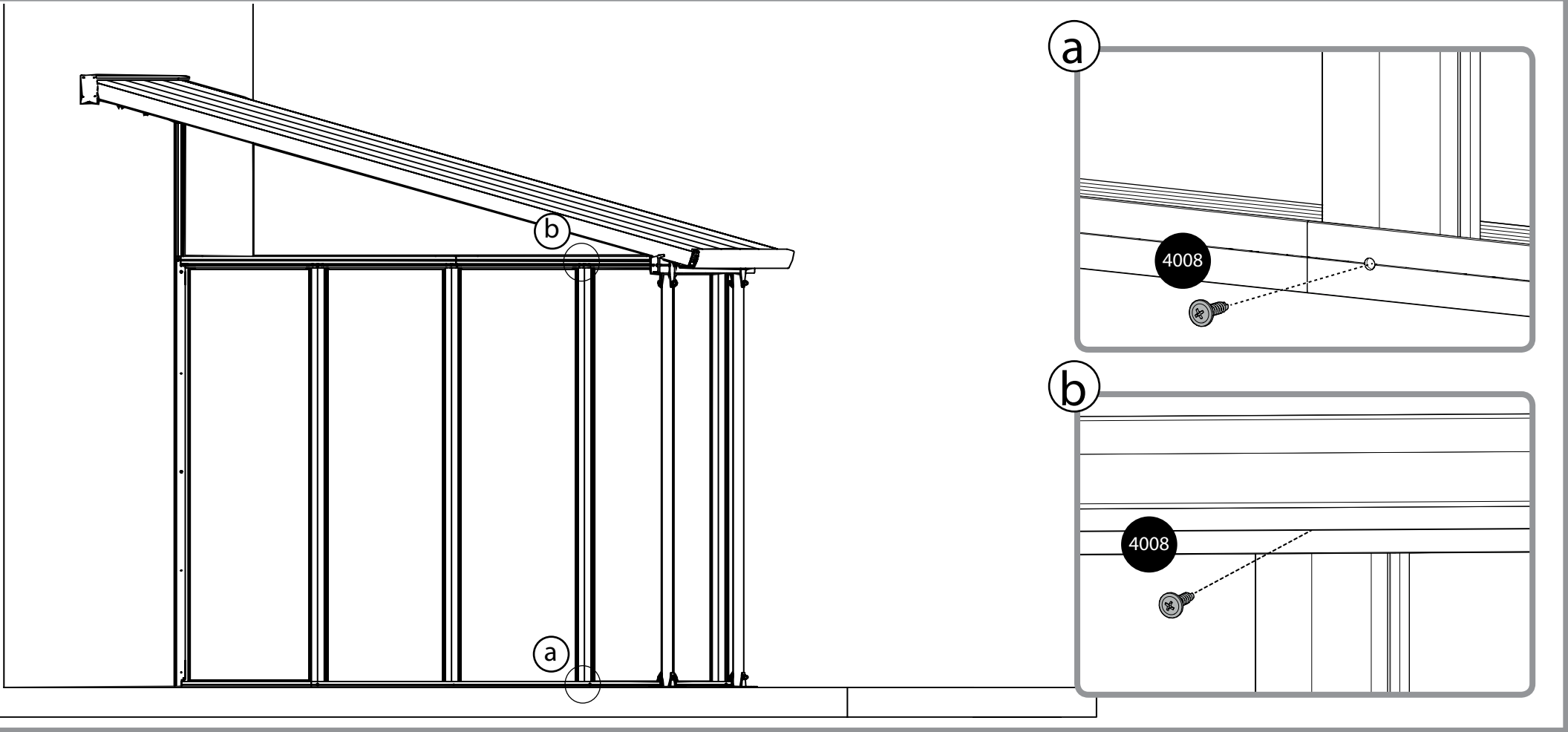

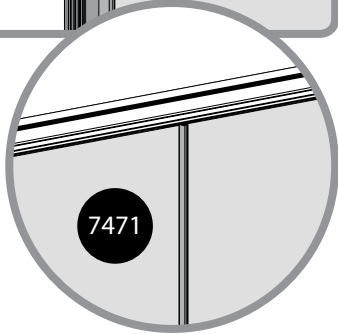
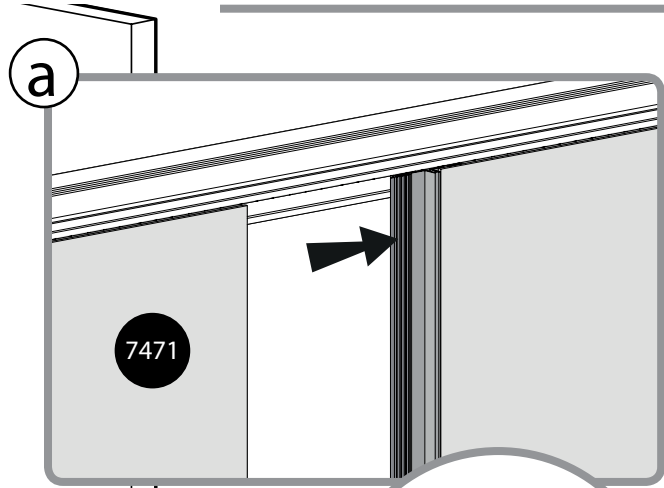
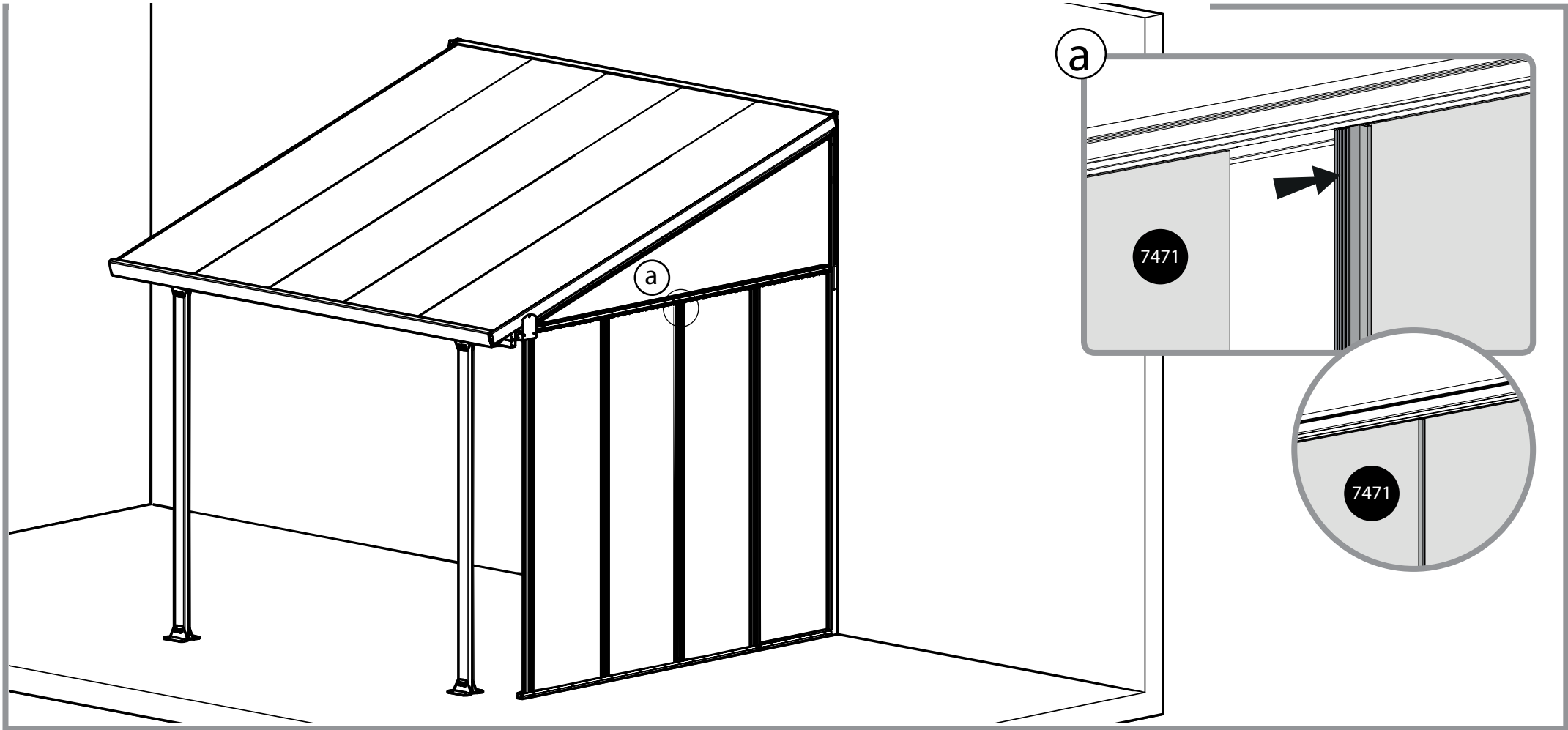
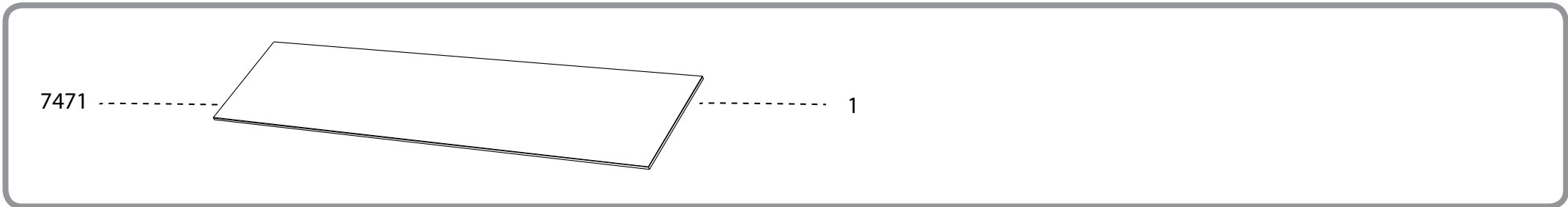

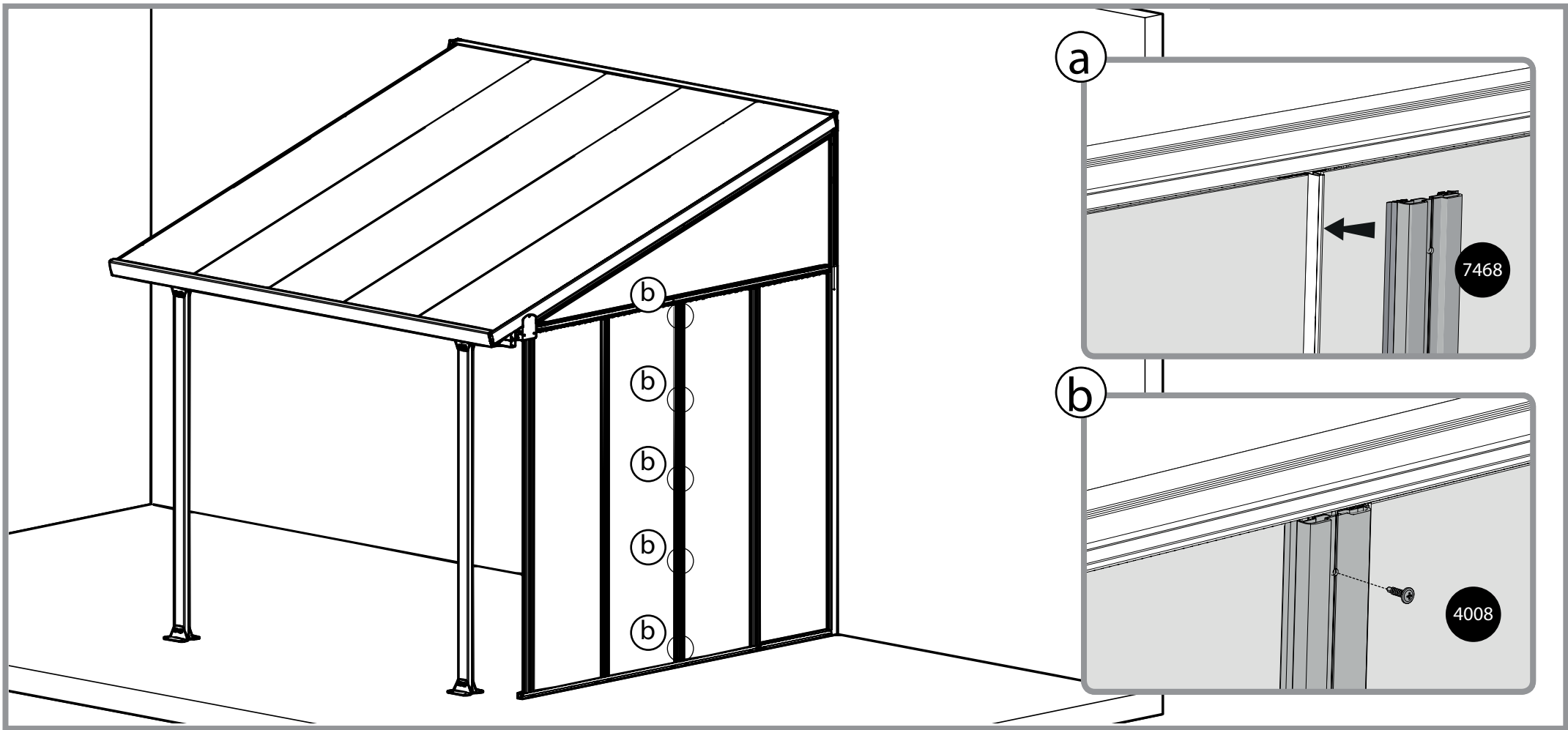
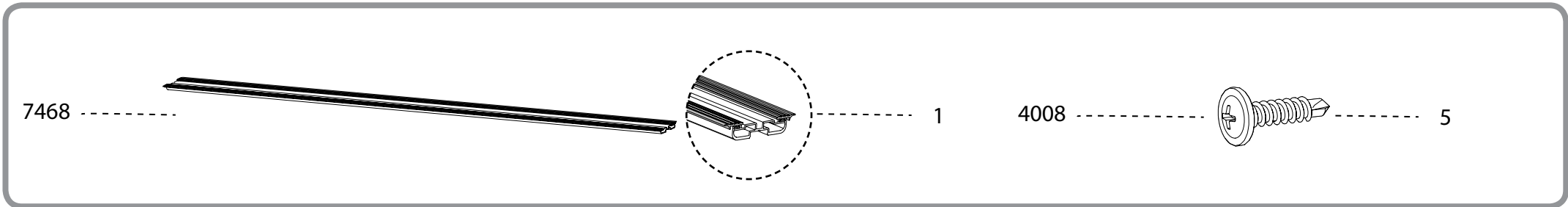

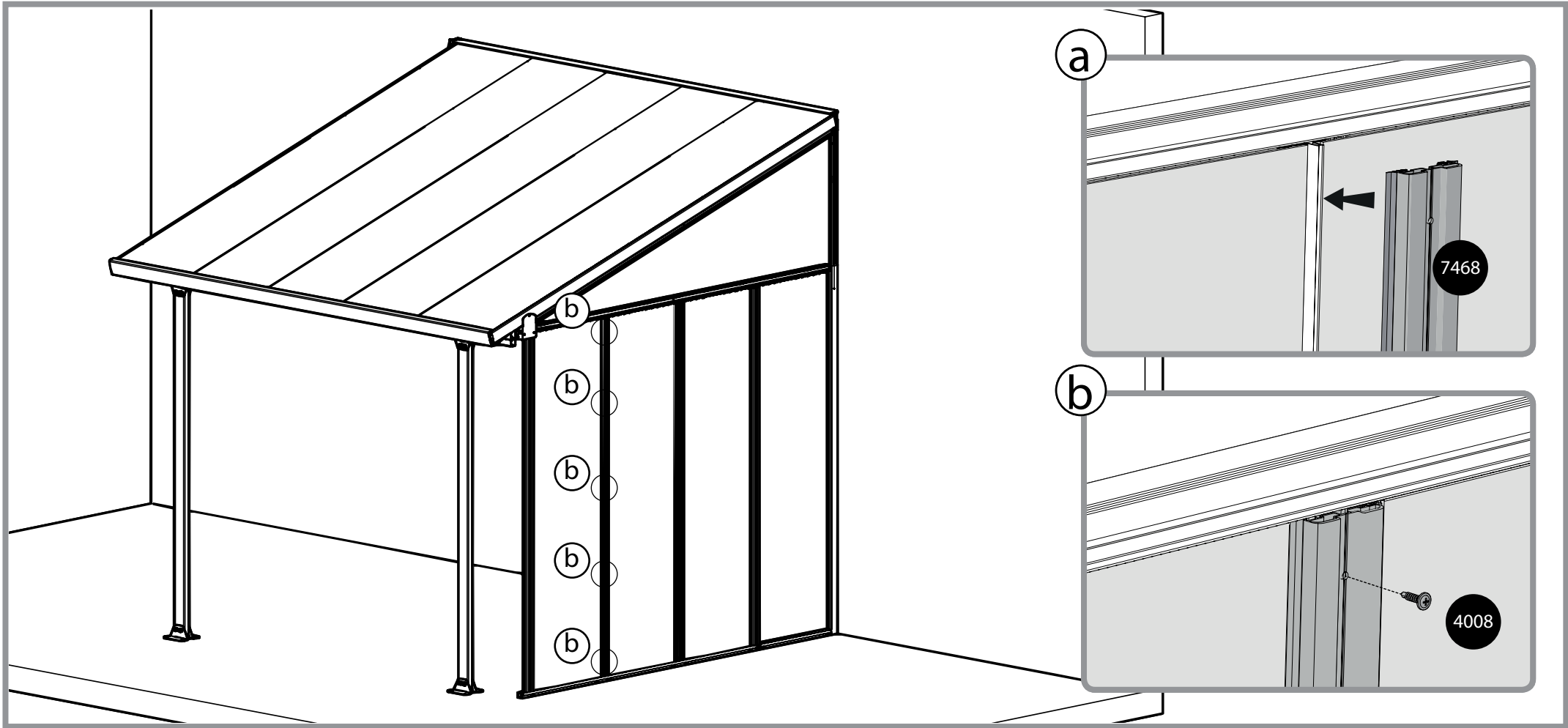
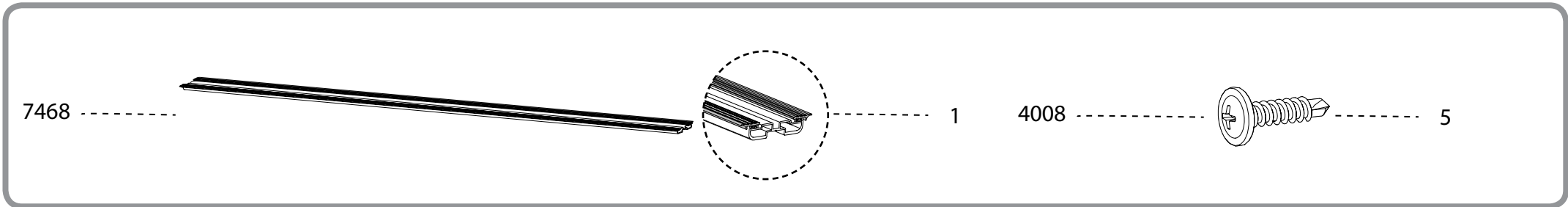

7470 4

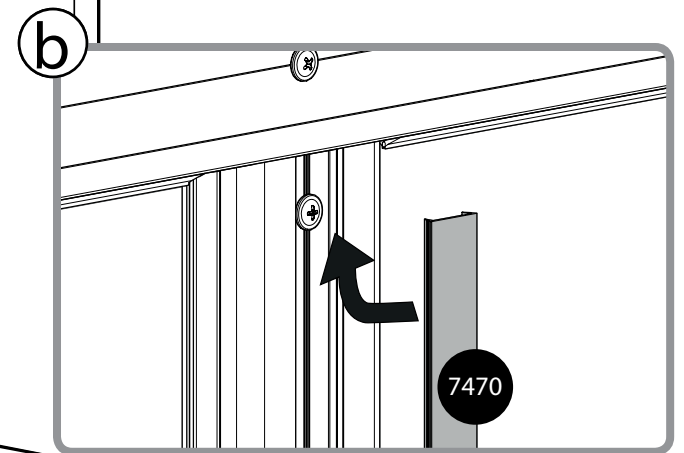
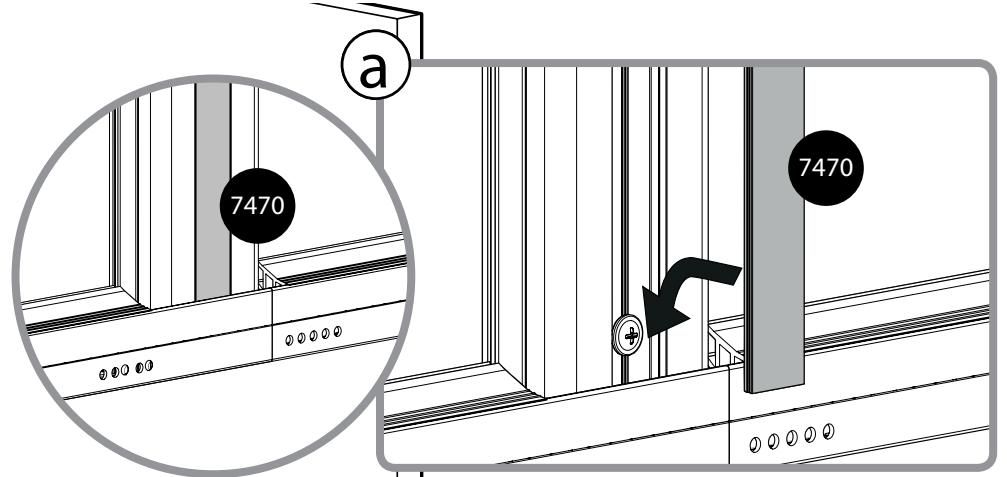
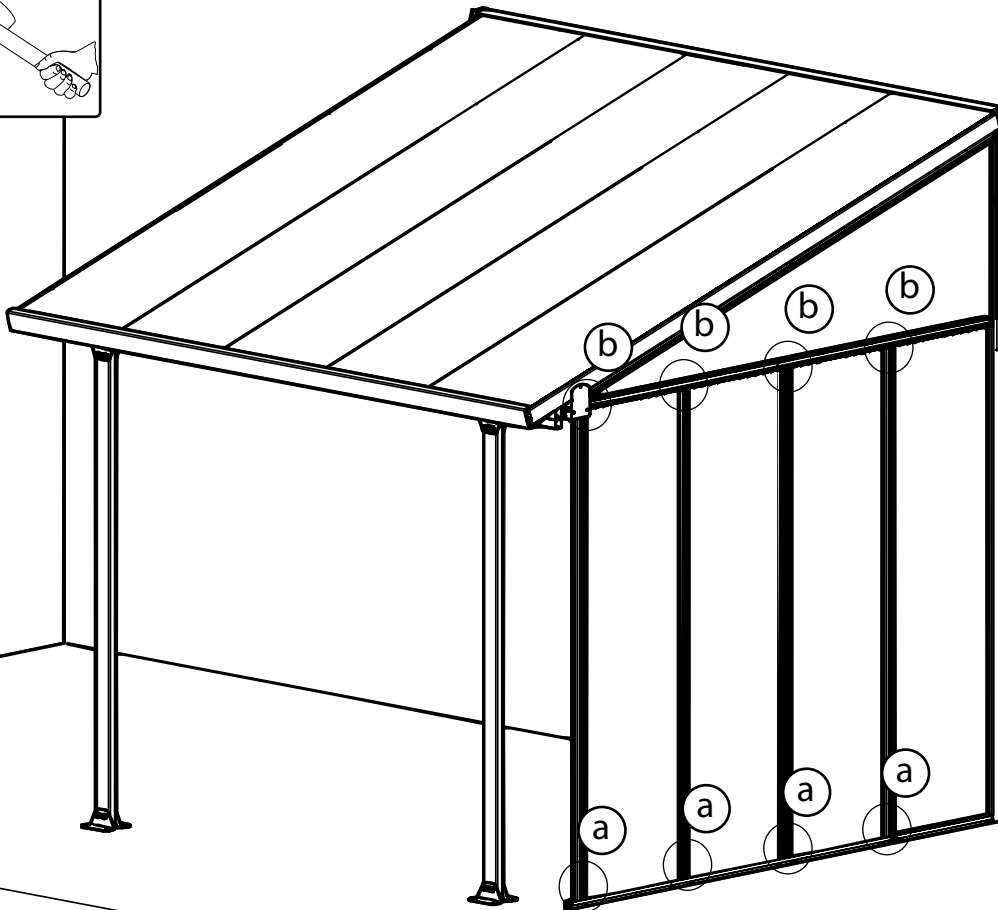
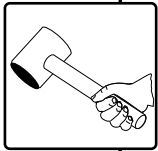

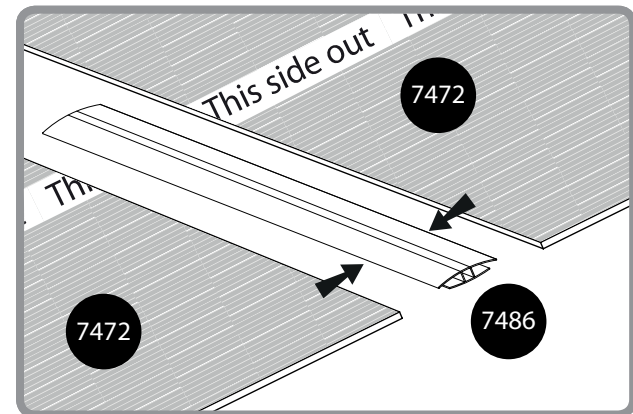
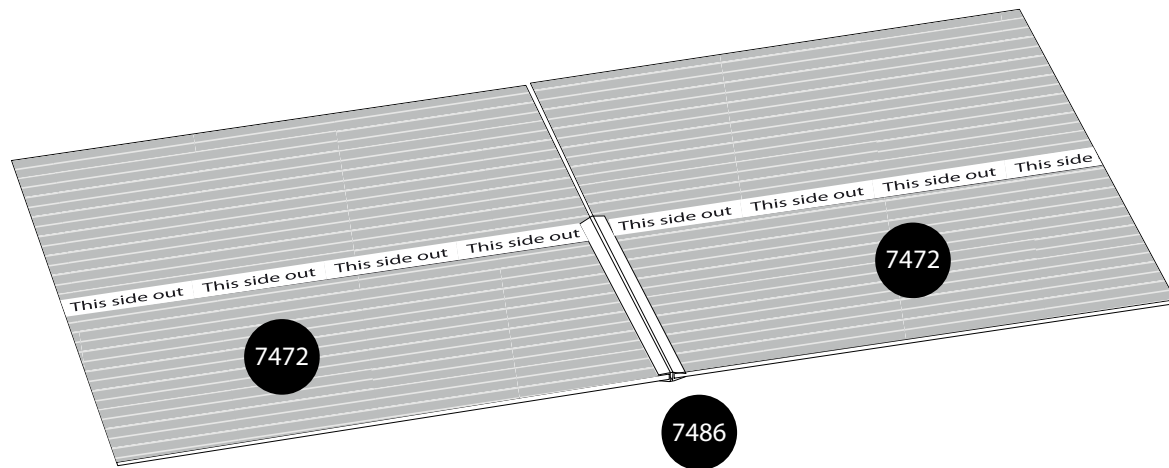
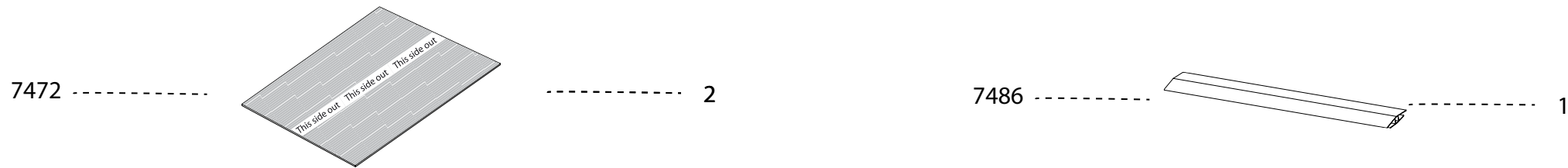

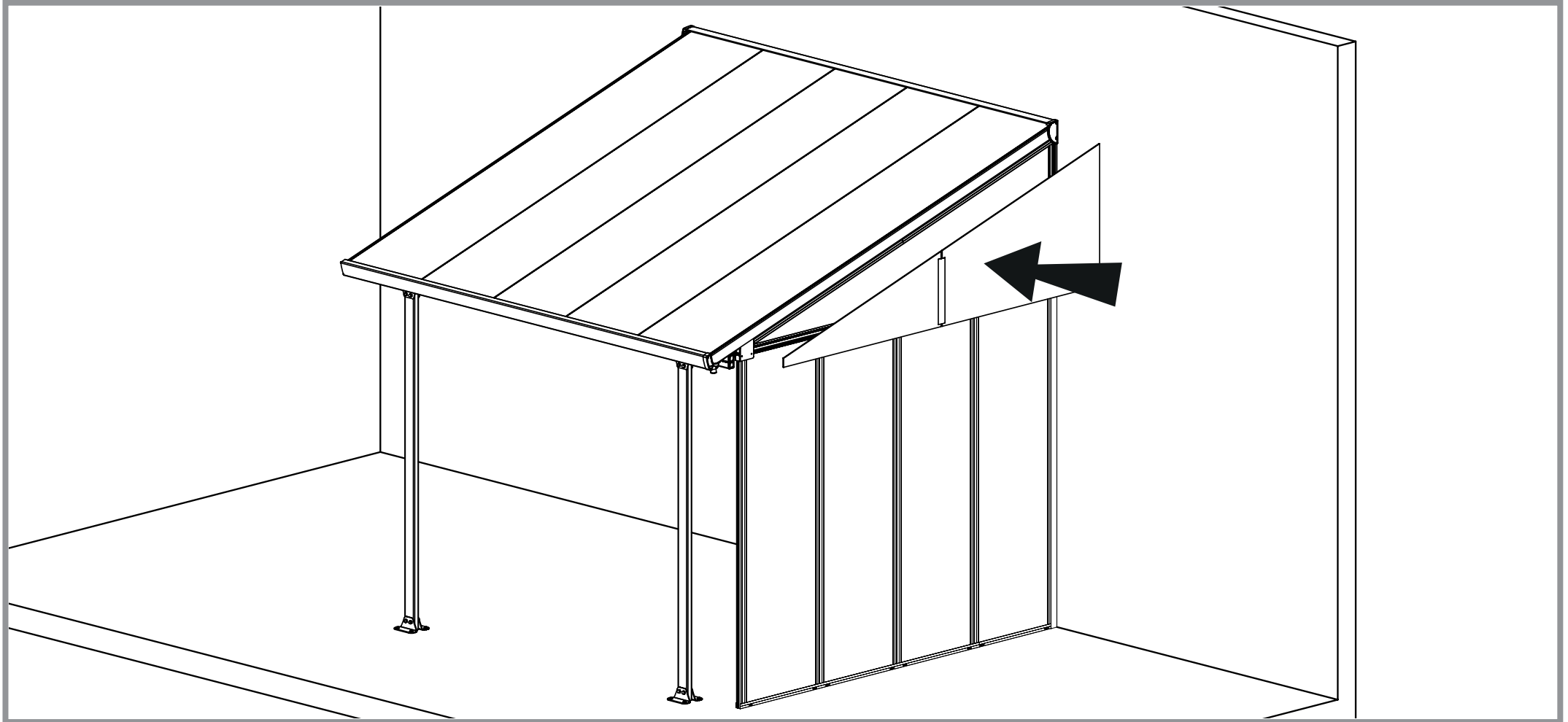
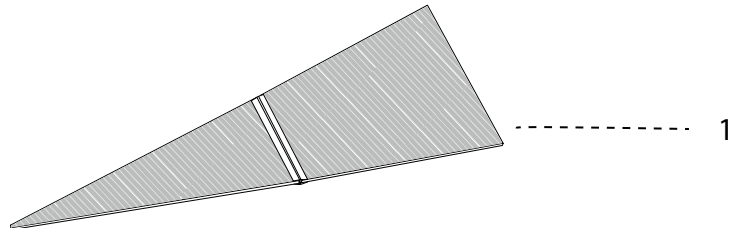

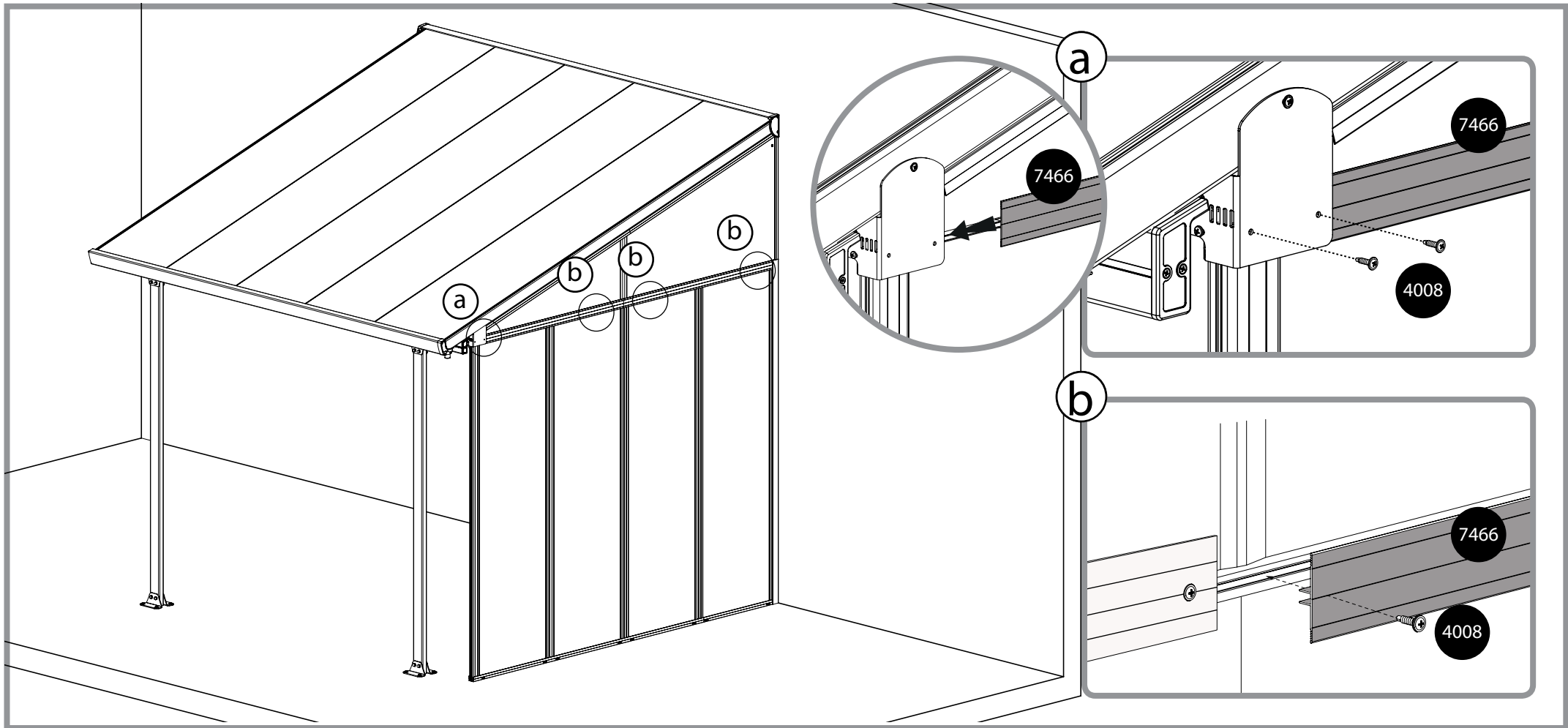
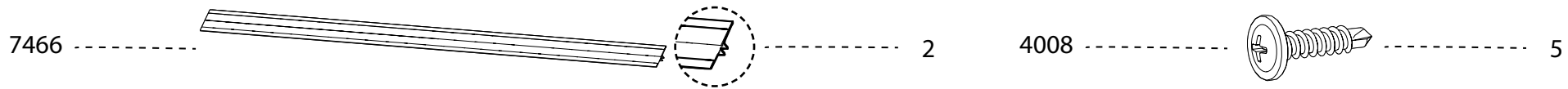

7473-----

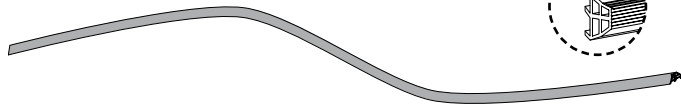

2

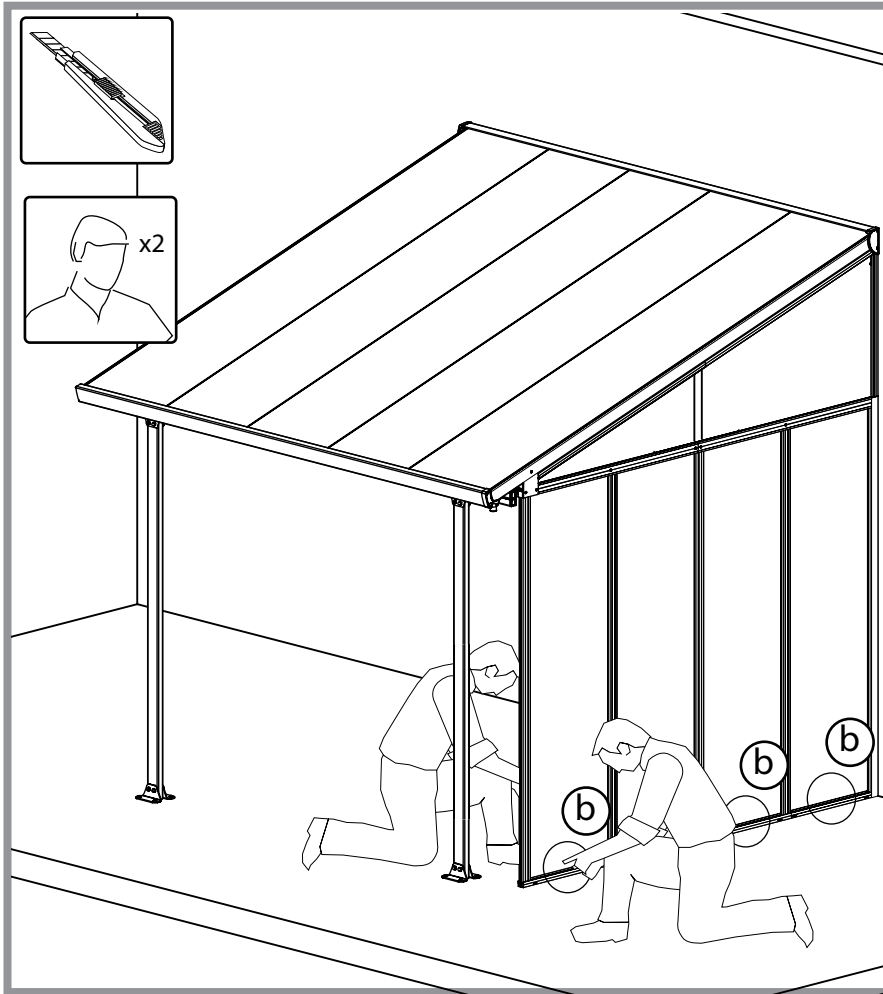
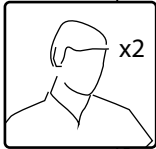
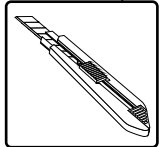

a

7473

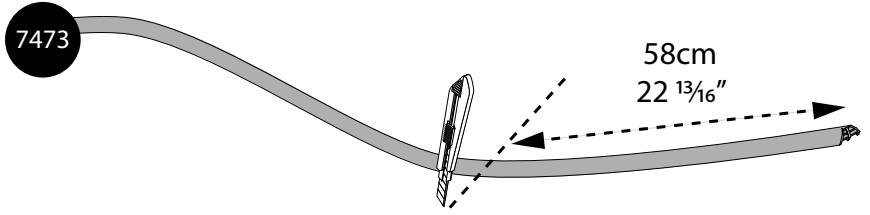

X8

b

7473

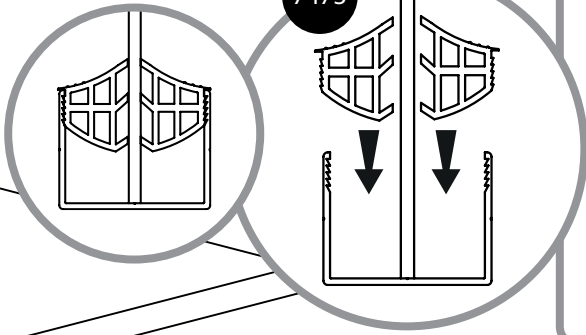

7473

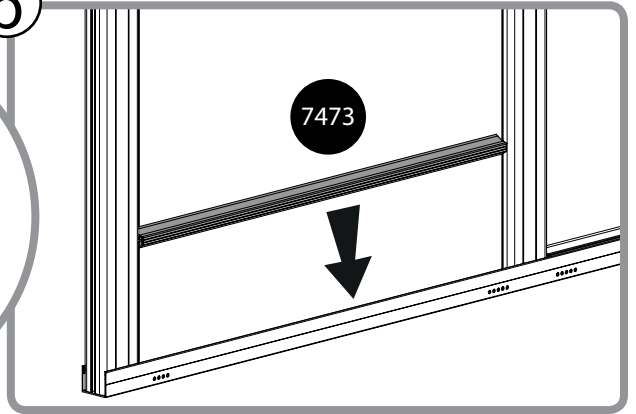

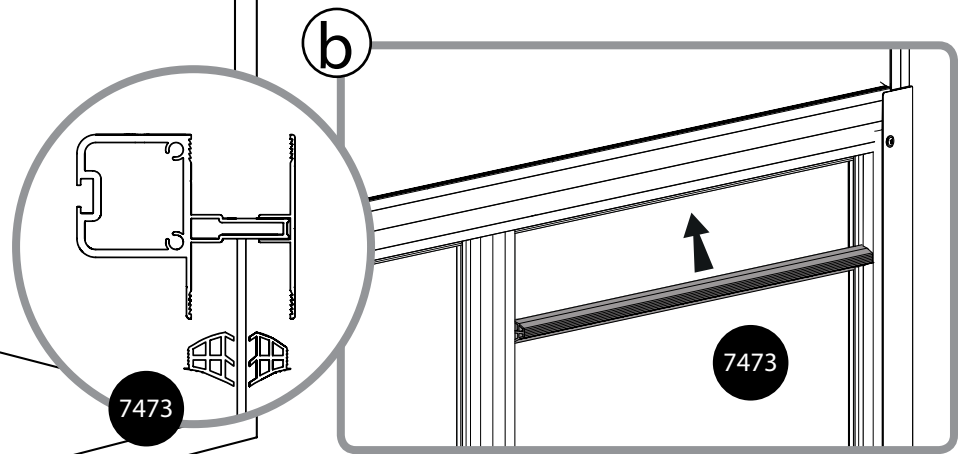
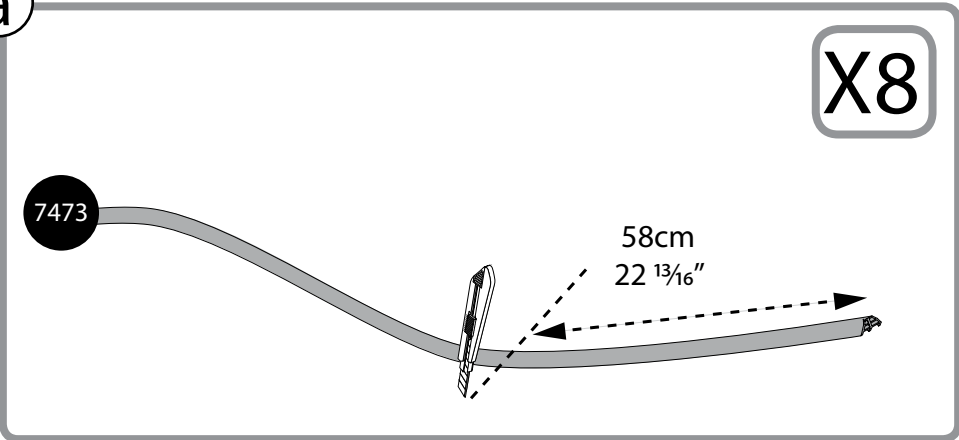
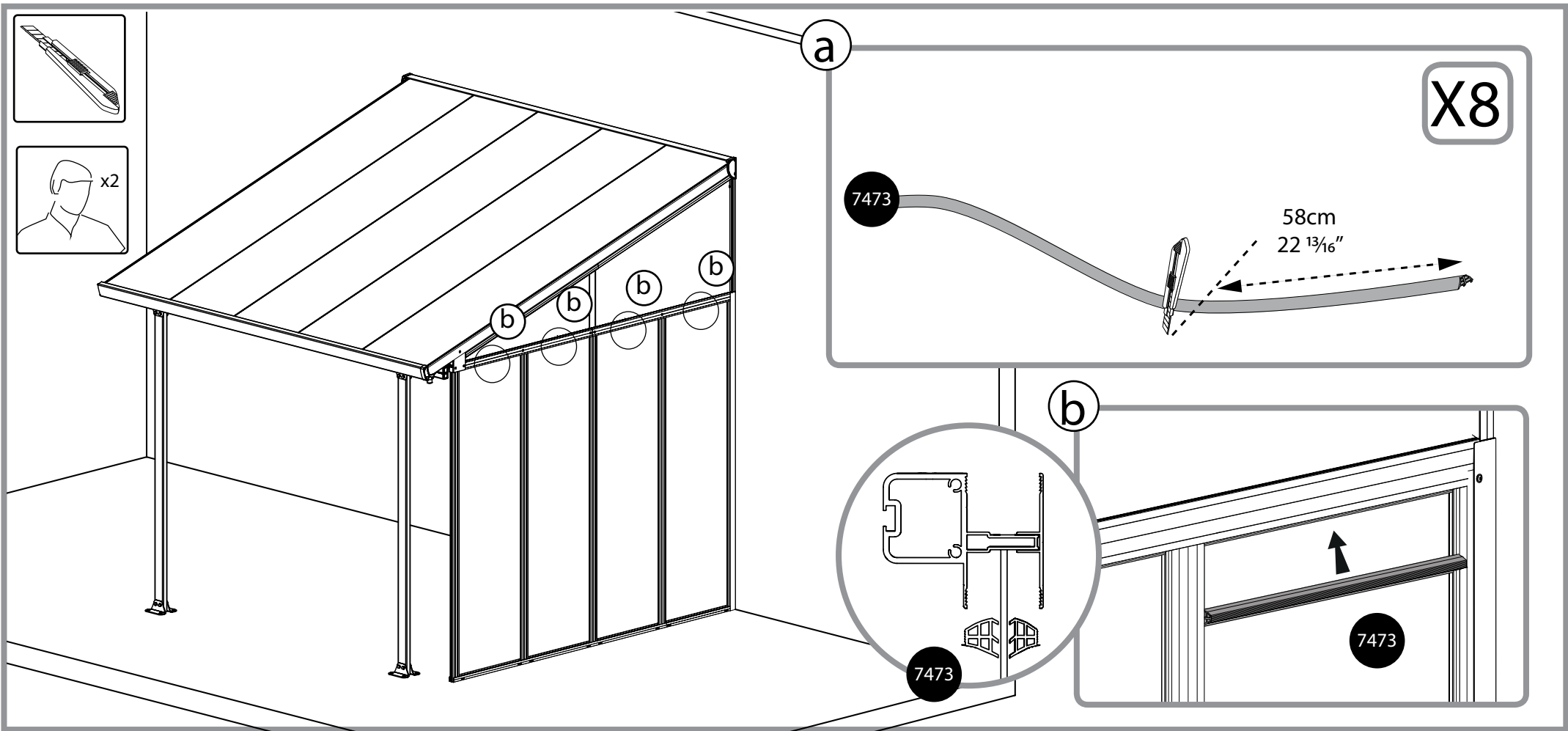
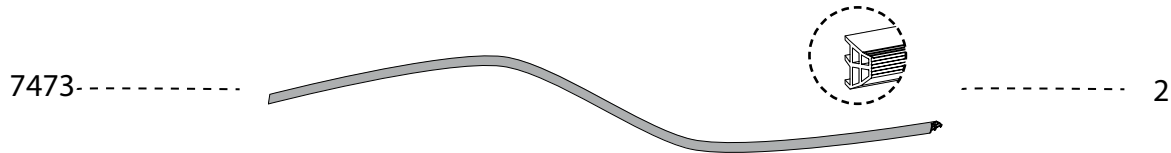

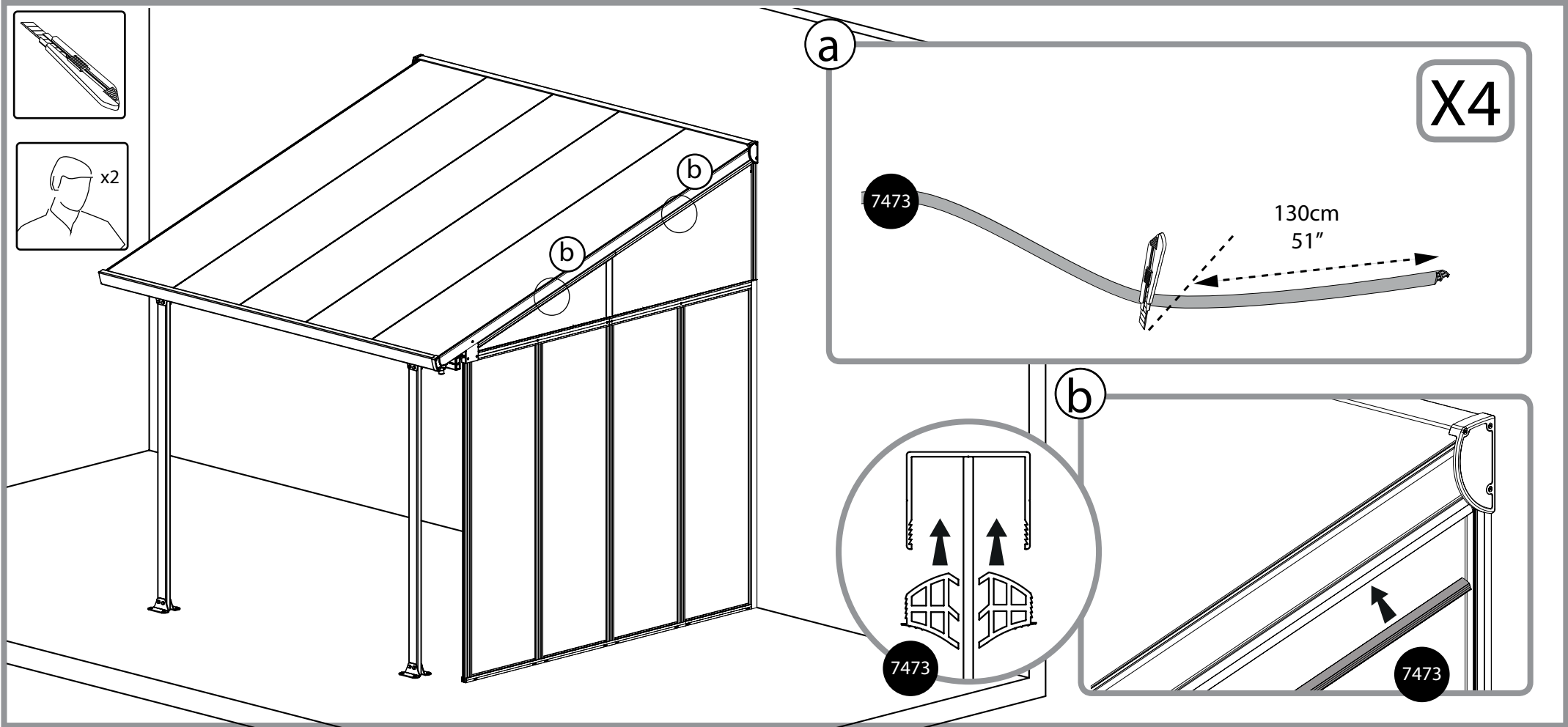
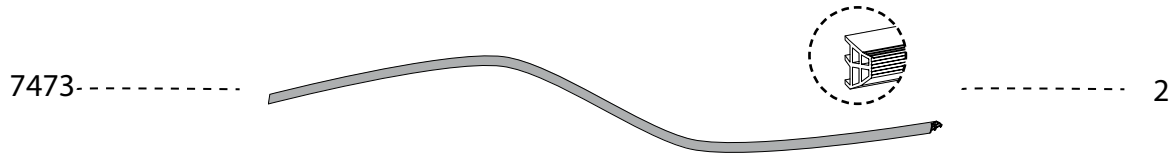

a

X4

7473

130cm
51"

b

7473

7473

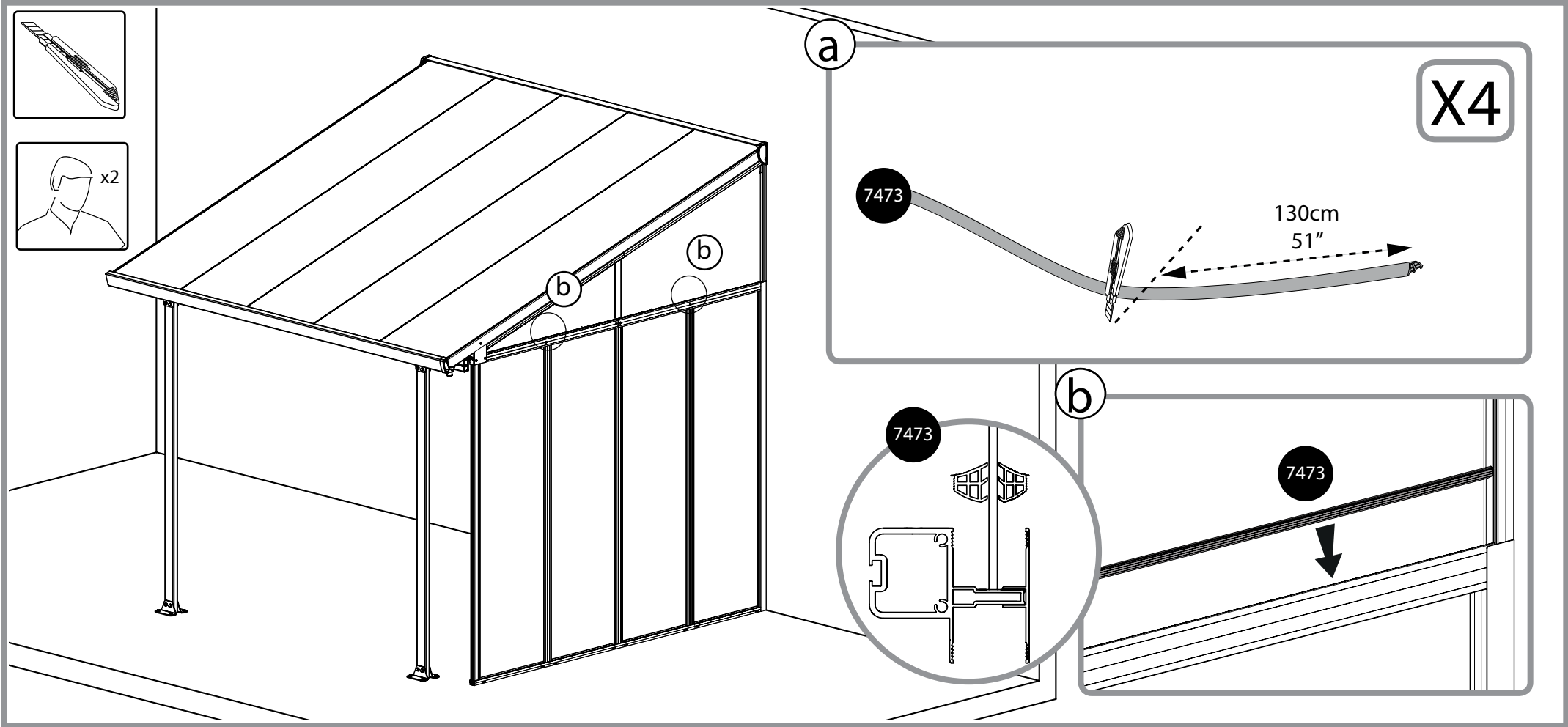
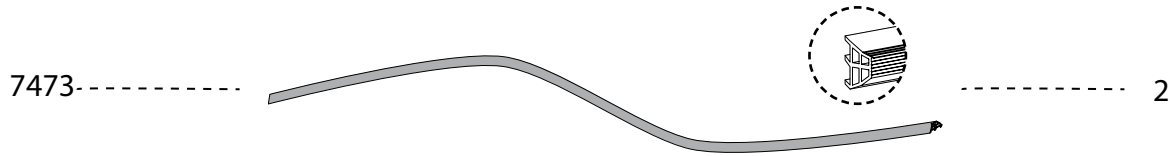

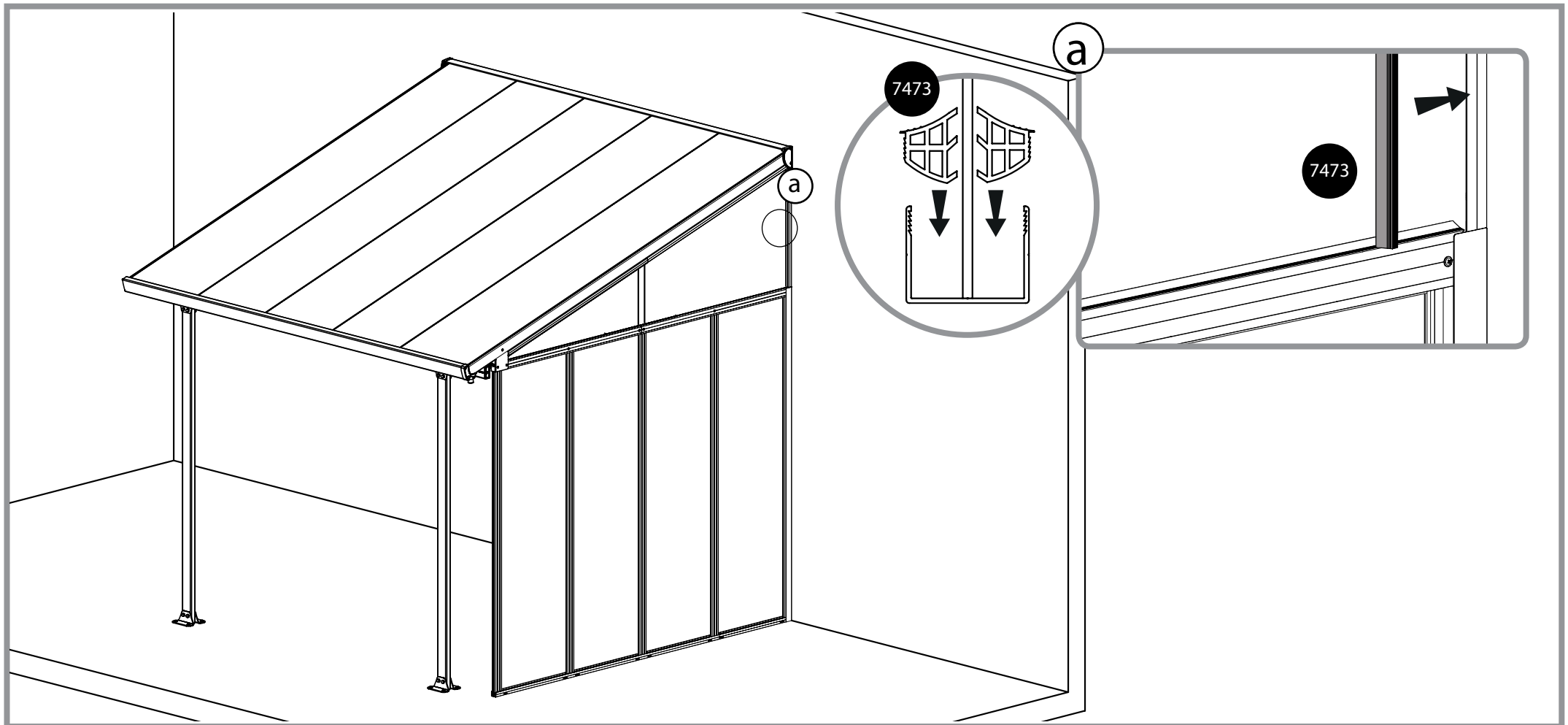
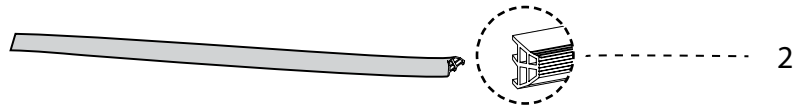

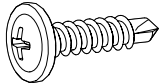
4008  6

