

Commercial Sling Wave Chaise Lounge

ITM./ART. # 1713483

**IMPORTANT, RETAIN FOR FUTURE REFERENCE: READ CAREFULLY
THE ITEM IS INTENDED FOR OUTDOOR COMMERCIAL AND DOMESTIC USE ONLY.**

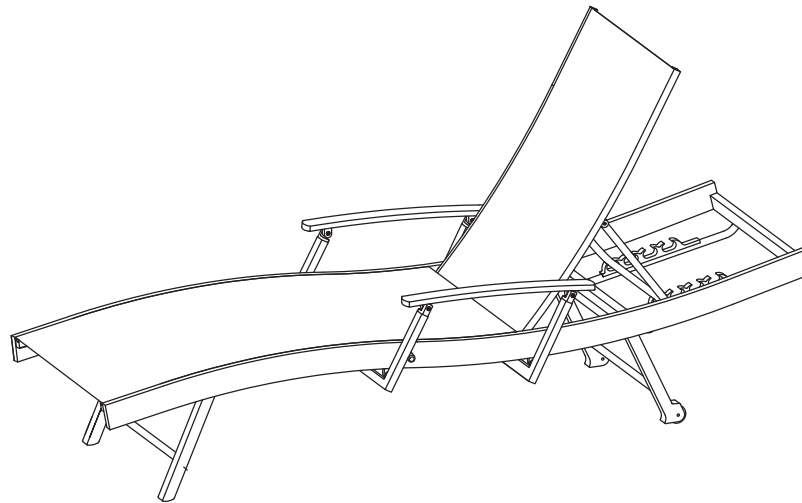

Questions, problems, missing parts?

Before returning to your retailer, call our customer service department at 1-888-690-9800 (8:00 a.m. – 5:00 p.m. PT / 11:00 a.m. – 8:00 p.m. ET, Monday – Friday. English and Spanish) or email us at service@sunvilla.com.

Preparation

Before beginning to assemble this product, make sure all parts are present. Compare parts with package contents list and hardware contents list. If any parts are missing or damaged, do not attempt to assemble this product. Stop and call our customer service center.



Estimated Assembly Time: 10 minutes. Tools Required for Assembly: Wrench (included).



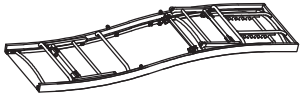

⚠ Safety Information

Please read and understand this entire manual before attempting to assemble or install the product. It should not be used as a toy or tool. Children should not engage in the operation, assembly, removal, or disassembly of the product.

Parts List

⚠ WARNING: To avoid damage to your new patio furniture, please use either the carton or another soft surface such as carpet as a working surface to prevent product damage during assembly.

PART NO.	DESCRIPTION	QTY
A	 Chaise Frame	2
B	 Arms	2

PART NO.	DESCRIPTION	QTY
AA	 Bolt	4
BB	 M6x15 Bolt	8
CC	 Washer	8
DD	 Wrench	1

IMPORTANT: Read carefully and retain for future reference.

Chaise Assembly

Step 1

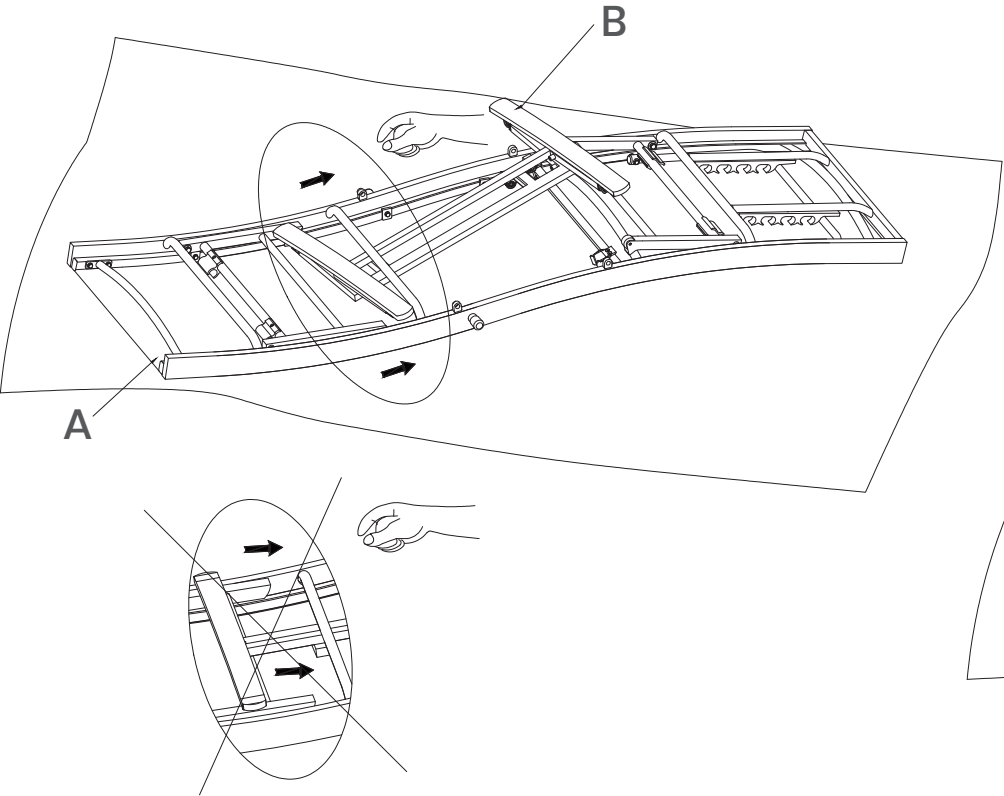

Step 2

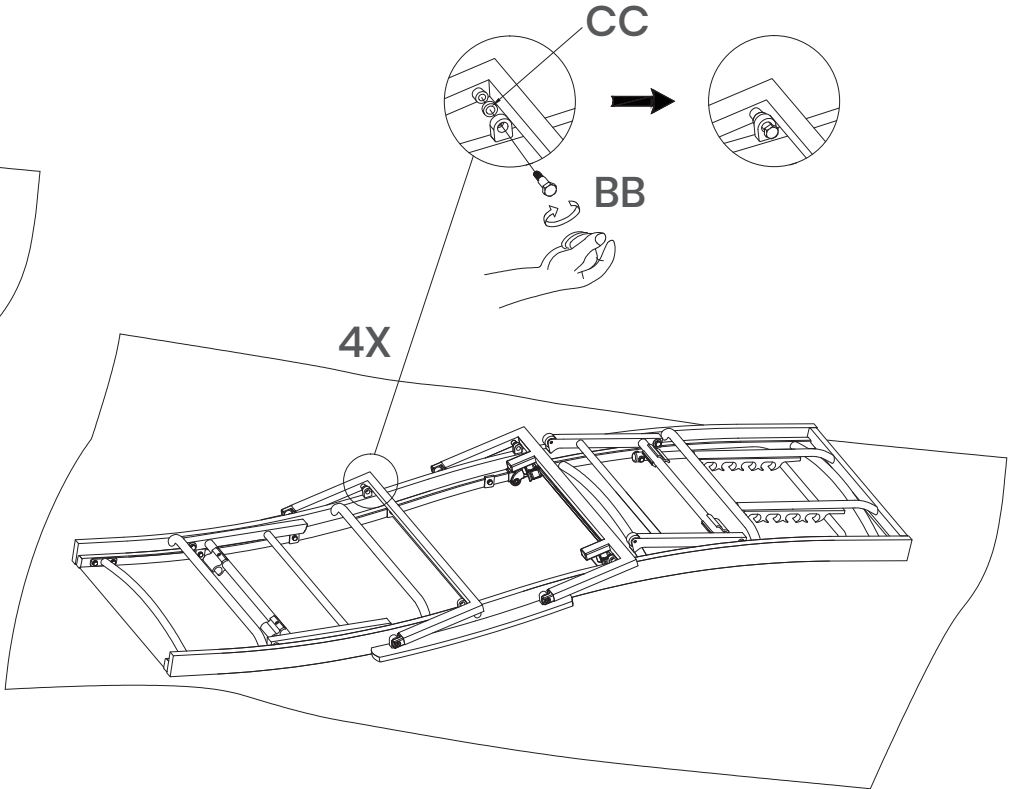

Chaise Assembly (cont.)

Step 3

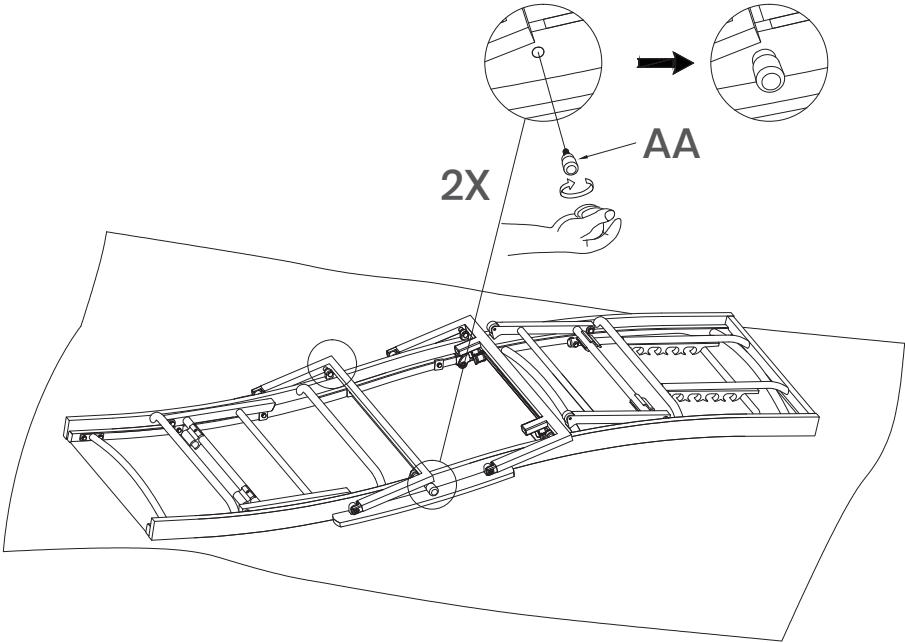

Step 4

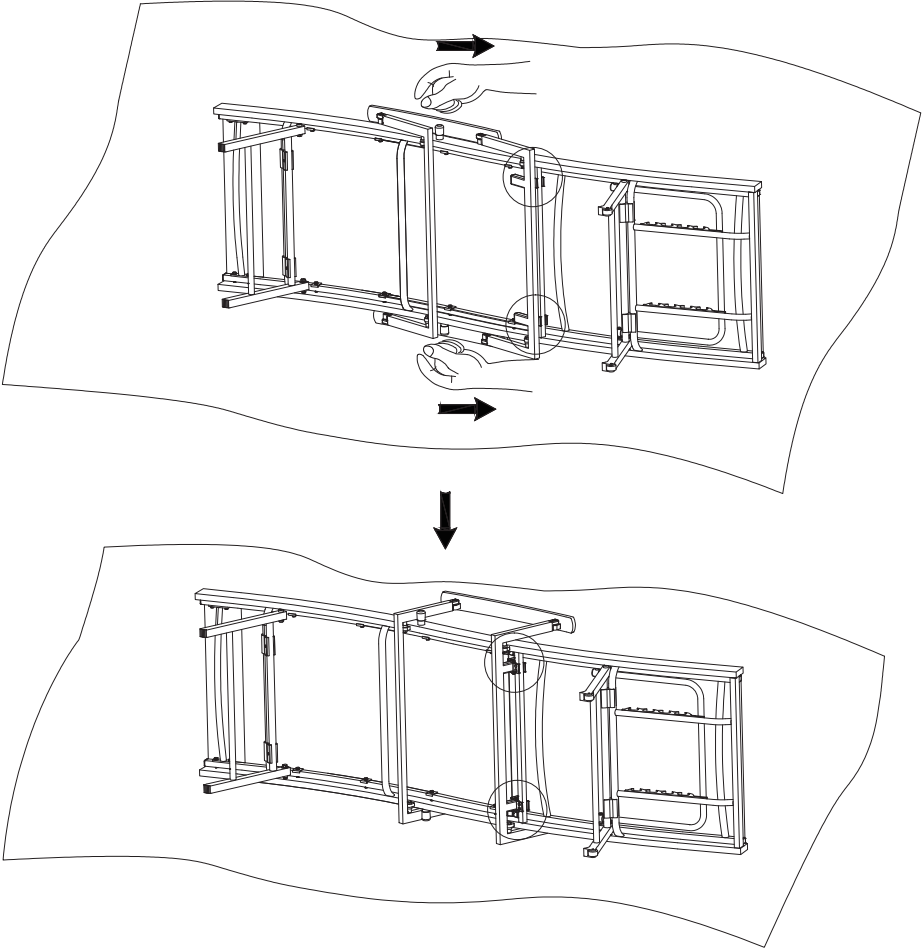

Chaise Assembly (cont.)

Step 5

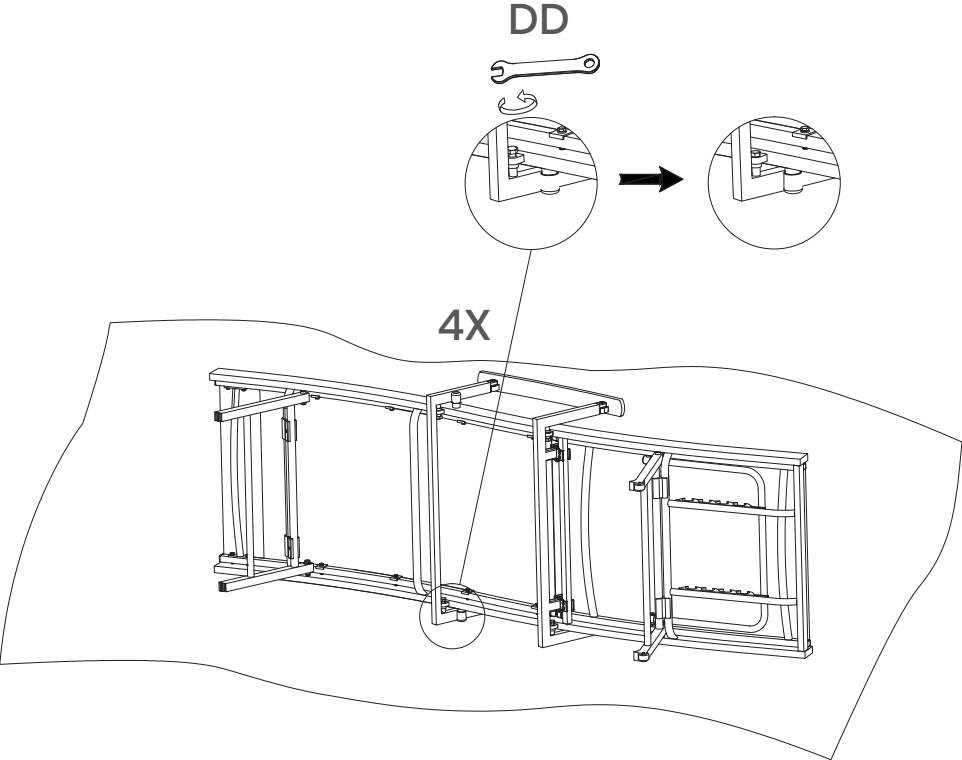

Step 6

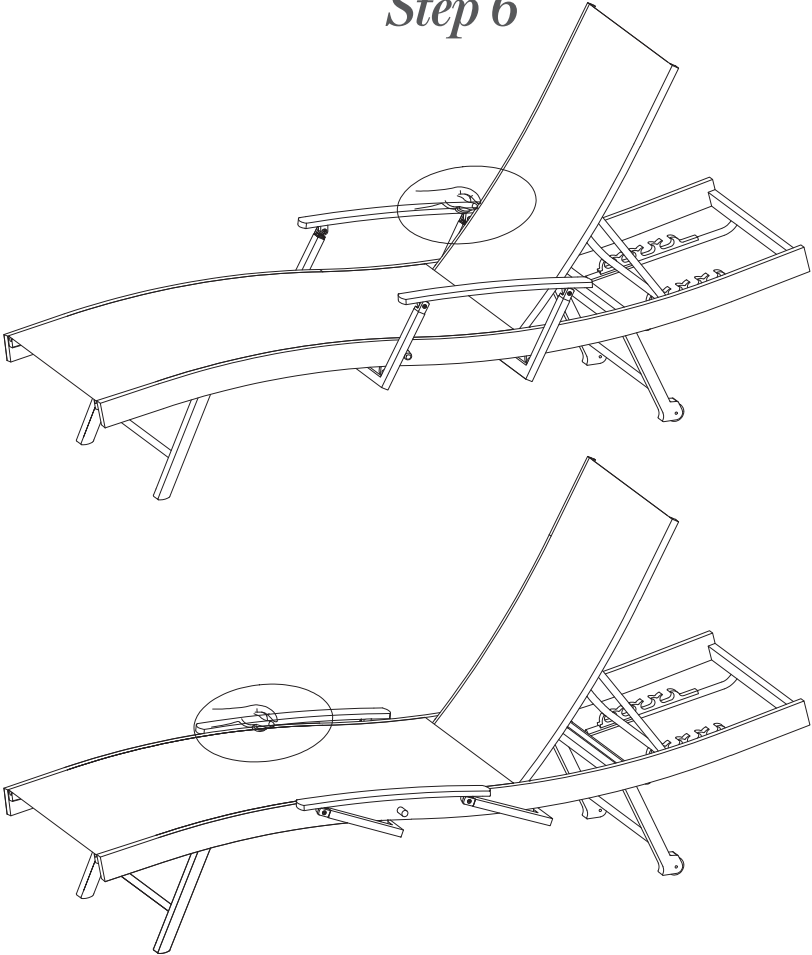

Warning: Pinch point. Watch your hands and fingers when opening and closing the arms.

Chaise Assembly(cont.)

Step 7

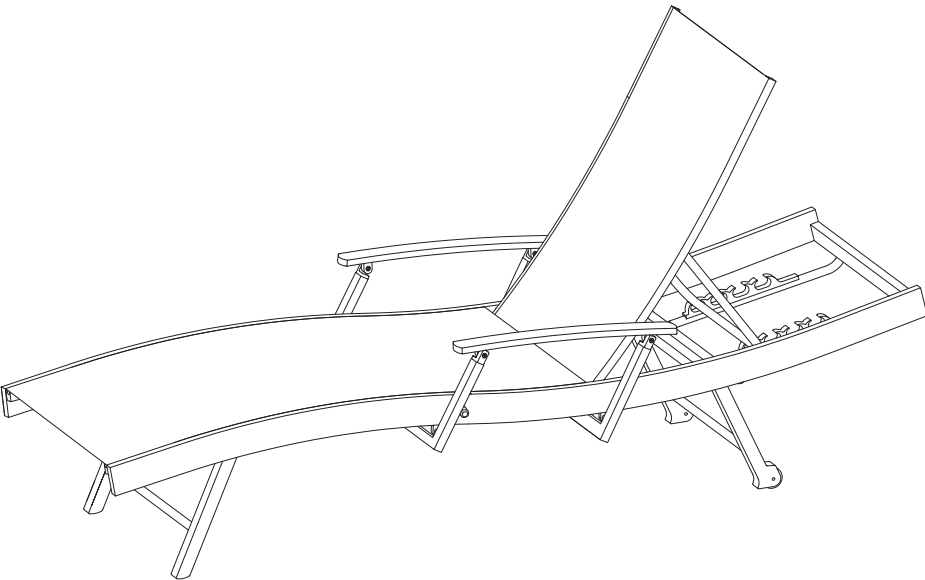

Step 8

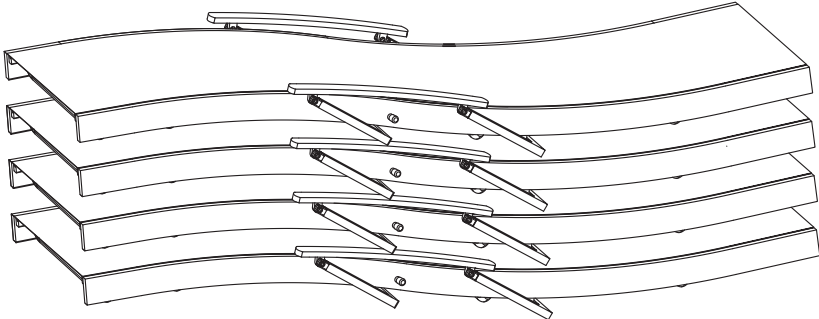

Care and Maintenance

Chaise Frame

To clean frame, use mild soap and water. Do not use abrasive materials, cleaners or products containing bleach. To maintain frame, clean thoroughly and let it dry. Drain any water that may have collected inside the frame. Water not drained and exposed to freezing temperatures may cause damage to the frame tubing.

Chaise Fabric

Phifer fabric should be cleaned regularly. Brush off any loose dirt and wash with a mild soap and lukewarm water solution. For stubborn stains and mildew, wash with a solution of 236 ml (1 cup) of bleach and 59 ml (1/4 cup) of mild soap per 3.8 l (1 gallon) of water. Rinse thoroughly to remove soap. Allow fabric to air dry.

NOTE: Do not machine wash.

Chaise longue ondulée en toile

ITM./ART. # 1713483

IMPORTANT, À CONSERVER POUR DE FUTURES BESOINS DE RÉFÉRENCE : À LIRE SOIGNEUSEMENT

CE PRODUIT EST DESTINÉ POUR L'UTILISATION COMMERCIALE ET DOMESTIQUE EN PLEIN AIR SEULEMENT.

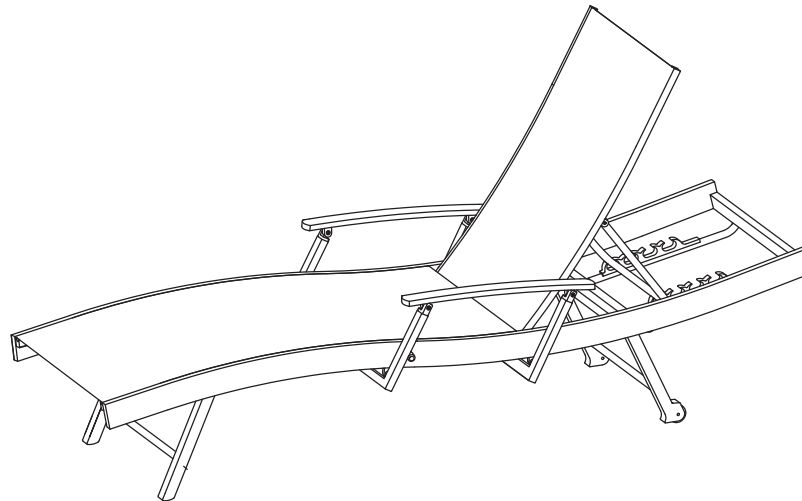

Questions? Pièces manquantes?

Avant de retourner chez le détaillant, communiquer avec le service à la clientèle au 1-888-690-9800, en semaine, entre 8 h et 17 h (heure du Pacifique) ou entre 11 h et 20 h (heure de l'Est), ou écrire à service@sunvilla.com. Service en anglais et en espagnol.

Préparation

Avant de commencer le montage, vérifier qu'il ne manque aucune pièce. Comparer le contenu de l'emballage avec la liste des pièces et de la quincaillerie. Si une pièce manque ou est brisée, ne pas assembler le produit; appeler le service à la clientèle.



Temps d'assemblage estimé : 10 minutes. Outils requis : Clé (comprise).



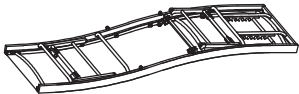

⚠ Consignes de sécurité

Lire attentivement le présent guide avant de commencer l'assemblage du produit. Ce n'est ni un jouet ni un outil. Les enfants ne doivent pas actionner, assembler, déplacer ou démonter le produit.

Liste des pièces

⚠ AVERTISSEMENT: Pour éviter d'endommager le produit pendant le montage, déposer les pièces sur le carton de l'emballage ou sur une autre surface douce comme un tapis.

No DE PIÈCE	DESCRIPTION	QTÉ
A	 Cadre de Chaise	2
B	 Accoudoir	2

No DE PIÈCE	DESCRIPTION	QTÉ
AA	 Boulon	4
BB	 M6x15 Boulon	8
CC	 Rondelle	8
DD	 Clé	1

IMPORTANT: Lire attentivement et conserver pour référence future.

Montage

Étape 1

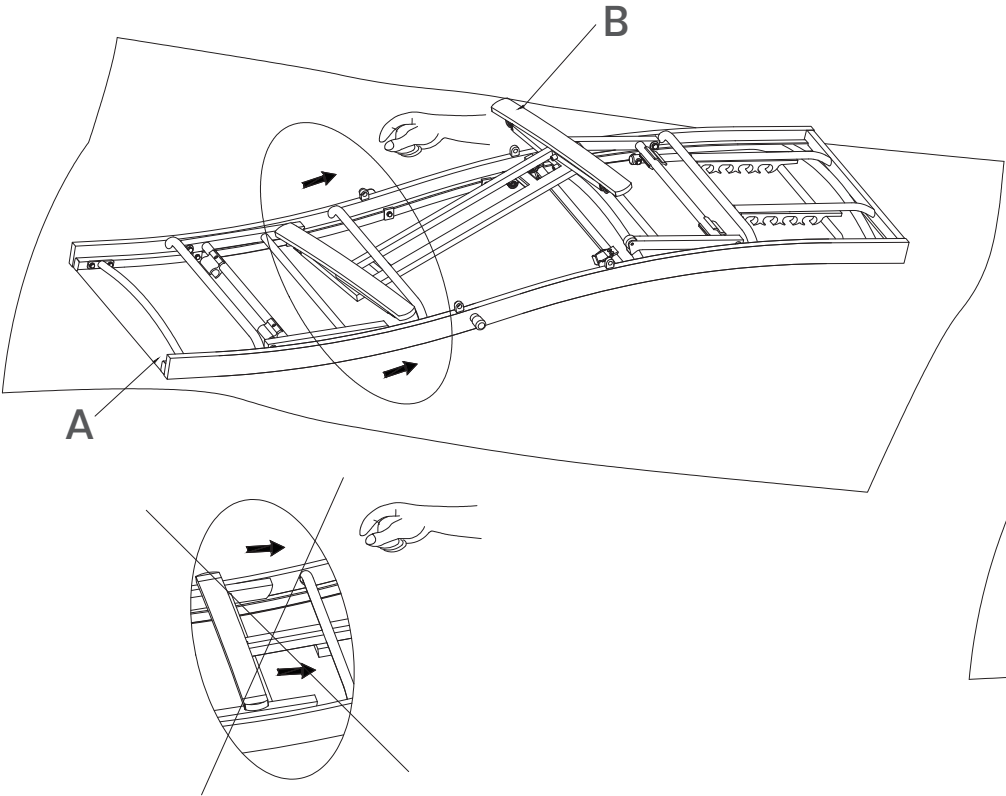

Étape 2

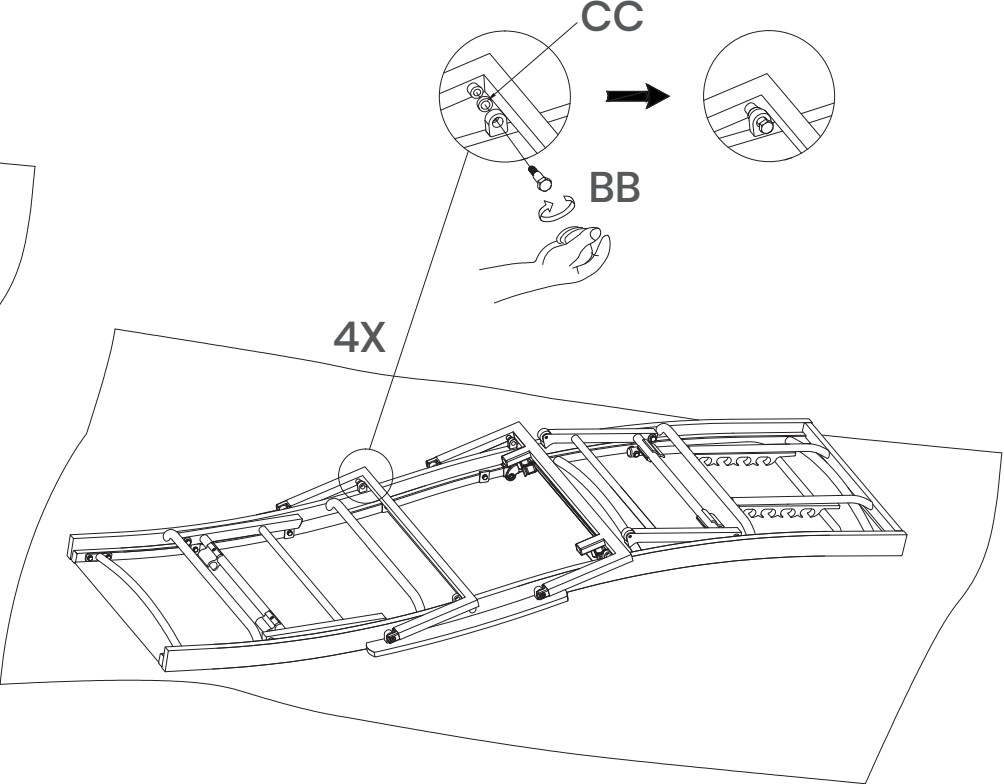

Montage (suite)

Étape 3

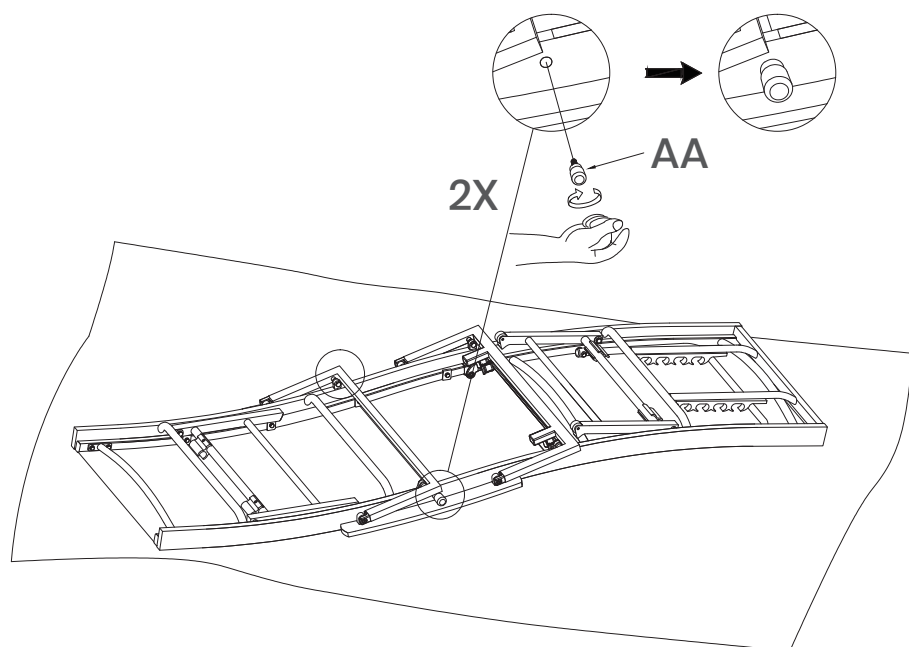

Étape 4

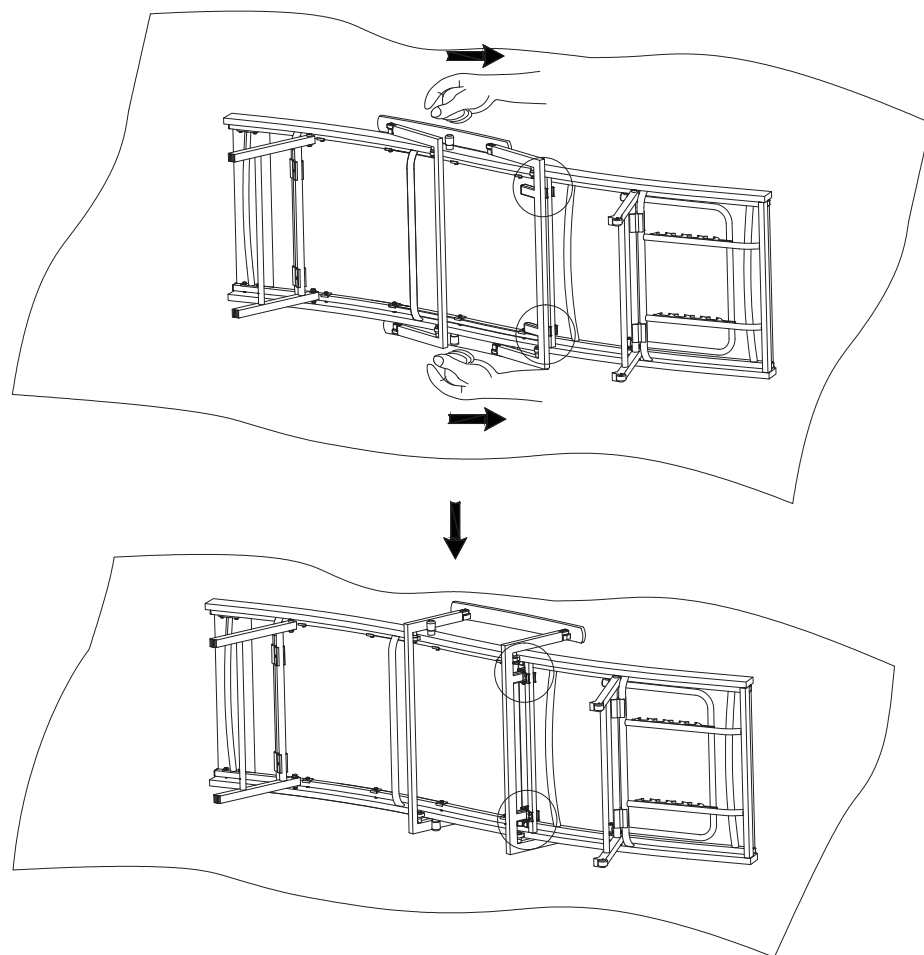

Montage (suite)

Étape 5

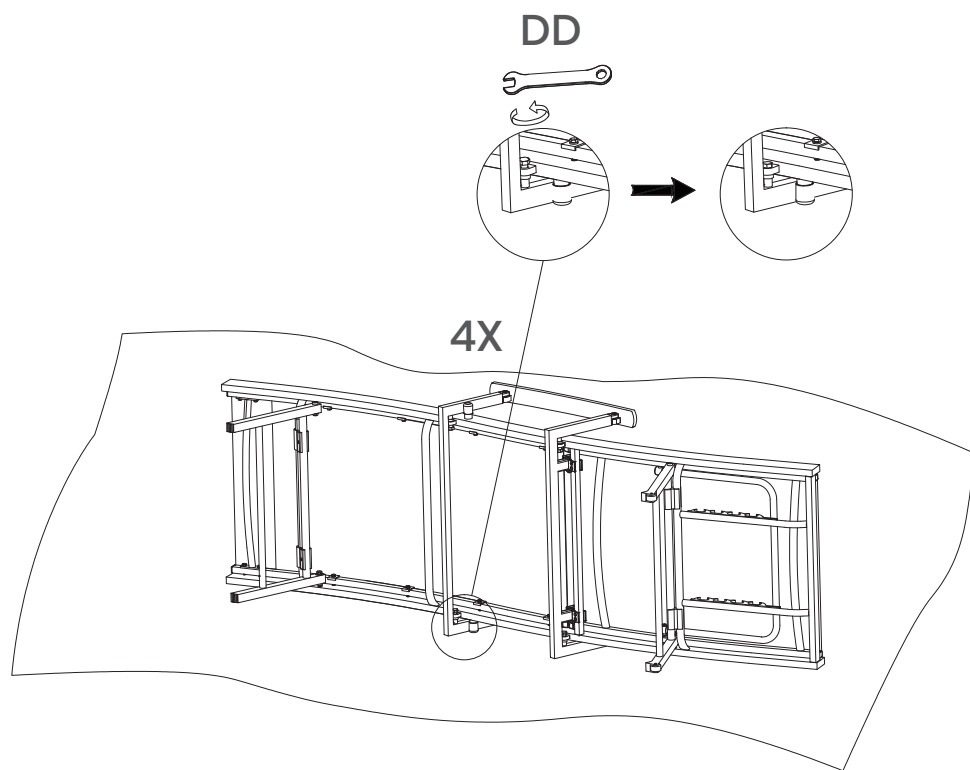

Étape 6

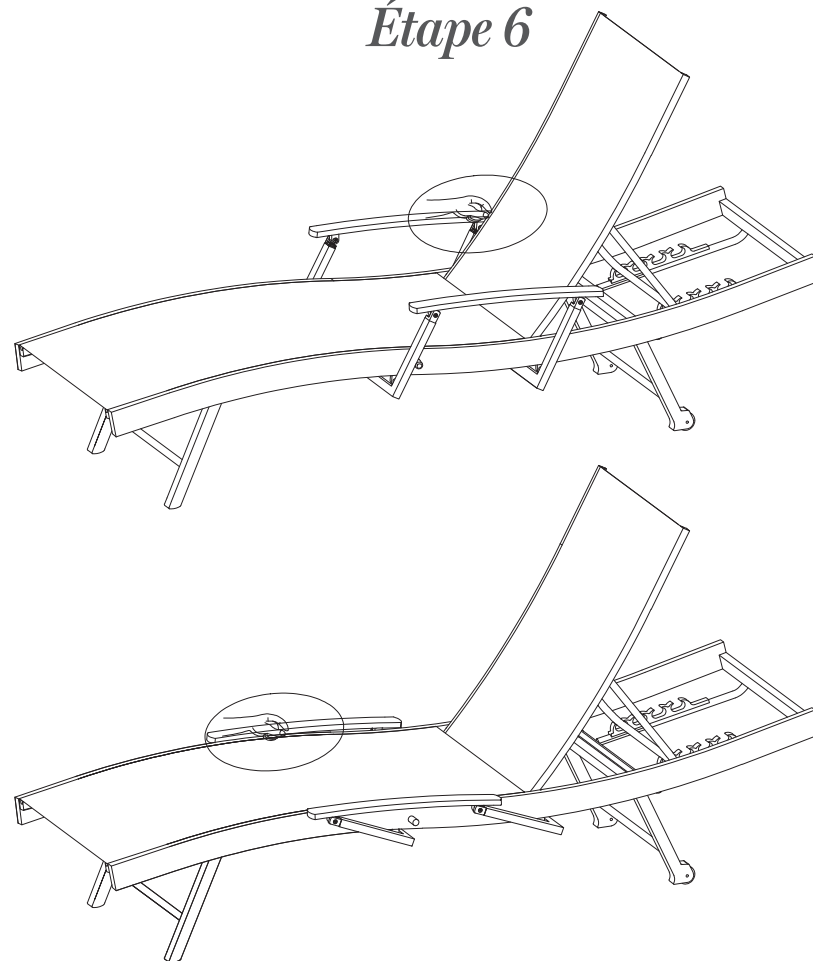

Avertissement : Point de pincement. Faire attention aux doigts et aux mains à l'ouverture et à la fermeture des accoudoirs.

Montage (suite)

Étape 7

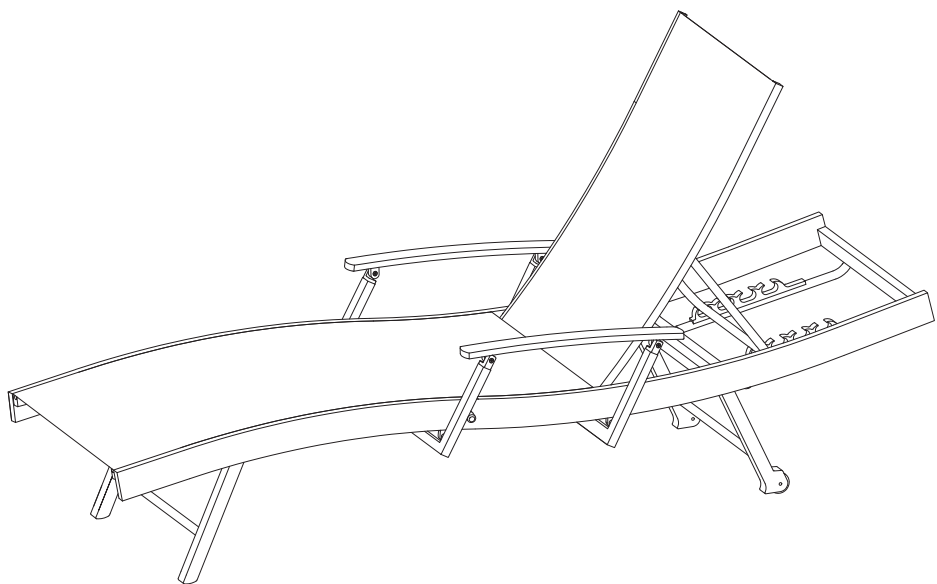

Step 8

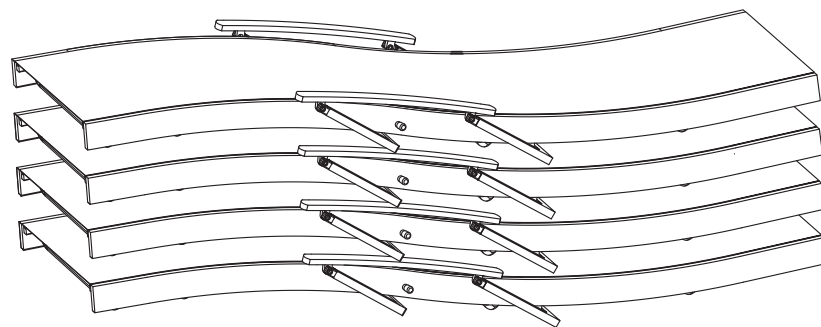

Entretien et maintenance

Cadre des chaises

Pour nettoyer le cadre, utiliser un savon doux et de l'eau.

Ne pas utiliser de produits de nettoyage abrasifs ou contenant un produit de blanchiment.

Pour protéger le cadre, le nettoyer à fond et le laisser sécher .

Évacuer l'eau qui pourrait s'être accumulée de nettoyage cadre.

L'eau non drainée exposée à des températures en dessous de zéro peut geler et endommager le cadre.

Tissu des chaises

Les tissus Phifer ® doivent être nettoyés régulièrement. Enlever la saleté avec une brosse et laver avec une solution de savon doux et d'eau tiède. Pour les taches tenaces et les moisissures, utiliser une solution de 236 ml (1 tasse) d'agent de blanchiment et de 59 ml (1/4 de tasse) de savon doux dans 3,8 l (1 gallon) d'eau. Rincer abondamment pour enlever le savon.

Laisser le tissu sécher à l'air.

N.B. : Ne pas laver à la machine.

Camastro curvo de tela de uso comercial

ITM./ART. # 1713483

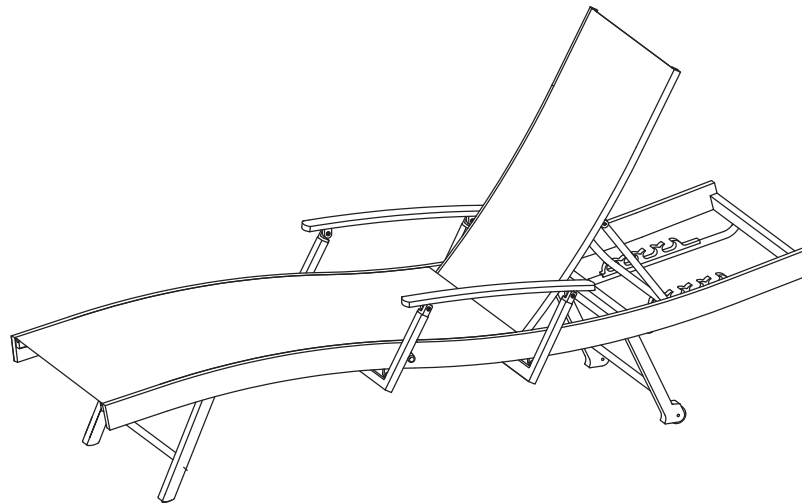
IMPORTANTE: CONSERVE PARA FUTURA REFERENCIA.**LEA CUIDADOSAMENTE****ESTE PRODUCTO ESTÁ DESTINADO PARA USO COMERCIAL Y DOMÉSTICO EN EXTERIORES ÚNICAMENTE****¿Preguntas, problemas o piezas faltantes?**

Antes de regresar el producto a la tienda, llame a nuestro departamento de Servicio al Cliente al 1-888-690-9800 o envíe un correo electrónico a service@sunvilla.com, de lunes a viernes, de 8:00 am a 5:00 pm, hora del Pacífico de E.U.A o de 11:00 am a 8:00 pm, hora del Este de E.U.A.

Inglés y español.

PREPARACIÓN



Antes de comenzar a ensamblar este producto, asegúrese que todas las piezas estén completas. Compare las piezas con el listado de contenido de piezas y de herramientas del empaque. No intente ensamblar el producto si faltase alguna pieza o si estuviera dañada. Si así fuera, no continúe y llame a nuestro centro de servicio al cliente. Tiempo estimado de ensamble: 10 minutos. Herramientas requeridas para el ensamble: Llave Inglesa (incluida)



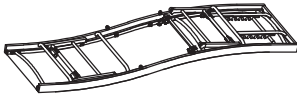

⚠ INFORMACIÓN DE SEGURIDAD

Por favor lea con atención este manual completo antes de ensamblar o instalar el producto. Los niños no deben participar en la operación, el ensamblaje, remoción o desmontaje del producto.

Lista de piezas

⚠ ADVERTENCIA : Para evitar daños en sus nuevos muebles de patio, utilice la caja de cartón u otra superficie blanda, como una alfombra, como área de trabajo para evitar daños en el producto durante su ensamblaje.

PIEZA NÚM.		DESCRIPCIÓN	CANT.
A		Armazón de la chaise	2
B		Brazo	2

PIEZA NÚM.		DESCRIPCIÓN	CANT.
AA		Perno	4
BB		M6x15 Perno	8
CC		Arandela	8
DD		Llave	1

IMPORTANTE: Conserve para futura referencia, lea cuidadosamente

Ensamblaje

Paso 1

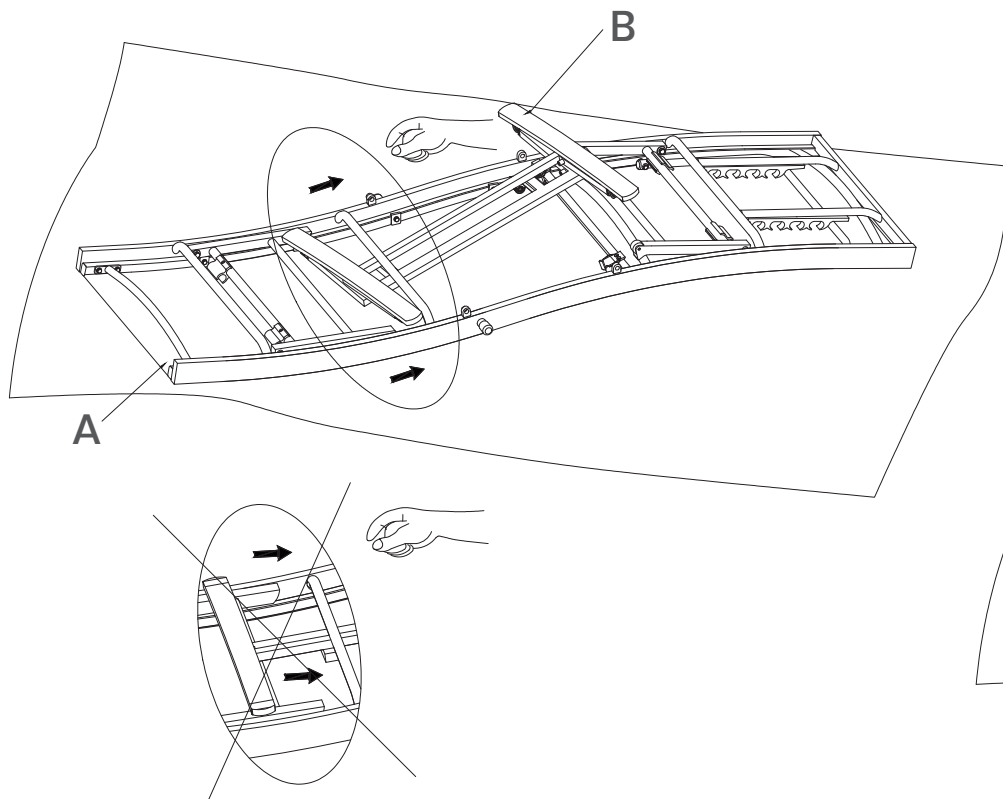

Paso 2

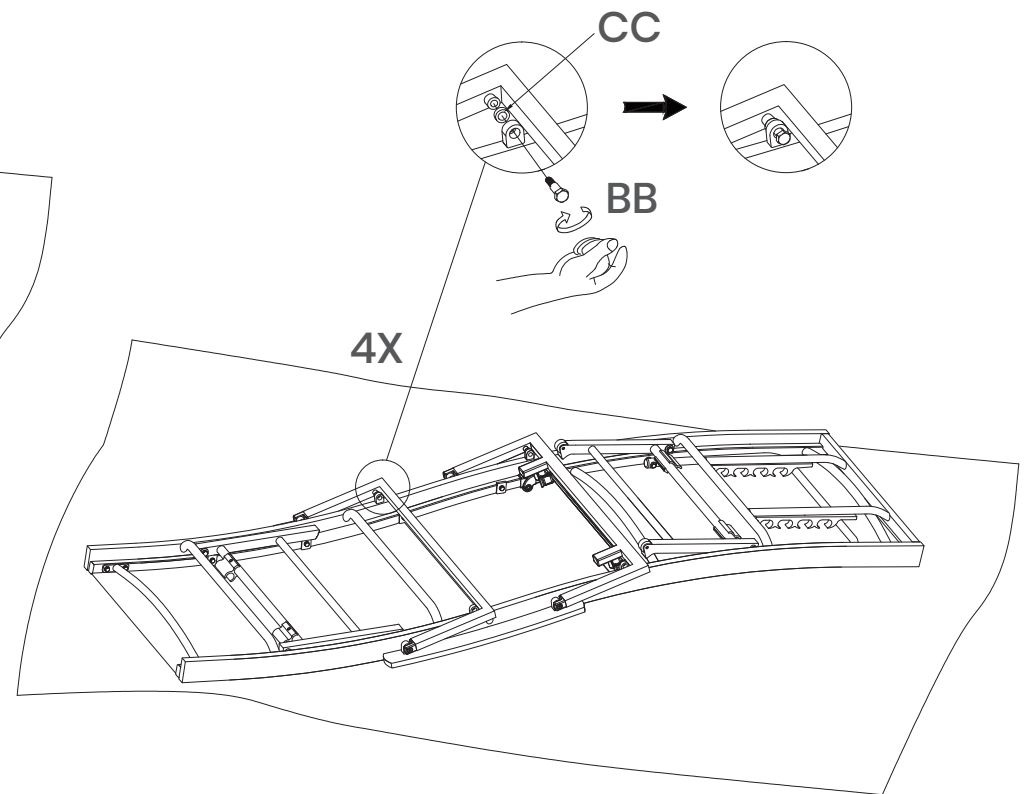

Ensamblaje (cont.)

Paso 3

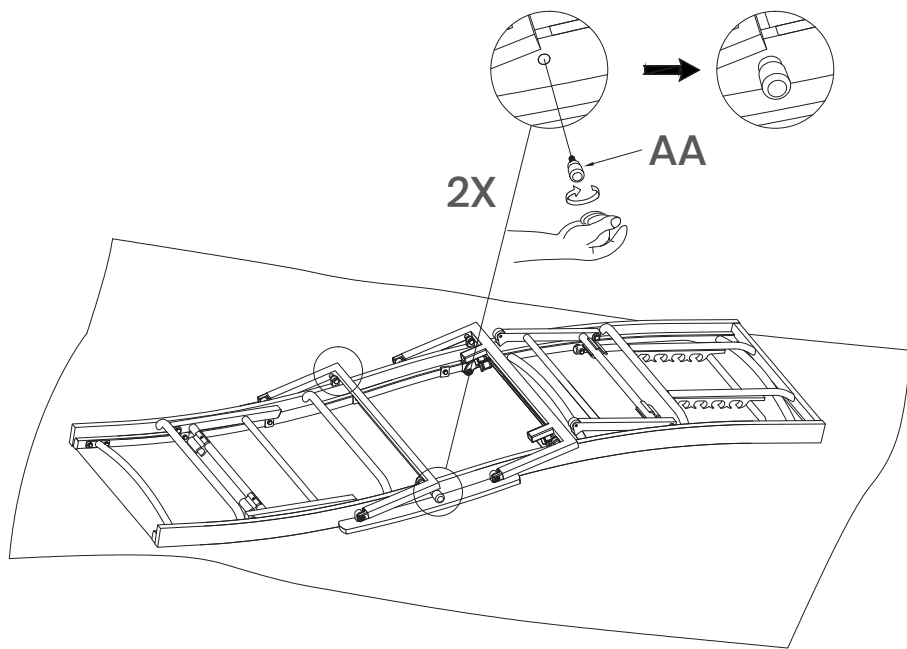

Paso 4

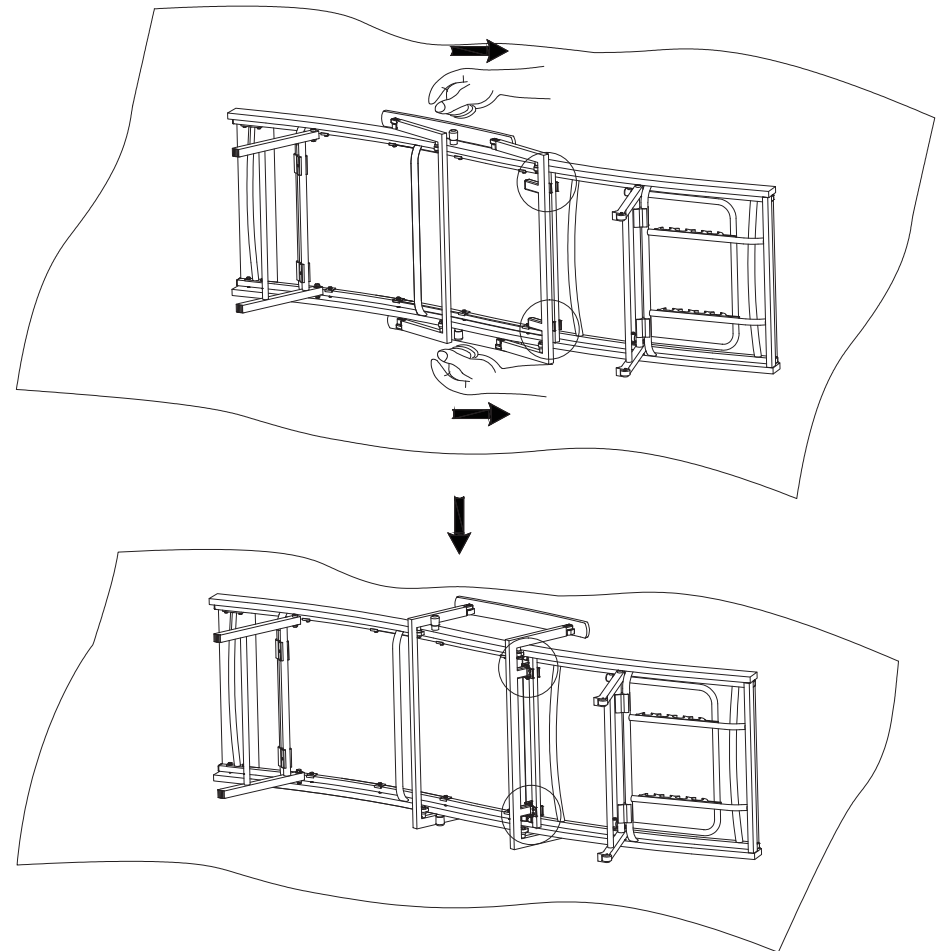

Ensamblaje (cont.)

Paso 5

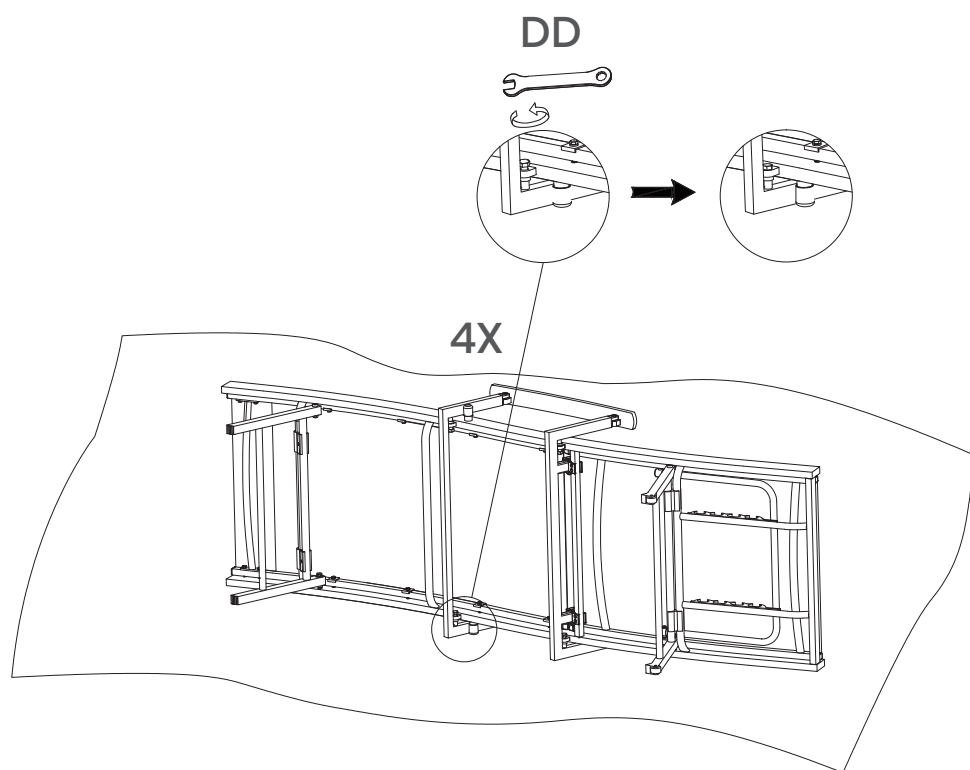

Paso 6

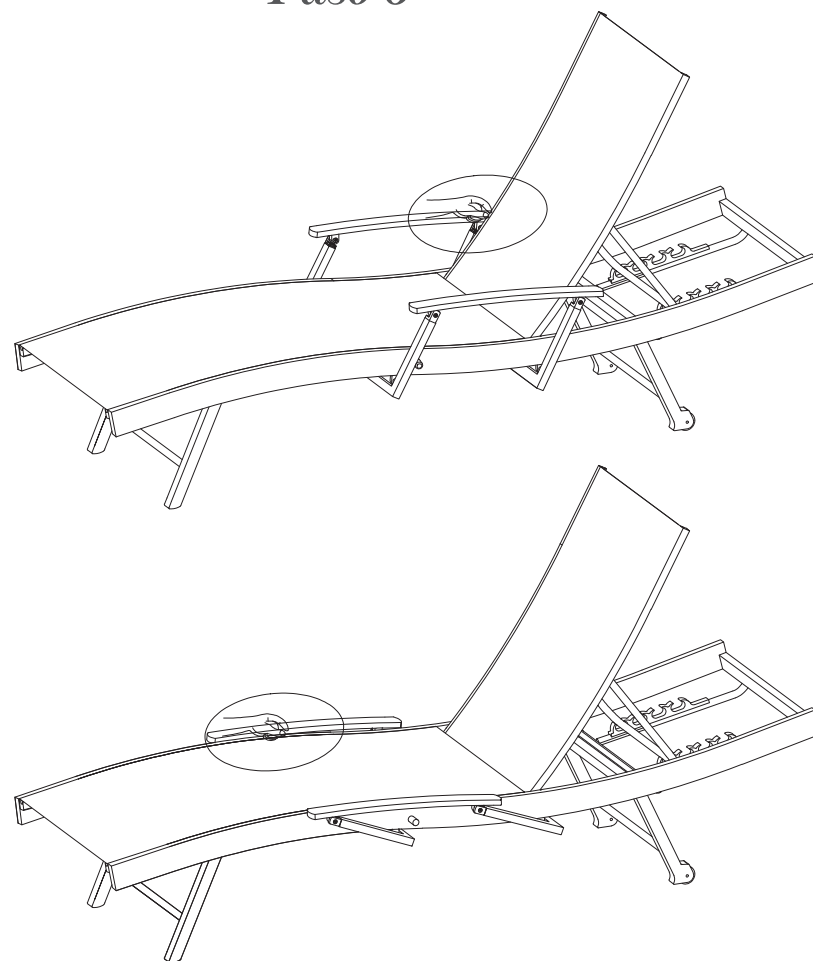

Advertencia: Punto de enganche. Cuida tus manos y dedos al abrir y cerrar los reposabrazos.

Ensamblaje (cont.)

Paso 7

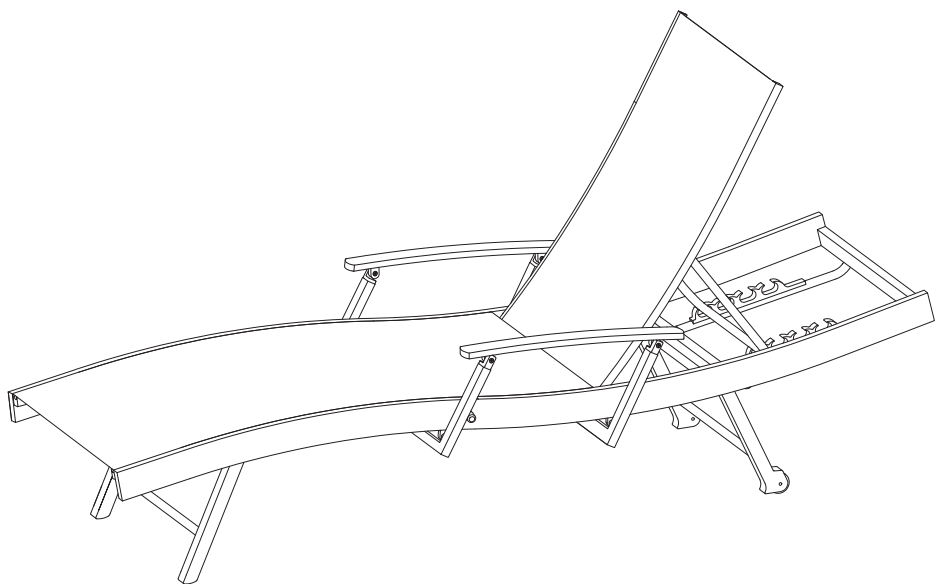

Step 8

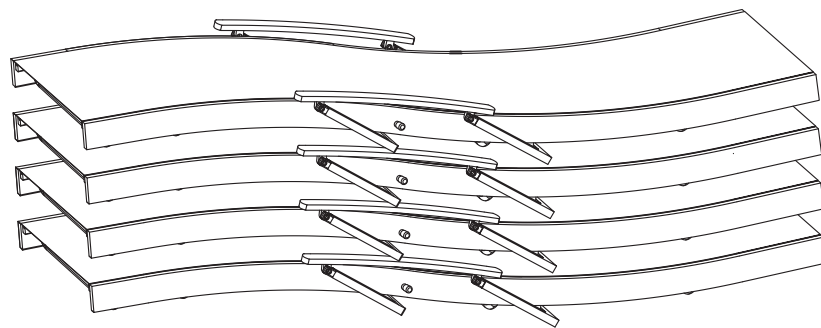

Cuidados y mantenimiento

Armazón de la silla

Para limpiar el armazón, utilice jabón suave y agua.

No utilice materiales abrasivos, limpiadores o productos que contengan blanqueador.

Para mantener el armazón, límpielo periódicamente y séquelo por completo.

Drene toda el agua que se podría haber acumulado dentro del armazón.

El agua no drenada y expuesta a temperaturas de congelación podría causar daños al entubado del armazón.

Tela de la silla

La tela Phifer® debe limpiarse regularmente. Elimine toda la suciedad suelta y lave con una solución de agua tibia y jabón suave. Para manchas difíciles y moho, lave con una solución de 236 mL (1 taza) de blanqueador y 59 ml (1/4 de taza) de jabón suave por cada 3,8 L (1 galón) de agua.

Enjuague bien para retirar el jabón.

Permita que la tela seque al aire.

Nota: No lave a máquina.

SUNVILLA

Distributed by:
Costco Wholesale
Corporation P.O. Box 34535
Seattle, WA 98124-1535
USA
1-800-774-2678
www.costco.com

Costco Wholesale Canada Ltd.*
415 W. Hunt Club Road
Ottawa, Ontario
K2E 1C5, Canada
1-800-463-3783
www.costco.ca
* faisant affaire au Québec sous
le nom les Entrepôts Costco

Importado por:
Importadora Primex S.A. de C.V.
Blvd. Magnocentro No. 4
San Fernando La Herradura
Huixquilucan, Estado de México
C.P. 52765
RFC: IPR-930907-S70
(55)-5246-5500
www.costco.com.mx

Costco Wholesale Australia Pty Ltd
17-21 Parramatta Road
Lidcombe NSW 2141
Australia
www.costco.com.au

Costco Wholesale UK Ltd /
Costco Online UK Ltd
Hartspring Lane
Watford, Herts
WD25 8JS
United Kingdom
01923 213113
www.costco.co.uk

Costco Wholesale Spain S.L.U.
Polígono Empresarial Los Gavilanes
C/ Agustín de Betancourt, 17
28906 Getafe (Madrid) España
NIF: B86509460
900 111 155
www.costco.es

Costco Wholesale Iceland ehf.
Kauptún 3-7, 210 Gardabaer
Iceland
www.costco.is

Costco France
1 avenue de Bréhat
91140 Villebon-sur-Yvette
France
01 80 45 01 10
www.costco.fr

Costco Wholesale Japan Ltd.
2 Kakuchi, 2 Gaiku, Kaneda-Nishi
361 Urikura, Kisarazu shi
Chiba, 292-0007 Japan
0570-200-800
www.costco.co.jp

Costco Wholesale Korea, Ltd.
40, Iljik-ro
Gwangmyeong-si
Gyeonggi-do, 14347, Korea
1899-9900
www.costco.co.kr

Costco Wholesale New Zealand Limited
2 Gunton Drive
Westgate
Auckland 0814
New Zealand
www.costco.co.nz

Costco (China) Investment Co., Ltd.
Room 01 Mezzanine
No. 5178, Kang Xin Highway
Pudong New District
Shanghai
China 201315
+86-21-6257-7065

Costco Wholesale Sweden AB
Box 614
114 11 Stockholm
Sweden
www.costco.se

MADE IN CHINA
FABRIQUÉ EN CHINE
HECHO EN CHINA