

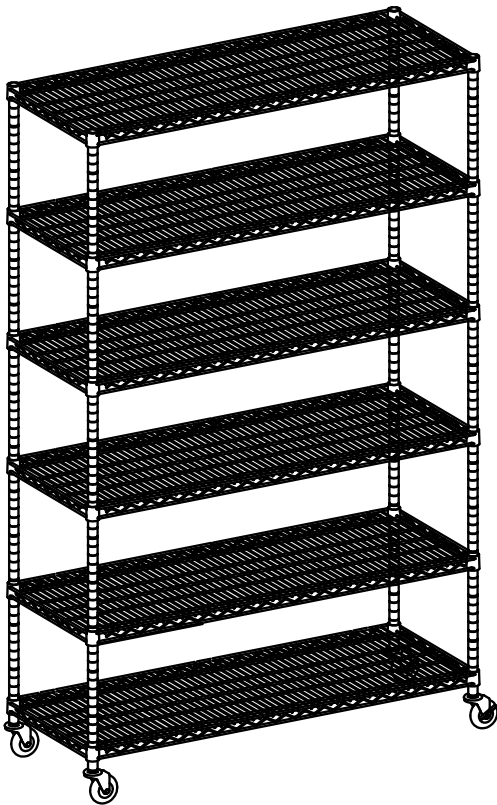

**OWNER'S MANUAL
GUIDE DE L'UTILISATEUR
MANUAL DEL PROPIETARIO**



**TRINITY ECOSTORAGE® 6-TIER NSF
WIRE SHELVING RACK W / WHEELS**

**ÉTAGÈRE NSF À TABLETTES
GRILLAGÉES À 6 NIVEAUX AVEC
ROULETTES TRINITY ECOSTORAGE®**

**TRINITY ECOSTORAGE® ESTANTE
DE ALAMBRE DE 6 REPISAS CON
RUEDAS**

**Model / Modèle / Modelo
CTBFZ-0945 / TBFZ-0945**

IMPORTANT, RETAIN FOR FUTURE REFERENCE: READ CAREFULLY

**IMPORTANT, CONSERVER CES DIRECTIVES AUX FINS DE
CONSULTATION ULTÉRIEURE: LIRE ATTENTIVEMENT**

**IMPORTANTE, GUARDAR PARA FUTURA REFERENCIA:
LEER CUIDADOSAMENTE**

WARNINGS

- 1. Read and understand all instructions.** Failure to follow all instructions may result in injury and / or damage.
- 2. Tighten all casters completely by using the wrench.** Failure to do as instructed could result in the caster stem breaking, thereby causing the product to collapse.
- 3. The warnings, cautions, and instructions discussed in this manual cannot cover all possible conditions or situations that may occur.** The user must always be aware of the environment and ensure to use the product in a safe and responsible manner.
- 4. Do NOT modify the product in any way.** Unauthorized modification may impair the function and / or safety of the product, and may affect the life of the product.
- 5. Check for damaged parts.** Before using this product, carefully check that all parts are in good condition, and that the product will operate properly and perform its intended function. Check for damaged parts and any other conditions that may affect the operation of this product. Replace damaged or worn parts, and never use this product with a damaged part.
- 6. Do NOT overload the product.**

Weight capacity per Shelf on Feet Levelers (evenly distributed)	453.5 kg / 1000 lb
Weight capacity per Shelf on Casters (evenly distributed)	60.3 kg / 133 lb
Total weight capacity of Shelving Rack (evenly distributed)	2721.5 kg / 6000 lb (on Feet Levelers) 362.8 kg / 800 lb (on Casters)

CARE AND MAINTENANCE

- Avoid harsh, abrasive cleaners, and other corrosive chemicals.
- This item is not certified for outdoor use.

PARTS LIST / LISTE DES PIÈCES / LISTA DE PARTES

Parts included
Pièces incluses
Piezas incluidas

A

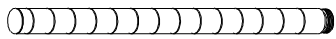

4

B

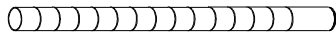

4

C

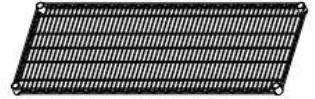

6

D



48 + 2

E

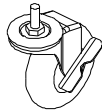

2

F



2

G



1

H



4

Used for Stationary option
Pour l'option fixe
Usado para la opción
Estacionaria

I



4

J



4

Used when making (2) 3-Tier Racks option
Pour réaliser 2 étagères à 3 tablettes
Usado cuando escoja la opción (2) Estante de 3 Repisas

K

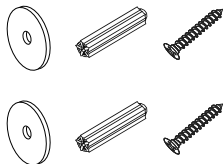

1

ASSEMBLY OPTIONS / OPTIONS D'ASSEMBLAGE / OPCIONES DE ENSAMBLE

Mobile Option / Option mobile / Opción Móvil

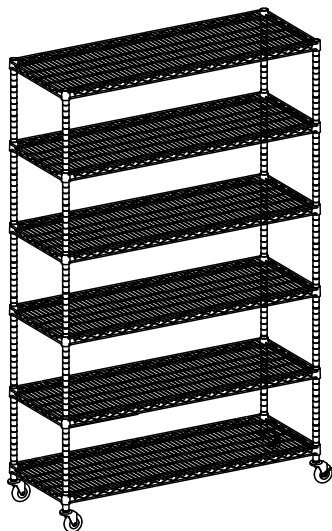
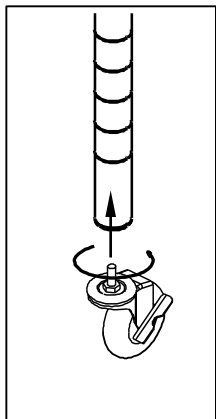

(2) 3-Tier Racks Option / 2 étagères à 3 tablettes / Opción (2) Estante de 3 Repisas

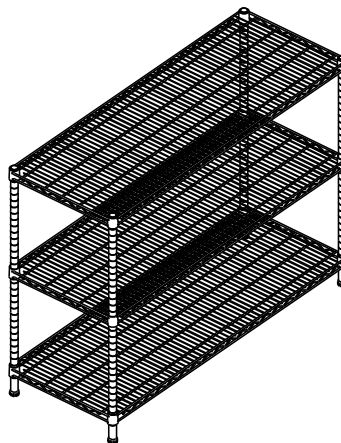

Stationary Option / Option fixe / Opción Estacionaria

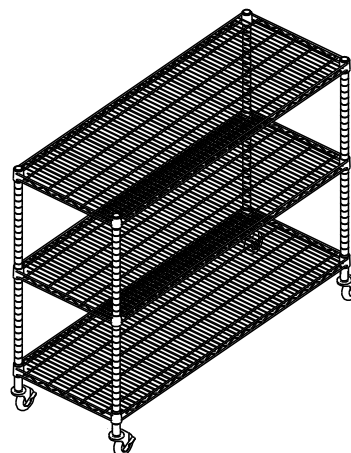
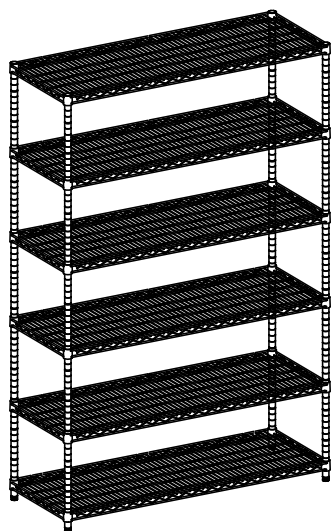
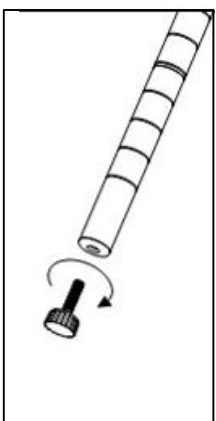

ASSEMBLY INSTRUCTIONS / DIRECTIVES D'ASSEMBLAGE / INSTRUCCIONES DE ENSAMBLE

STEP 1 ÉTAPE 1 PASO 1

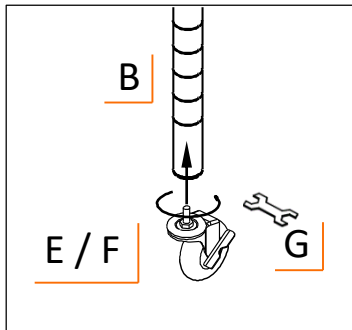
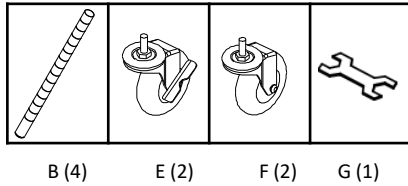

Warning: Tighten CASTERS (E & F) to BOTTOM POLES (B) completely. Failure to do as instructed could result in the caster stem breaking.

Mise en garde : Serrer fermement LES ROULETTES (E et F) aux TIGES INFÉRIEURES (B). Si les roulettes ne sont pas complètement serrées, les tiges des roulettes pourraient se briser.

Precaución: Ajuste las RUEDAS (E y F) a los POSTES INFERIORES (B) completamente. El no seguir las instrucciones podría resultar en que el vástago de las ruedas se rompa.

STEP 2 ÉTAPE 2 PASO 2

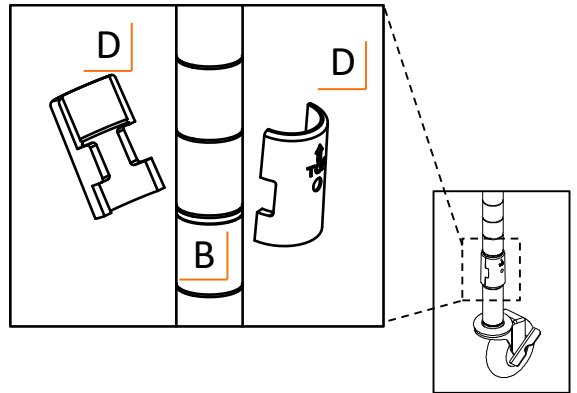

Note: For stability, the lowest SLIP SLEEVES (D) should be installed **no higher** than the 3rd indentation from the caster end of the BOTTOM POLES (B).

Remarque : Pour une meilleure stabilité, les MANCHONS À GLISSEMENT (D) les plus bas devraient être installés **au maximum** à la hauteur de la troisième encoche au-dessus de l'extrémité supérieure de la roulette des TIGES INFÉRIEURES (B).

Nota: Para estabilidad, las MANGAS DESLIZANTES (D) deben de ser instaladas **no más arriba** de la 3ra hendidura del extremo de la rueda de los POSTES INFERIORES (B).

ASSEMBLY INSTRUCTIONS / DIRECTIVES D'ASSEMBLAGE / INSTRUCCIONES DE ENSAMBLE

STEP 3 ÉTAPE 3 PASO 3

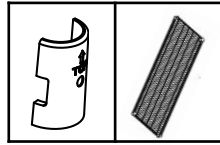

D (8) C (2)

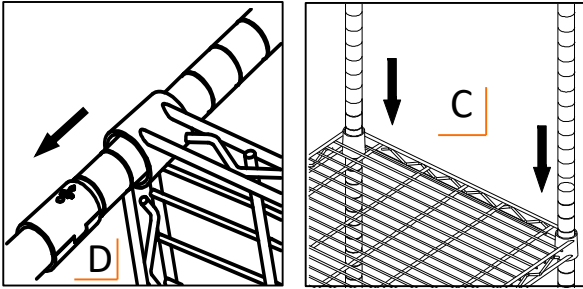

Note: The level side of the SHELF (C) is the TOP side (the TRINITY logo on the corner cylinders should be right-side up).

Remarque : Le côté plat de la TABLETTE (C) doit être orienté vers le HAUT (le logo TRINITY sur les cylindres dans les coins doit être à l'endroit).

Nota: El lado nivelado de la REPISA (C) es la PARTE DE ARRIBA (el logotipo de TRINITY en los cilindros de las esquinas deben de estar hacia arriba).

STEP 4 ÉTAPE 4 PASO 4

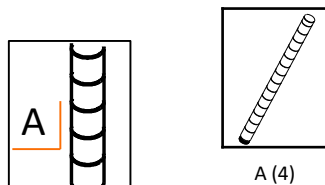

A (4)

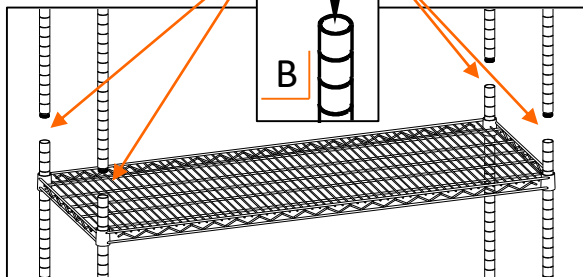

STEP 5 ÉTAPE 5 PASO 5

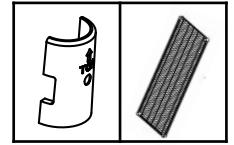

D (32) C (4)

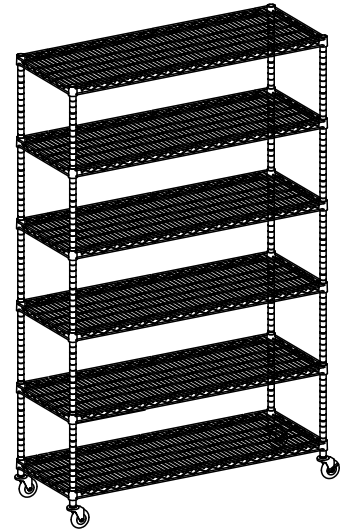
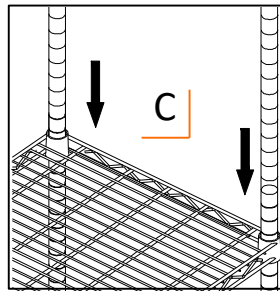
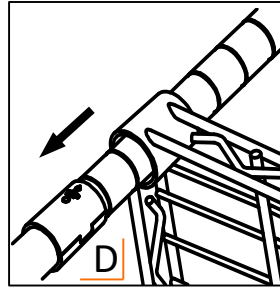

Stationary Option / Option fixe / Opción Estacionaria

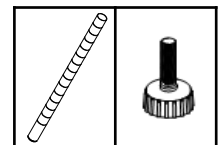

B (4) H (4)

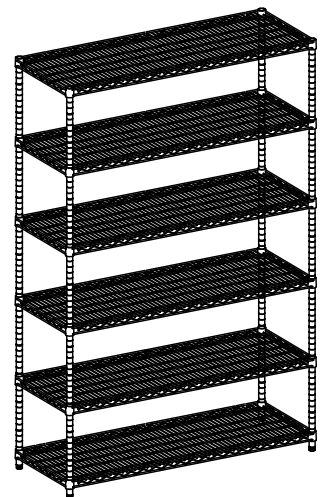
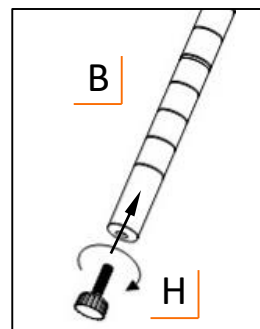

ASSEMBLY INSTRUCTIONS / DIRECTIVES D'ASSEMBLAGE / INSTRUCCIONES DE ENSAMBLE

Making (2) 3-Tier Racks Option /
 2 étagères à 3 tablettes /
 Haciendo la Opción (2) Estante de 3 Repisas

REPEAT STEP 1 - 3
 RÉPÉTER LES ÉTAPES 1 à 3
 REPITA PASO 1 - 3

STEP 4
 ÉTAPE 4
 PASO 4

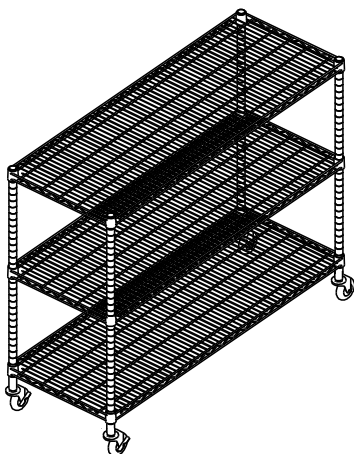
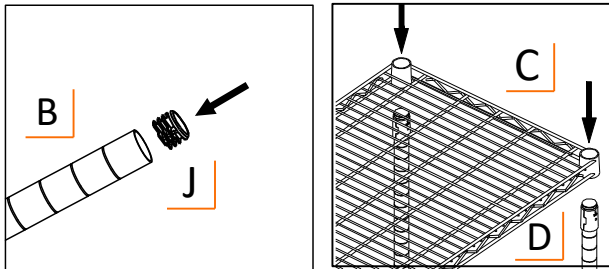
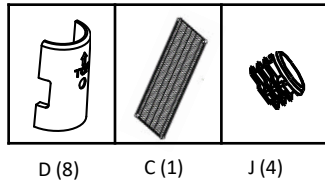

STEP 5
 ÉTAPE 5
 PASO 5

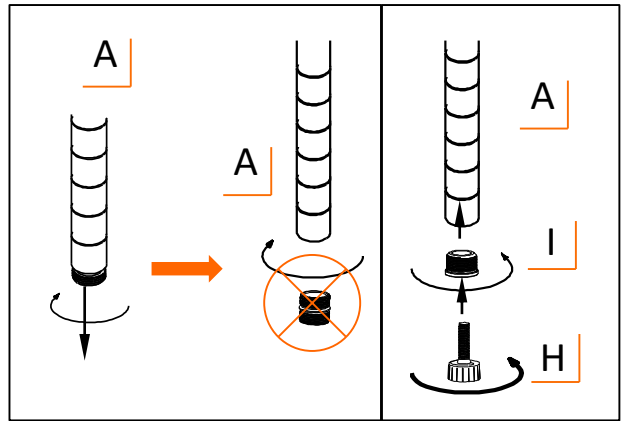
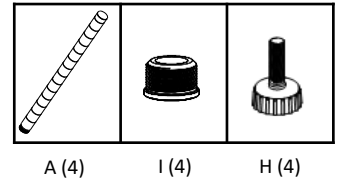

STEP 6
 ÉTAPE 6
 PASO 6

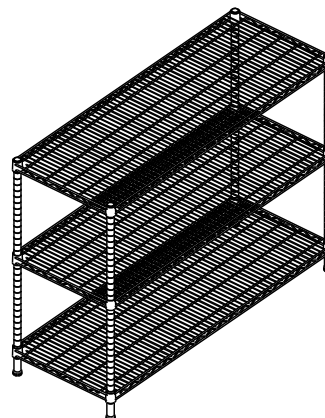
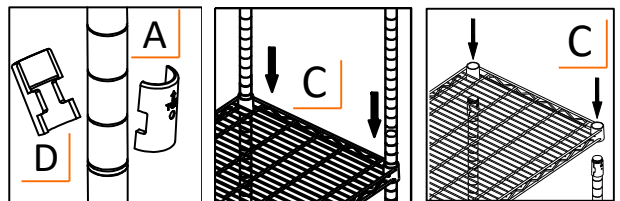
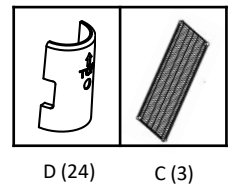

ASSEMBLY INSTRUCTIONS / DIRECTIVES D'ASSEMBLAGE / INSTRUCCIONES DE ENSAMBLE

Anti-tipping /
Anti-basculement
/ Anti-vuelco

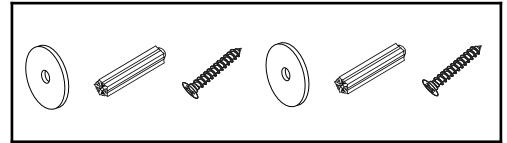

K (1)

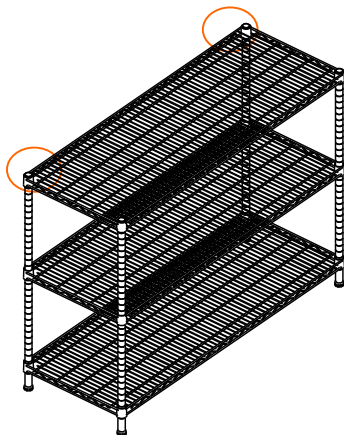
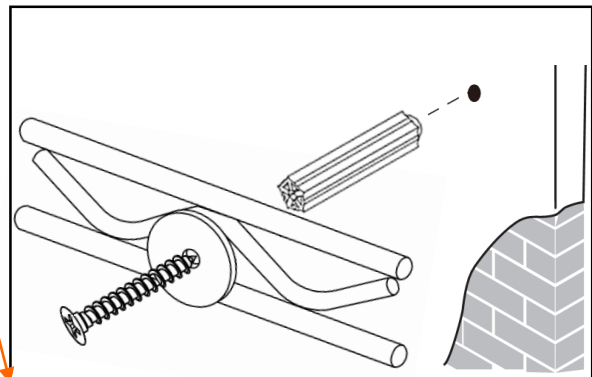
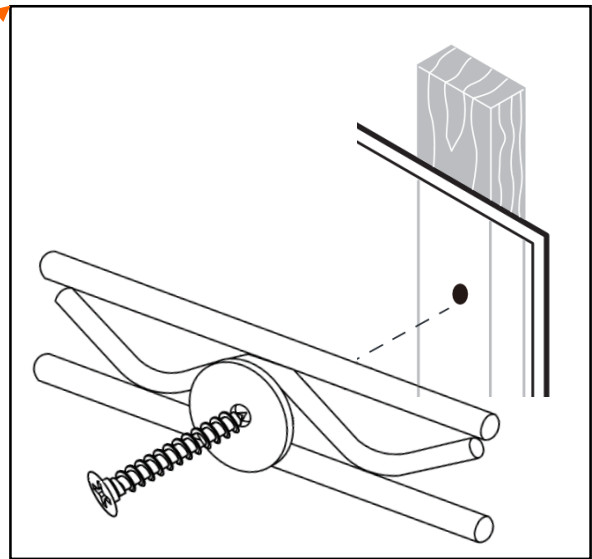
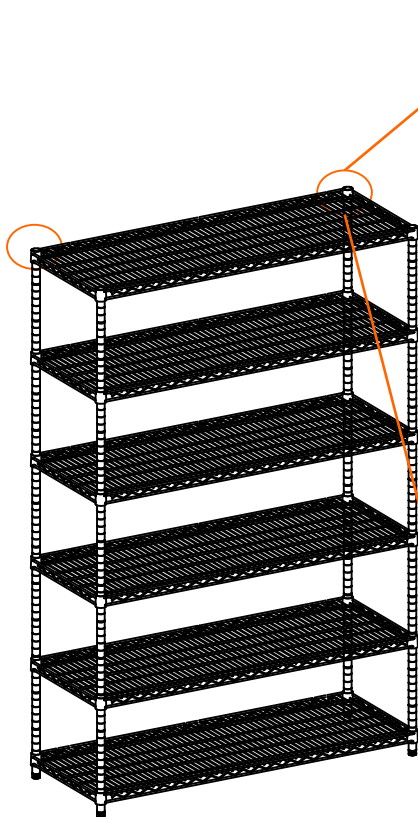

SERVICE PARTS LIST / LISTE DES PIÈCES DE RECHANGE / LISTA DE PARTES DE SERVICIO – CTBFZ-0945 / TBFZ-0945

	Part Number Numéro de produit Número de Parte	Part Number Numéro de produit Número de Parte	
A.	ZSV-04-006-3600	G.	XXX-97-002-0001
B.	ZSV-04-042-3600	H.	XBK-98-003-2538
C.	ZSV-03-050-4818	I.	ZSV-01-014-2513
D.	XBK-01-011-2543	J.	XBK-23-004-2517
E.	ZSV-99-008-4010	K.	ZSV-01-013-2523
F.	ZSV-99-007-4010	L.	ZSV-02-011-0001

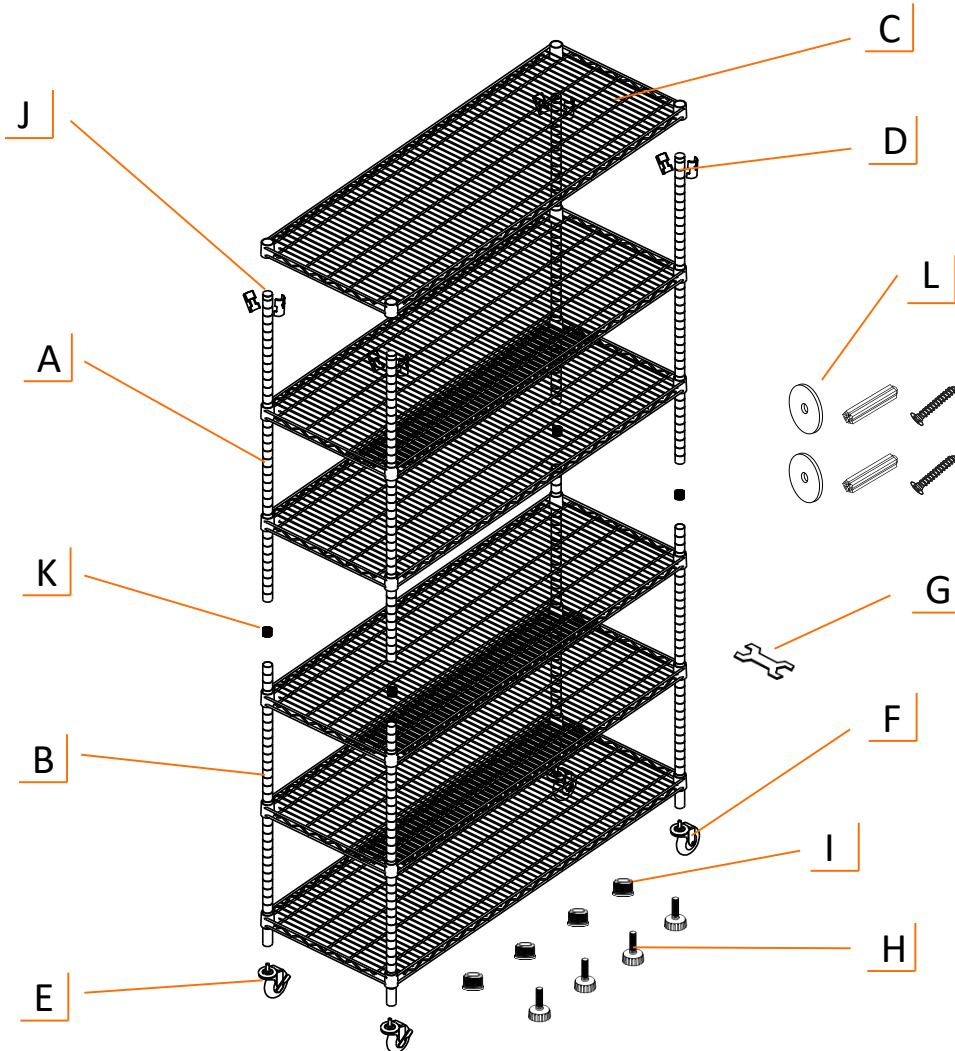

CONTACT US / NOUS JOINDRE / CONTÁCTENOS

MADE IN CHINA / FABRIQUÉ EN CHINE / HECHO EN CHINA

TRINITY Customer Service

(available only in Canada
and US)
(English, French, and Spanish)

TEL: 800.985.5506
FAX: 310.347.4134
customerservice@trinityii.com

Monday - Friday
8:00 AM – 5:00 PM (PST)

www.trinityii.com

TRINITY Service à la clientèle

(disponible seulement au Canada
et aux É.U.)
(anglais, français et espagnol)

TEL: 800.985.5506
FAX: 310.347.4134
customerservice@trinityii.com

Lundi au vendredi
8 h à 17 h (HNP)

www.trinityii.com

TRINITY Atención al cliente

(disponible sólo en Canadá
y E.U.A.)
(inglés, francés y español)

TEL: 800.985.5506
FAX: 310.347.4134
customerservice@trinityii.com

Lunes a viernes
8:00 A. M. a 5:00 P. M. (PST)

www.trinityii.com

Distributed by:
Costco Wholesale Corporation
P.O. Box 34535
Seattle, WA 98124-1535
USA
1-800-774-2678
www.costco.com

Imported by / Importé par :
Costco Wholesale Canada Ltd.*
415 W. Hunt Club Road
Ottawa, Ontario
K2E 1C5, Canada
1-800-463-3783
www.costco.ca
* faisant affaire au Québec sous le nom Les Entrepôts Costco

Importado por:
Importadora Primex S.A. de C.V.
Blvd. Magnocentro No. 4
San Fernando La Herradura
Huixquilucan, Estado de México
C.P. 52765
RFC: IPR-930907-S70
(55)-5246-5500
www.costco.com.mx

Imported by:
Costco Wholesale Australia Pty Ltd
17-21 Parramatta Road
Lidcombe NSW 2141
Australia
www.costco.com.au

Imported by:
Costco Wholesale UK Ltd /
Costco Online UK Ltd
Hartspring Lane
Watford, Herts
WD25 8JS
United Kingdom
01923 213113
www.costco.co.uk

Importado por:
Costco Wholesale Spain S.L.U.
Poligono Empresarial Los Gavilanes
C/ Agustín de Betancourt, 17
28906 Getafe (Madrid) España
NIF: B86509460
900 111 155
www.costco.es

Distributed by:
Costco Wholesale Iceland ehf.
Kaupún 3-7, 210 Gardabaer
Iceland
www.costco.is

Distribué par :
Costco France
11 avenue de Bréhat
91140 Villebon-sur-Yvette
France
01 80 45 01 10
www.costco.fr

Imported by:
Costco Wholesale Japan Ltd.
3-1-4 Ikegami-Shincho
Kawasaki-ku, Kawasaki-shi,
Kanagawa 210-0832 Japan
044-281-2600
www.costco.co.jp

Imported and Distributed by:
Costco Wholesale Korea, Ltd.
40, Iljik-ro
Gwangmyeong-si
Gyeonggi-do, 14347, Korea
1899-9900
www.costco.co.kr

Imported by / Manufactured for:
Costco President Taiwan, Inc.
No. 656 Chung-Hwa 5th Road
Kaohsiung, Taiwan
Company Tax ID: 96972798
449-9909 or 02-449-9909 (if cellphone)
www.costco.com.tw

Imported by / Distributed by:
Costco (Shanghai) Trading Co., Ltd.
Room 2105, No. 2299 Yanan West Road
Changning District, Shanghai, China
+86-21-62577065