

3.7m x 4.3m (12.1' x 14.1') GRAND GAZEBO with ALUMINUM ROOF

Installation and Operating Instructions – YM12978



IMPORTANT, RETAIN FOR FUTURE REFERENCE: READ CAREFULLY

08-26-2021

YARDISTRY®

Yardistry – North America
Toll Free Customer Support:
1.888.509.4382
info@yardistrystructures.com
www.yardistrystructures.com

Regular Hours: Mon - Fri, 8:30 am - 5:00
pm EST (excl. holidays)
(For extended hours see our website)
English and French Spoken

Patents Pending

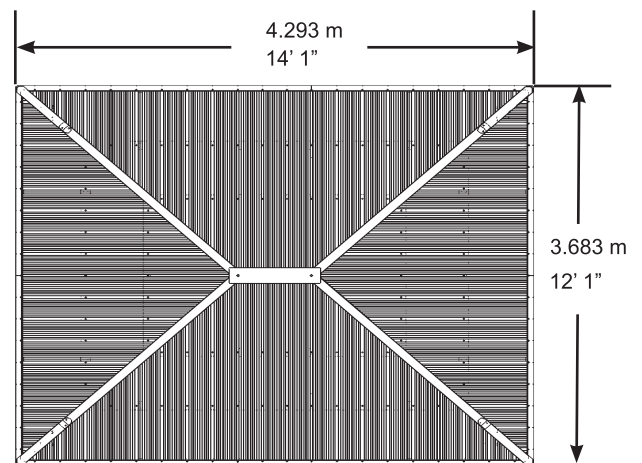

HEIGHT:
3.175m / 10'5"

Important Safety Notice!

Yardistry components are intended for privacy, decorative and ornamental use only.

Product is NOT INTENDED for the following:

- A safety barrier to prevent unsupervised access to pools, hot tubs, spas or ponds.
- As load bearing support for a building, structure, heavy objects or swings.
- Used in structures that trap wind, rain or snow that would create extra load on the product.

Accumulated snow must be removed from roof.

DO NOT climb or walk on roof for any reason.

Permanent structures may require a building permit. As the purchaser and or installer of this product you are advised to consult local planning, zoning and building inspection departments for guidance on applicable building codes and/or zoning requirements.

Wood is NOT flame retardant and will burn. Grills, fire pits and chimineas are a fire hazard if placed too close to a Yardistry structure. Consult user's manual of the grill, fire pit or chiminea for safe distances from combustible materials.

Wear gloves to avoid injury from possible sharp edges of individual elements before assembly.

During installation, follow all safety warnings provided with your tools and use OSHA approved safety glasses. Some structures may require two or more people to install safely.

Check for underground utilities before digging or driving stakes into the ground!

During assembly it is important to closely follow the instructions. Complete the assembly on a solid, level surface and follow the instructions to square up, level and anchor the structure. This will reduce the gaps at wood connections during assembly.

General Information

General Information: Wood components are manufactured with Cedar (C. Lanceolata) which is protected with factory applied water-based stain. Knots, small checks (cracks) and weathering are naturally occurring and do not affect the strength of the product. Annual application of a water-based water repellent sealant or stain is important and will help reduce weathering and checks.

www.yardistrystructures.com

Questions?

Call toll free or write us at:
1 (888) 509-4382
support@yardistrystructures.com

Regular Hours: Mon - Fri, 8:30 am - 5:00 pm EST
(excl. holidays)
(For extended hours see our website)

English and French Spoken

Patents Pending

Limited Warranty

Yardistry warrants that this product is free from defect in materials and workmanship for a period of one (1) year from the original date of purchase. In addition, for any product with lumber, all lumber is warranted for five (5) years against rot and decay. This warranty applies to the original owner and registrant and is non-transferable.

Regular maintenance is required to assure the integrity of your product and is a requirement of the warranty. This warranty does not cover any inspection costs.

This Limited Warranty does not cover:

- Labour for replacement of any defective item(s);
- Incidental or consequential damages;
- Cosmetic defects which do not affect performance or integrity;
- Vandalism; improper use or installation; acts of nature, including but not limited to wind, storms, hail, floods, excessive water exposure;
- Minor twisting, warping, checking or any other natural occurring properties of wood that do not affect performance or integrity.

Yardistry products have been designed for safety and quality. Any modifications made to the original product could damage the structural integrity of the product leading to failure and possible injury. Yardistry cannot assume any responsibility for modified products. Furthermore, modification voids any and all warranties.

This product is warranted for RESIDENTIAL USE ONLY. Yardistry disclaims all other representations and warranties of any kind, express or implied.

This Warranty gives you specific legal rights. You may have other rights as well which vary from state to state or province to province. This warranty excludes all consequential damages, however, some states/provinces do not allow the limitation or exclusion of consequential damages, and therefore this limitation may not apply to you.

Instructions for Proper Maintenance

Your Yardistry structure is designed and constructed of quality materials. As with all outdoor products it will weather and wear. To maximize the enjoyment, safety and life of your structure it is important that you, the owner, properly maintain it.

HARDWARE:

- Check metal parts for rust. If found, sand and repaint using a non-lead paint complying with 16 CFR 1303.
- Inspect and tighten all hardware after completion of assembly; after first month of use; and then annually. Do not over-tighten as to cause crushing and splintering of wood.
- Check for sharp edges or protruding screw threads, add washers if required.

WOOD PARTS:

- Applying a water repellent or stain (water-based) on a yearly basis is important maintenance to maintain maximum life and performance of the product.
- Check all wood members for deterioration, structural damage and splintering. Sand down splinters and replace deteriorated wood members. As with all wood, some checking and small cracks in grain is normal.
- Some gapping may occur at some wood connections.

Assembly Guides

Tools Required:

- | | | |
|------------------------------|------------------|---------------------------|
| • Tape Measure | • 8' Step Ladder | • 6' Step Ladder x 2 |
| • Carpenters Level | • Safety Glasses | • Square |
| • Standard or Cordless Drill | • Adult Helper | • Ratchet |
| • Claw Hammer | • Safety Gloves | • 7/16, 1/2 & 9/16 Socket |
| • 7/16" & 9/16" Wrench | • Hard Hat | |

Symbols:

Throughout these instructions symbols are provided in the top, right-hand corner of the page.



- Use Help, where this is shown, 2, 3 or 4 people are required to safely complete this step. To avoid injury or damage to the assembly make sure to get some help.



- Use a measuring tape to assure proper location



- Pre-drill a pilot hole before fastening screw or lag to prevent splitting of wood.

If you dispose of your Yardistry structure: Please disassemble and dispose of your unit so that it does not create any unreasonable hazards at the time it is discarded. Be sure to follow your local waste ordinances.

Assembly Tips

Following are some helpful tips to make the assembly process smooth and efficient.

PRE-ASSEMBLIES:

(i.e. Post and Beam Assemblies, Roof Rafter Assembly, etc)

- Work on a raised, solid and flat surface such as, a table or saw horse.
- Keep all connections flush where shown in the instructions.
- When assembling the beams keep parts flat, straight and snug when connecting.

METAL PARTS:

- Roofing material may have sharp edges, wear safety gloves.
- Remove all plastic covering, on both sides of the metal panels, directly before installing each piece.
- Place roofing material on a non-abrasive surface before and after assembly as it can bend, dent and scratch easily.
- The roofing screws can easily crush the roof panels and roof edges when using a power drill. We recommend hand tightening the roofing screws so they sit snug and tight to the roofing material.

Permanent Installation Examples

Note: It is critically important you start with square, solid and level footings, concrete pad or deck to attach your Pergola Room.

We supply Post Mounts with this structure which gives you the flexibility to permanently install your structure to a pre-existing or new wood or concrete surface.

- The hardware to attach the Post Mount to the structure is included.
- The hardware to mount the structure permanently will need to be purchased separately at your local hardware store.

If you are mounting to concrete footers see below for the correct locations and placement. Please double check for possibility of any underground utilities such as gas, telephone, cable or sprinkler lines.

Following are some examples of how to mount the structure to wood or concrete surfaces.

Refer to your local building and city codes, ordinances, neighbourhood covenants, or height restrictions regarding this type of structure for guidance on acceptable installation requirements.

Concrete Footer

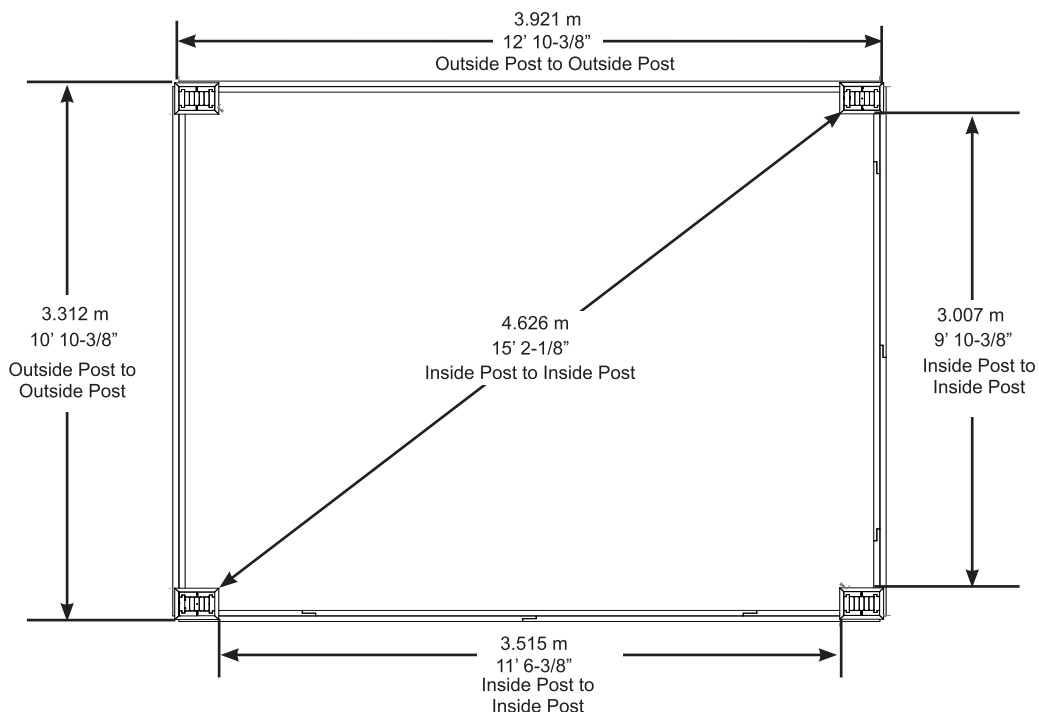
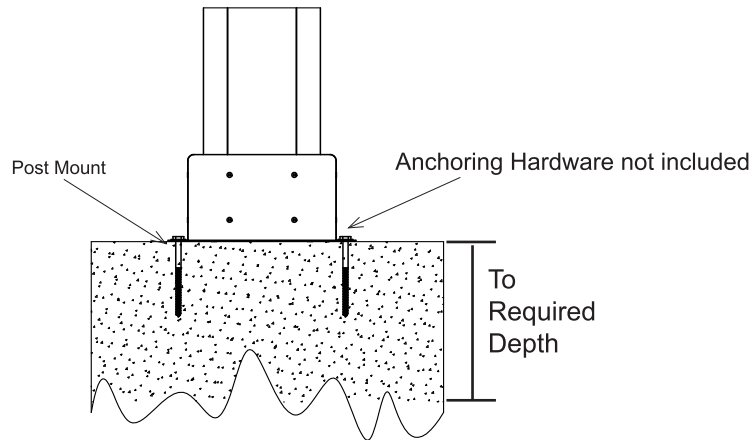

Permanent Installation Examples cont.

**Concrete Patio [min. 3.616 m x 4.226 m (11'10-3/8" x 13'10-3/8")]
with 15.24 cm (6") clearance on all sides**

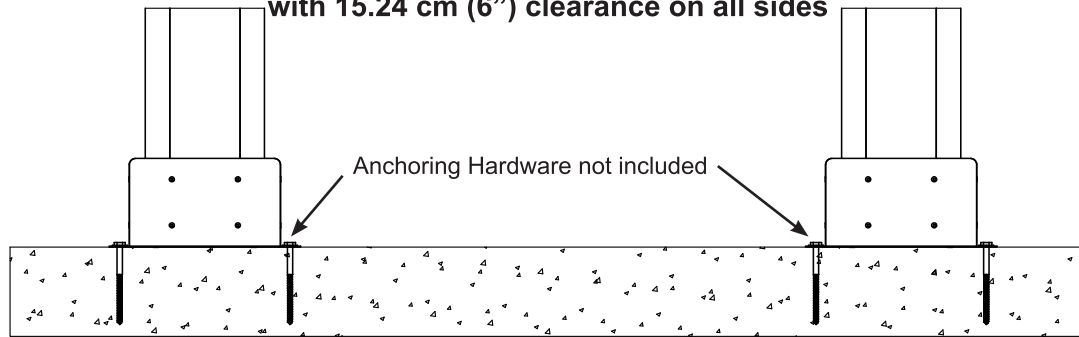

**Wood Deck [min. 3.616 m x 4.226 m (11'10-3/8" x 13'10-3/8")]
with 15.24 cm (6") clearance on all sides**

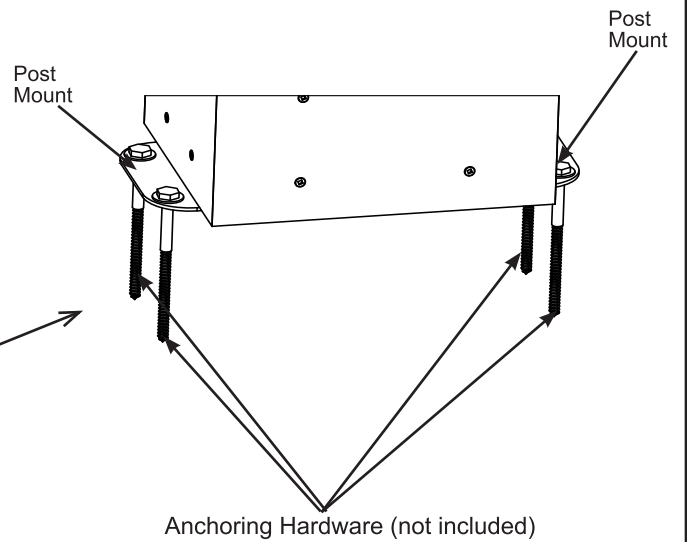
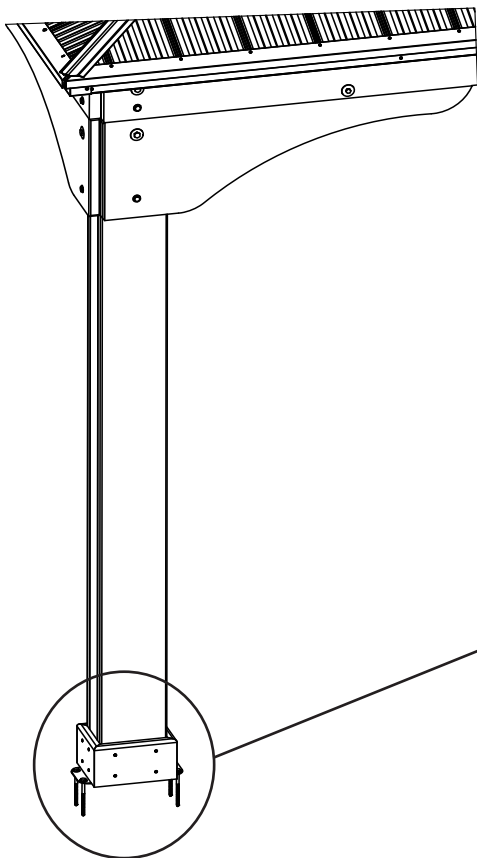
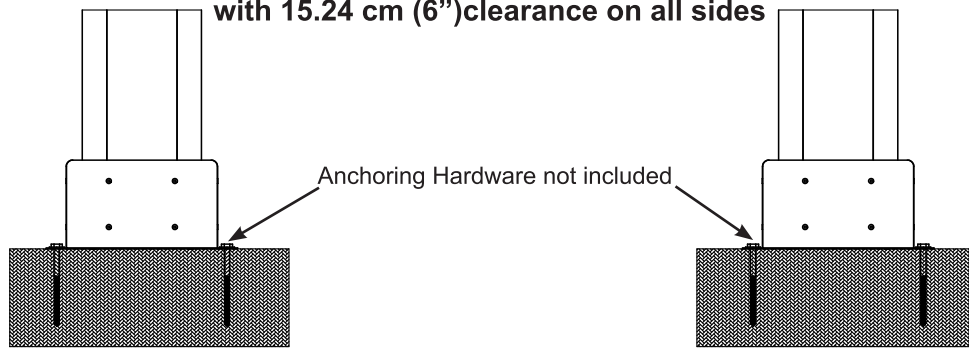

Post Mounts have a 1.27 cm (1/2") diameter hole for anchoring hardware.

Part Identification (Dimensions are approximate and are shown to assist in the identification of parts for assembly. Actual dimensions may be smaller or larger.)

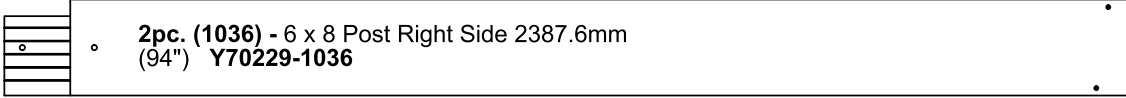

2pc. (1036) - 6 x 8 Post Right Side 2387.6mm
(94") Y70229-1036

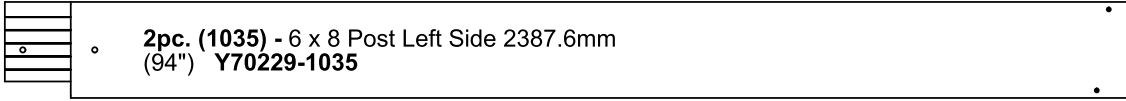

2pc. (1035) - 6 x 8 Post Left Side 2387.6mm
(94") Y70229-1035

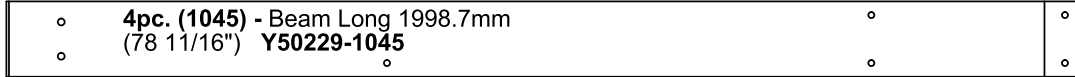

4pc. (1045) - Beam Long 1998.7mm
(78 11/16") Y50229-1045



2pc. (1046) - Long Beam Centre 2587.5mm (101 7/8") Y50229-1046

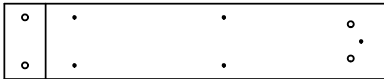

4pc. (1047) - Beam Long End 706.5mm (27 13/16") Y50229-1047

2pc. (1042) - Short Beam Centre 2422.1mm (95 3/8") Y50229-1042

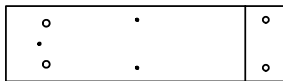

4pc. (1043) - Beam Short End 519.4mm (20 7/16") Y50229-1043

2pc. (434) - Top 577.9mm (22 3/4") Y50229-434

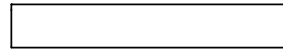

4pc. (1044) - Beam Short 1693.9mm (66 11/16") Y50229-1044

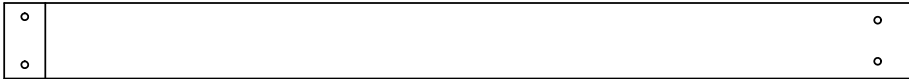

8pc. (1048) - Plinth Long 250.8mm (9 7/8") Y50229-1048

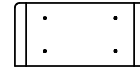

2pc. (443) - Fascia Left 1853mm (72 -15/16") Y50229-443



2pc. (444) - Fascia Right 1853mm (72 -15/16") Y50229-444

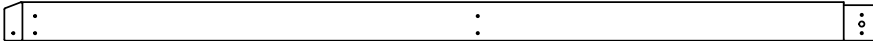

8pc. (459) - Plinth 200mm (7 7/8") Y50229-459

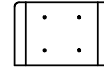

2pc. (435) - Fascia Left - Large Roof 2157.7mm (84 -15/16") Y50229-435



2pc. (436) - Fascia Right - Large Roof 2157.7mm (84 -15/16") Y50229-436

4pc. (441) - Rafter Short Left 1040.2mm (40 15/16") Y50229-441

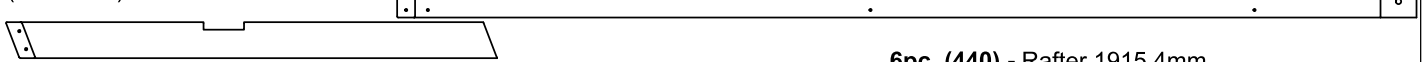

6pc. (440) - Rafter 1915.4mm (75 7/16") Y50229-440

4pc. (442) - Rafter Short Right 1040.2mm (40 15/16") Y50229-442

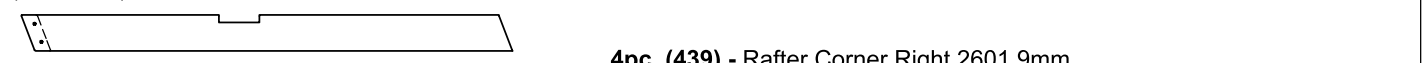

4pc. (439) - Rafter Corner Right 2601.9mm (102 7/16") Y50229-439



4pc. (438) - Rafter Corner Left 2601.9mm (102 7/16") Y50229-438

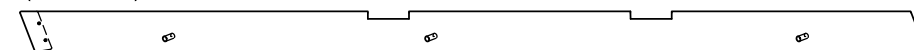

Part Identification (Dimensions are approximate and are shown to assist in the identification of parts for assembly. Actual dimensions may be smaller or larger.)

2pc. (337) - Strap Short 1561.3mm
(61 1/2") **Y50229-337**

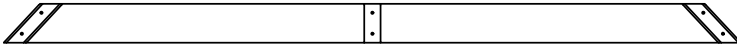

2pc. (433) - Strap Brace 574.7mm
(22 5/8") **Y50229-433**

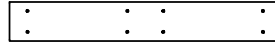

2pc. (430) - Strap Short - Large Roof 2170.9mm
(85 1/2") **Y50229-430**

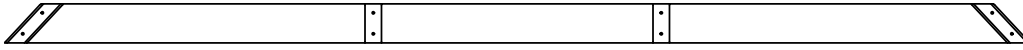

2pc. (437) - Strap 2603.5mm
(102 1/2") **Y50229-437**

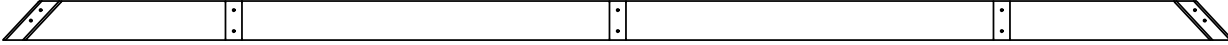

2pc. (432) - Strap Right - Large Roof 1605.6mm
(63 3/16") **Y50229-432**

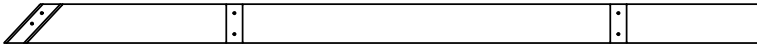

2pc. (431) - Strap Left - Large Roof 1605.6mm
(63 3/16") **Y50229-431**

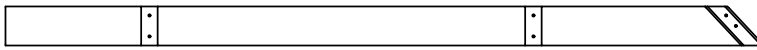

2pc. (461) - Tie 2336.8mm
(92") **Y50229-461**

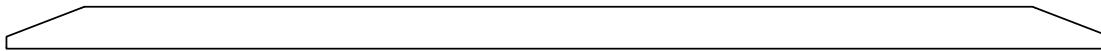

4pc. (1049) - Arched Gusset 1117.6mm
(44") **Y70229-1049**

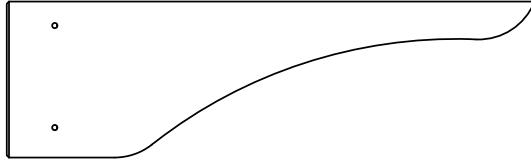

4pc. (1053) - Arched Gusset Short 1066.8mm
(42") **Y70229-1053**

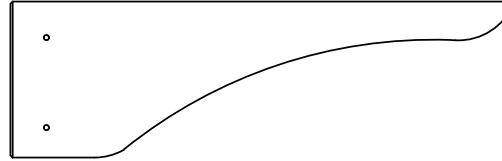

1pc. (463) - Spacer Top 574.7mm
(22 5/8") **Y50229-463**



Hardware Identification (Dimensions are approximate and are shown to assist in the identification of parts for assembly. Actual dimensions may be smaller or larger.)

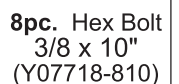
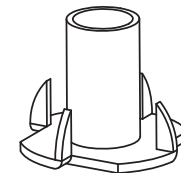
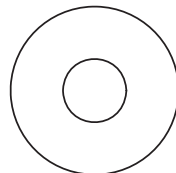
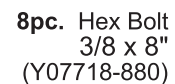
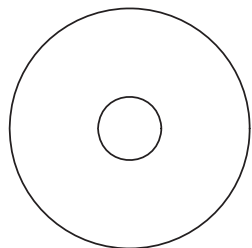
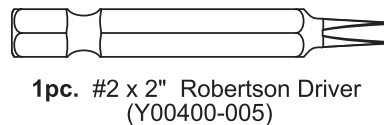
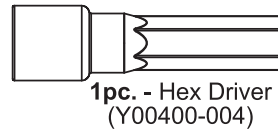
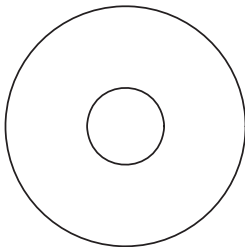
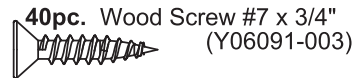
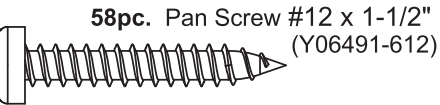
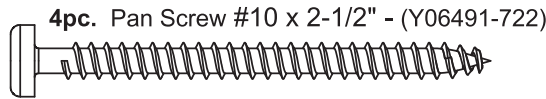
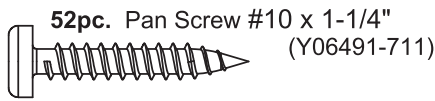
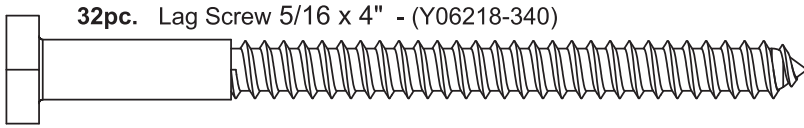
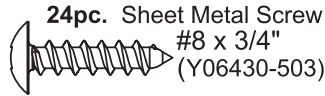
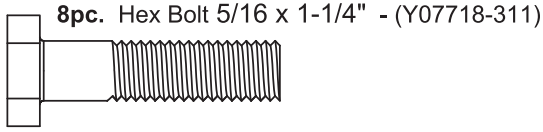
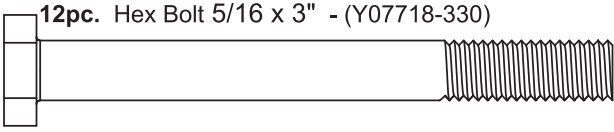
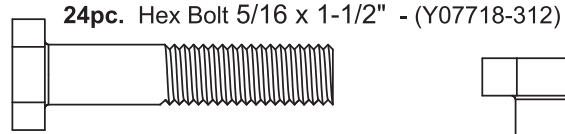
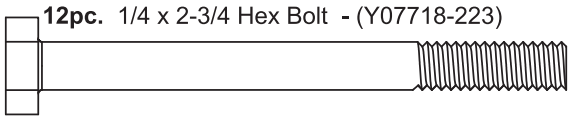

Hardware Identification (Dimensions are approximate and are shown to assist in the identification of parts for assembly. Actual dimensions may be smaller or larger.)

4pc. - Short Panel Left (Y01037-126)

4pc. - Long Panel Left (Y01037-127)

2pc. - Middle Panel (Y01037-130)

4pc. - Long Panel Right (Y01037-129)

4pc. - Short Panel Right (Y01037-128)

4pc. - Ridge Cap Short 25.2 (Y01030-132)

4pc. - Ridge Cap Long 81.5 (Y01030-131)

1pc. - Roof Panel Set (Y070837-138)

4pc. Roof Edge Left 72.2 - (Y01030-134)

2pc. Roof Edge Right 72.2 - (Y01030-135)

2pc. Roof Edge Right 96.2 - (Y01030-136)

8pc. Ridge Clip 102.5 - (Y01030-133)

2pc. Long Beam Insert - (Y00429-124)

1pc. Tie Wrap Bracket (4Pk) (Y70829-106)

1pc. Peak Cap Long (Y01030-137)

2pc. Peak Post (Y01000-094)

1pc. (2 Pk) 45° Twist Bracket LT (Y70829-191)

1pc. (2 Pk) 45° Twist Bracket RT (Y70829-192)

1pc. - Weather Seal - Ridge Clip (8Pk) (Y70818-074)

1pc. - Corner Cap Set (4Pk) (Y70830-103)

1pc. - Roof To Beam Bracket Set (14Pk) (Y70829-123)

1pc. - Gazebo ID Plaque (Y70800-104)

2pc. - 50mm Hook (Y00418-050)

1pc. - Rafter To Post Bracket Set (4Pk) (Y70829-350)

1pc. - Post Mount Set (8Pk) (Y70819-109)

2pc. Carriage Bolt (Y07428-260)

2pc. Spring Clip (Y09490-001)

1pc. 1/4" Eye Lag (Y00218-001)

4pc. Roof Peak Bracket (Y00429-125)

2pc. 1/4" Nut (Y08490-200)

2pc. Peak Loop (Y20018-003)

2pc. Contoured Washer (Y05918-211)

1pc. - Roof Peak Set (Y70829-125)

Step 1: Inventory Parts - Read This Before Starting Assembly

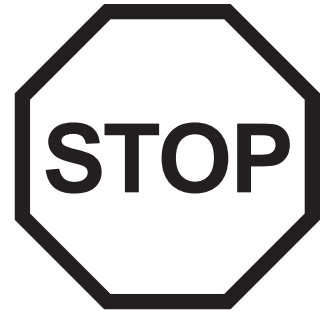
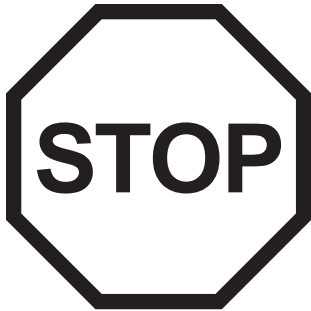

- A.** This is the time for you to inventory all your hardware, wood and accessories, referencing the parts identification sheets. This will assist you with your assembly.
- Each step indicates which bolts and/or screws you will need for assembly, as well as any flat washers, lock washers, t-nuts or lock nuts.
- B.** If there are any missing or damaged pieces or you need assistance with assembly please contact the consumer relations department directly. Call us before going back to the store.

1-888-509-4382
support@yardistrystructures.com

- C.** Read the assembly manual completely, paying special attention to ANSI warnings; notes; and safety/maintenance information on pages 1 - 4.
- Follow the instructions in order.
 - This structure is designed to be assembled and installed ideally by four people, DO NOT attempt to install alone.
 - Consider the slope of elevation where you plan to install the structure. Also, check for gas, telephone, other utilities or sprinkler line locations prior to excavating any holes.
- D.** Before you discard your cartons fill out the form below.
- The carton I.D. stamp is located on the end of each carton.
 - Please retain this information for future reference. You will need this information if you contact the Consumer Relations Department.

PRODUCT NUMBER: YM12978

CARTON I.D. STAMP: _ _ _ _ _ (Box 1)

CARTON I.D. STAMP: _ _ _ _ _ (Box 2)

CARTON I.D. STAMP: _ _ _ _ _ (Box 3)

Step 2: Post Assemblies

Part 1

A: At the bottom of one (1035) 6 x 8 Post Left Side insert one 5/16" T-Nut on the outside of each short side. (F2.1 and F2.2)

B: At the bottom of the same post place two Post Mounts tight to the bottom and inside faces on the short sides as shown in F2.1 and F2.2. Loosely attach with one 5/16 x 1-1/4" Hex Bolt (with 5/16" lock washer and 1/4-5/16" large washer) per mount so they connect to the T-Nuts. From the bottom attach with two #8 x 1-1/2" Wood Screws and from the inside with two #10 x 1-1/4" Pan Screws per mount. Tighten bolts.

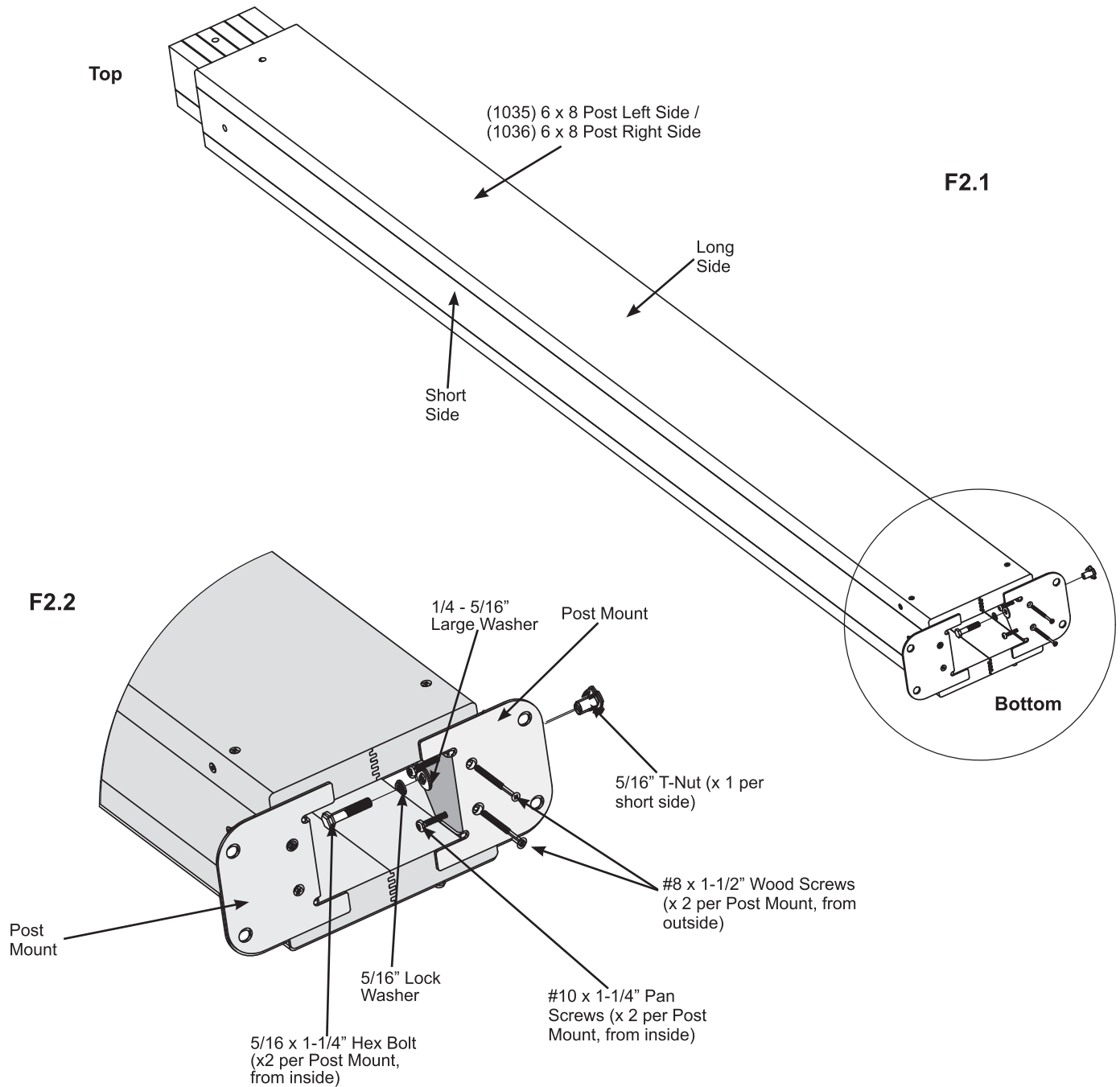

Wood Parts

- 2 x (1035) 6 x 8 Post Left Side
- 2 x (1036) 6 x 8 Post Right Side

Components:

- 8 x Post Mount

Hardware

- 16 x #8 x 1-1/2" Wood Screw
- 16 x #10 x 1-1/4" Pan Screw
- 8 x 5/16 x 1-1/4" Hex Bolt
(with 5/16" lock washer, 1/4 - 5/16" large washer, 5/16" t-nut)

Step 2: Post Assemblies Part 2

C: Flush to the bottom of (1035) 6 x 8 Post Left Side place one (1048) Plinth Long on each long side and one (459) Plinth on each short side then attach with four #8 x 1-1/2" Wood Screws per plinth. Rounded edges on top. (F2.3 and F2.4)

D: Repeat Steps A - C one more time to make two Post Left Assemblies.

E: Repeat Steps A - C twice more using (1036) 6 x 8 Post Right Sides to make two Post Right Assemblies.

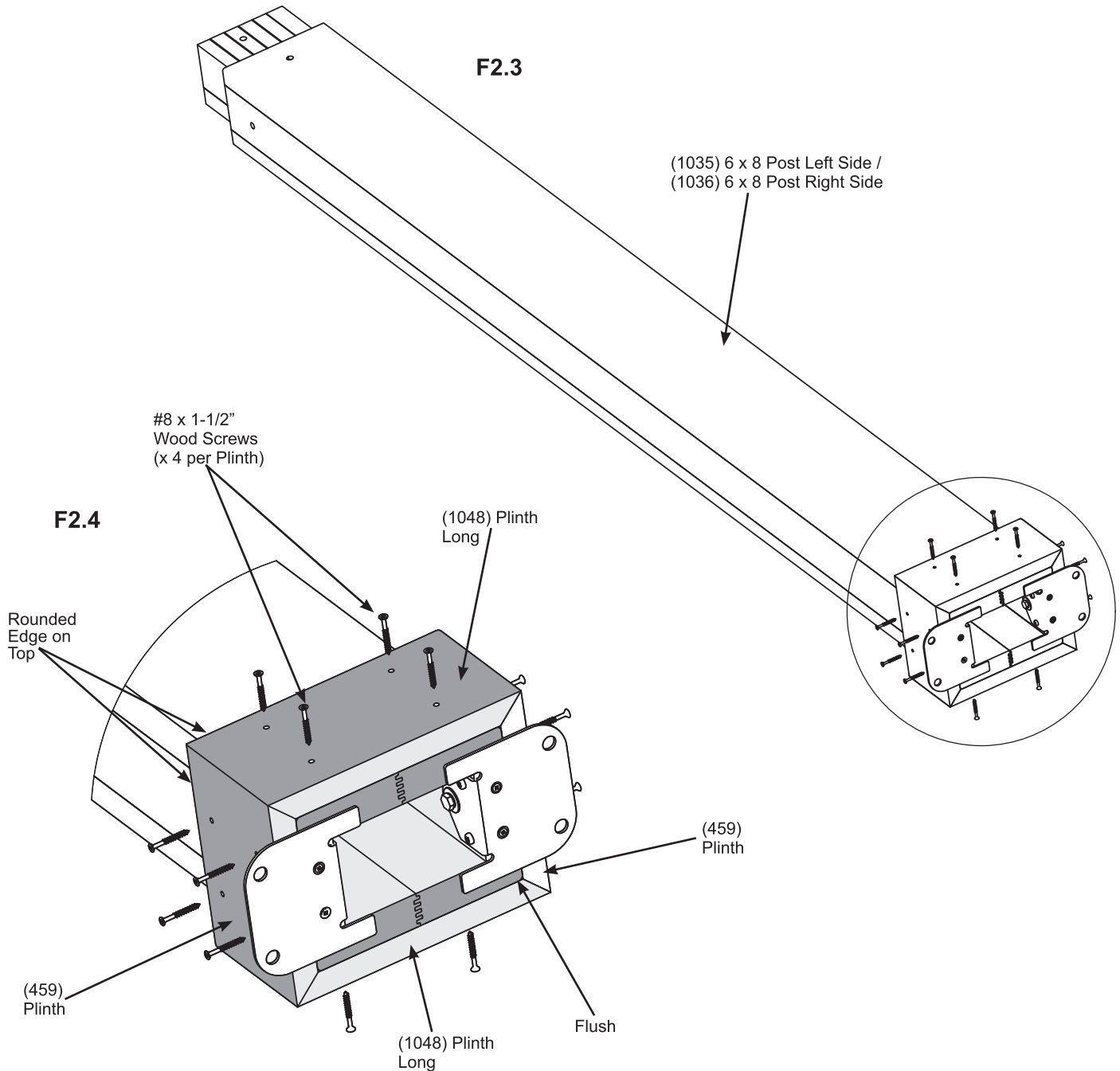

Wood Parts

8 x (459) Plinth
8 x (1048) Plinth Long

Hardware

64 x #8 x 1-1/2" Wood Screw

Step 3: Short Beam Assembly Part 1

A: Connect two (1044) Beam Shorts using two 5/16 x 1-1/2" Hex Bolts (with 5/16" lock washer, 1/4-5/16" large washer and 5/16" t-nut) as shown in F3.1 and F3.2.

B: Connect one (1043) Beam Short End to each end of one (1042) Short Beam Centre using two 5/16 x 1-1/2" Hex Bolts (with 5/16" lock washer, 1/4-5/16" large washer and 5/16" t-nut) per end as shown in fig. 3.1 and 3.2.

C: Repeat Steps A and B one more time to make two Beam Short Assemblies and two Short Beam End Assemblies.

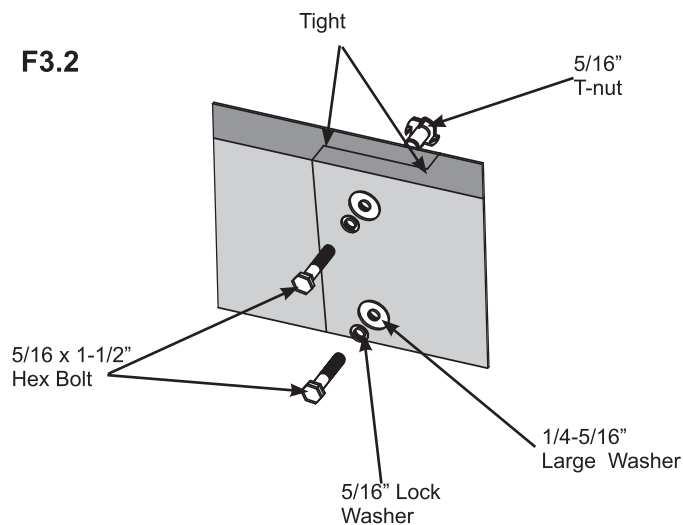
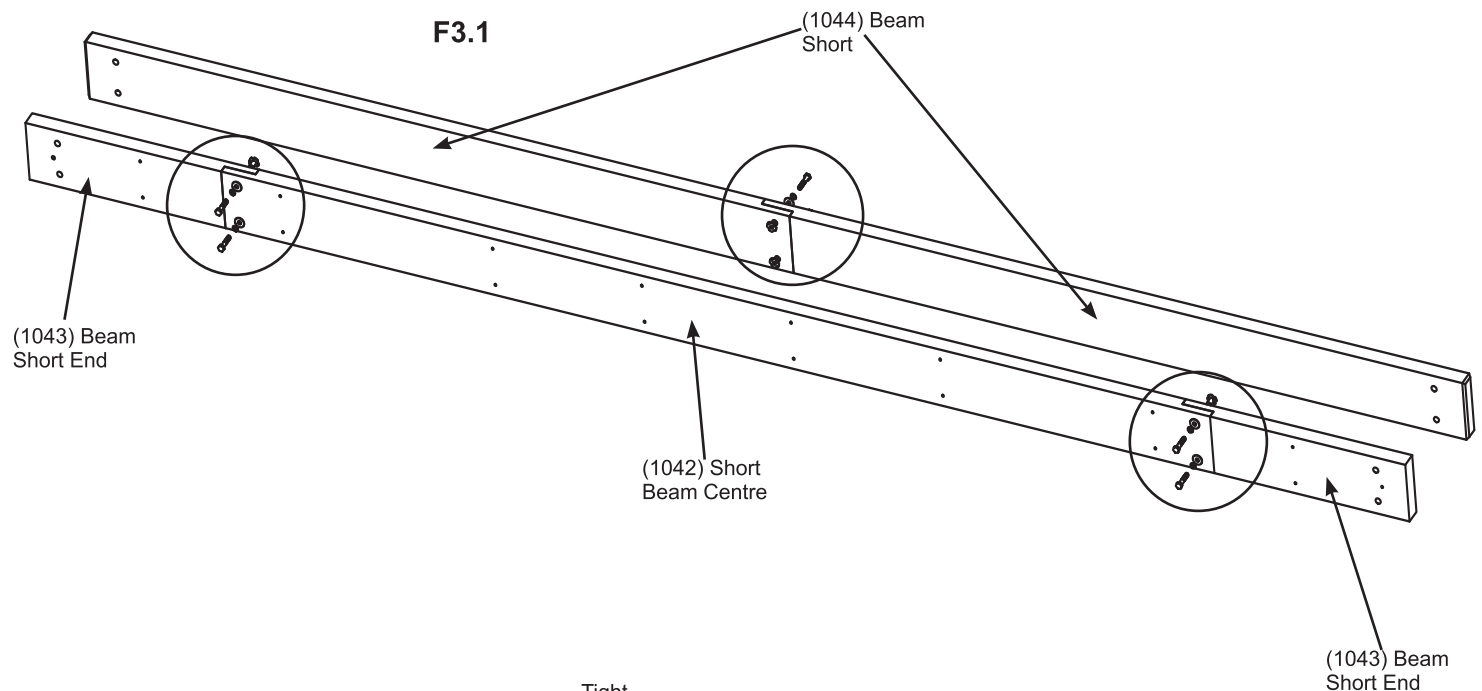

Make sure bolt heads are on the outside of each Beam Assembly

Wood Parts

- 4 x (1043) Beam Short End
- 2 x (1042) Short Beam Centre
- 4 x (1044) Beam Short

Hardware

- 12 x 5/16 x 1-1/2" Hex Bolt
(5/16" lock washer, 1/4-5/16" large washer, 5/16" t-nut)

Step 3: Short Beam Assembly Part 2

D: Place one Beam Short Assembly tight to one Short Beam End Assembly. Match the bolt holes in each (1043) Beam Short End with the bolt holes in each (1044) Beam Short. Attach with 18 #8 x 2-1/2" Wood Screws. (F3.3 and F3.4)

E: Repeat Step D one more time to make two Short Beam Assemblies.

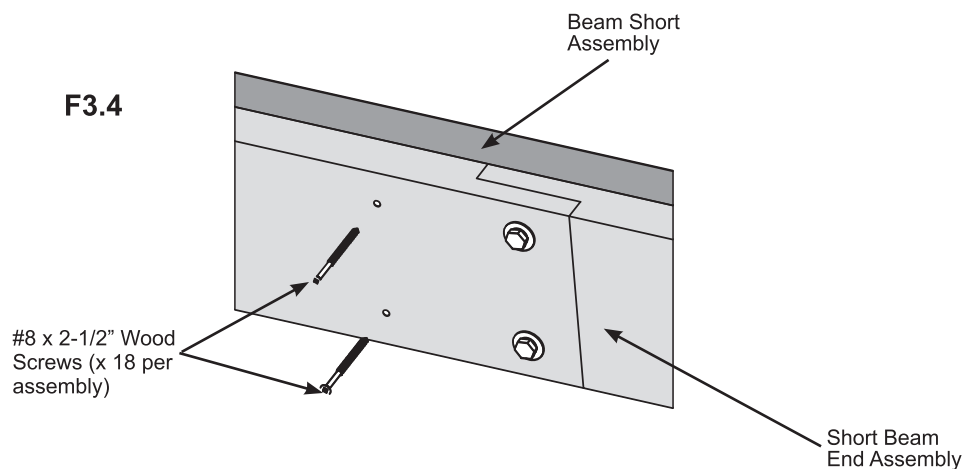
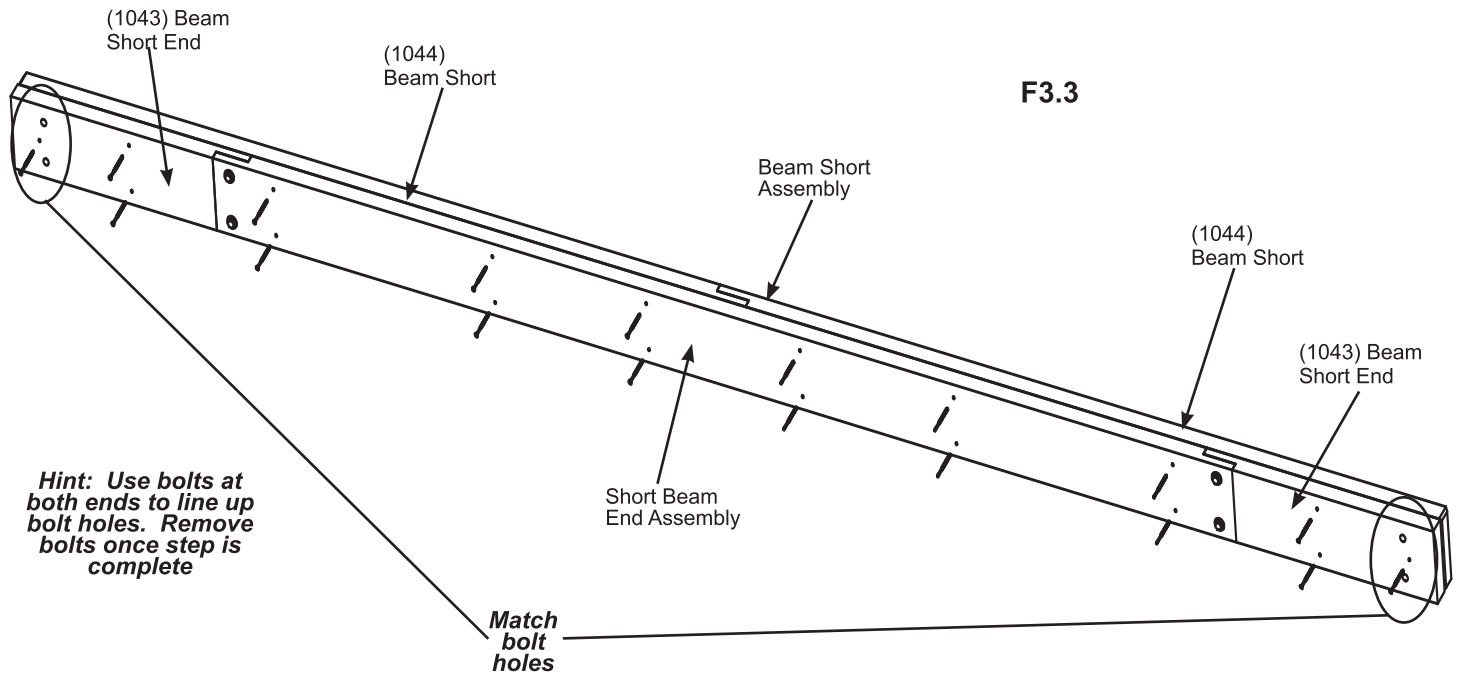

Hardware

36 x #8 x 2-1/2" Wood Screw

Step 4: Long Beam Assembly Part 1

A: Connect two (1045) Beam Longs using two 5/16 x 1-1/2" Hex Bolts (with 5/16" lock washer, 1/4-5/16" large washer and 5/16" t-nut) as shown in F4.1 and F4.2.

B: Connect one (1047) Beam Long End to each end of one (1046) Long Beam Centre using one 5/16 x 1-1/2" Hex Bolts (with 5/16" lock washer, 1/4-5/16" large washer and 5/16" t-nut) in the top hole, per end as shown in F4.1 and F4.2.

C: Repeat Steps A and B one more time to make two Beam Long Assemblies and two Long Beam End Assemblies.

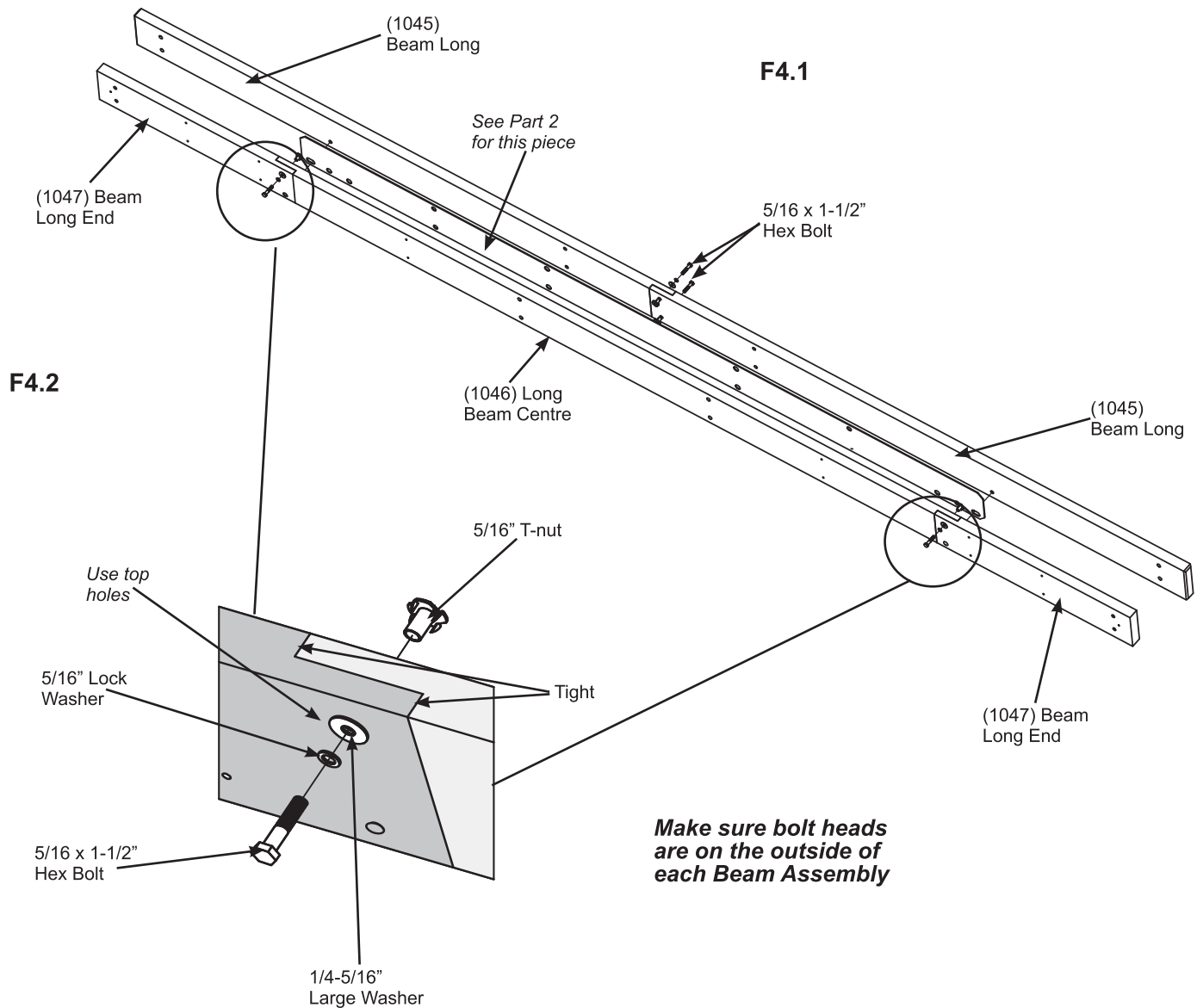

Wood Parts

- 4 x (1045) Beam Long
- 2 x (1046) Long Beam Centre
- 4 x (1047) Beam Long End

Hardware

- 8 x 5/16 x 1-1/2" Hex Bolt
(5/16" lock washer, 1/4-5/16" large washer, 5/16" t-nut)

Step 4: Long Beam Assembly Part 2



D: Place one Long Beam Insert in between one Beam Long Assembly and one Long Beam End Assembly then fit tight together. Beam Long Assembly overhangs Long Beam End Assembly by 1-3/8" on each end. Match the bolt holes and wood screw pilot holes in both beam assemblies and Long Beam Insert. (F4.3, F4.4 and F4.5)

E: Attach beam assemblies and Long Beam Insert together with six 5/16 x 3" Hex Bolts (with 5/16" lock washer, 1/4-5/16" large washer and 5/16" t-nut) and 14 #8 x 2-1/2" Wood Screws. (F4.5, F4.6 and F4.7)

F: Repeat Step D-E make a second Long Beam Assembly.

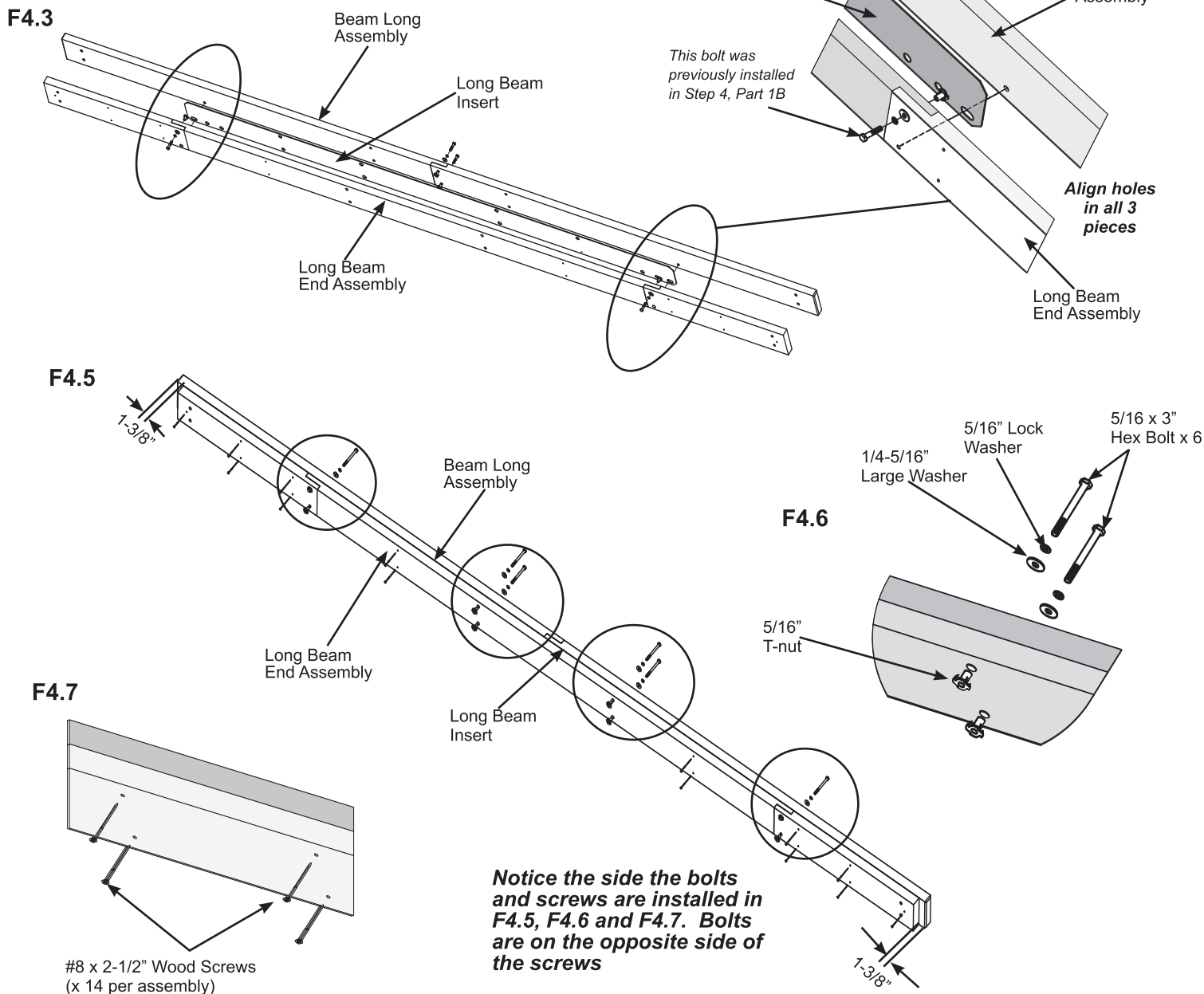

Componets:

2 x Long Beam Insert

Hardware

28 x #8 x 2-1/2" Wood Screw
 12 x 5/16 x 3" Hex Bolt
 (5/16" lock washer, 1/4-5/16" large washer, 5/16" t-nut)

Step 5: Frame Assembly

Part 1 - Short Side

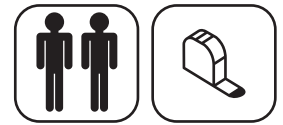

A: Against the short sides of one Post Right Assembly and one Post Left Assembly place one Short Beam Assembly and loosely attach with one 3/8 x 10" Hex Bolt (with two 3/8" large washers and one 3/8" lock nut) per post in the bottom holes. The distance from the outside of one post to the outside of the second post should be 10' 10-3/8" (3.312m). (F5.1, F5.2 and F5.3)

B: On each end of the Short Beam Assembly, tight to the bottom and flush to the outside edges, place one (1053) Arched Gusset Short. Loosely attach gussets, in the top holes, with one 3/8 x 10" Hex Bolt (with two 3/8" large washers and one 3/8" lock nut) per post. (F5.1 and F5.2)

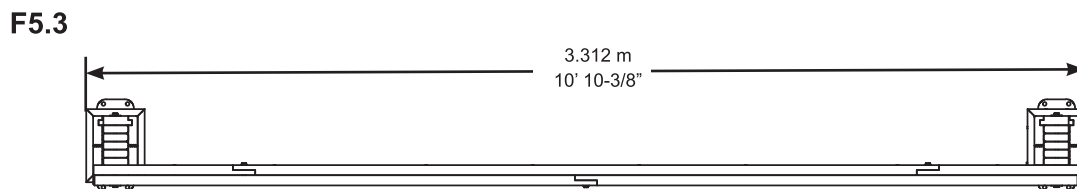
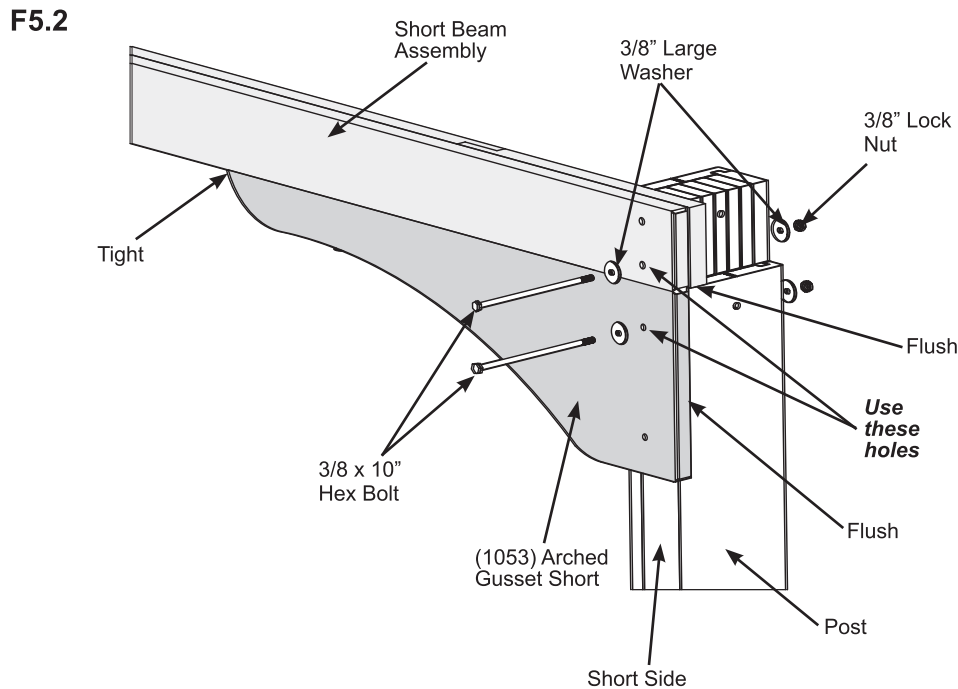
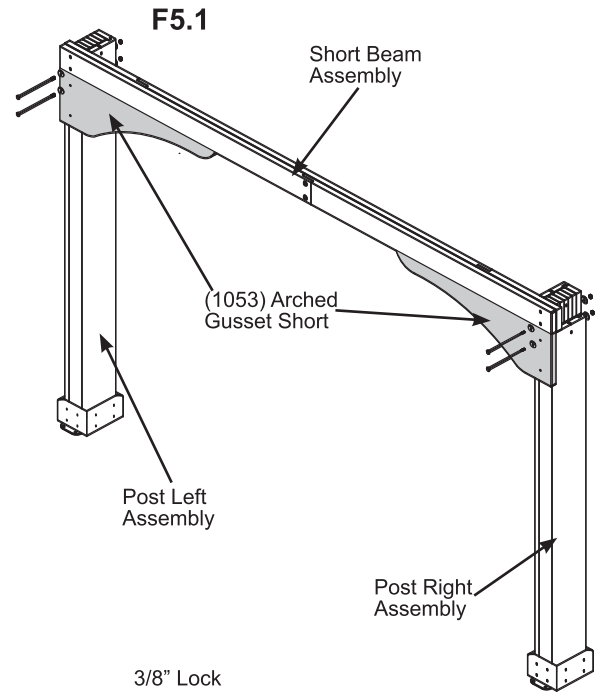

Wood Parts

4 x (1053) Arched Gusset Short

Hardware

8 x 3/8 x 10" Hex Bolt (3/8" large washer x 2, 3/8" lock nut)

Step 5: Frame Assembly

Part 2 - Short Side

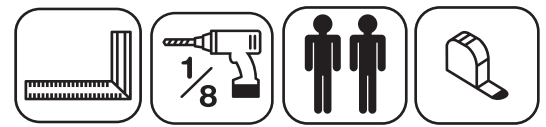

C: Make sure Short Beam Assembly is square to Posts then pre-drill with a 1/8" drill bit in the top holes of each Short Beam Assembly and bottom hole of (1053) Arched Gusset Short, then attach with two 5/16 x 4" Lag Screws (with 1/4-5/16" large washer) per end. Tighten all bolts. (F5.4 and F5.5)

D: Pre-drill with a 1/8" drill bit then attach each (1053) Arched Gusset Short to Short Beam Assembly with two 5/16 x 4" Lag Screws (with 5/16" flat washer) per gusset. (F5.4, F5.5 and F5.6)

E: Repeat Step A-D make a second Short Side Assembly.

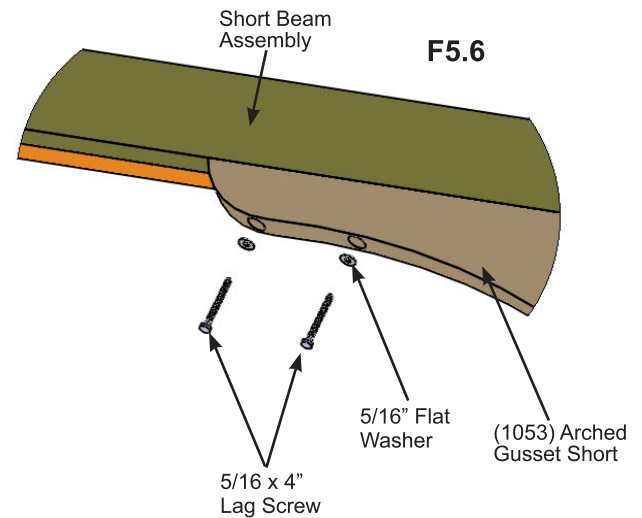
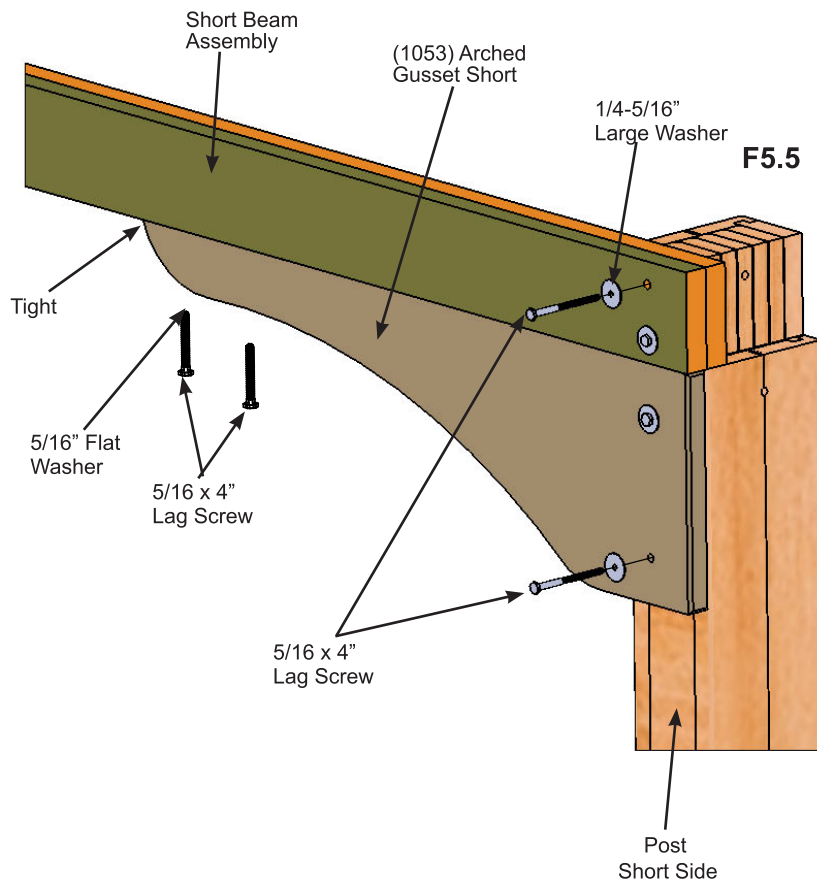
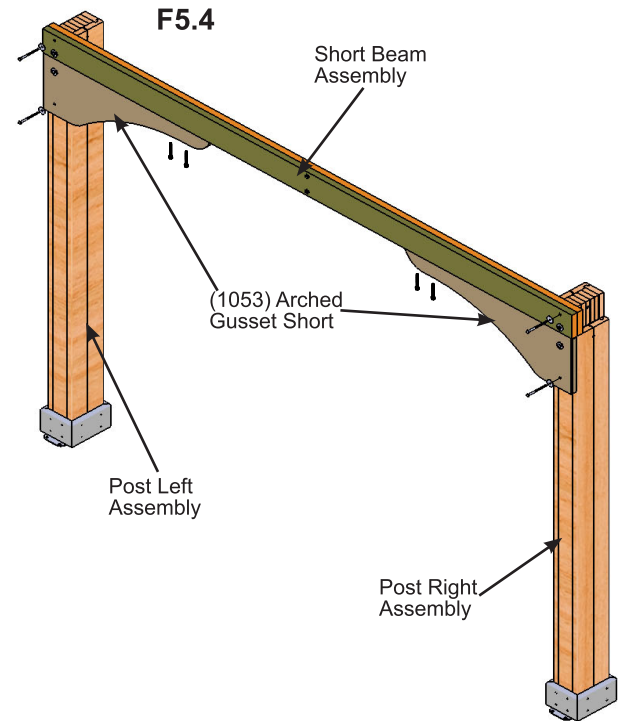

Hardware

- 8 x 5/16 x 4" Lag Screw (1/4-5/16" large washer)
- 8 x 5/16 x 4" Lag Screw (5/16" flat washer)

Step 5: Frame Assembly

Part 3 - Long Side



F: Move your Post Assemblies to the final location. Make sure the ground is flat and level before continuing assembly.

G: Stand each Short Side Assembly then place one Long Beam Assembly against the long sides of each post, flush to the tops tight to the Short Side Assemblies. Notice bolt heads on the Long Beam Assembly are towards the bottom. Attach Long Beam Assemblies to each post with one 3/8 x 8" Hex Bolt (with two 3/8" large washers and one 3/8" lock nut) per post in the top holes. The distance from the outside of one Post to the outside of the second Post should be 12' 10-3/8" (3.921m). (F5.7 and F5.8) Check F5.9 for accurate positioning of Posts.

H: At each end of each Long Beam Assembly place one (1049) Arched Gusset, tight to the bottom of the beam. Attach gussets, in the top holes, with one 3/8 x 8" Hex Bolt (with two 3/8" large washers and one 3/8" lock nut) per post. (F5.7 and F5.8)

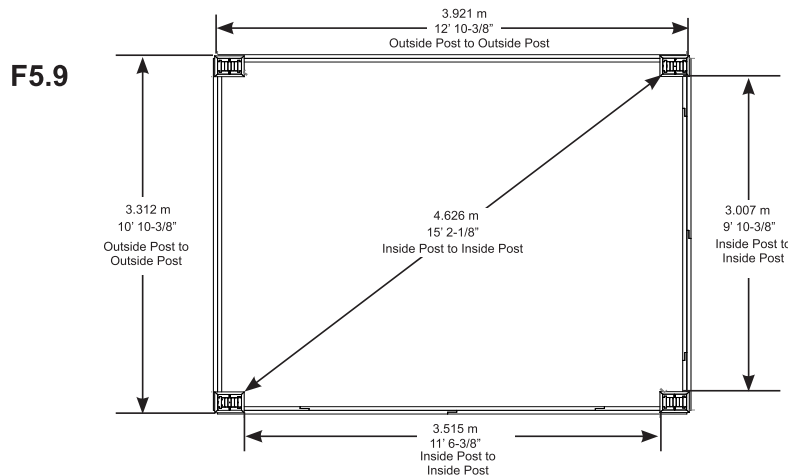
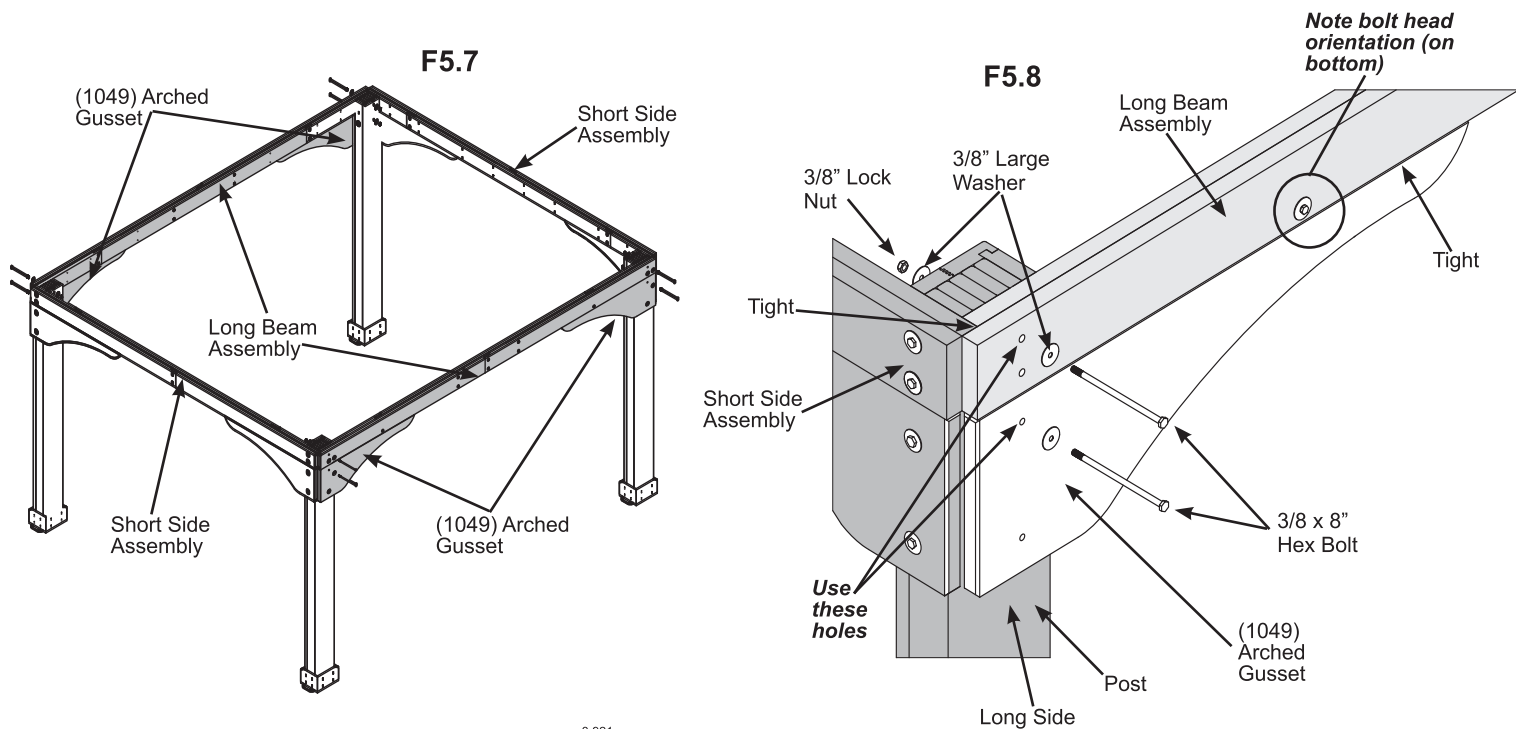

Wood Parts

4 x (1049) Arched Gusset

Hardware

8 x 3/8 x 8" Hex Bolt (3/8" large washer x 2, 3/8" lock nut)

Step 5: Frame Assembly

Part 4 - Long Side

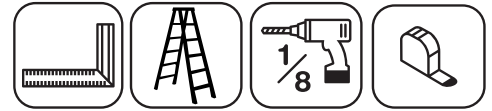

I: Make sure Long Beam Assembly is square to Posts then pre-drill with a 1/8" drill bit in the bottom holes of each Long Beam Assembly and (1049) Arched Gusset then attach with two 5/16 x 4" Lag Screws (with 1/4-5/16" large washer) per post. (F5.10)

J: Pre-drill with a 1/8" drill bit then attach each (1049) Arched Gusset to Long Beam Assembly with two 5/16 x 4" Lag Screws (with 5/16" flat washer) per gusset. (F5.10 and F5.11)

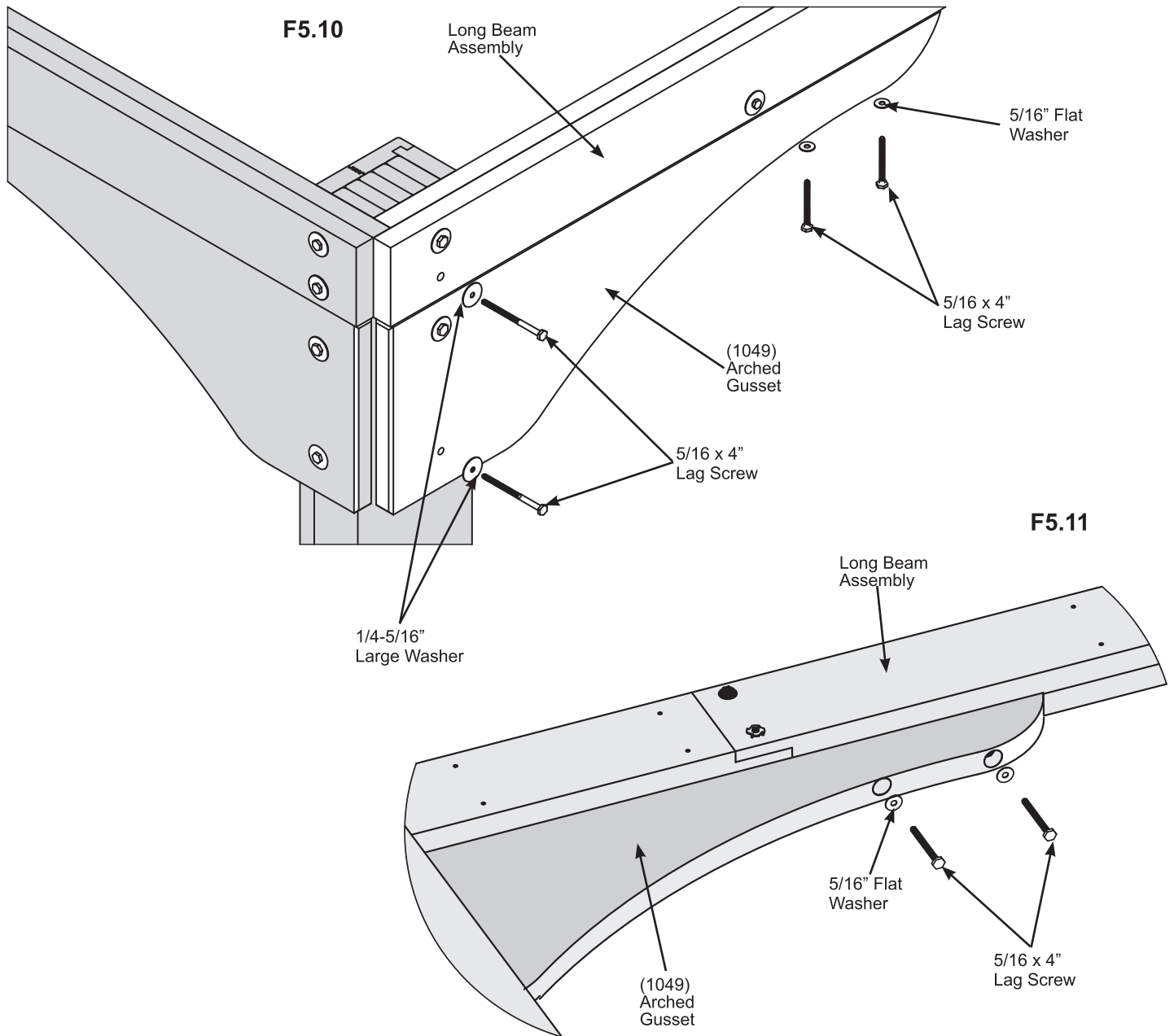

Hardware

8 x 5/16 x 4" Lag Screw (1/4-5/16" large washer)

8 x 5/16 x 4" Lag Screw (5/16" flat washer)

Step 6: Attach Roof Brackets



A: At each corner, tight to the outside edges of the joining Beam Assemblies attach one Rafter to Post Bracket with two #8 x 1" Pan Screws. (F6.1 and F6.2)

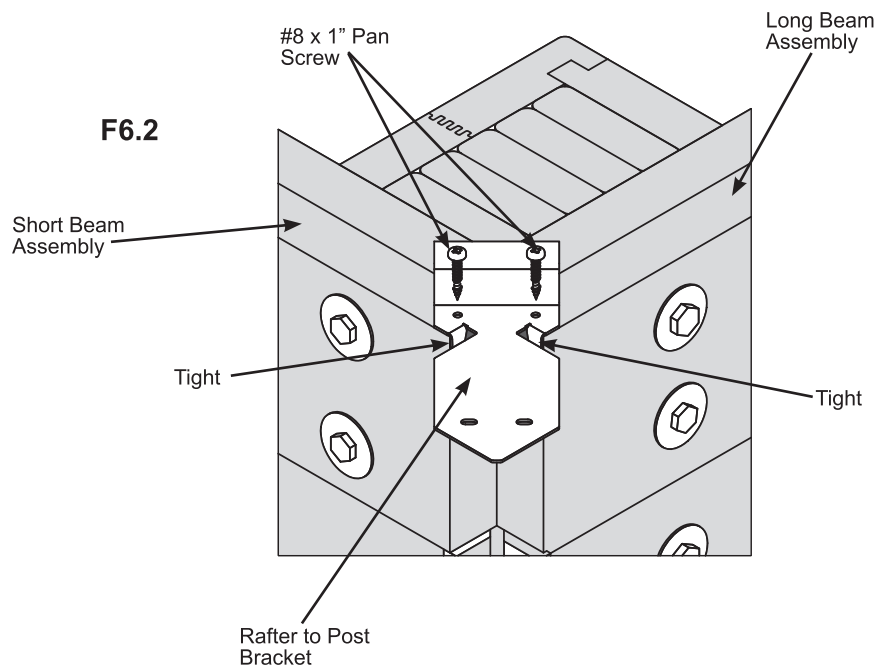
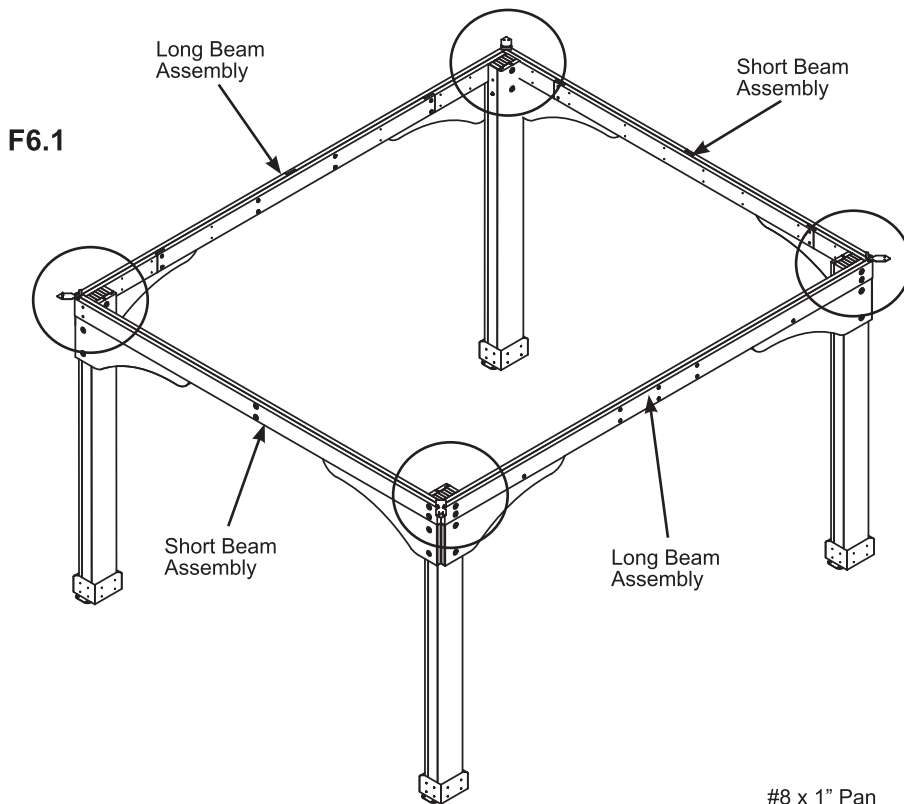

Components

4 x Rafter to Post Bracket

Hardware

8 x #8 x 1" Pan Screw

Step 7: Fascia Beam Assemblies

A: Tightly connect one (443) Fascia Left and one (444) Fascia Right using one 5/16 x 1-1/2" Hex Bolt (with 5/16" lock washer, 1/4-5/16" large washer and 5/16" t-nut) as shown in F7.1 and F7.2. Repeat to make a second Fascia Beam Assembly.

B: Tightly connect one (435) Fascia Left - Large Roof and one (436) Fascia Right - Large Roof using one 5/16 x 1-1/2" Hex Bolt (with 5/16" lock washer, 1/4-5/16" large washer and 5/16" t-nut) as shown in F7.3 and F7.4. Repeat to make a second Large Fascia Beam Assembly.

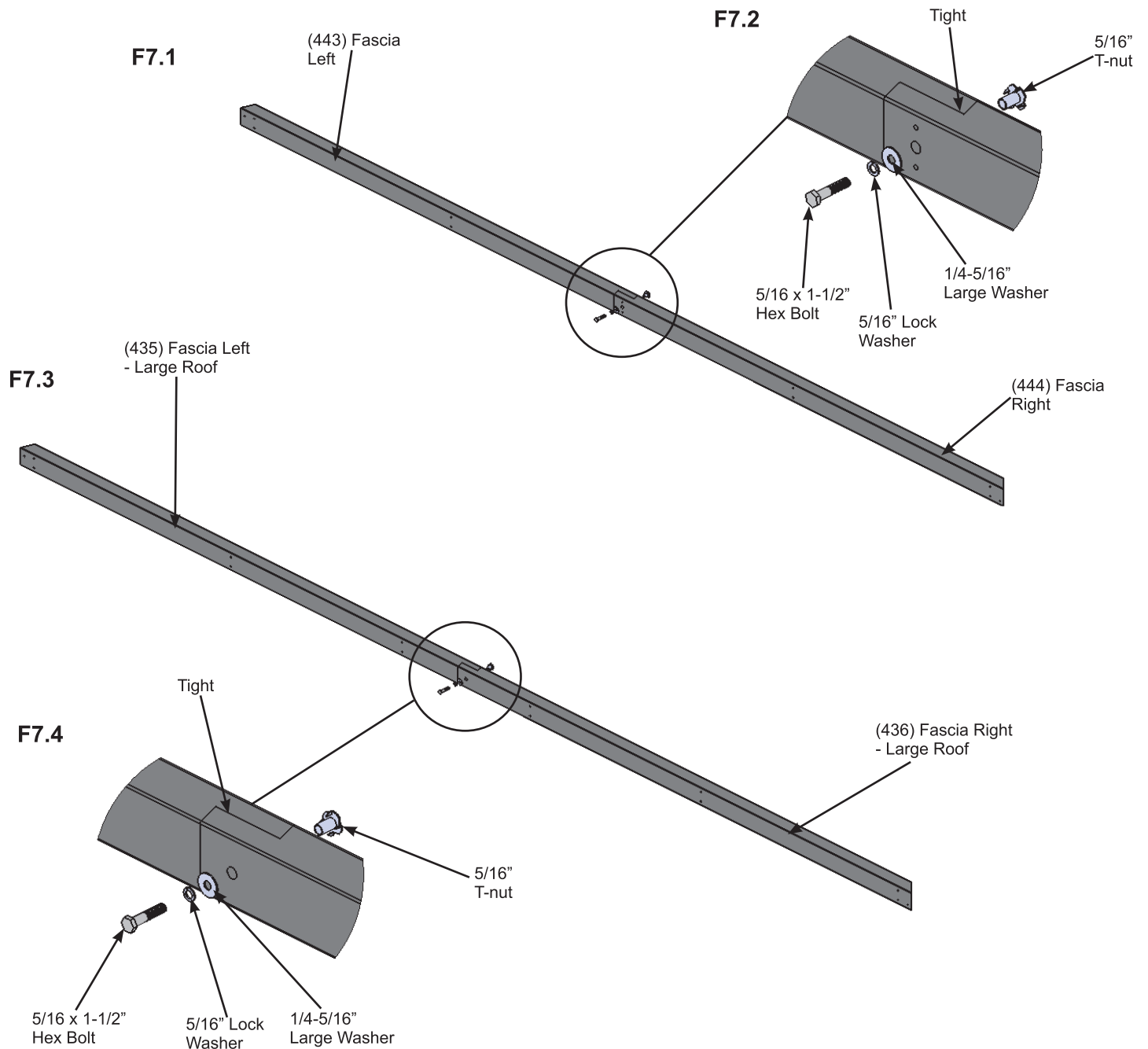

Wood Parts

- 2 x (443) Fascia Left
- 2 x (444) Fascia Right
- 2 x (435) Fascia Left - Large Roof
- 2 x (436) Fascia Right - Large Roof

Hardware

- 4 x 5/16 x 1-1/2" Hex Bolt
(5/16" lock washer, 1/4-5/16" large washer, 5/16" t-nut)

Step 8: Small Roof Rafter Assembly Part 1

A: On each side of one (440) Rafter place one (438) Rafter Corner Left and one (439) Rafter Corner Right so the tops and edges are flush then attach with two #8 x 2-1/4" Wood Screws per side. (F8.1 and F8.2)

B: Place Fascia Beam Assembly from Step 7A on the bottom of (438) Rafter Corner Left, (439) Rafter Corner Right and (440) Rafter so the sides are flush then attach with two #8 x 2-1/4" Wood Screws at each end and two in the middle. (F8.1, F8.3 and F8.4)

C: Repeat Steps A and B to make a second Small Roof Rafter Assembly.

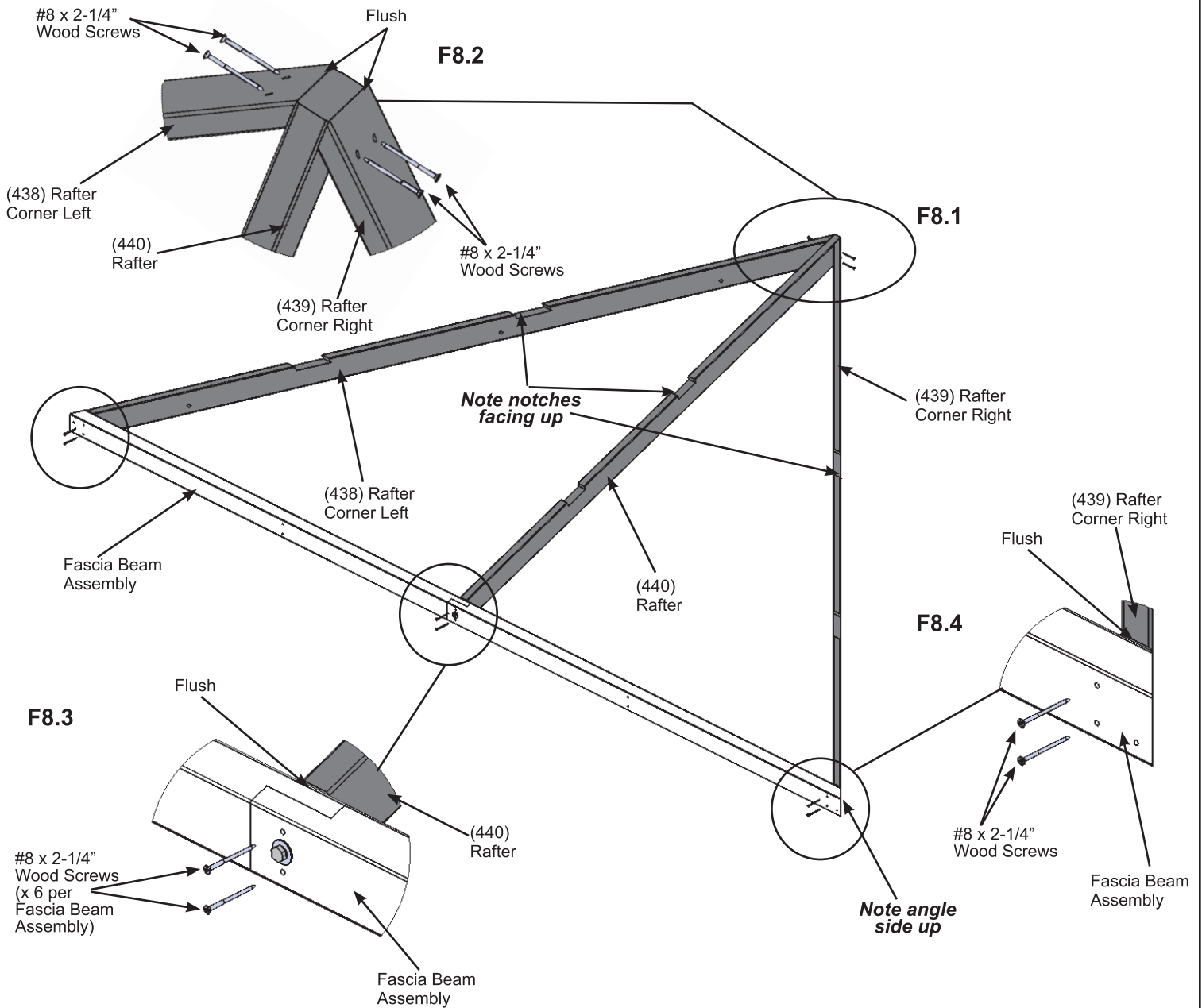

Wood Parts

- 2 x (440) Rafter
- 2 x (438) Rafter Corner Left
- 2 x (439) Rafter Corner Right

Hardware

- 20 x #8 x 2-1/4" Wood Screw

Step 8: Small Roof Rafter Assembly Part 2

D: Place one (337) Strap Short in the notches of (438) Rafter Corner Left, (439) Rafter Corner Right and (440) Rafter so the ends do not overhang the outside edges of the outside boards then attach with six #8 x 1-1/2" Wood Screws. (F8.5)

E: Place one (437) Strap in the notches of (438) Rafter Corner Left, (439) Rafter Corner Right and (440) Rafter so the ends do not overhang the outside edges of the outside boards. Do not attach yet. (F8.5)

F: Place one (442) Rafter Short Right and one (441) Rafter Short Left in the notches of (437) Strap and attach as shown in F8.5 with four #8 x 1-1/2" Wood Screws and two #8 x 2-1/4" Wood Screws per board.

G: Attach (437) Strap to (438) Rafter Corner Left, (439) Rafter Corner Right and (440) Rafter with six #8 x 1-1/2" Wood Screws. (F8.5)

H: Complete Steps D, E, F and G for both Small Roof Rafter Assemblies.

F8.5

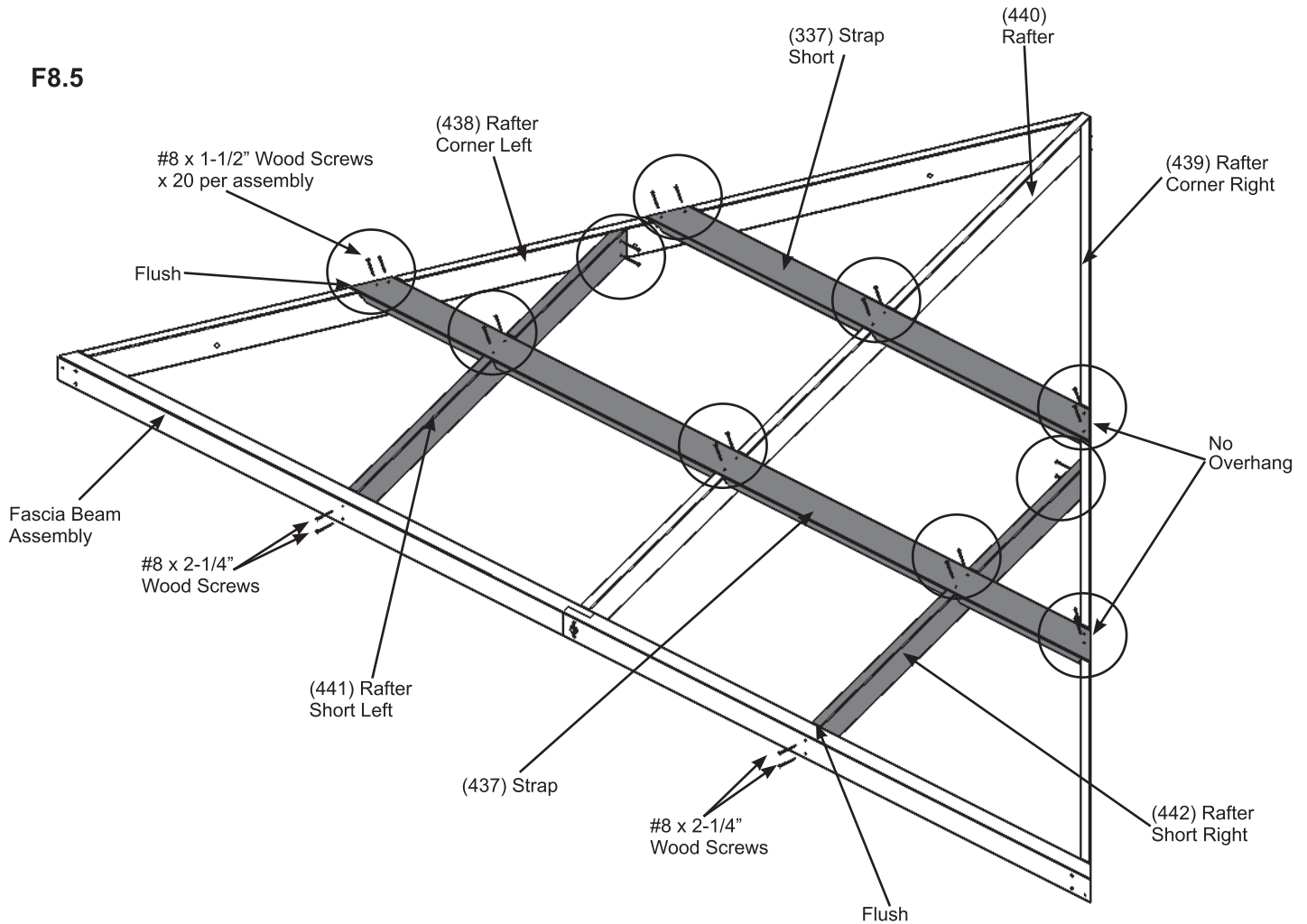

Wood Parts

- 2 x (337) Strap Short
- 2 x (437) Strap
- 2 x (442) Rafter Short Right
- 2 x (441) Rafter Short Left

Hardware

- 40 x #8 x 1-1/2" Wood Screw
- 8 x #8 x 2-1/4" Wood Screw

Step 9: Attach Roof to Beam Brackets - Small Roof Rafter Assembly



A: On the Back of one Small Roof Rafter Assembly, centred and 1-1/2" (3.81 cm) from the bottom of (442) Rafter Short Right, (441) Rafter Short Left and (440) Rafter attach one Roof to Beam Bracket per board with one #8 x 1" Pan Screw in the bottom hole and one #12 x 1-1/2" Pan Screw in the top hole per bracket. Make sure to only install on one Small Roof Rafter Assembly, the second will not have brackets. (F9.1 and F9.2)

F9.1
Back View

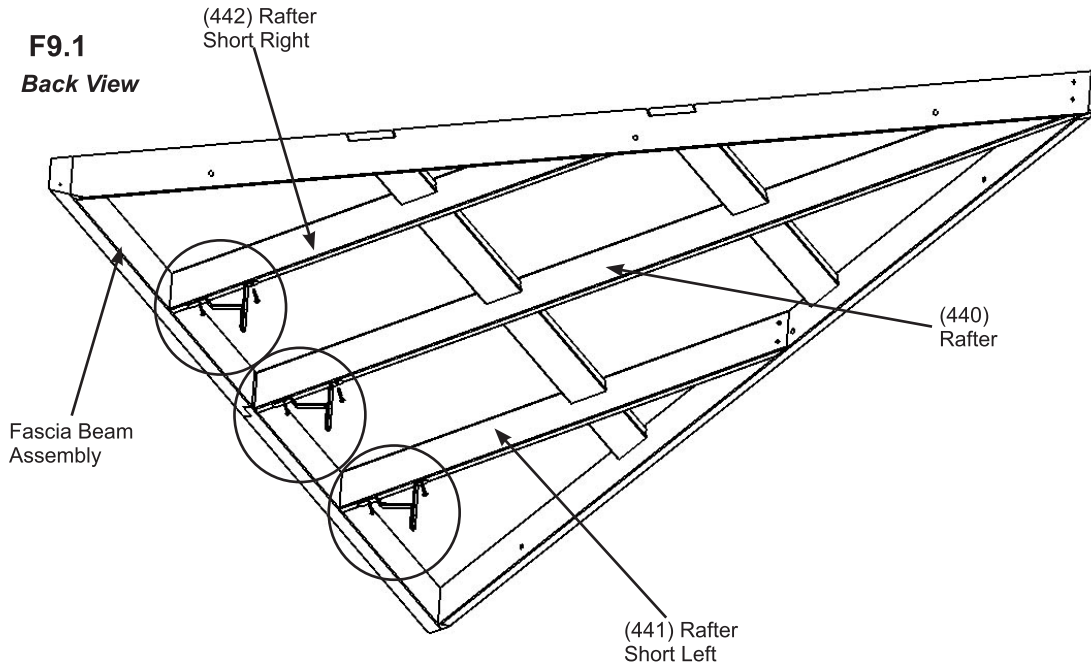

F9.2

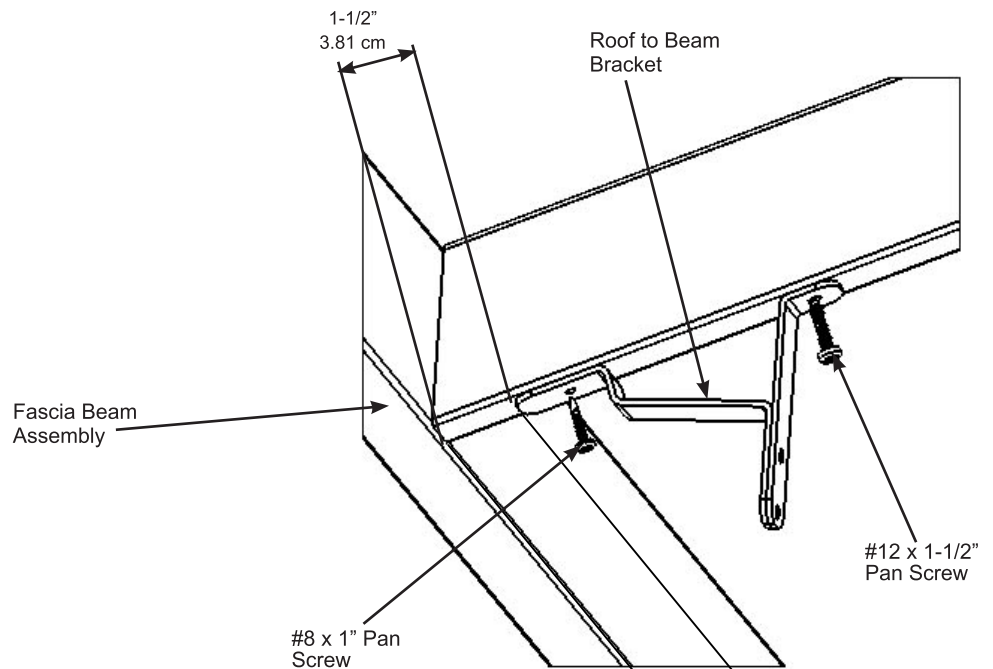

Components

3 x Roof to Beam Bracket

Hardware

3 x #8 x 1" Pan Screw

3 x #12 x 1-1/2" Pan Screw

Step 10: Large Roof Rafter Assembly Part 1

A: On each side of one (434) Top place one (440) Rafter so the tops and edges are flush then attach with two #8 x 2-1/2" Wood Screws per side. (F10.1 and F10.2)

B: Place Large Fascia Beam Assembly from Step 7B on the bottom of (440) Rafters so the sides are flush and holes are centred on the (440) Rafters then attach with two #8 x 2-1/4" Wood Screws per (440) Rafter. (F10.1 and F10.3)

C: Repeat Steps A and B to make a second Large Roof Rafter Assembly.

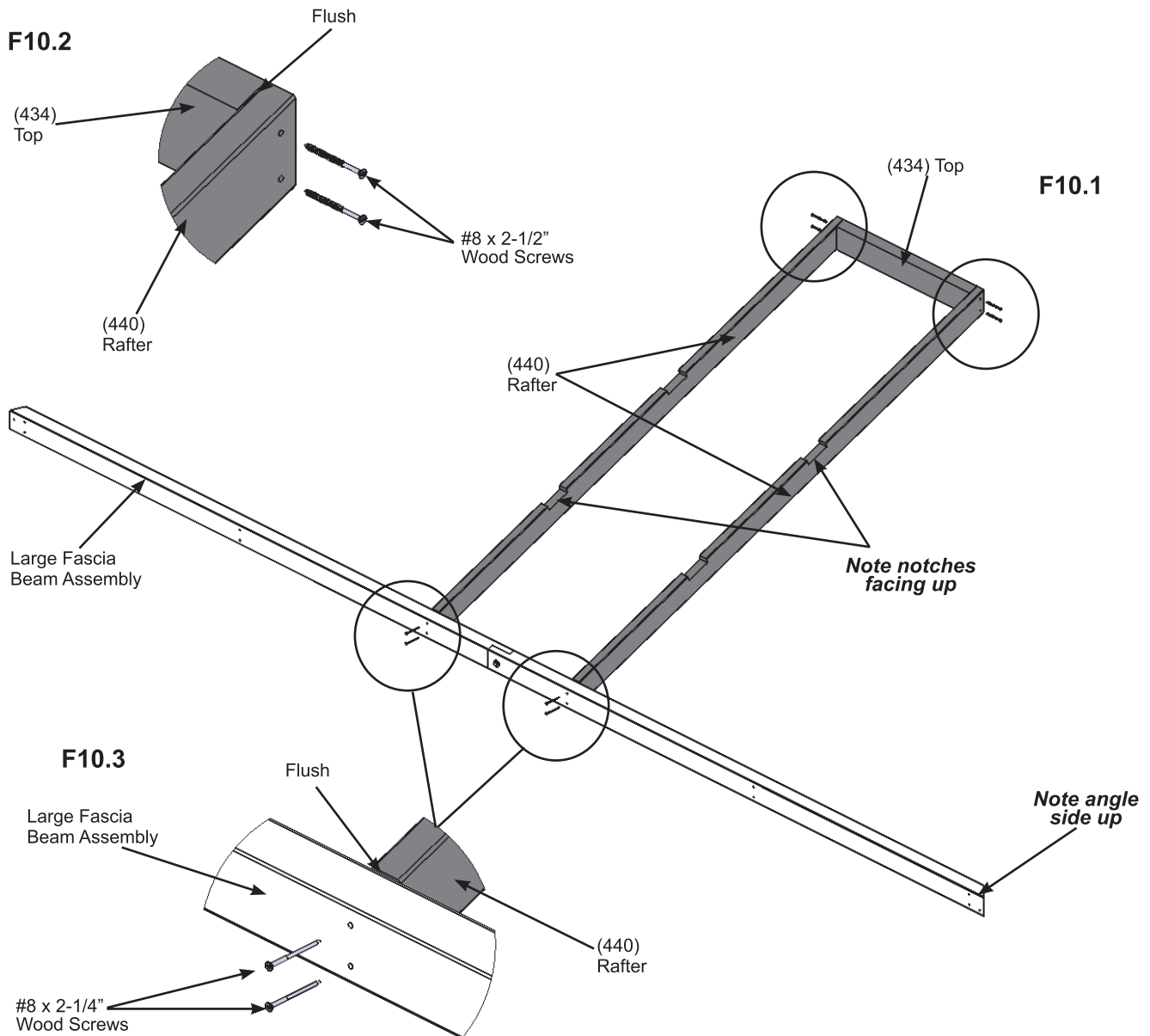

Wood Parts

4 x (440) Rafter
2 x (434) Top

Hardware

8 x #8 x 2-1/4" Wood Screw
8 x #8 x 2-1/2" Wood Screw

Step 10: Large Roof Rafter Assembly Part 2

D: Beside each (440) Rafter place one (438) Rafter Corner Left and one (439) Rafter Corner Right so the tops and edges are flush and the bottom edges are flush to Large Fascia Beam Assembly then attach with two #8 x 2-1/4" Wood Screws to the top and bottom of the rafters per side. (F10.4, F10.5 and F10.6)

E: Repeat Step D for the second Large Roof Rafter Assembly.

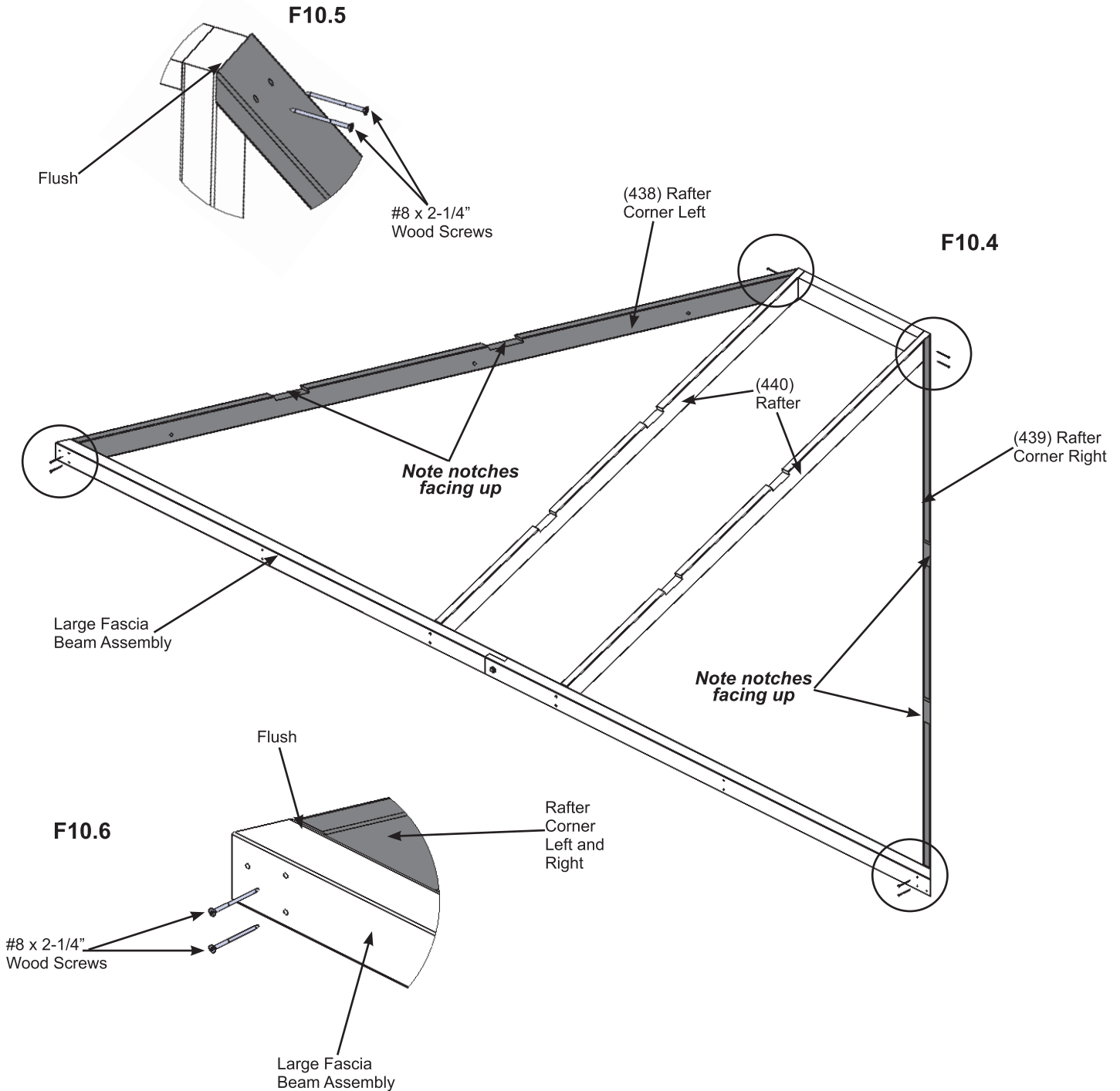

Wood Parts

- 2 x (438) Rafter Corner Left
- 2 x (439) Rafter Corner Right

Hardware

- 16 x #8 x 2-1/4" Wood Screw

Step 10: Large Roof Rafter Assembly Part 3

F: Place one (430) Strap Short - Large Roof in the notches of (438) Rafter Corner Left, (439) Rafter Corner Right and both (440) Rafters so the ends do not overhang the outside edges of the outside boards then attach with eight #8 x 1-1/2" Wood Screws. (F10.7)

G: Place one (431) Strap Left - Large Roof in the notches of (438) Rafter Corner Left and one (440) Rafter and one (432) Strap Right - Large Roof in the notches of (439) Rafter Corner Right and the other (440) Rafter so the ends do not overhang the outside edges of the outside boards. Boards are tight in the centre. Do not attach yet. (F10.7)

H: Place one (442) Rafter Short Right in the notches of (432) Strap Right - Large Roof and one (441) Rafter Short Left in the notches of (431) Strap Left - Large Roof and attach to (438) Rafter Corner Left and (439) Rafter Corner Right with two #8 x 1-1/2" Wood Screws per board and to Large Fascia Beam Assembly with two #8 x 2-1/4" Wood Screws per board. (F10.7)

I: Attach (431) Strap Left - Large Roof and (432) Strap Right - Large Roof to (438) Rafter Corner Left, (439) Rafter Corner Right and (440) Rafter with six #8 x 1-1/2" Wood Screws per board. (F10.7)

F10.7

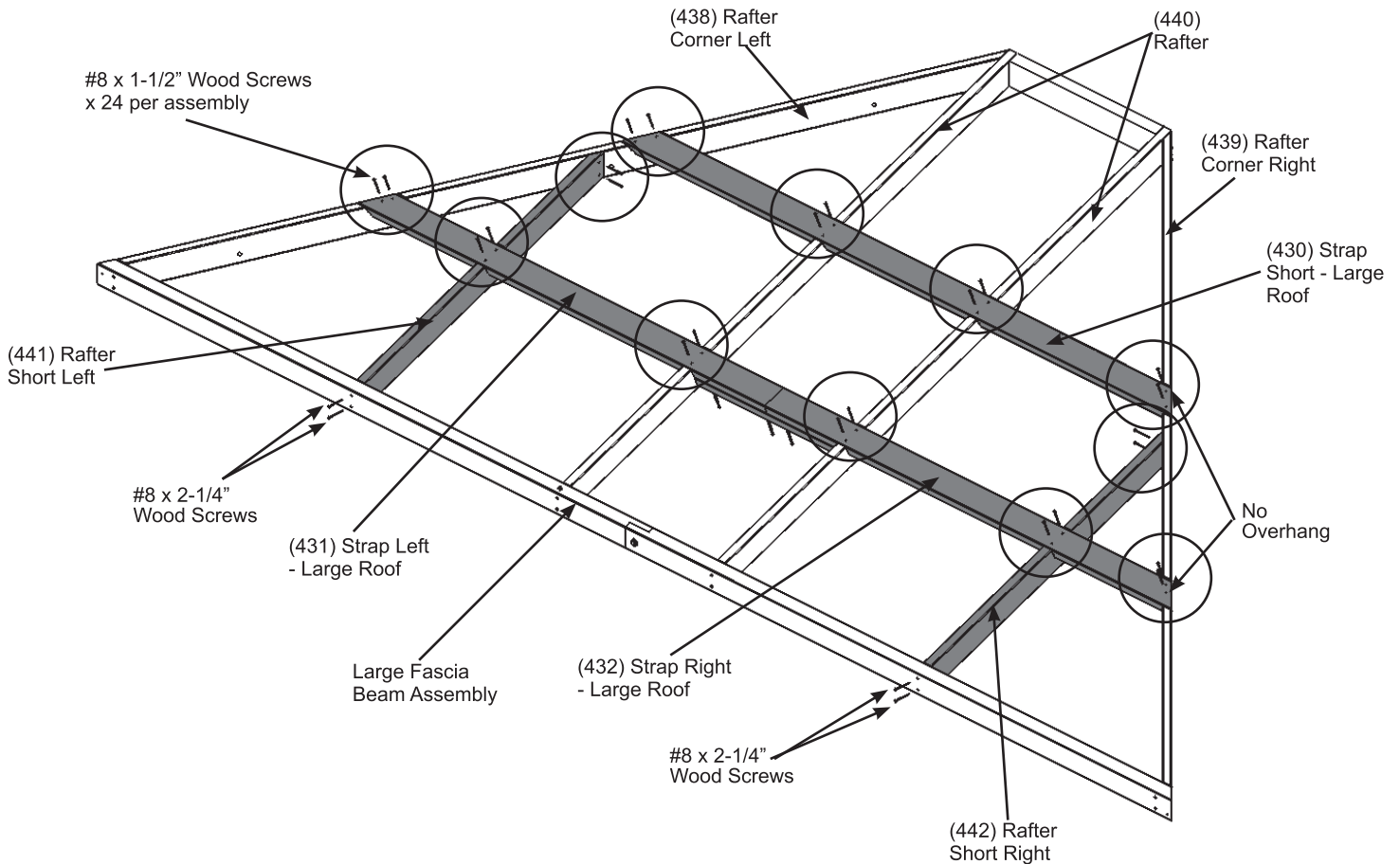

Wood Parts

- 2 x (430) Strap Short - Large Roof
- 2 x (431) Strap Left - Large Roof
- 2 x (432) Strap Right - Large Roof
- 2 x (442) Rafter Short Right
- 2 x (441) Rafter Short Left

Hardware

- 48 x #8 x 1-1/2" Wood Screw
- 8 x #8 x 2-1/4" Wood Screw

Step 10: Large Roof Rafter Assembly Part 4

J: Turn Large Roof Rafter Assembly over then attach one (433) Strap Brace to (431) Strap Left - Large Roof and (432) Strap Right - Large Roof with eight #8 x 2-1/4" Wood Screws. Edges are flush. (F10.8 and F10.9)

K: Complete Steps F - J for both Large Roof Rafter Assemblies.

F10.8
Front View

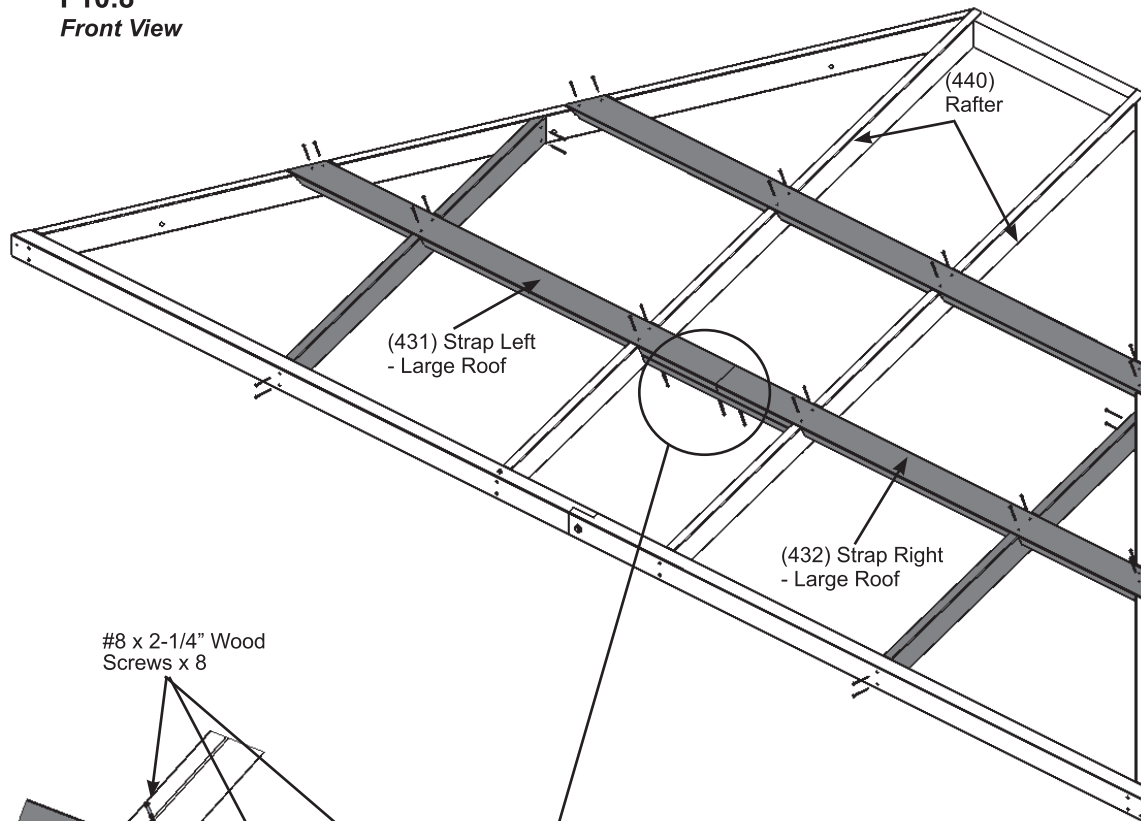

F10.9
Back View

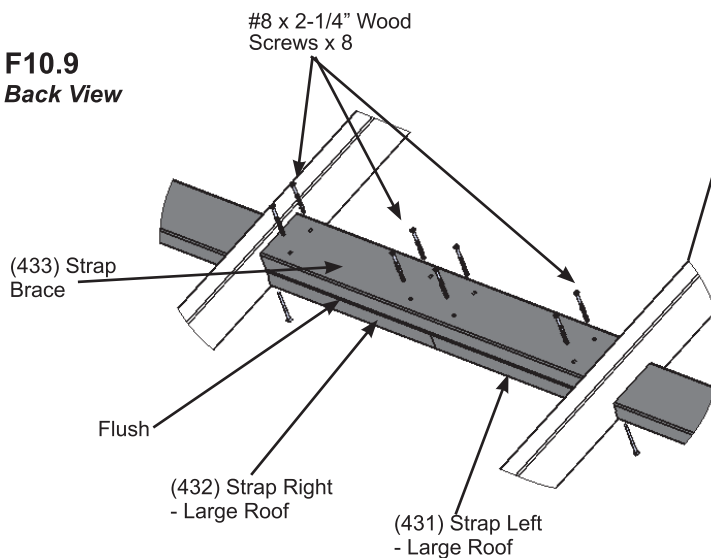

Wood Parts

2 x (433) Strap Brace

Hardware

16 x #8 x 2-1/4" Wood Screw

Step 11: Attach Roof to Beam Brackets - Large Roof Rafter Assemblies



A: On the Back of both Large Roof Rafter Assemblies, centred and 1-1/2" (3.81 cm) from the bottom of (442) Rafter Short Right, (441) Rafter Short Left and both (440) Rafter attach one Roof to Beam Bracket per board with one #8 x 1" Pan Screw in the bottom hole and one #12 x 1-1/2" Pan Screw in the top hole per bracket. (F11.1 and F11.2)

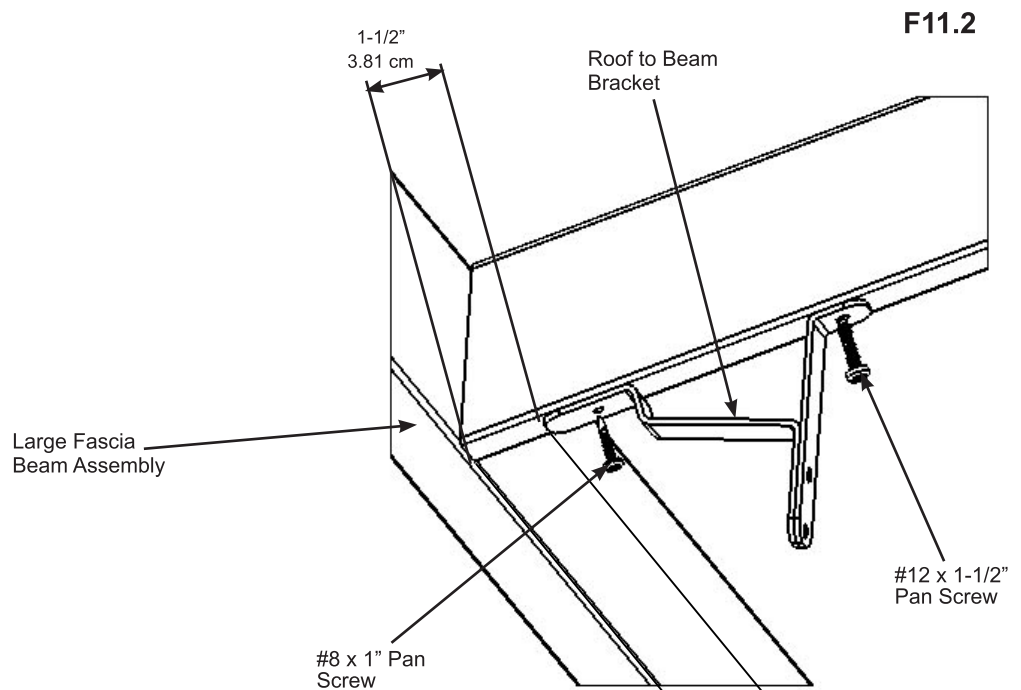
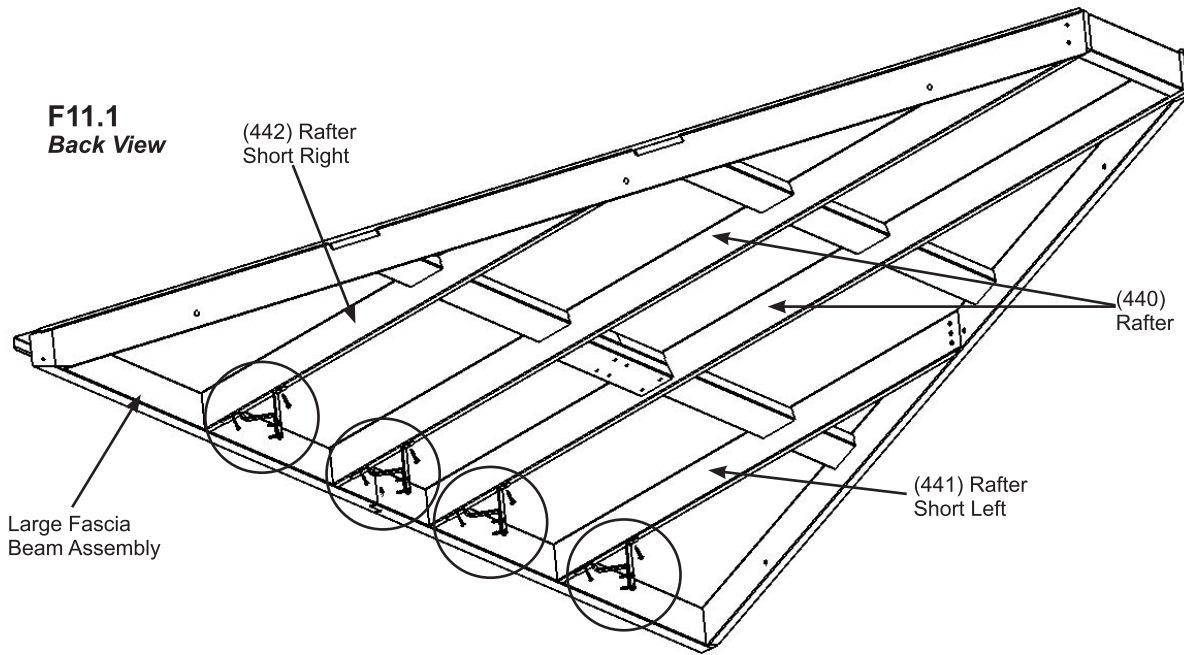

Components

8 x Roof to Beam Bracket

Hardware

8 x #8 x 1" Pan Screw

8 x #12 x 1-1/2" Pan Screw

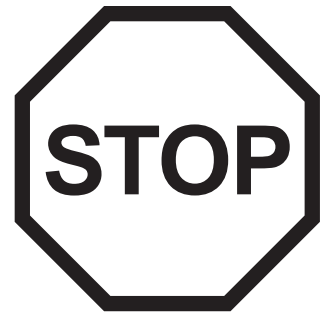
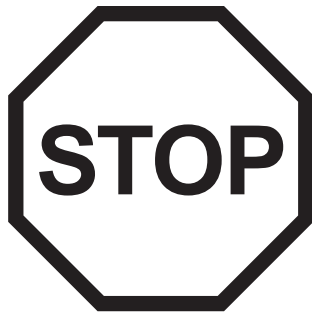

INSTALLING ROOFING MATERIAL

CAUTION!

Roofing material may have sharp edges! Wear gloves!

HANDLE WITH CARE!

Place roofing material on a non-abrasive surface before assembly as it can bend, dent and scratch easily.

**WARNING – DO NOT OVER TIGHTEN ROOFING SCREWS!
Over tightening screws will cause roofing material to crush.**

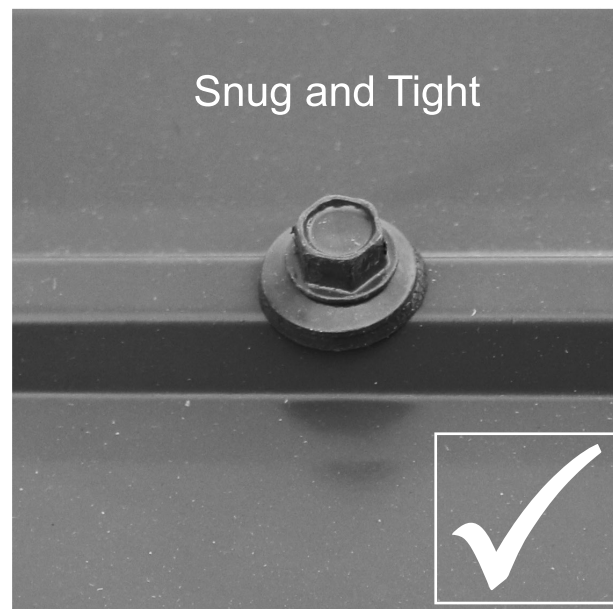

The roofing screws can easily crush the Roof Panels and Roof Edges when using a power drill. We recommend hand tightening the roofing screws so that they sit snug and tight to the roofing material.

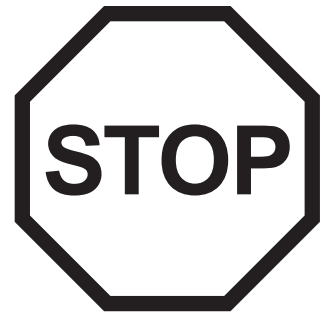
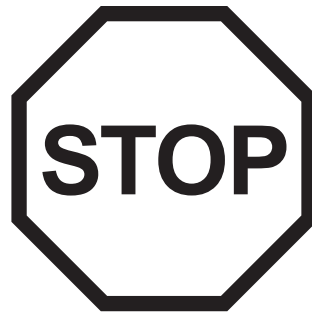

INSTALLING ROOFING MATERIAL

CAUTION!

Roofing material may have sharp edges! Wear gloves!

BE SURE TO REMOVE ALL PLASTIC COVERING, ON BOTH SIDES OF THE ALUMINUM PANELS AND TRIM, DIRECTLY BEFORE INSTALLING EACH PIECE. *(One side is clear and the other is blue, both must be removed.)*

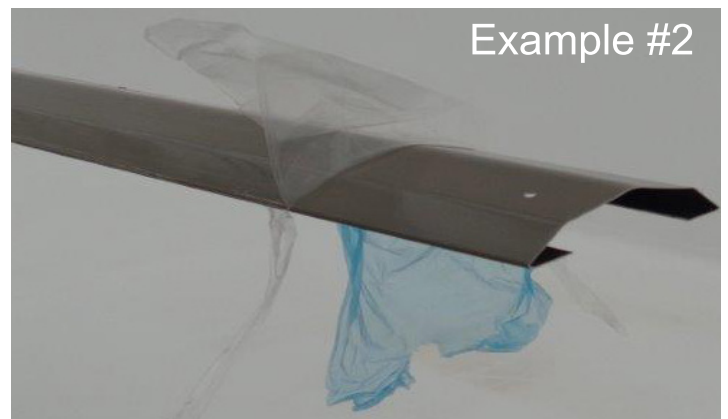
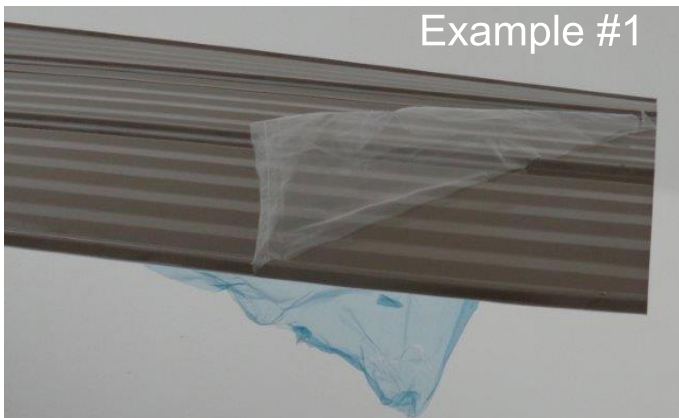

Step 12: Attach Roof Panels - Small Roof

Part 1

A: Place one Long Panel Left on the front of one Small Roof Rafter Assembly so it is flush to the side of (438) Rafter Corner Left and a slight overhang at the bottom of the Fascia Beam Assembly. Holes should line up with (440) Rafter. (F12.1 and F12.2)

B: Place one Long Panel Right on Small Roof Rafter Assembly so it overlaps the Long Panel Left and it is flush to the side of (439) Rafter Corner Right and a slight overhang at the bottom of the Fascia Beam Assembly. (F12.1 and F12.2)

C: Attach both Left and Right Long Panels to Small Roof Rafter Assembly with four #8 x 1" Roofing Screws in locations shown in F12.1. Be sure not to overtighten screws.

D: Repeat Steps A - C for both Small Roof Rafter Assemblies.

DO NOT overtighten screws, could cause damage to roofing material

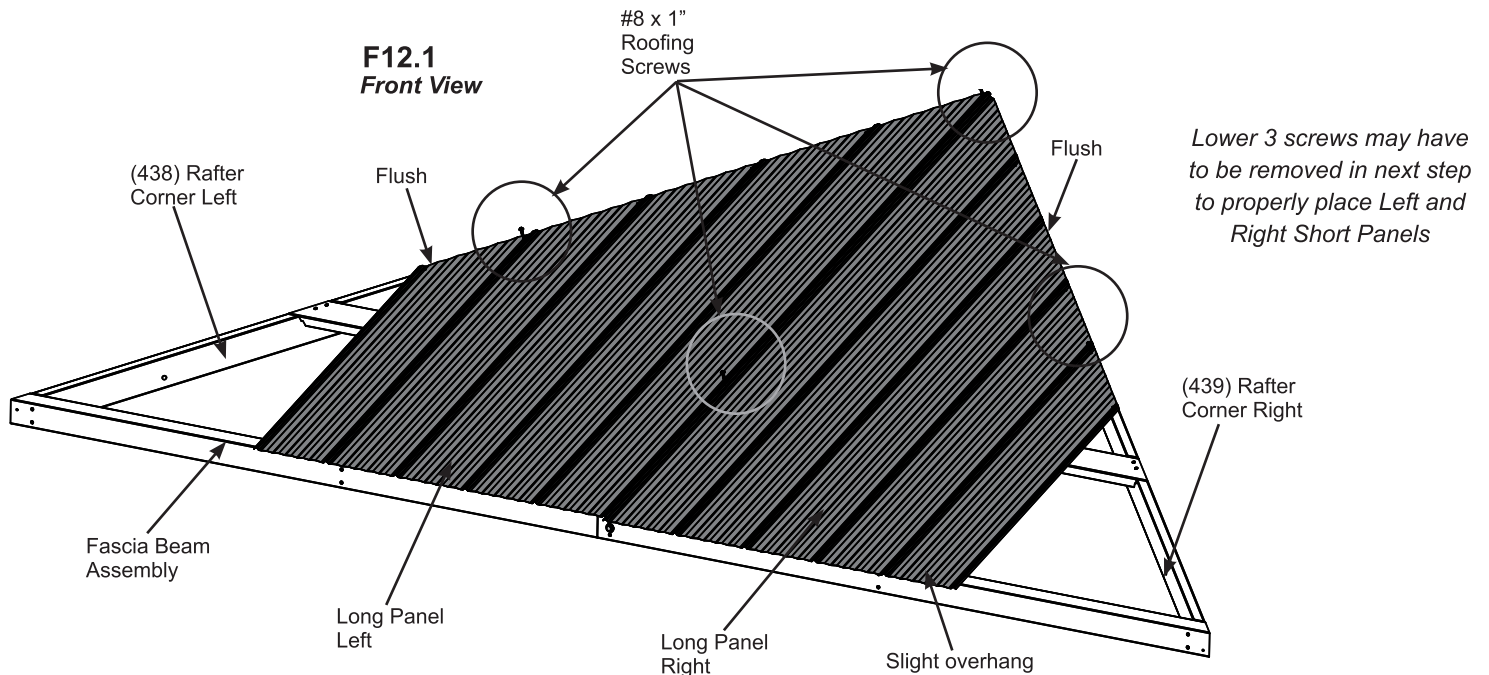
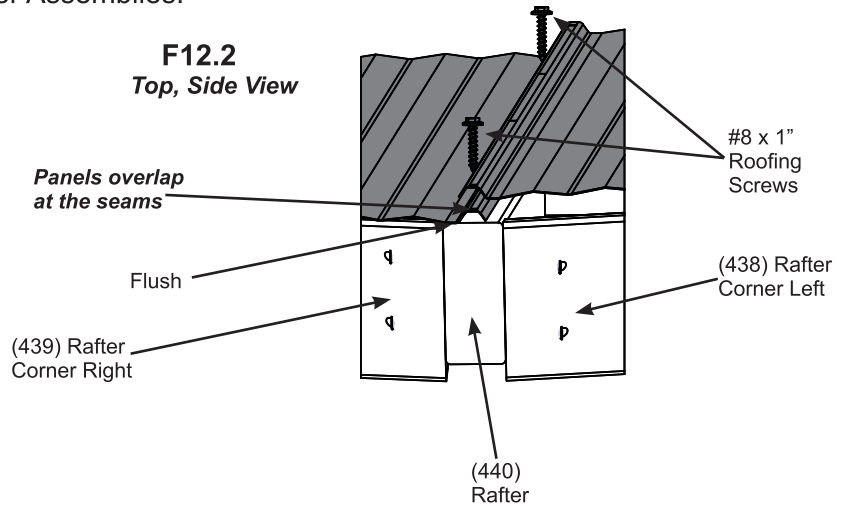

Roof Parts

2 x Long Panel Left
2 x Long Panel Right

Hardware

8 x #8 x 1" Roofing Screw

Step 12: Attach Roof Panels - Small Roof Part 2

E: Place one Short Panel Left on Small Roof Rafter Assembly so it overlaps the Long Panel Left and it is flush to the sides of (438) Rafter Corner Left and a slight overhang at the bottom of the Fascia Beam Assembly. There should be no overhanging at the corners. (F12.3 and F12.4)

F: Place one Short Panel Right on Small Roof Rafter Assembly so it overlaps the Long Panel Right and it is flush to the side of (439) Rafter Corner Right and a slight overhang at the bottom of the Fascia Beam Assembly. There should be no overhanging at the corners. (F12.3 and F12.4)

G: Attach all panels to Small Roof Rafter Assembly with 33 #8 x 1" Roofing Screws in locations shown in F12.3. Do not place any screws along the bottom row. Be sure not to overtighten screws.

H: Repeat Steps E - G for both Small Roof Rafter Assemblies.

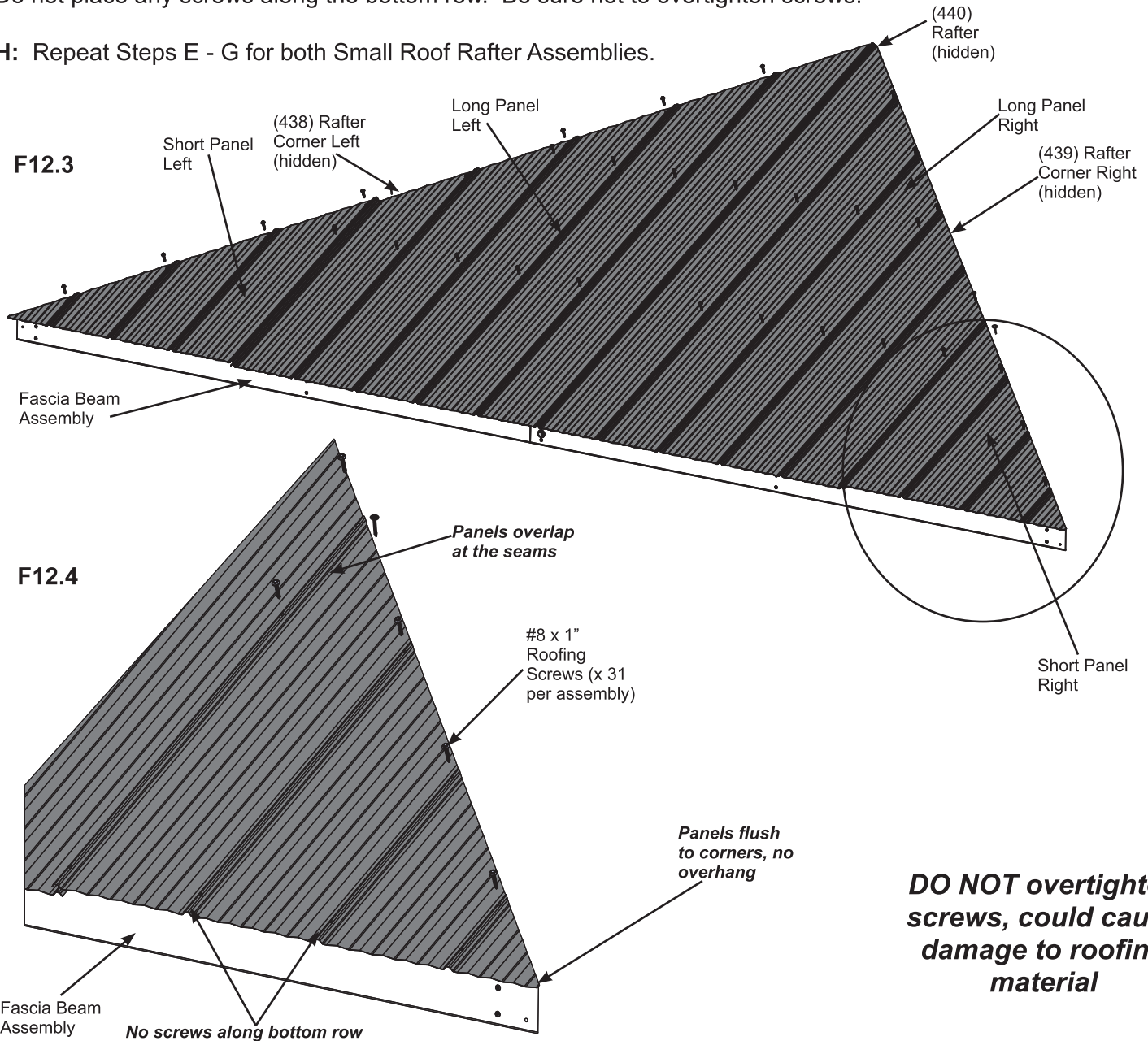

Roof Parts

- 2 x Short Panel Left
- 2 x Short Panel Right

Hardware

- 66 x #8 x 1" Roofing Screw

Step 13: Attach Ridge Clips and Roof Edges - Small Roof



A: Place one Roof Edge Left 72.2 and one Roof Edge Right 72.2 on the bottom of each Small Roof Rafter Assembly so the ends are flush with the outside ends of the Fascia Beam Assembly and meet tight in the centre. Attach both Roof Edges with 17 #8 x 1" Roofing Screws per Small Roof Rafter assembly. (F13.1 and F13.2)

B: Place one Weather Seal on the inside of each Ridge Clip 102.5 then place one Ridge Clip 102.5 on each side of each Small Roof Rafter Assembly so they cover the panels and bottom edge is 2-3/4" (6.99 cm) up from the bottom of the Corner Rafters then attach with five #7 x 3/4" Wood Screws per Ridge Clip 102.5. (F13.1, F13.3 and F13.4)

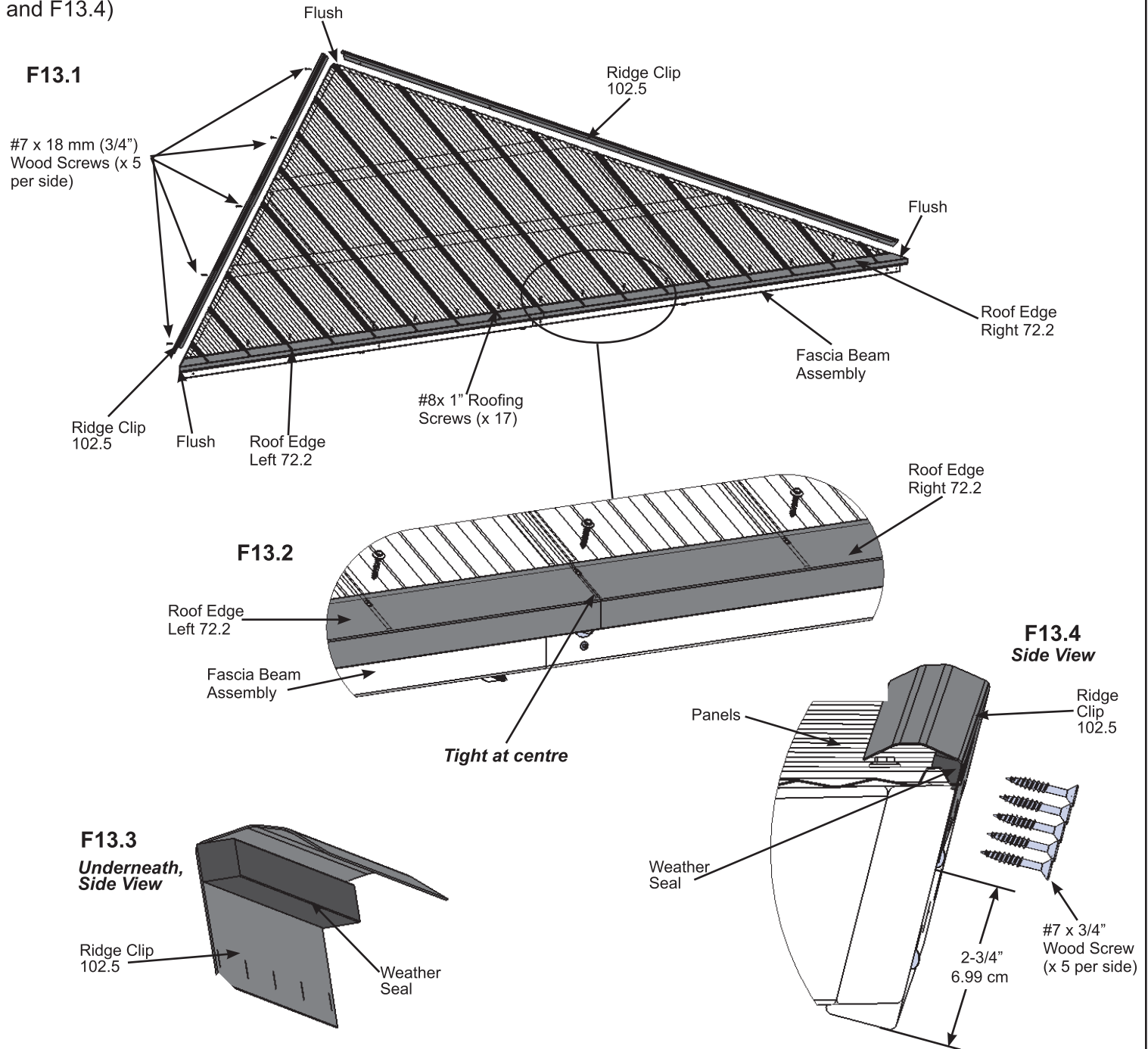

Components:

- 2 x Roof Edge Left 72.2
- 2 x Roof Edge Right 72.2
- 4 x Ridge Clip 102.5
- 4 x Weather Seal

Hardware

- 34 x #8 x 1" Roofing Screw
- 20 x #7 x 3/4" Wood Screw

Step 14: Attach Roof Panels - Large Roof Part 1

A: Place one Middle Panel on the front of one Large Roof Rafter Assembly so it slightly overhangs the top of (434) Top and an overhang at the bottom of the Large Fascia Beam Assembly. Holes should line up with (440) Rafter and (430), (431) and (432) Straps. (F14.1)

B: Place one Long Panel Left and one Long Panel Right on each side of Middle Panel so they overlap the Middle Panel and are flush to the sides of (438) Rafter Corner Left and (439) Rafter Corner Right and an overhang at the bottom of the Large Fascia Beam Assembly. Attach with two #8 x 1" Roofing Screws per panel in the places shown below. Be sure not to overtighten screws. (F14.2)

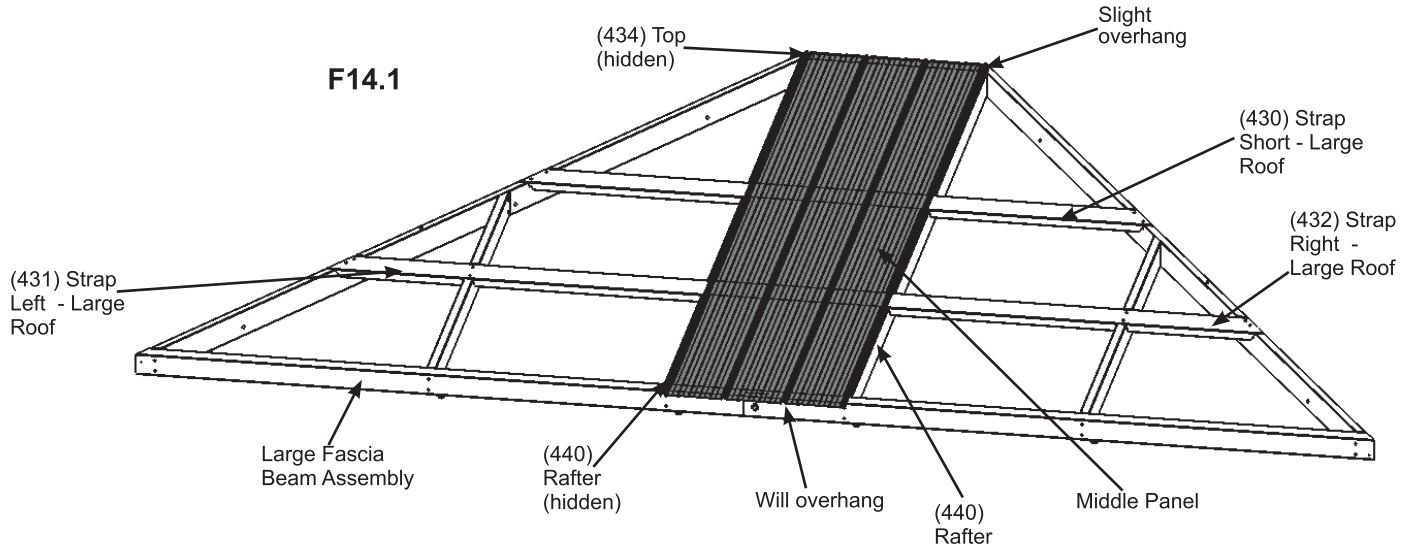

DO NOT overtighten screws, could cause damage to roofing material

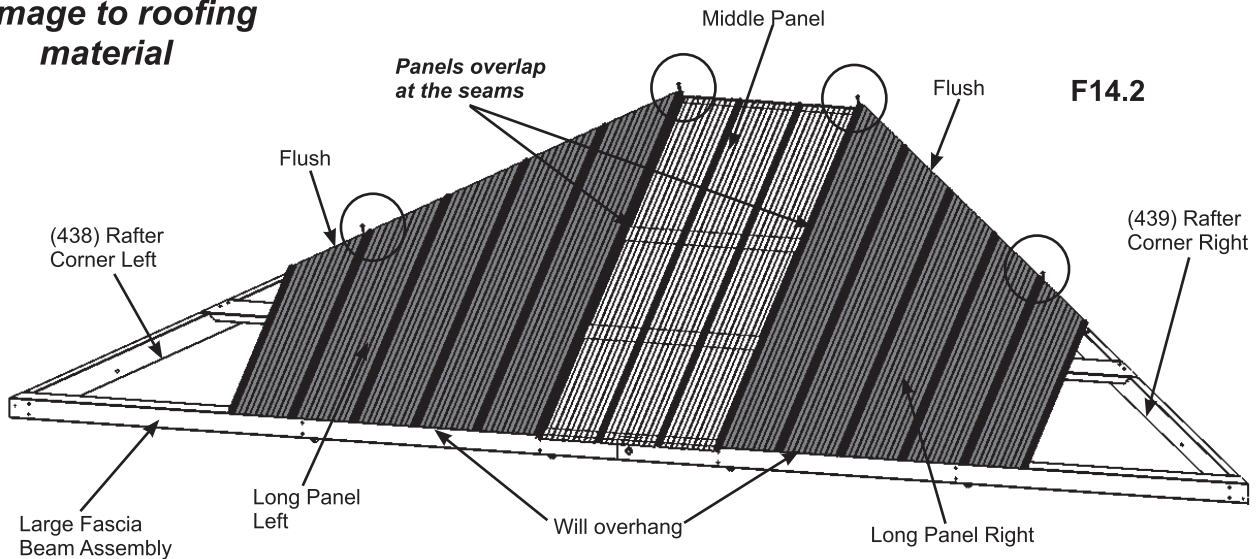

Roof Parts

- 2 x Middle Panel
- 2 x Long Panel Left
- 2 x Long Panel Right

Hardware

- 8 x #8 x 1" Roofing Screw

Step 14: Attach Roof Panels - Large Roof Part 2

C: Place one Short Panel Left so it overlaps the Long Panel Left and it is flush to the sides of (438) Rafter Corner Left and one Short Panel Right so it overlaps the Long Panel Right and it is flush to the side of (439) Rafter Corner Right. There will be a slight overhang at the bottom of the Large Fascia Beam Assembly. There should be no overhang at the corners. (F14.3 and F14.4)

D: Make sure all panels fit properly then attach with 42 #8 x 1" Roofing Screws. Be sure not to overtighten screws. (F14.3 and F14.4)

Notice there are no screws along the bottom row.

E: Repeat Steps A - D for both Large Roof Rafter Assemblies.

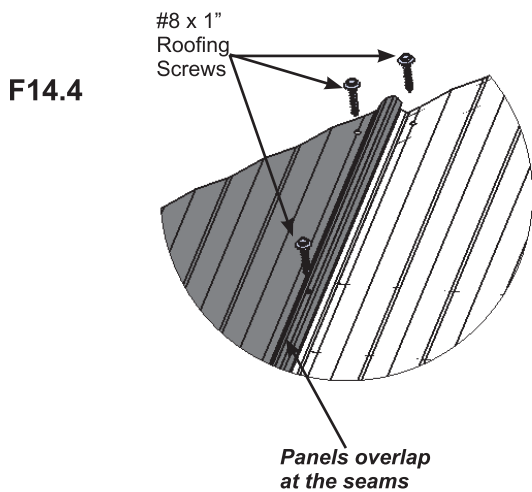
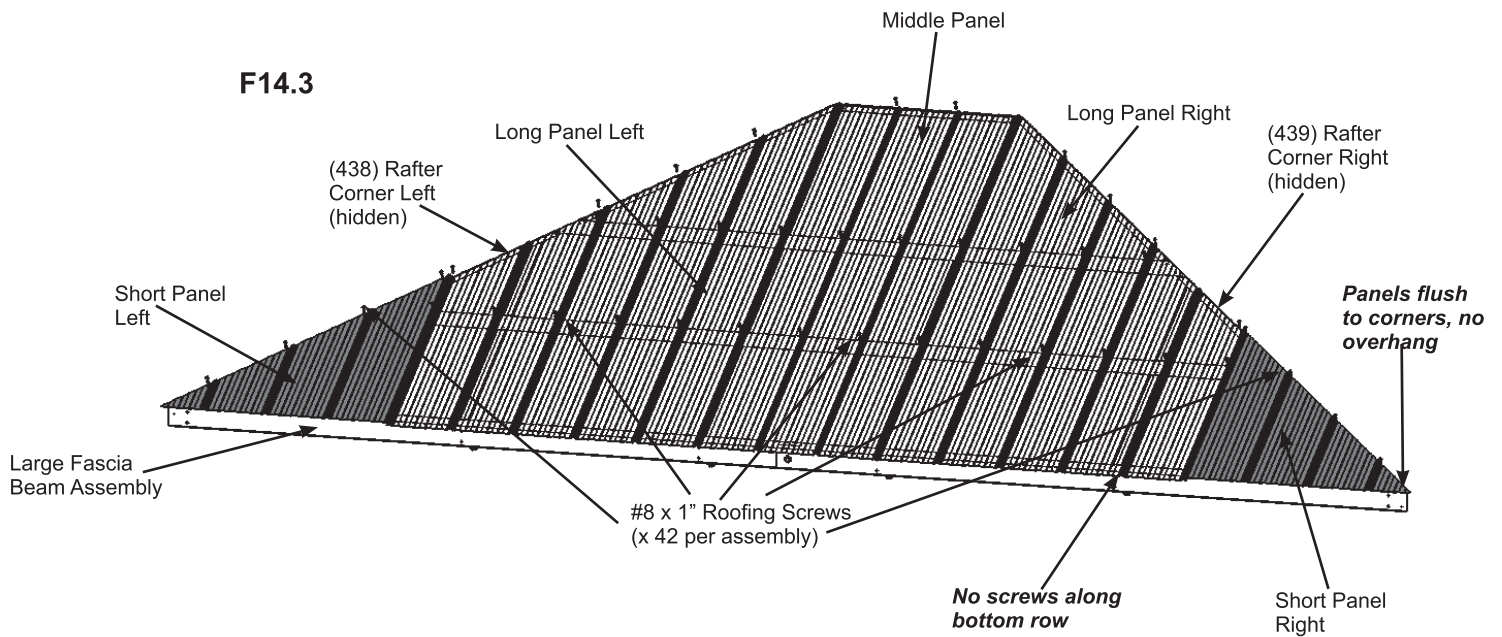

DO NOT overtighten screws, could cause damage to roofing material

Roof Parts

2 x Short Panel Left
2 x Short Panel Right

Hardware

84 x #8 x 1" Roofing Screw

Step 14: Attach Roof Panels - Large Roof Part 3

F: On one Large Roof Rafter Assembly place one (463) Spacer Top flush to the outside edges and centred on (434) Top then attach with three #8 x 2-1/4" Wood Screws. (F14.5 and F14.6)

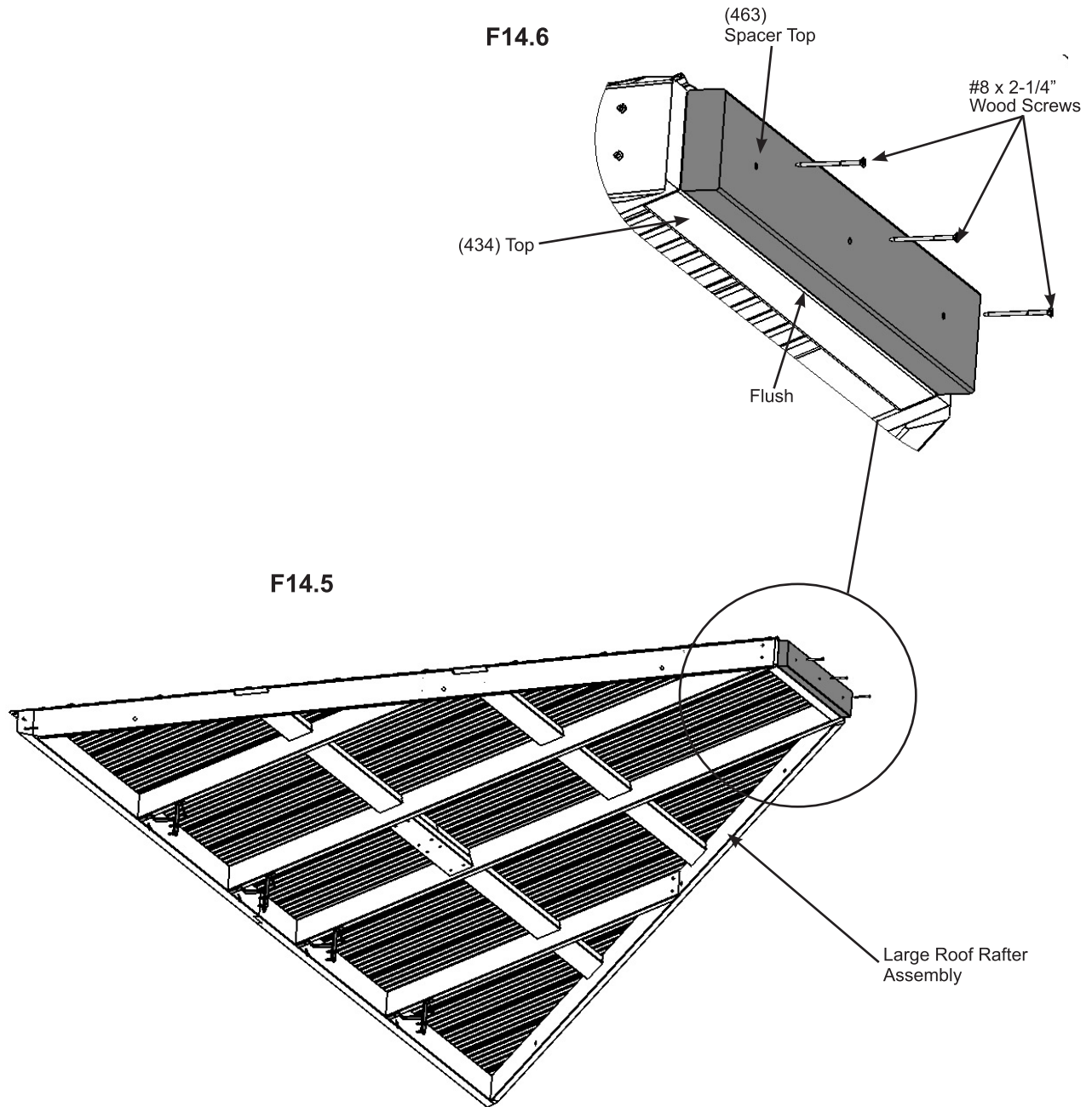

Wood Parts

1 x (463) Spacer Top

Hardware

3 x #8 x 2-1/4" Wood Screws

Step 15: Attach Ridge Clips and Roof Edges - Large Roof



A: Place one Roof Edge Left 72.2 and one Roof Edge Right 96.2 on the bottom of each Large Roof Rafter Assembly so the ends are flush with the outside ends of the Large Fascia Beam Assembly and meet tight in the centre. Attach both Roof Edges with 20 #8 x 1" Roofing Screws per Large Roof Rafter assembly. (F15.1 and F15.2)

B: Place one Weather Seal on the inside of each Ridge Clip 102.5 then place one Ridge Clip 102.5 on each side of each Large Roof Rafter Assembly so they cover the panels and bottom edge is 2-3/4" (6.99 cm) up from the bottom of the Corner Rafters then attach with five #7 x 3/4" Wood Screws per Ridge Clip 102.5. (F15.1, F15.3 and F15.4)

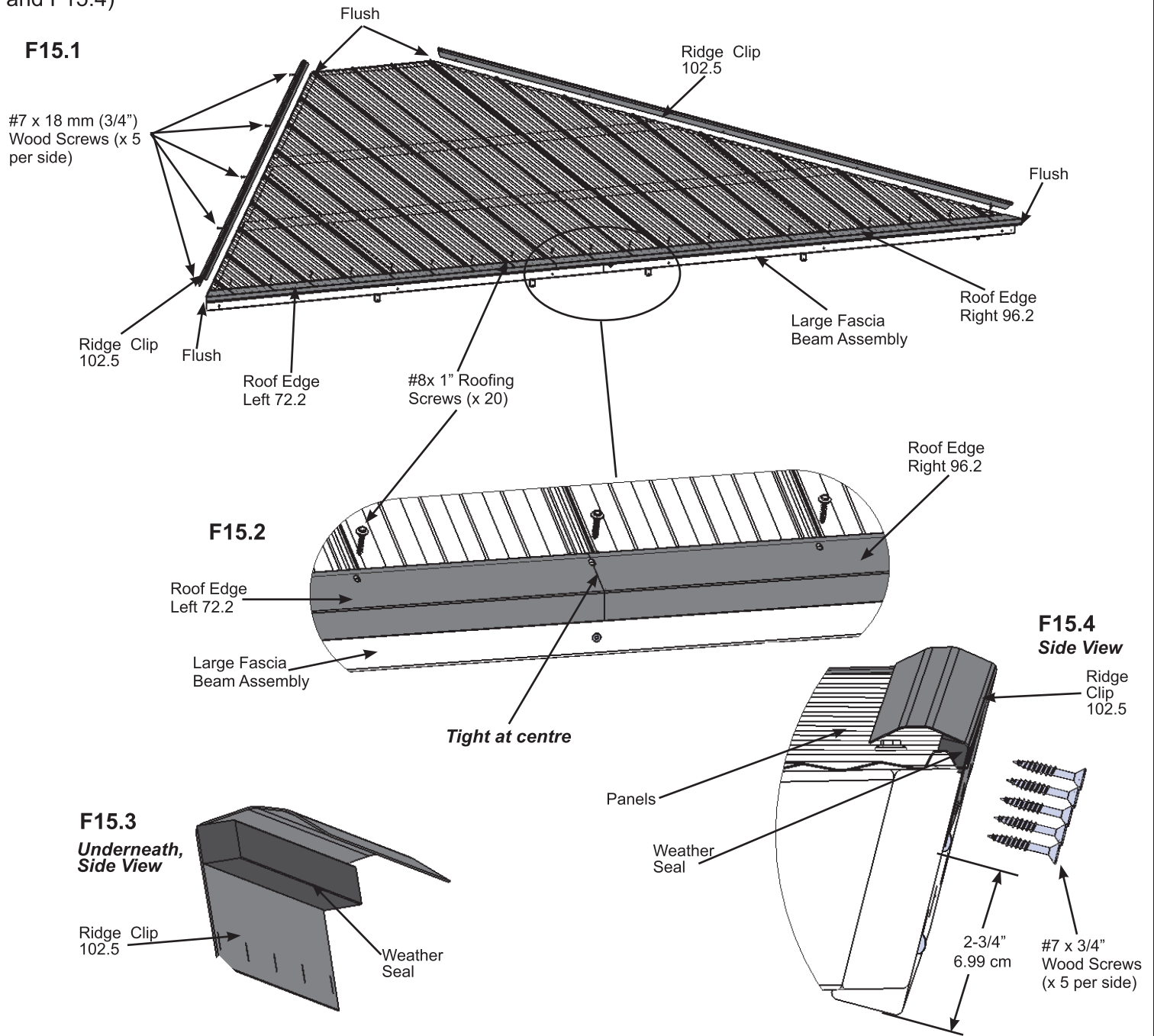

Components:

- 2 x Roof Edge Left 72.2
- 2 x Roof Edge Right 96.2
- 4 x Ridge Clip 102.5
- 4 x Weather Seal

Hardware

- 40 x #8 x 1" Roofing Screw
- 20 x #7 x 3/4" Wood Screw

Step 16: Attach Roof Panels to Frame Part 1

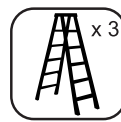

A: From inside the Post Assemblies measure 4' 11-3/16" (1.503m) to mark the centre of each Short Beam Assembly. (F16.1)

B: With all four assemblers place Small Roof Panel Assembly with Roof to Beam Brackets just in front of the Posts then raise it up so it is over Short Beam Assembly, taking care not to drag the panel on the beams. Make sure the middle Roof to Beam Bracket lines up to the centre mark. (F16.1 and F16.2)

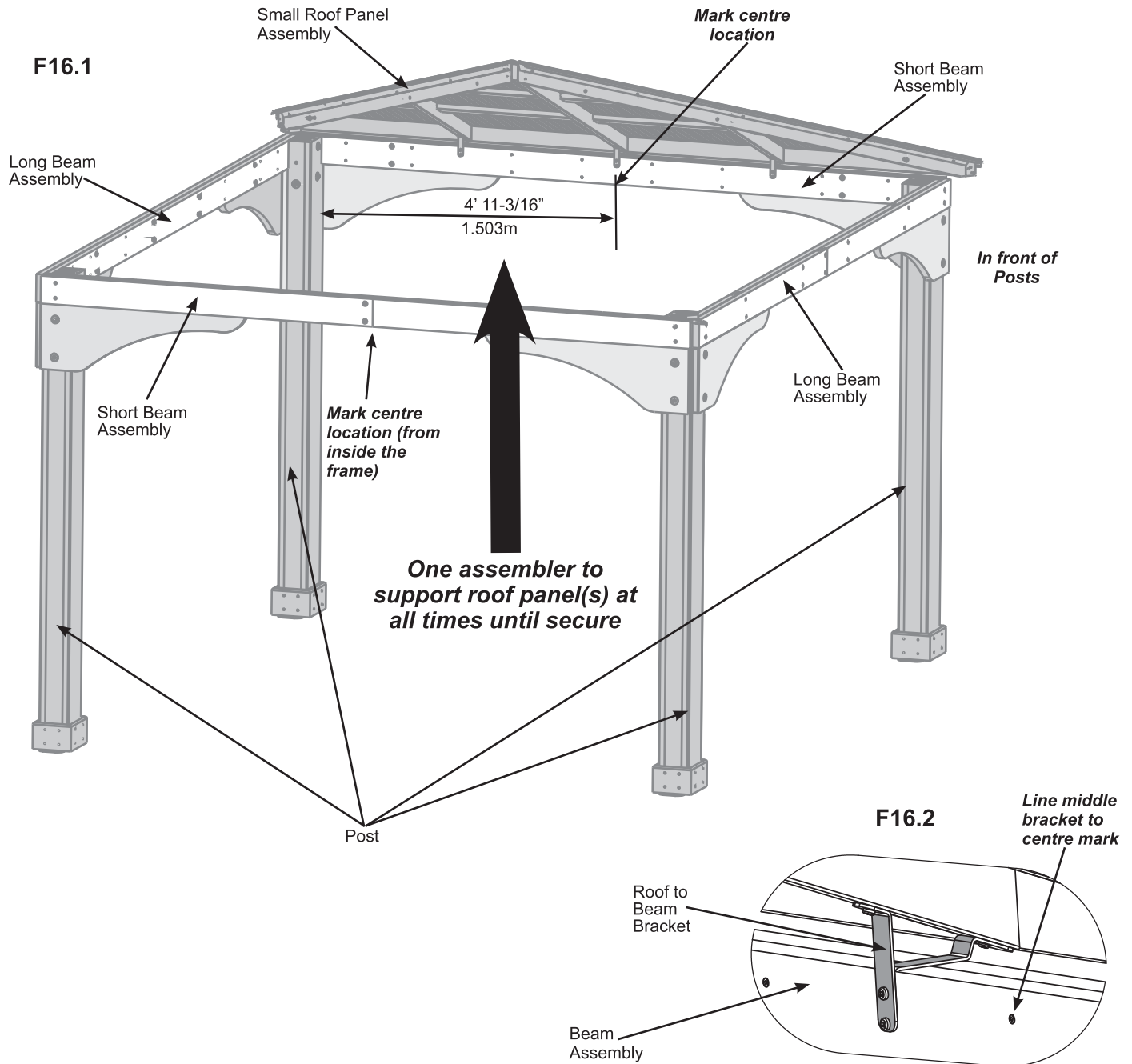

Step 16: Attach Roof Panels to Frame Part 2

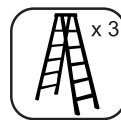

C: Lift a Large Roof Panel Assembly with Roof to Beam Brackets over Long Beam Assembly taking care not to drag the panel on the beams. Make sure the Rafter Corners are flush with each other. **One person must remain on the centre ladder to hold both panels in place until three panels are up and secure.** (F16.3 and F16.4)

D: Starting at the bottom and working up connect Large Roof Panel Assembly to Small Roof Panel Assembly through the Rafter Corners with three 1/4 x 2-3/4" Hex Bolts (with two 1/4-5/16" large washers and one 1/4" lock nut). To align bolt holes helper in the centre may have to push up the centre of the panels while other helpers make sure corners are aligned. Make sure all bolts are tight. (F16.3 and F16.5)

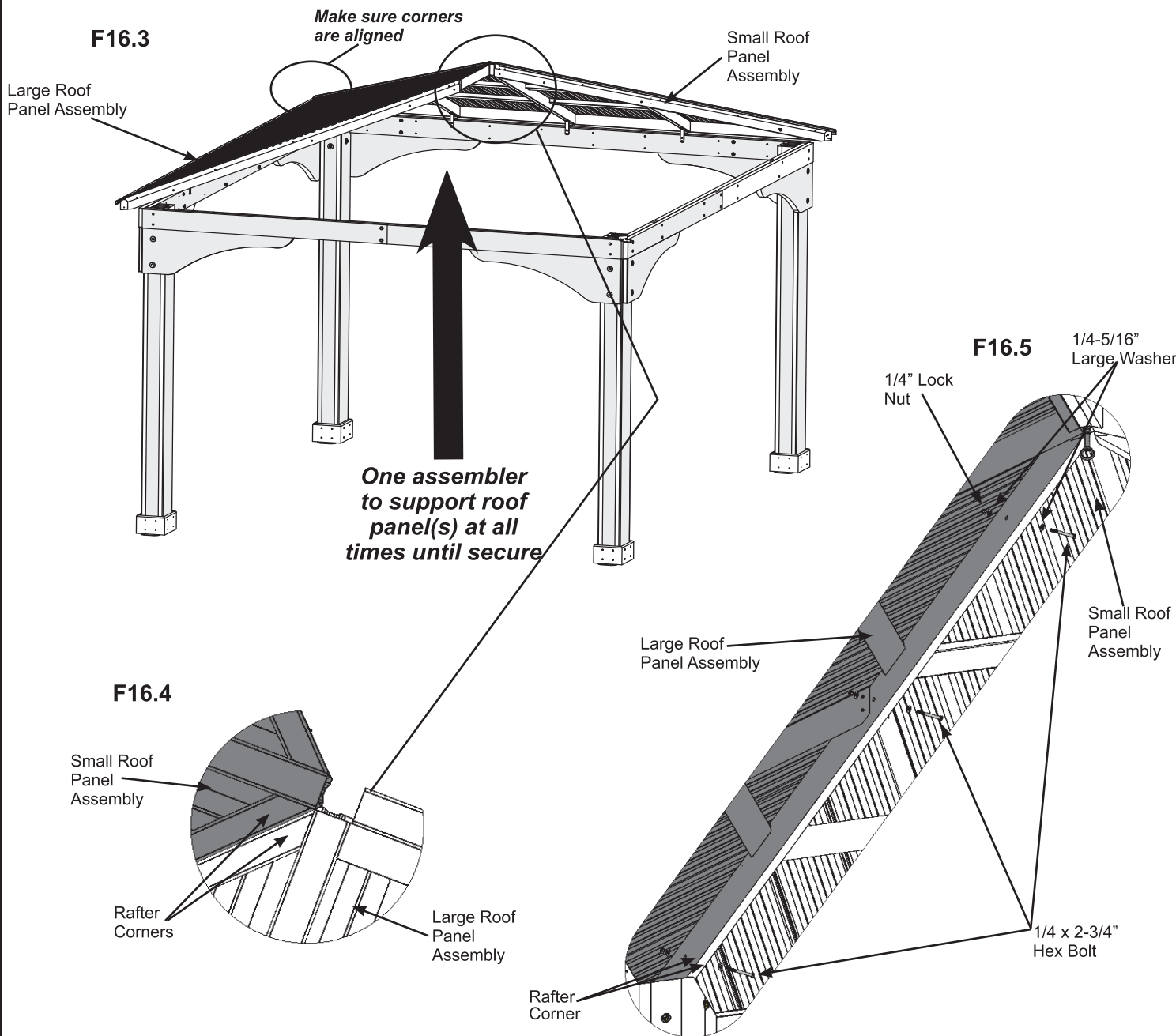

Hardware

3 x 1/4 x 2-3/4" Hex Bolt
(1/4-5/16" large washer x 2, 1/4" lock nut)

Step 16: Attach Roof Panels to Frame Part 3



E: Lift second Large Roof Panel Assembly with Roof to Beam Brackets over Large Beam Assembly taking care not to drag the panel on the beams then set in place beside the Small Roof Panel Assembly. (F16.6)

F: Starting at the bottom and working up connect Large Roof Panel Assembly to Small Roof Panel Assembly through the Rafter Corners with three 1/4 x 2-3/4" Hex Bolts (with two 1/4-5/16" large washers and one 1/4" lock nut). To align bolt holes helper on the centre ladder may have to push up in the centre of the panels and others make sure corners are aligned. Make sure all bolts are tight. (F16.7)

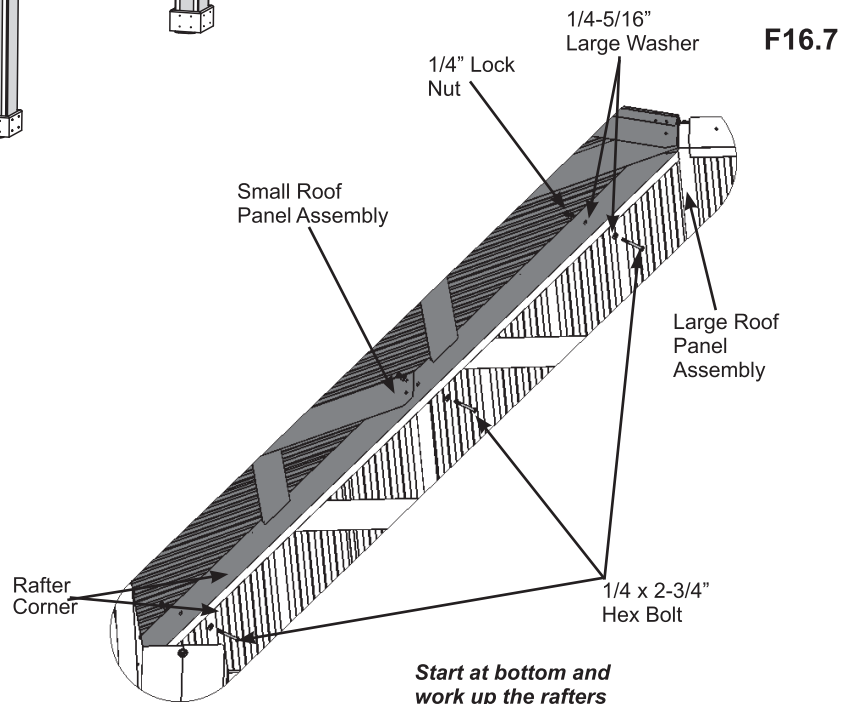
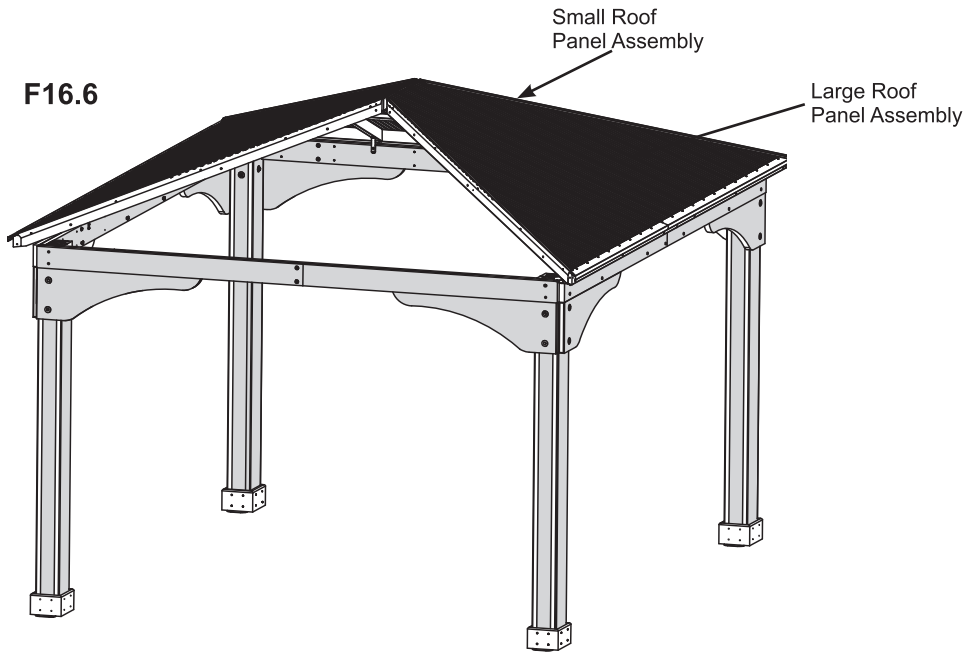

Hardware

3 x 1/4 x 2-3/4" Hex Bolt
(1/4-5/16" large washer x 2, 1/4" lock nut)

Step 17: Roof Peak Assembly

A: Insert two Carriage Bolts with Contoured Washers through the top of Peak Cap Long, into Peak Post then Spring Clip. The Spring Clip holds the assembly together. (F17.1)

B: Insert one 1/4" Nut into each Peak Loop. Be careful nut is loose and will fall out until attached to Peak Cap Assembly. (F17.2)

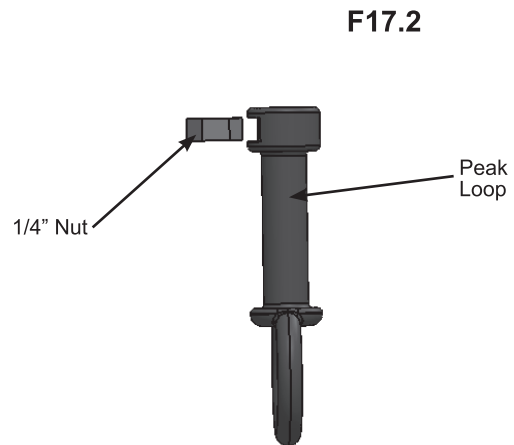
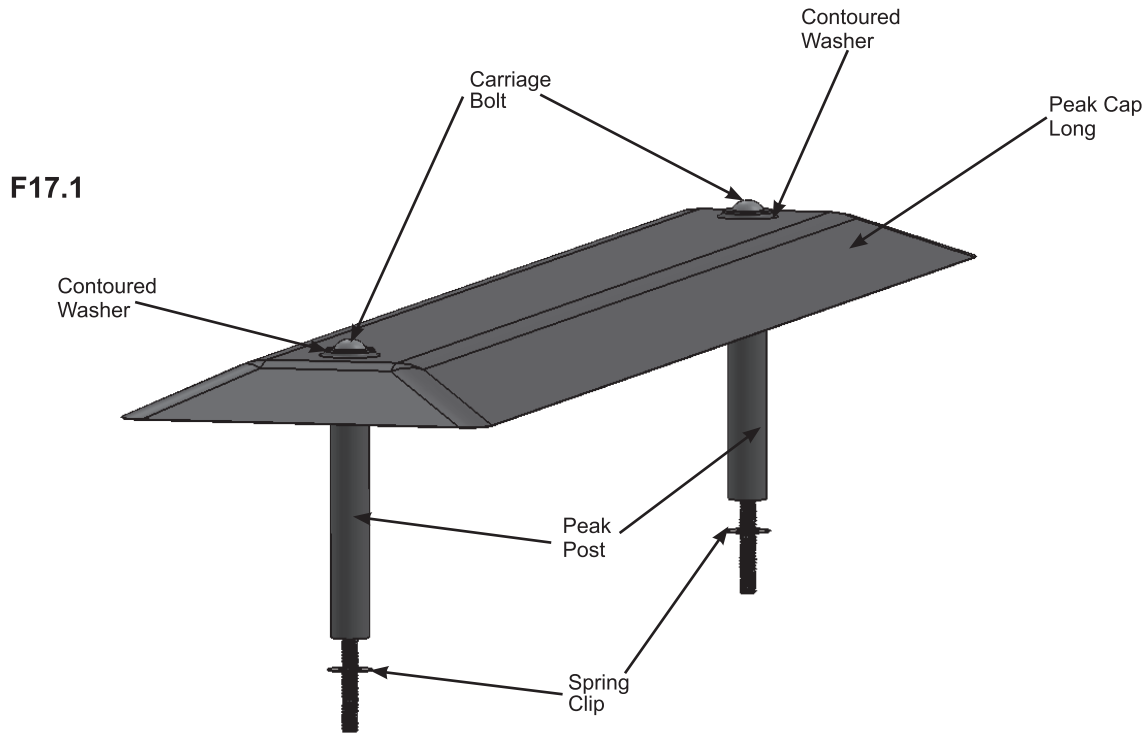

Components:

1 x Roof Peak Set	1 x Peak Cap Long
2 x Carriage Bolt	2 x Peak Post
2 x Contoured Washer	
2 x Peak Loop	
2 x Spring Clip	
2 x 1/4" Nut	

Step 18: Attach Roof Peak to Roof Panels



A: Insert Roof Peak Assembly in gap between Large and Small Roof Panels. Peak Cap Long to be lined up with Rafter Corners. (F18.1 and F18.2)

B: Insert two Roof Peak Brackets through each Carriage Bolt and attach Peak Loop to Carriage Bolts then twist to tighten loosely.

C: Loosely attach one set of Roof Peak Brackets to the Rafter Corners of the connected Large and Small Roof Panels in the slotted holes with four #10 x 1-1/4" Pan Screws. On the second set of Roof Peak Brackets loosely attach to the Rafter Corners of Large Roof Panels with two #10 x 1-1/4" Pan Screws. (F18.3)

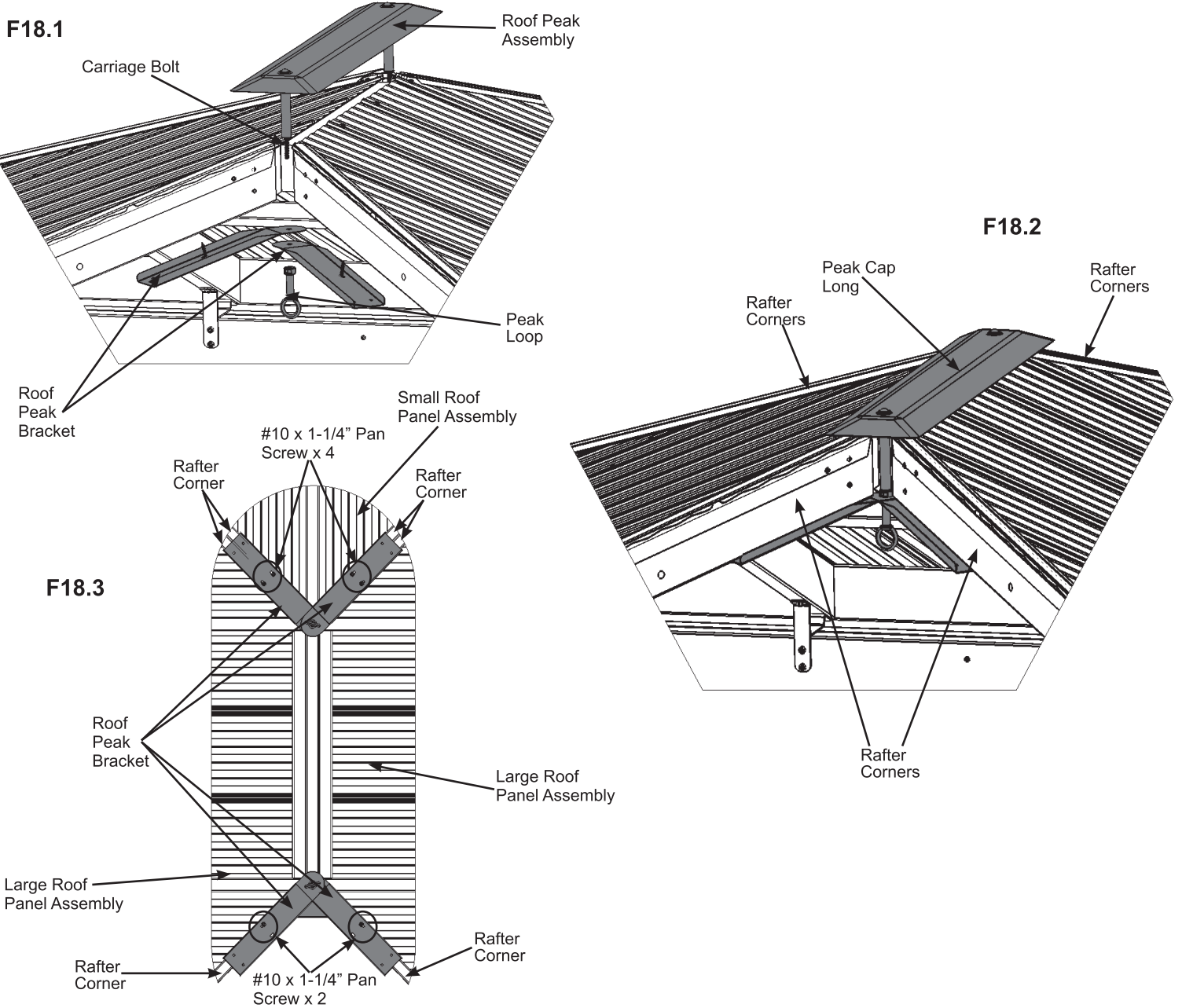

Components:

4 x Roof Peak Brackets

Hardware

6 x #10 x 1-1/4" Pan Screw

Step 19: Attach Final Roof Panel Part 1

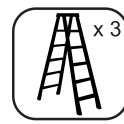

A: Lift last Small Roof Panel Assembly (without Roof to Beam Brackets) over Short Beam Assembly taking care not to drag the panel on the beams. Panel fits under the Peak Cap Long, push up on Peak Loop to lift Peak Cap Long. The centre of the other panels may have to be pushed up to fit fourth panel. (F19.1 and F19.2)

F19.1

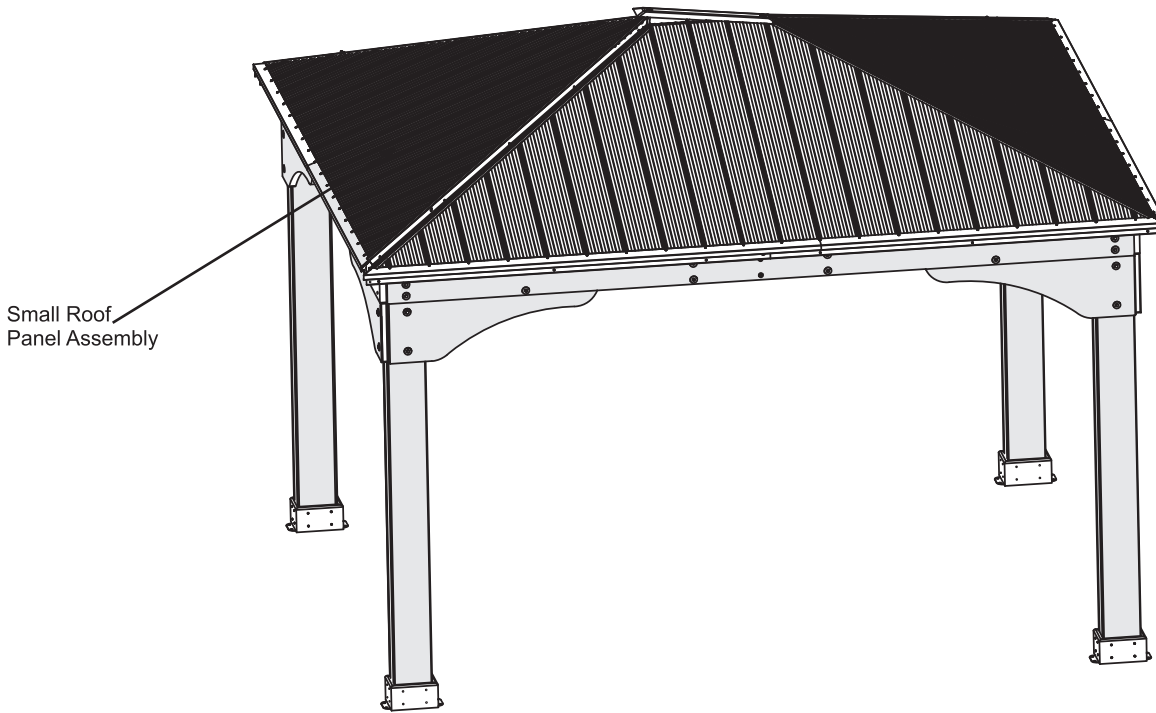

F19.2

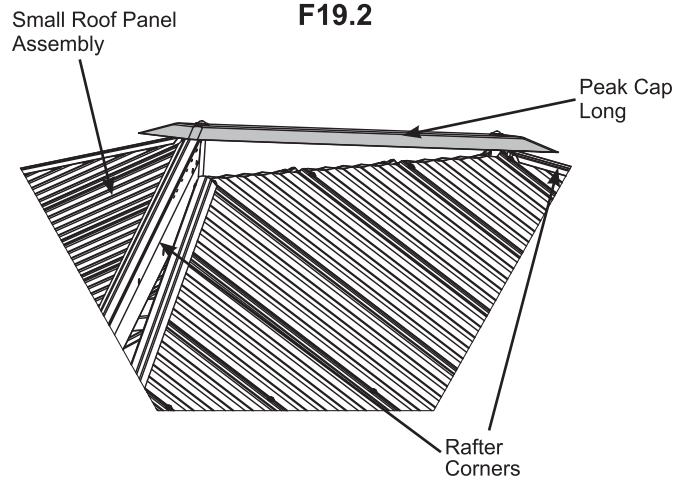

Step 19: Attach Final Roof Panel Part 2

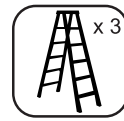

Remember to push up centre to assist with alignment.

B: Starting at the bottom and working up loosely connect Roof Panel Assemblies through the Rafter Corners with three 1/4 x 2-3/4" Hex Bolts (with two 1/4-5/16" large washers and one 1/4" lock nut) per side. To align bolt holes helper on the centre ladder may have to push up in the centre of the panels and others make sure corners are aligned. Tighten bolts when all six have been installed. (F19.3 and F19.4)

Rafter Corners should be aligned with Roof to Post Bracket.

F19.3

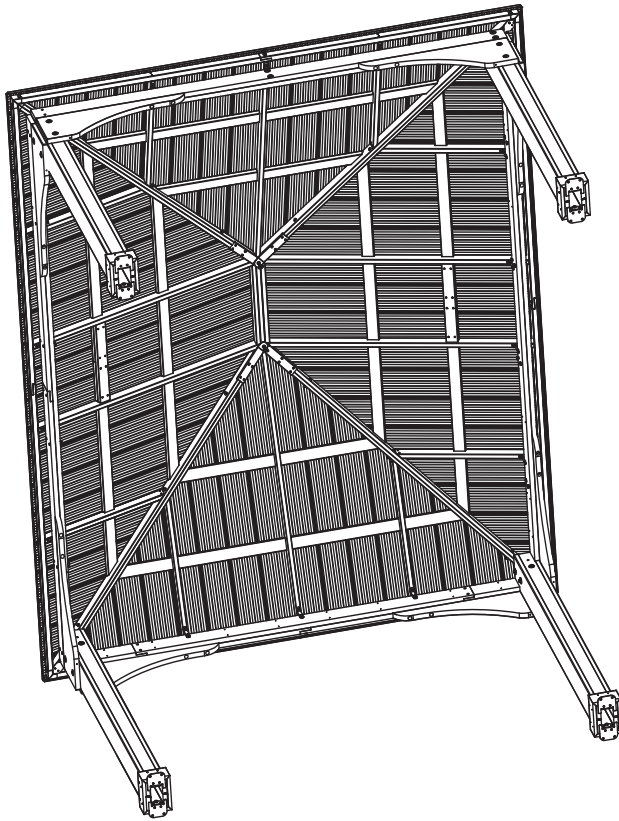

F19.4

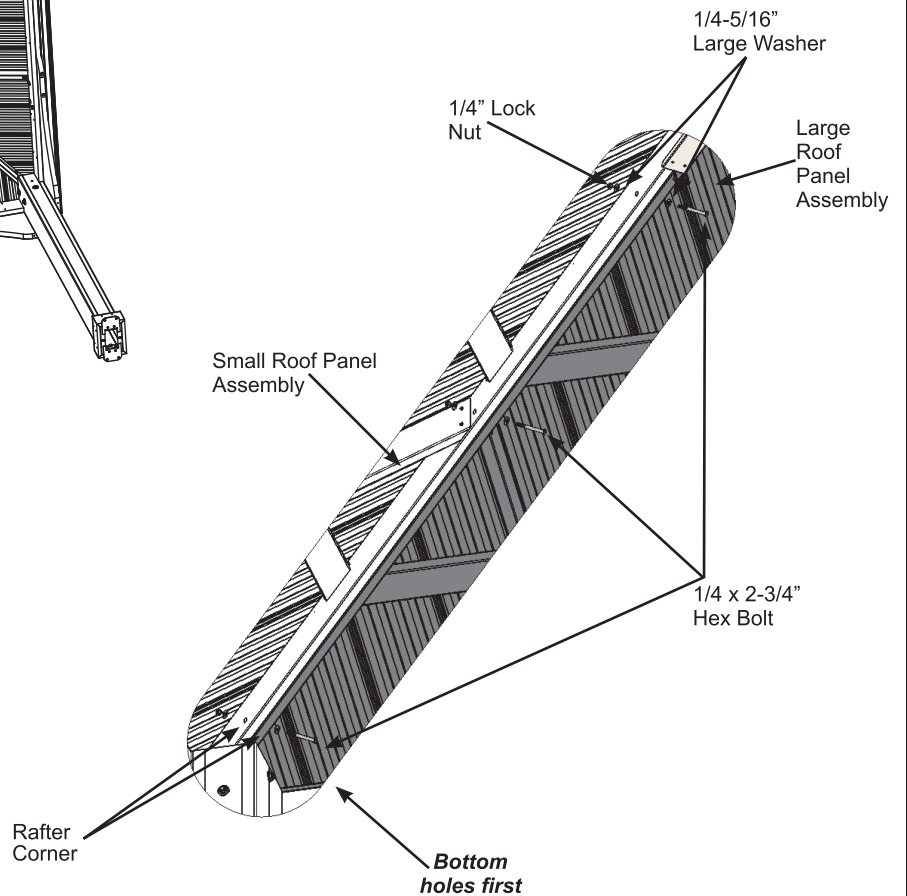

Hardware

6 x 1/4 x 2-3/4" Hex Bolt
(1/4-5/16" large washer x 2, 1/4" lock nut)

Step 19: Attach Final Roof Panel Part 3

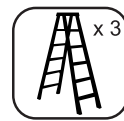

C: On the Small Roof Rafter Assembly just installed, centred on the bottom of (442) Rafter Short Right, (441) Rafter Short Left and (440) Rafter attach one Roof to Beam Bracket per board with one #8 x 1" Pan Screw in the bottom hole and one #12 x 1-1/2" Pan Screw in the top hole per bracket. (F19.5)

F19.5

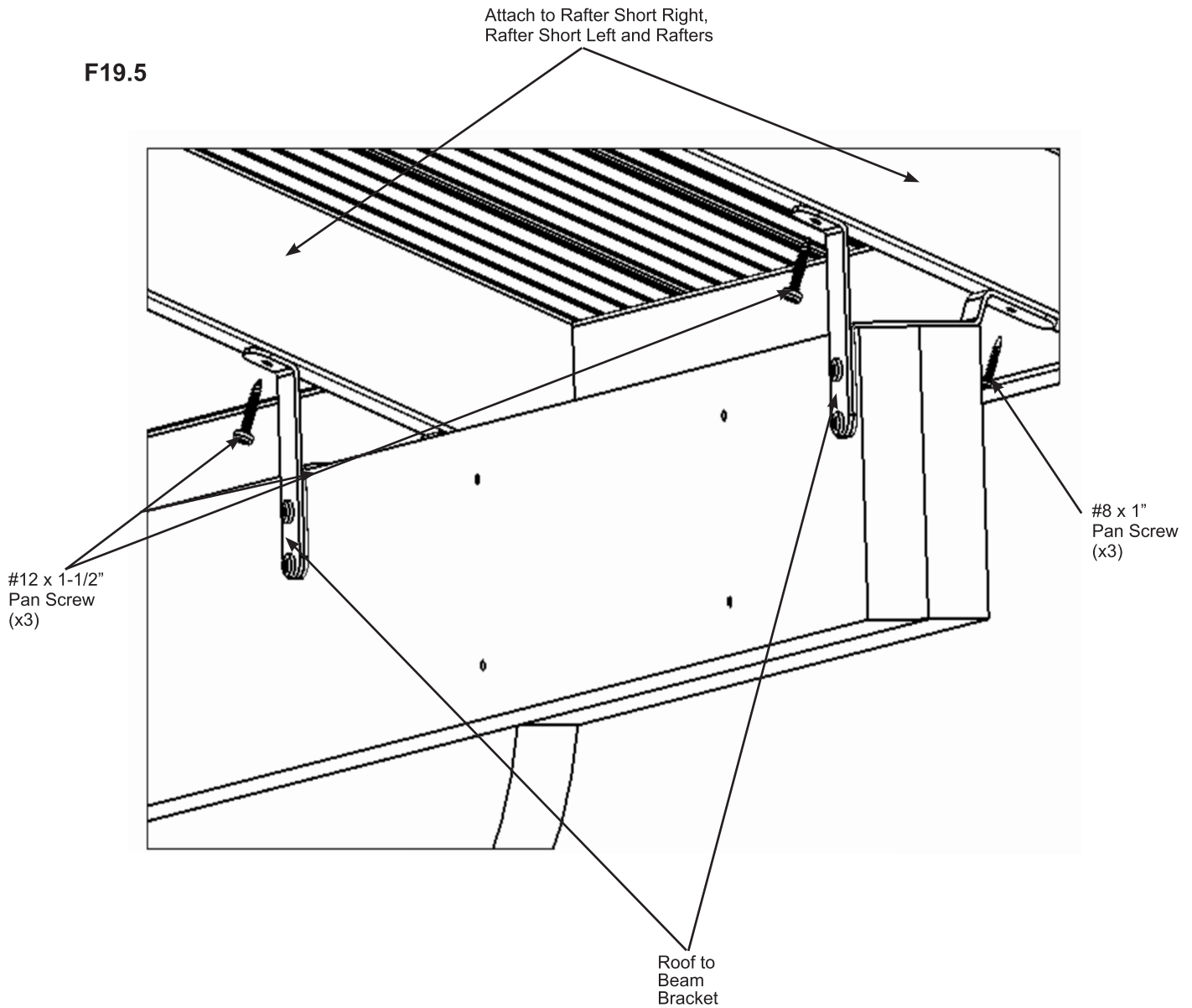

Components

3 x Roof to Beam Bracket

Hardware

3 x #8 x 1" Pan Screw

3 x #12 x 1-1/2" Pan Screw

Step 20: Secure Roof Corners

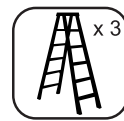

A: Make sure middle Roof to Beam Brackets are flush and tight to the Beam Assemblies. Lift in centre if needed.

B: From outside the assembly attach Roof Panel Assemblies together at the Fascia Beam Assembly Ends with two #8 x 2-1/2" Wood Screws per corner. A helper may need to lift the centre of the roof to bring the corners tight together. (F20.1 and F20.2)

C: Align Roof Panel Assemblies to sit centred on Rafter to Post Brackets then attach with two #8 x 1" Pan Screws per bracket. (F20.2)

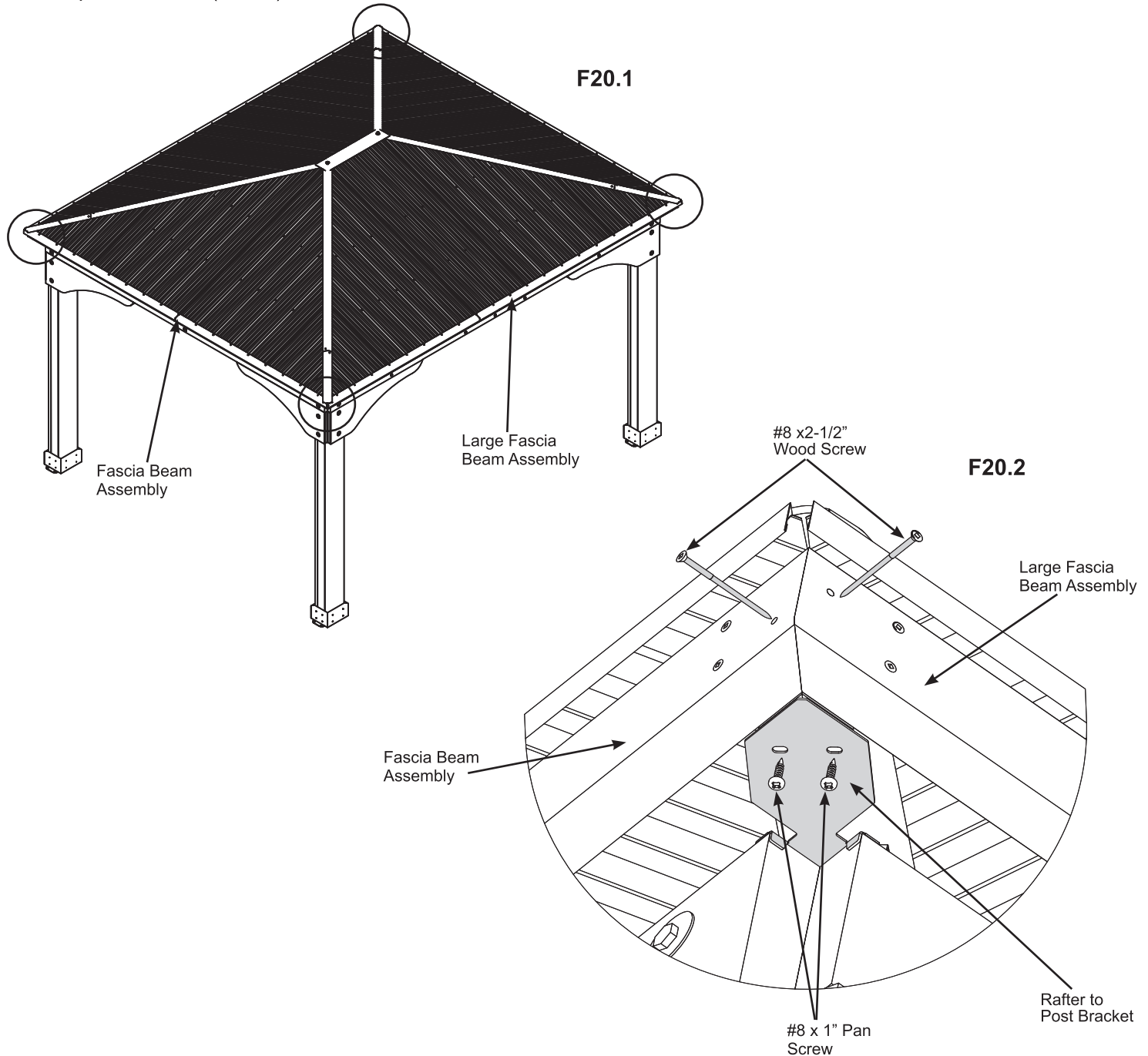

Hardware

8 x #8 x 2-1/2" Wood Screw

8 x #8 x 1" Pan Screw

Step 21: Attach Corner and Beam Caps

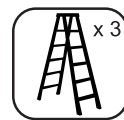

A: At each corner place one Corner Cap tight to Fascia Assemblies, push up so the bottom is tight to the bottom of the assemblies then attach with four #8 x 3/4" Sheet Metal Screws per Corner Cap. (F21.1 and F21.2)

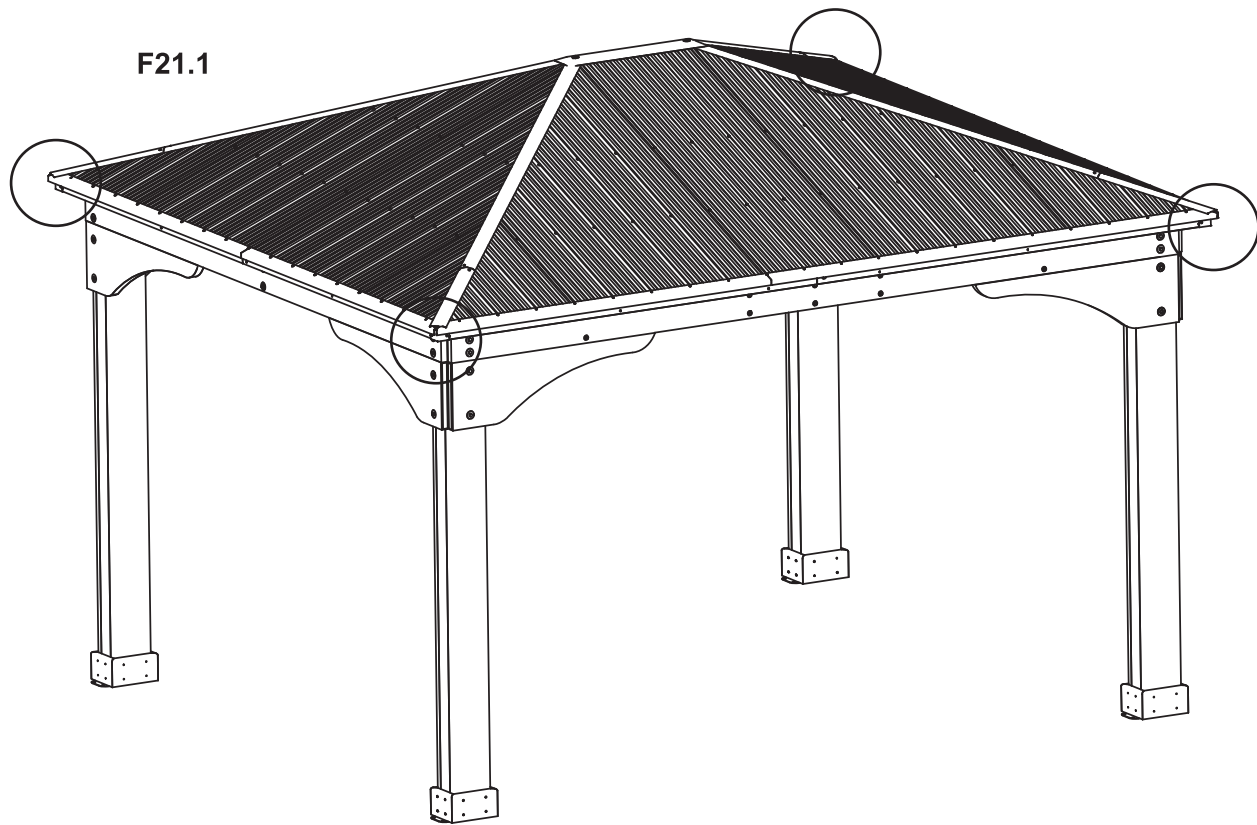

F21.1

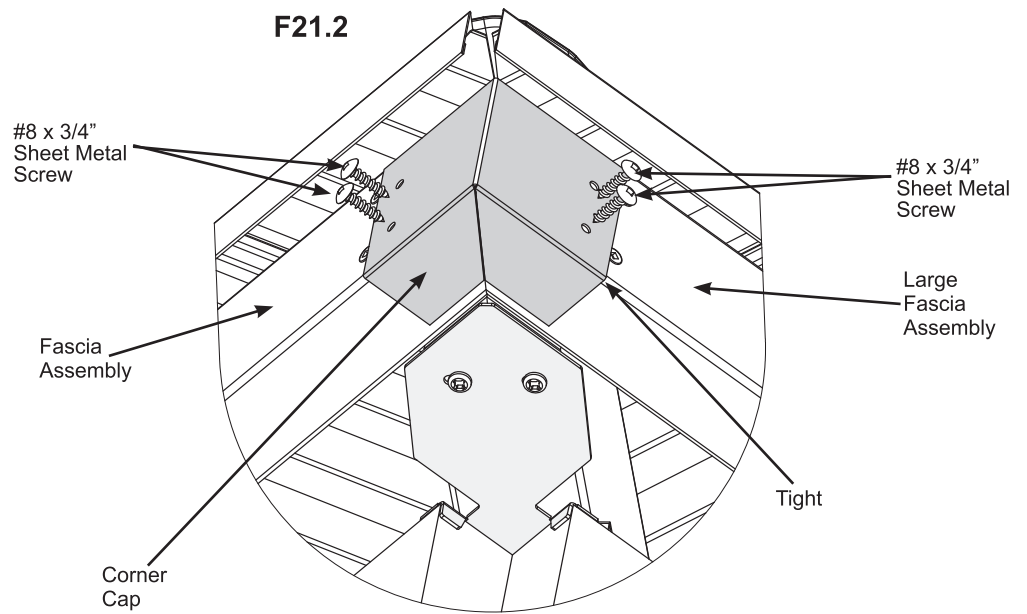

F21.2

Components:

4 x Corner Cap

Hardware

16 x #8 x 3/4" Sheet Metal Screw

Step 22: Secure Roof to Beam Brackets

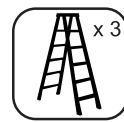

A: From inside the assembly attach Roof to Beam Brackets to Beam Assemblies with two #12 x 1-1/2" Pan Screw per bracket. (F22.1 and F22.2)

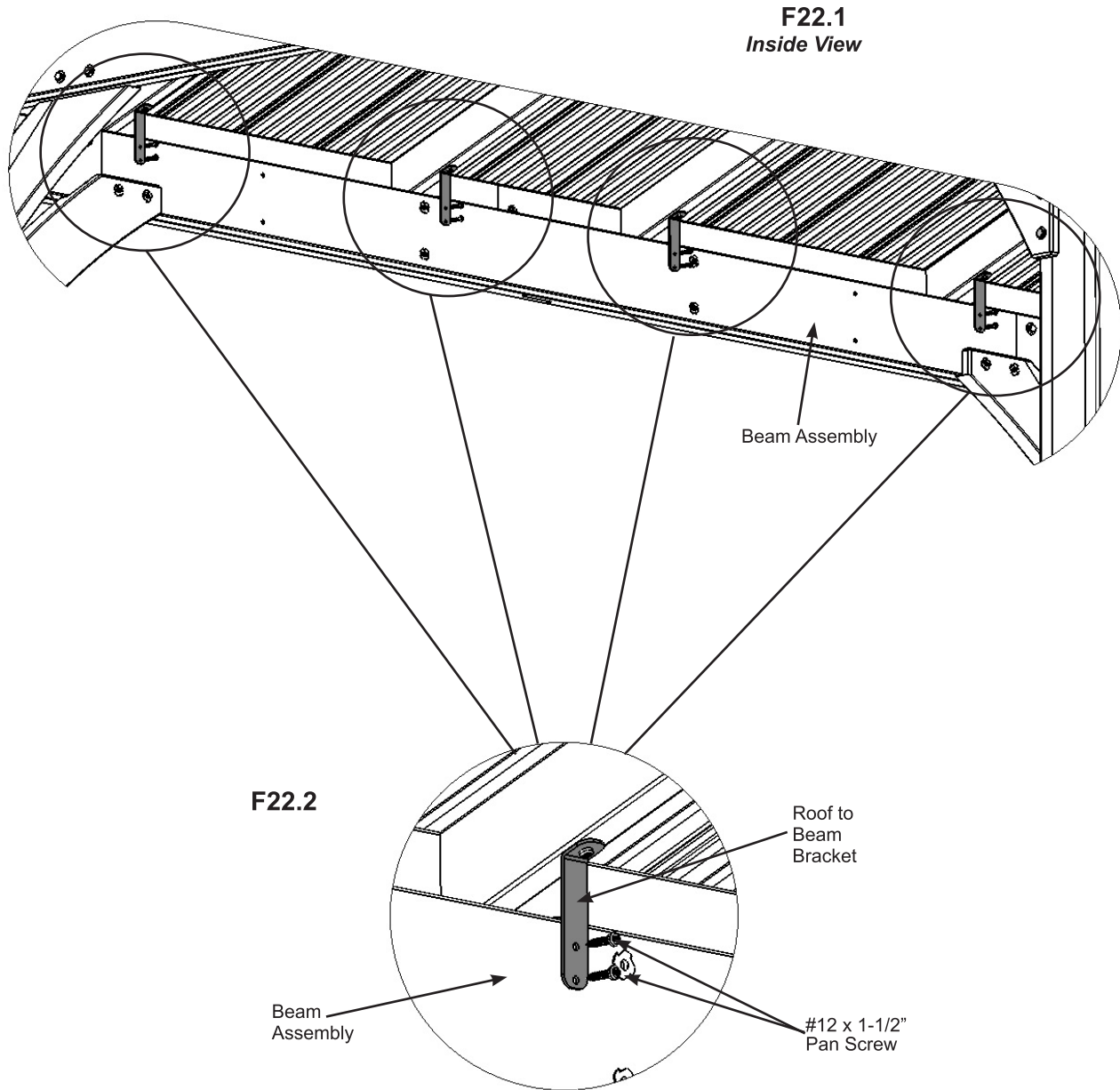

Hardware

28 x #12 x 1-1/2" Pan Screw

Step 23: Secure Roof Peak Brackets



A: Tighten the six screws in Roof Peak Brackets then attach to Corner Rafters in the remaining holes with ten #10 x 1-1/4" Pan Screws. (F23.1)

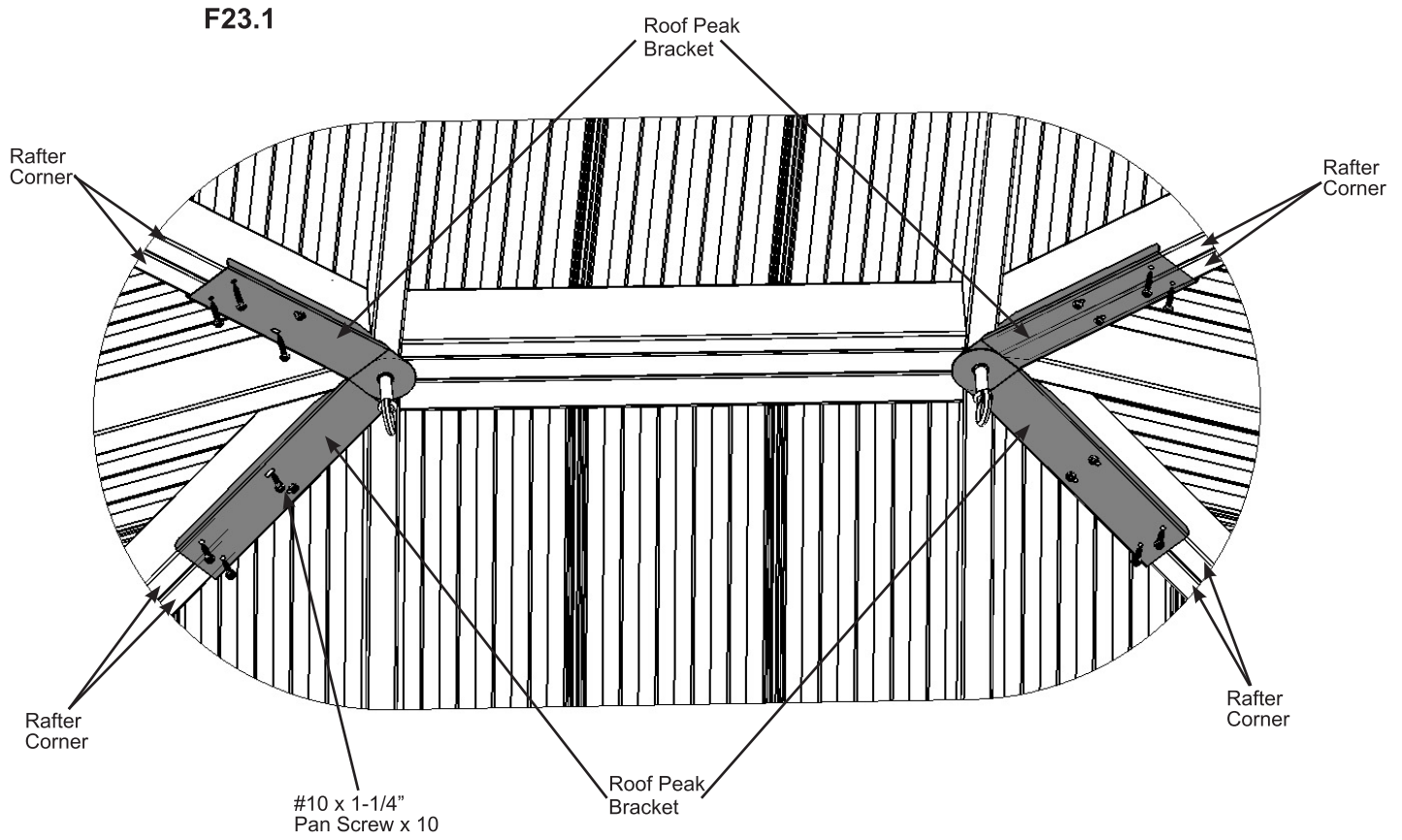

Hardware

10 x #10 x 1-1/4" Pan Screw

Step 24: Attach Ridge Caps to Roof Panels

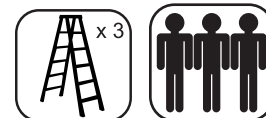

A: Slide one Ridge Cap Long 81.5 over the Ridge Clips, with cut end leading, on each corner of the assembly from the bottom up. Slide Ridge Cap Short 25.2 over the Ridge Clips leading with the insert end to push the Ridge Cap Long 81.5 to the top, lifting Peak Cap Long by pushing up the Peak Loop so Ridge Cap Long 81.5s fit under Peak Cap Long. Attach with two #8 x 3/4" Sheet Metal Screws per Ridge Cap set. (F24.1, F24.2, F24.3, F24.4 and F24.5)

B: Tighten Loop to secure Roof Peak Set.

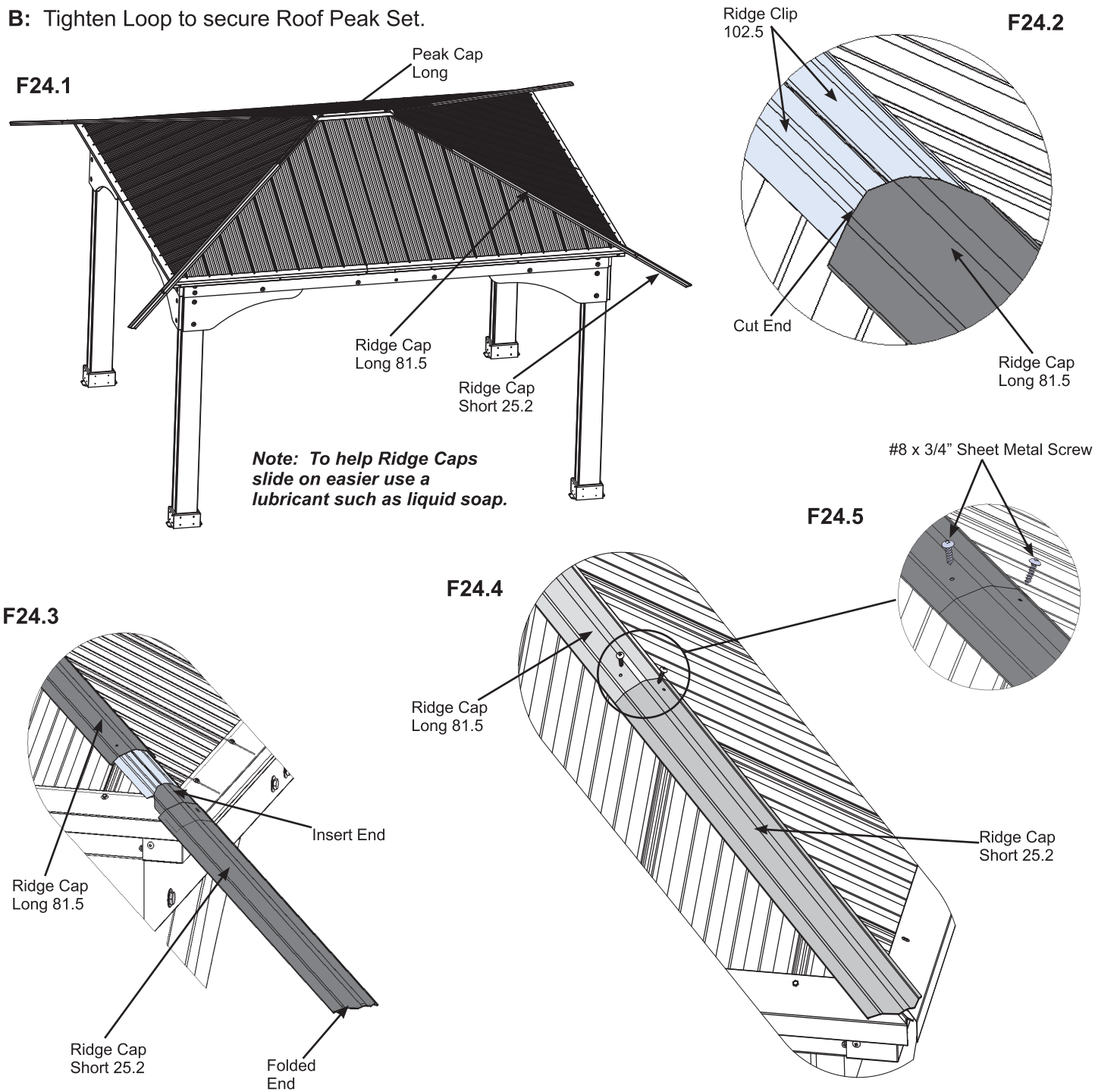

Components:

- 4 x Ridge Cap Long 81.5
- 4 x Ridge Cap Short 25.2

Hardware

- 8 x #8 x 3/4" Sheet Metal Screw

Step 25: Attach Tie Wrap Brackets and Ties

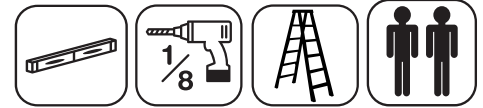

A: Attach one Tie Wrap Bracket to each end of one (461) Tie with one #10 x 1-1/4" Pan Screw per bracket using the inside holes. (461) Tie is tight to end of bracket. (F25.1, F25.2 and F25.3)

B: With a helper place (461) Tie with brackets against a (440) Rafter on each Large Roof Panel so (461) Tie is tight to (440) Rafters and level. Attach Tie Wrap Bracket to (440) Rafters with two #10 x 1-1/4" Pan Screws on both sides of each bracket. (F25.1, F25.2 and F25.3)

C: Pre-drill with a 1/8" drill bit and secure Tie Wrap Brackets to (461) Tie and (440) Rafter with one #10 x 2-1/2" Pan Screw per bracket. (F25.1, F25.2 and F25.3)

D: Repeat Steps A to C for a second (461) Tie.

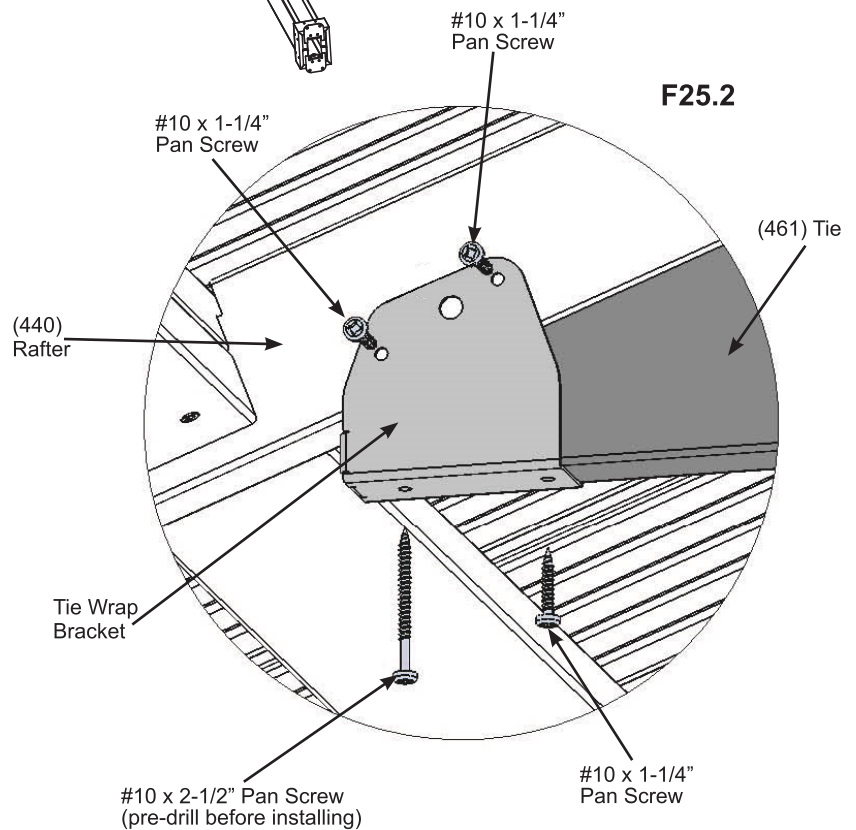
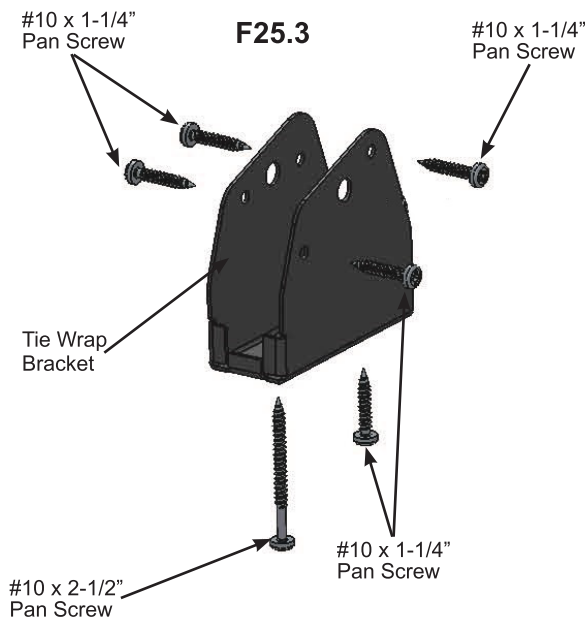
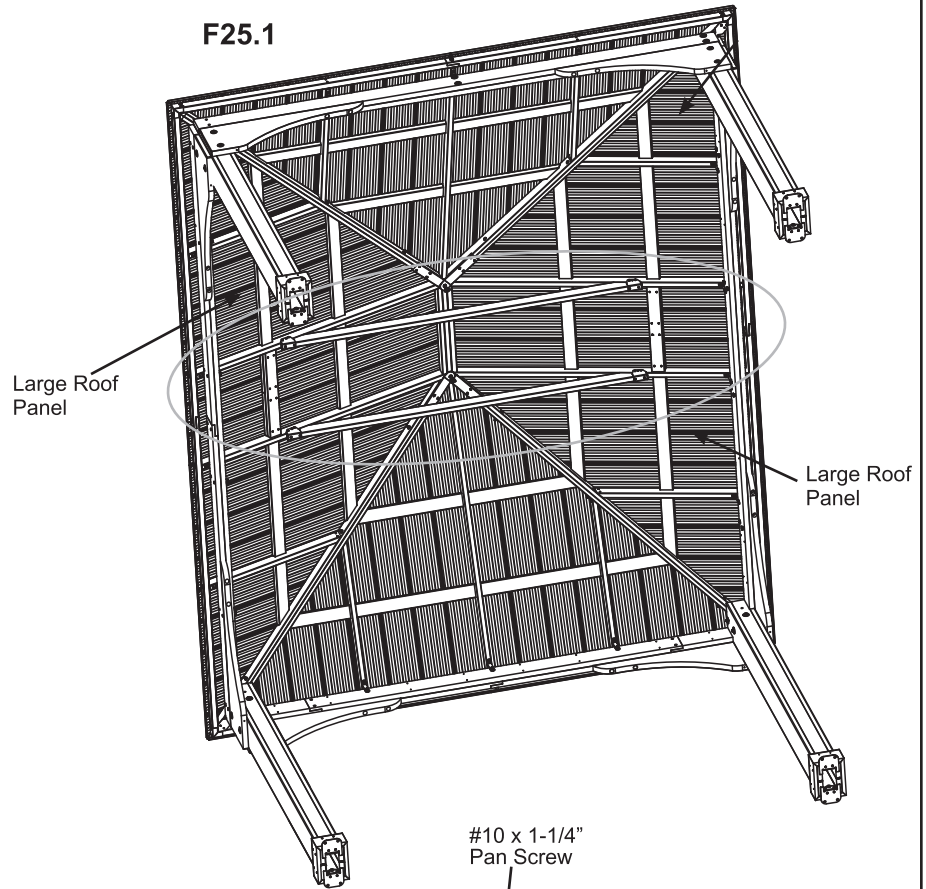

Wood Parts

2 x (461) Tie

Components:

4 x Tie Wrap Bracket

Hardware

20 x #10 x 1-1/4" Pan Screw
4 x #10 x 2-1/2" Pan Screw

Step 26: Attach Twist Brackets



A: Measure 3-3/4" (9.53 cm) down from the inside of each post, place bottom of either 45° Twist Bracket LT or 45° Twist Bracket RT at measured location then attach to post and Corner Rafter (Left or Right) with four #12 x 1-1/2" Pan Screws per bracket. (F26.1 and F26.2)

F26.1

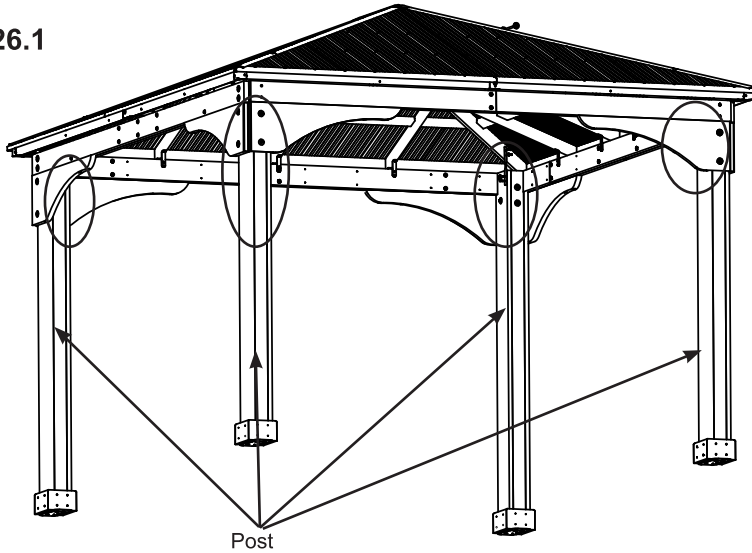

Note: Twist Brackets will bend when attaching, this is normal so they sit tight against rafters and posts.

F26.2

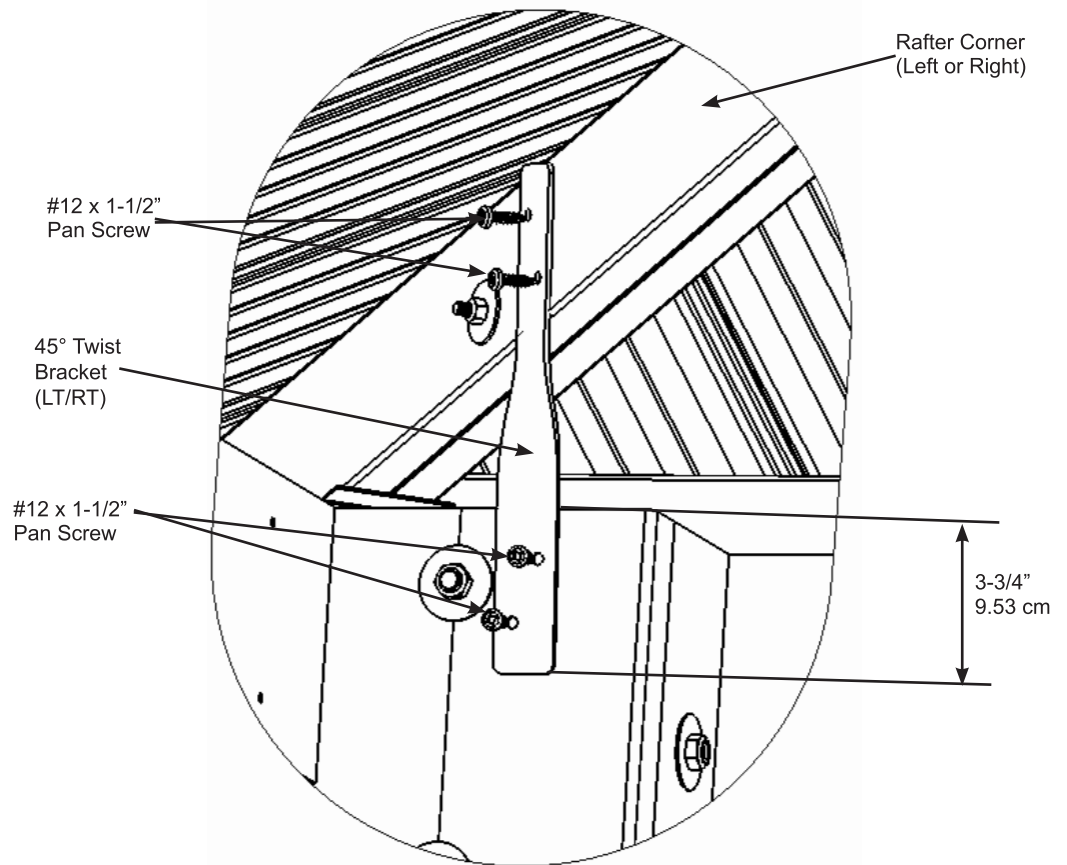

Components:

- 2 x 45° Twist Bracket LT
- 2 x 45° Twist Bracket RT

Hardware

- 16 x #12 x 1-1/2" Pan Screw

Step 27: Metal Hooks and Plaque Part 1



A: Two 50 mm Hooks are included with this unit for attaching wiring. They can be placed anywhere along the Rafter Corners as needed. Pre-drill with a 1/8" drill bit before installing. (F27.1 and F27.2)

B: One Eye Lag is included with this unit for hanging items with a maximum weight of 22 lbs (10 kg). Pre-drill with a 1/8" drill bit into centre of (463) Spacer Top then install Eye Lag. (F27.1 and F27.3)

F27.1

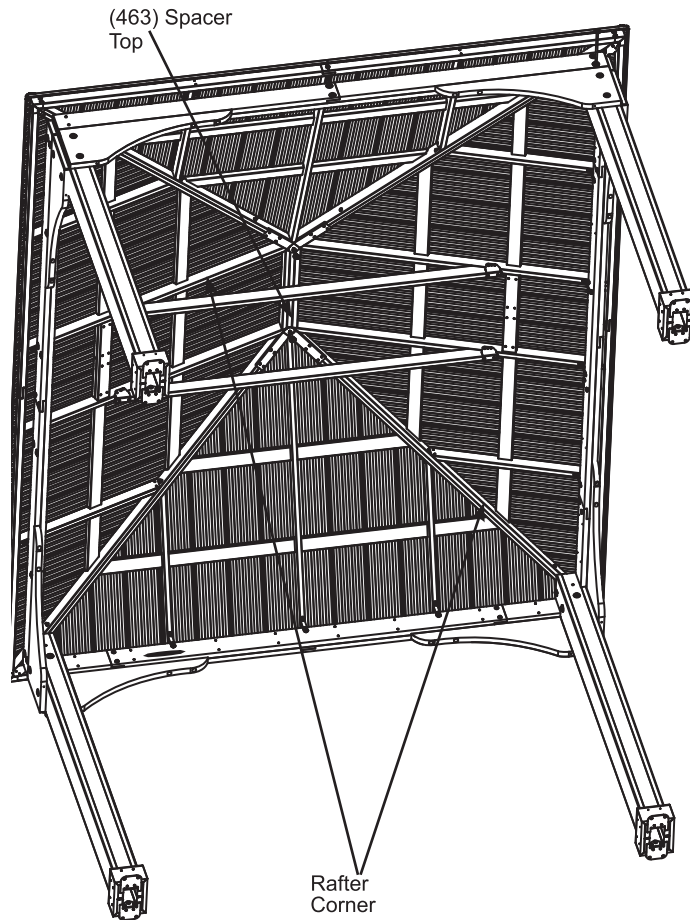

Note: DO NOT ATTACH ANY PRODUCT WHICH WEIGHS GREATER THAN 22 LBS (10 KG) TO THE EYE LAG

Note: We have provided two 50 mm hooks for optional use to hold in place any wires if required. These hooks are not designed to hold any heavy products such as lights, flower pots, etc.

F27.2

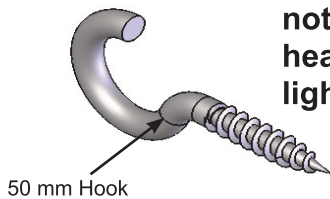

F27.3

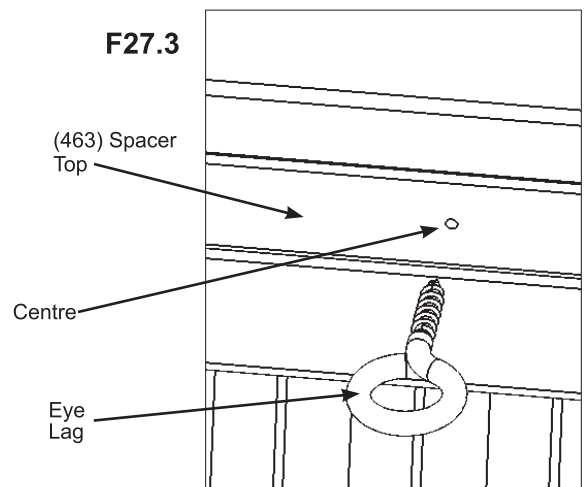

Hardware

- 2 x 50 mm Hooks
- 1 x Eye Lag

Step 27: Metal Hooks and Plaque Part 2

C: Attach Gazebo ID Plaque to a prominent location on your gazebo with two #8 x 1" Pan Screws. This provides warnings concerning safety and important contact information. A tracking number is provided to allow you to get critical information or order replacement parts for this specific model. (F27.4 and F27.5)

F27.4

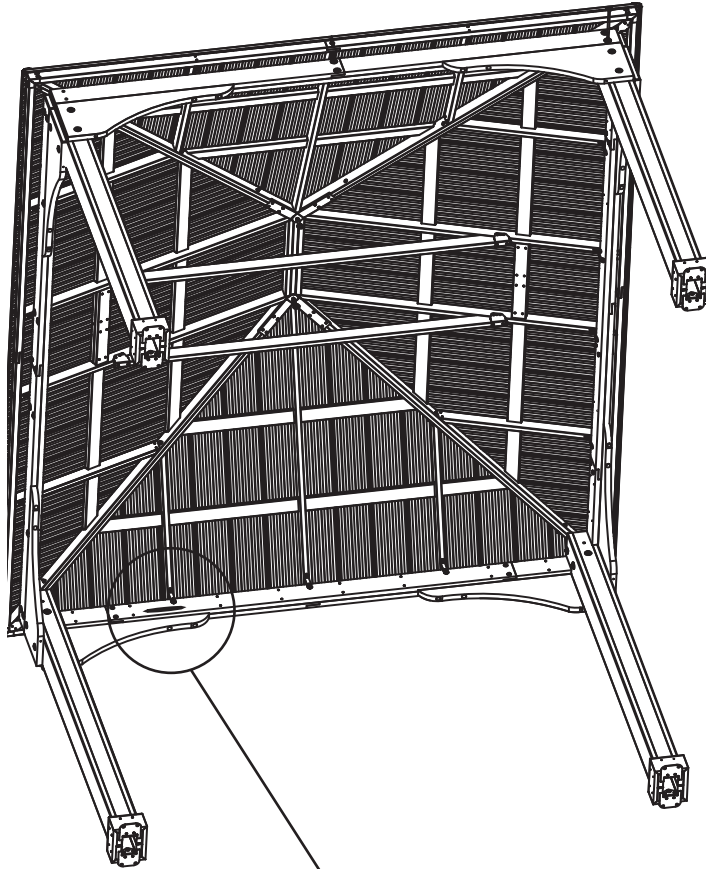

#8 x 1" Pan
Screw

F27.5

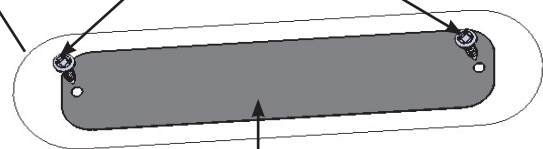

Gazebo
ID Plaque

Components

1 x Gazebo ID Plaque

Hardware

2 x #8 x 1" Pan Screw

YARDISTRY®

Yardistry® 375 Sligo Road West, P.O. Box 10, Mount Forest, ON Canada NOG 2L1

Distributed by:
Costco Wholesale Corporation
P.O. Box 34535
Seattle, WA 98124-1535
USA
1-800-774-2678
www.costco.com

Costco Wholesale Canada Ltd.*
415 W. Hunt Club Road
Ottawa, Ontario
K2E 1C5, Canada
1-800-463-3783
www.costco.ca

* faisant affaire au Québec sous
le nom les Entrepôts Costco

Importado por:
Importadora Primex S.A. de C.V.
Blvd. Magnocentro No. 4
San Fernando La Herradura
Huixquilucan, Estado de México
C.P. 52765
RFC: IPR-930907-S70
(55)-5246-5500
www.costco.com.mx

Costco Wholesale Australia Pty Ltd
17-21 Parramatta Road
Lidcombe NSW 2141
Australia
www.costco.com.au

Costco Wholesale UK Ltd /
Costco Online UK Ltd
Hartspring Lane
Watford, Herts
WD25 8JS
United Kingdom
01923 213113
www.costco.co.uk

Costco Wholesale Spain S.L.U.
Polígono Empresarial Los Gavilanes
C/ Agustín de Betancourt, 17
28906 Getafe (Madrid) España
NIF: B86509460
900 111 155
www.costco.es

Costco Wholesale Iceland ehf.
Kauptún 3-7, 210 Gardabaer
Iceland
www.costco.is

Costco France
1 avenue de Bréhat
91140 Villebon-sur-Yvette
France
01 80 45 01 10
www.costco.fr

Costco Wholesale Japan Ltd.
3-1-4 Ikegami-Shincho
Kawasaki-ku, Kawasaki-shi,
Kanagawa 210-0832 Japan
0570-200-800
www.costco.co.jp

Costco Wholesale Korea, Ltd.
40, Iljik-ro
Gwangmyeong-si
Gyeonggi-do, 14347, Korea
1899-9900
www.costco.co.kr

Costco Wholesale New Zealand Limited
2 Gunton Drive
Westgate
Auckland 0814
New Zealand

Costco (China) Investment Co., Ltd.
Room 1003, Block 2, 2388 Xiupu Road,
Pudong New Area, Shanghai
China 201315
+86-21-6257-7065

Costco Wholesale Sweden AB
Saluvägen 5
187 66 Täby
Sweden

AUSTRALIA: Our goods come with guarantees that cannot be excluded under the Australian Consumer Law. You are entitled to a replacement or refund for a major failure and for compensation for any other reasonably foreseeable loss or damage. You are also entitled to have the goods repaired or replaced if the goods fail to be of acceptable quality and the failure does not amount to a major failure.

AUSTRALIE : Nos articles sont offerts avec des garanties qui ne peuvent connaître d'exclusions au regard de la loi australienne sur la protection des consommateurs. Vous avez droit au remplacement ou au remboursement en cas de défaillance majeure de votre article ainsi qu'à une compensation en cas de perte ou de dommage prévisible. Vous avez aussi droit à la réparation ou au remplacement de l'article s'il n'est pas d'une qualité acceptable et que la défaillance n'est pas majeure.

AUSTRALIA: Nuestros productos cuentan con garantías que no se pueden excluir bajo las Leyes del Consumidor de Australia. Usted tiene derecho a un cambio o devolución en caso de un fallo importante ya una compensación por cualquier otra pérdida o daño razonablemente previsible. También tiene derecho a la reparación o reemplazo de los bienes, si éstos no cumplen con una calidad aceptable y el fallo no constituye un fallo importante.



Customer Registration Card - Tarjeta de Registro del Cliente - Carte d'inscription du client

First Name - Primer Nombre - Prénom	Initial - Inicial - Initiale	Last Name - Apellido - Nom de famille

Street - Calle - Rue	PO Box - Casilla postal - Boîte postale	Apt. No. - App.

City - Ciudad - Ville	State/Province - Estado/Provincia - État/Province

ZIP/Postal Code - Código Postal - ZIP/Code postal	Country - País - Pays

E-mail Address - Dirección de E-mail - Adresse courriel	Telephone Number - No. de Teléfono - N° de téléphone

Model Name - Nombre del Modelo - Nom du modèle	Model Number (from front cover) - Número de Modelo (de la portada) - N° du modèle (page de couverture)

Date of Purchase - Fecha de Compra - Date d'achat (mm/dd/yyyy) (mm/dd/aaaa) (mm/jj/aaaa)	Place of Purchase - Comprado a - Lieu d'achat

Comments - Comentarios - Commentaires:

Mail To - Enviar por Correo a - Envoyer par courrier à:

Yardistry
375 Sligo Road West, PO Box 10
Mount Forest, Ontario, Canada, N0G 2L0
Attention: Consumer Relations
Atención a: Servicio de Atención al Cliente
À l'attention de: Service à la clientèle

Online Registration - Registro online - Enregistrement en ligne:

www.yardistrystructures.com/warranty

Hours/ Heures/ Horas: 8:30 am - 5:00 pm EST
(excl. holidays/ hors jours fériés/ excepto los días festivos)

English and French Spoken / Anglais et français parlés / Inglés y francés hablado

Yardistry would like to say "Thank you" for your time and feedback.

Yardistry quiere "Agradecerle" por su tiempo y su opinión.

Yardistry aimerait vous remercier d'avoir pris le temps de répondre au sondage.