



UK ITM. / ART. 2127649  
ICELAND ITM. / ART. 529856

# 7-BURNER ISLAND GRILL

## Installation Instructions and Use & Care Guide

Missing Parts / Questions / Issues

For assistance with parts, assembly, installation, etc. Please call: **0800-051-8916 (UK)** or **800-7601 (Iceland)**  
Office Hours 7:30a.m.- 5 p.m. Monday-Thursday, 7:30a.m.- 2p.m. Friday, GMT+2

Costco Member Service Number: 01923 213113  
Operating hours 8 a.m.-5 p.m. Monday-Friday.



**UK**  
**CA** 8504DO-0001  
8504-23

**CE** 2531DO-0001  
2531-23

**IMPORTANT, RETAIN FOR FUTURE REFERENCE: READ CAREFULLY.**

**FOR OUTDOOR USE ONLY. NOT FOR COMMERCIAL USE.**

---

# TABLE OF CONTENTS

<b>OUTDOOR GRILL SAFETY</b> .....	3	Cooking Methods .....	12
<b>INSTALLATION REQUIREMENTS</b> .....	5	<b>OUTDOOR GRILL CARE</b> .....	13
Location Requirements.....	5	Replacing the Igniter Battery .....	13
Product Dimensions.....	6	General Cleaning .....	13
European Gas Pressures and Specifications.....	7	<b>ADJUSTMENT OF GRILL DOORS</b> .....	15
Gas Connection Requirements .....	8	<b>TROUBLESHOOTING</b> .....	16
Gas Connection .....	8	<b>ASSISTANCE</b> .....	16
Checking and Adjusting Burners.....	9	Accessories.....	16
<b>OUTDOOR GRILL USE</b> .....	10	<b>WARRANTY</b> .....	17
Using Your Outdoor Grill .....	11	<b>PACKAGE PARTS LIST</b> .....	19
Using Your Top Sear Burner.....	11	<b>ASSEMBLY INSTRUCTIONS</b> .....	21
Using Your Side Burner.....	11	<b>REPLACEMENT PARTS</b> .....	31
<b>TIPS FOR OUTDOOR GRILLING</b> .....	12		

---

# OUTDOOR GRILL SAFETY

## Your safety and the safety of others are very important.

We have provided many important safety messages in this manual and on your appliance. Always read and obey all safety messages.



This is the safety alert symbol.

This symbol alerts you to potential hazards that can kill or hurt you and others.

All safety messages will follow the safety alert symbol and either the word "DANGER" or "WARNING."

These words mean:

 **DANGER**

You can be killed or seriously injured if you don't immediately follow instructions.

 **WARNING**

You can be killed or seriously injured if you don't follow instructions.

All safety messages will tell you what the potential hazard is, tell you how to reduce the chance of injury, and tell you what can happen if the instructions are not followed.

## DANGER

If you smell gas:

1. Shut off gas to the appliance.
2. Extinguish any open flame.
3. Open lid.
4. If odor continues, keep away from the appliance and immediately call your gas supplier or your fire department.

## WARNING

1. Do not store or use gasoline or other flammable liquids or vapors in the vicinity of this or any other appliance.
2. An LP cylinder not connected for use shall not be stored in the vicinity of this or any other appliance.

# IMPORTANT SAFETY INSTRUCTIONS

**WARNING:** To reduce the risk of fire, electrical shock, injury to persons, or damage when using the outdoor cooking gas appliance, follow basic precautions, including the following:

- Do not install portable or built-in outdoor cooking gas appliances in or on a recreational vehicle, portable trailer, boat or in any other moving installation.
- Always maintain minimum clearances from combustible construction, see "Location Requirements" section.
- This appliance must be kept away from flammable materials during use.
- The outdoor cooking gas appliance shall not be located under overhead unprotected combustible construction.
- This outdoor cooking gas appliance shall be used only outdoors and shall not be used in a building, garage, or any other enclosed area.
- Keep any electrical supply cord and fuel supply hose away from any heated surfaces.
- Keep outdoor cooking gas appliance area clear and free from combustible material, gasoline and other flammable vapors and liquids.
- It is forbidden to place gas cylinder on the bottom panel of the appliance.
- Do not obstruct the flow of combustion and ventilation air. Keep the ventilation openings of the storage enclosure free and clear from debris.
- Inspect the gas cylinder supply hose before each use of the outdoor cooking gas appliance. If the hose shows excessive abrasion or wear, or is cut, it **MUST** be replaced before using the outdoor cooking gas appliance. Contact your dealer and use only replacement hoses specified for use with the outdoor cooking gas appliance.
- Visually check the burner flames. They should be blue. Slight yellow tipping is normal for LPG gas. The flames should be approximately 2.54 cm (1") high.



- Check and clean burner/venturi tube for insects and insect nest. A clogged tube can lead to fire under the outdoor cooking gas appliance.
- This appliance will be hot during and after use. Use insulated oven mitts or gloves for protection from hot surfaces or splatter from cooking liquids.

- Only the pressure regulator and hose assembly supplied with the grill should be used. Any replacement pressure regulator and hose assembly should comply with EN 16129:2013 and the national regulation. The flexible hose used, with a length not exceeding 1.50 meters, should comply with EN 16436-1:2014. This grill is configured for liquefied petroleum gas. Do not use a natural gas supply.
- Make sure that the hose is not subjected to twisting.
- Always check connections for leaks each time you connect and disconnect the LPG gas supply cylinder. See "Installation Instructions" section.
- When the outdoor cooking gas appliance is not in use, the gas must be turned off at the supply cylinder.
- Storage of an outdoor cooking gas appliance indoors is permissible only if the cylinder is disconnected and removed from the outdoor cooking gas appliance.
- Cylinders must be stored outdoors and out of the reach of children and must not be stored in a building, garage, or any other enclosed area.
- The pressure regulator and hose assembly supplied with the outdoor cooking gas appliance must be used. A replacement pressure regulator and hose assembly specific to your model is available from your outdoor cooking gas appliance dealer.
- Gas cylinder must include a collar to protect the cylinder valve.
- Use Outdoors only. Read the instruction before using the appliance.
- **WARNING:** Accessible parts may be very hot. Keep young children away.
- Do not move the appliance during use.
- Turn off the gas supply at the gas cylinder after use.
- It is recommended to change the flexible hose when the conditions require it.
- Parts sealed by the manufacture shall not be altered by the user.
- Do not modify the appliance.

If the following information is not followed exactly, a fire causing death or serious injury may occur.

- Do not store a spare LPG gas cylinder under or near this outdoor cooking gas appliance.
- Never fill the cylinder beyond 80 percent full.
- When changing the gas cylinder, make sure you are away from any source of ignition.

## SAVE THESE INSTRUCTIONS

# INSTALLATION REQUIREMENTS

## Location Requirements

### **⚠ WARNING**



#### **Explosion Hazard**

**Do not store fuel tank in a garage or indoors.**

**Do not store grill with fuel tank in a garage or indoors.**

**Failure to follow these instructions can result in death, explosion, or fire.**

Select a location that provides minimum exposure to wind and traffic paths. The location should be away from strong draft areas.

Do not obstruct flow of combustion and ventilation air.

Clearance to combustible construction for grill:

- A minimum of 91 cm / 36 in must be maintained between the front of the grill hood, sides, and back of the grill and any combustible construction.
- A 91 cm / 36 in minimum clearance must also be maintained below the cooking surface, and the grill shall not be used under overhead combustible construction.

#### **Rotisserie (accessory is not included)\***

If you equip your grill with a rotisserie, a 15.24 cm / 6 in minimum clearance is needed for the rotisserie motor.

A grounded, 3-prong outlet located to the left of the grill is required.

\*See "Assistance" section to order.

### **⚠ WARNING**



#### **Fire Hazard**

**Do not use grill near combustible materials.**

**Do not store combustible materials near grill.**

**Doing so can result in death or fire.**

# INSTALLATION REQUIREMENTS

## Production Dimensions

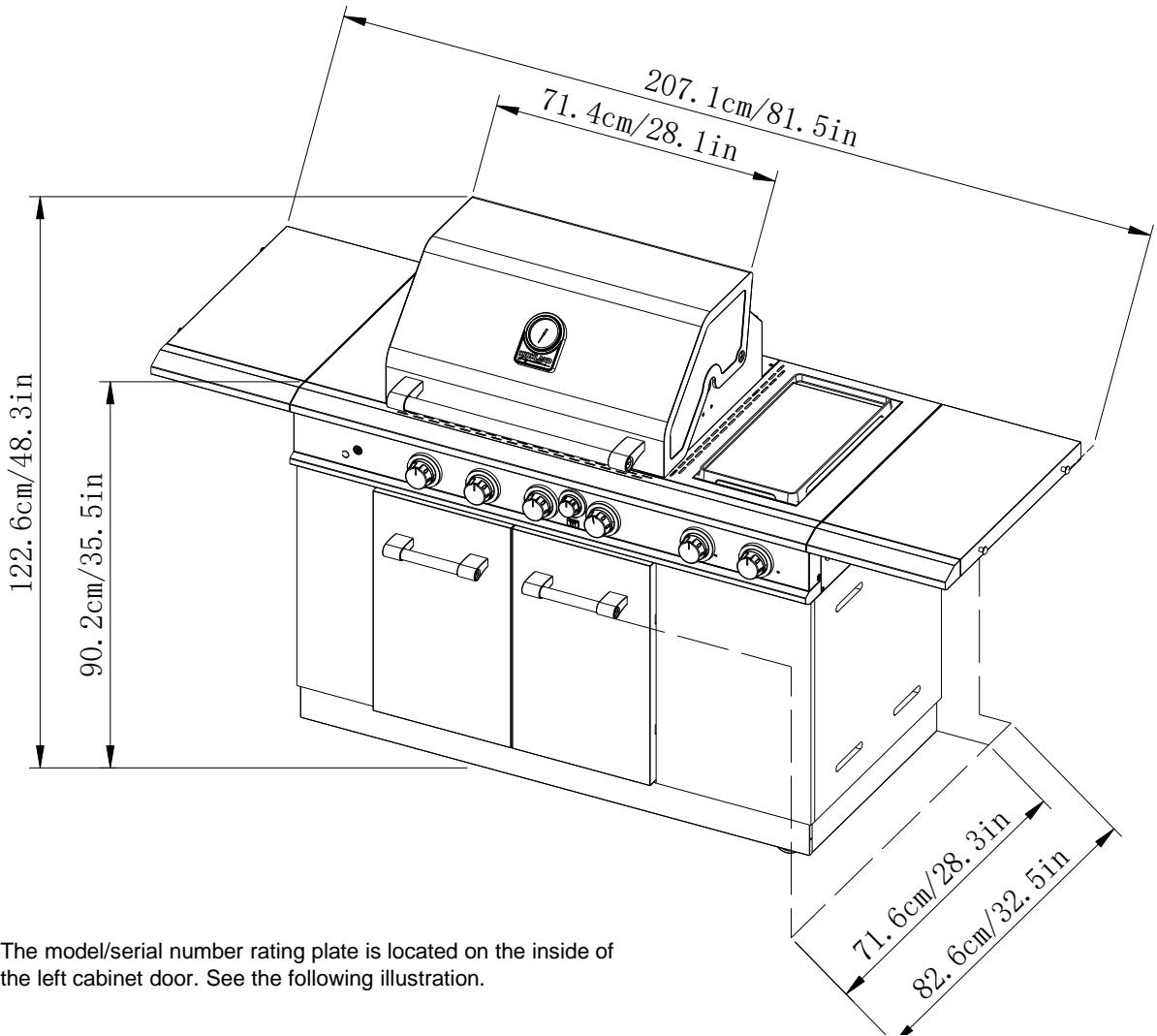

The model/serial number rating plate is located on the inside of the left cabinet door. See the following illustration.

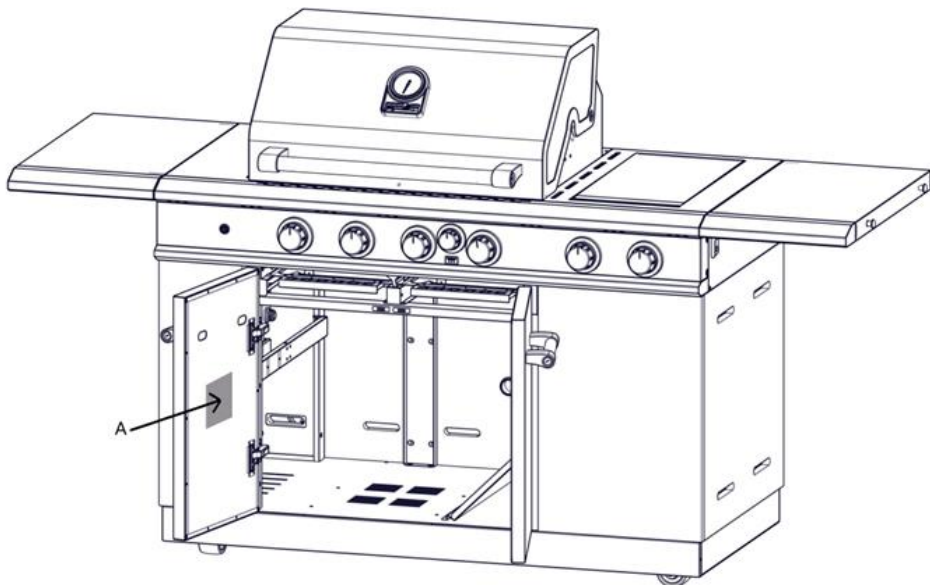

A. Model/serial number plate

## European Gas Pressures and Specifications

Nexgrill Industries, Inc.  
14050 Laurelwood PI Chino, CA 91710 USA

Model	860-0030				
Appliance category	I <sub>3+(28-30/37)</sub>		I <sub>3B/P(30)</sub>	I <sub>3B/P(37)</sub>	I <sub>3B/P(50)</sub>
Type of gas	Butane	Propane	Butane, Propane or their mixture		
Gas pressure (mbar)	28-30	37	30	37	50
Main Burner Injector size (Ø mm)	0.90		0.90	0.83	0.80
Top Sear Burner Injector size (Ø mm)	0.90		0.90	0.83	0.80
Side Burner Injector size (Ø mm)	0.80		0.80	0.76	0.70
Nominal heat input (Hs) (kW)	Total: 21.0				
Gas consumption (g/h) (total)	Butane - Total: 1528				
	Propane - Total: 1501				

**NOTE:**

Use 30 mbar regulator and its corresponding injector size for butane/propane under the category I<sub>3B/P(30)</sub>.  
 Use 30 mbar regulator and its corresponding injector size for butane under the category I<sub>3+(28-30/37)</sub>.  
 Use 37 mbar regulator and its corresponding injector size for propane under the category I<sub>3+(28-30/37)</sub>.  
 Use 50 mbar regulator and its corresponding injector size for butane/propane under the category I<sub>3B/P(50)</sub>.

Marking on the injector indicate the injector size. For example, "0.90" means the injector size is 0.90 mm.

Country	Gas Type	Pressure
BE, FR, IT, LU, IE, GB, GR, PT, ES, CY, CZ, LT, SK, CH, SI, LV	I <sub>3+</sub>	28-30/37 mbar
LU, NL, DK, FI, SE, CY, CZ, EE, LT, MT, SK, SI, BG, IS, NO, TR, HR, RO, IT, HU, LV	I <sub>3B/P</sub>	30 mbar
PL	I <sub>3P</sub>	37 mbar
AT, DE, CH, SK	I <sub>3B/P</sub>	50 mbar

\*Country codes are in accordance with EN ISO 3166-1:2006.

# Gas Connection Requirements

## Liquefied Petroleum Gas Fuel Tank

Only use cylinders with a minimum capacity of 5 kg and a maximum capacity of 15 kg. A tank of approximately 318 mm (12.5 in) in diameter by 580 mm (22.8 in) in height shall be the maximum size LPG cylinder which can be used. A gas pressure regulator/hose assembly is supplied.

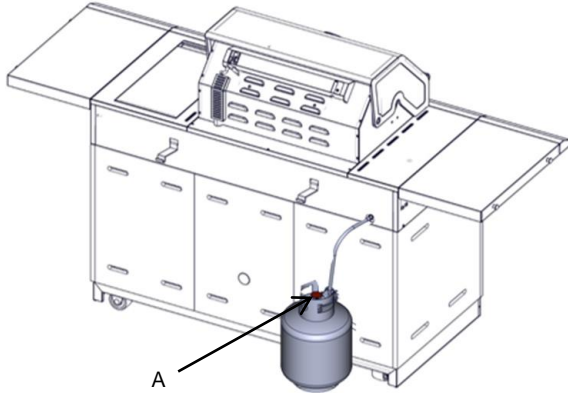
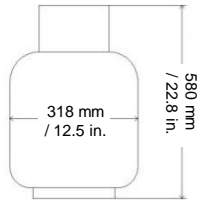

A. Gas pressure regulator/hose assembly

**NOTE:** Always keep the LPG cylinder at 90° (upright) orientation to provide vapor withdrawal.

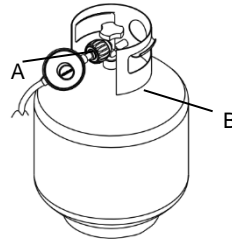

A. Gas pressure regulator/hose assembly  
B. LPG fuel tank

- Some regulators push ON to connect and pull OFF to disconnect, whereas others have a nut that either have a left-hand or a right-hand thread that connects to the cylinder valve. Identify your regulator type and follow the connection instructions specific to that regulator.

### Connect by Turning Clockwise

Screw regulator onto cylinder by turning the connecting nut clockwise.

### Connect by Turning Anti-Clockwise

Screw regulator onto cylinder by turning the connecting nut anti-clockwise.

### Connect by Turning Lever/Snapping into Position

Turn regulator lever clockwise to the OFF position. Push regulator down on cylinder valve until you hear the audible 'click'. Check that the regulator is fully locked and in place by gently pulling upwards. If regulator disengages, repeat procedure.

### Connect by Sliding Collar

Make sure regulator lever is in the off position. Slide the retaining ring of the regulator up. Push the regulator down onto the cylinder valve and maintain downward pressure on the regulator. Slide retaining ring down to lock regulator onto cylinder valve. Check that the regulator is secured. If the regulator disengages, repeat procedure.

**Note:** If your grill is not equipped with a hose and regulator assembly, please refer to the "European Gas Pressures and Specifications" table to clarify the regulator gas pressure and orifice size required.

## Gas Connection

### LPG Fuel Tank

**IMPORTANT:** An LPG fuel tank must be purchased separately.

**IMPORTANT:** The gas pressure regulator/hose assembly supplied with the grill must be used. Replacement gas pressure regulator/hose assembly specific to your model is available from your outdoor grill dealer.

**IMPORTANT:** It is forbidden to place gas cylinder on the bottom panel of the appliance.

### To Connect the LPG Fuel Tank:

- Check LPG gas fuel tank is in the "OFF" position. If not, turn the valve clockwise until it stops.
- Check that the burner control knobs are in the "OFF" position.
- Remove any debris and inspect the valve connections, port, and gas pressure regulator/hose assembly for damage.

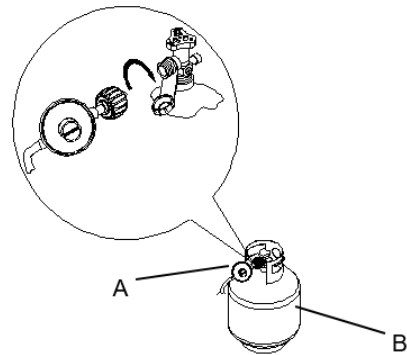

A. Gas pressure regulator/hose assembly  
B. LPG fuel tank

Make sure that the cylinder valve connection device properly mates with the connection device attached to the inlet of the pressure regulator.



- Turn the gas supply on at source by following the instructions specific to that regulator.
  - Screw-on regulator**  
Turn the valve handwheel, located at the cylinder, anti-clockwise.
  - Clip-on regulator**  
Move the regulator lever to the ON position.
- Before lighting the grill, test all connections by brushing on an approved noncorrosive leak-detection solution. Bubbles will show a leak.
- If a leak is found, turn the tank valve off and do not use the grill. Contact a qualified gas technician to make repairs.
- Go to "Check and Adjust the Burners" section.

#### To Disconnect the LPG Gas Fuel Tank:

- Check that the burner control knobs are in the "OFF" position and the grill is cool.
- Check that the LPG gas fuel tank is in the "OFF" position. If not, turn the valve clockwise until it stops.
- Identify your regulator type. Turn the gas supply off at source and disconnect regulator from cylinder by following the instructions specific to that regulator.
  - Disconnect by Turning Anti-Clockwise**  
Turn the valve handwheel, located at the cylinder, clockwise. Unscrew regulator from cylinder by turning the connecting nut anti-clockwise.
  - Disconnect by Turning Clockwise**  
Turn the valve handwheel, located at the cylinder, clockwise. Unscrew regulator from cylinder by turning the connecting nut clockwise.
  - Disconnect by Turning Lever/Snapping into Position**  
Move the regulator lever to the OFF position. Push in on regulator lever until it releases from cylinder.
  - Disconnect by Sliding Collar**  
Move the regulator lever to the OFF position. Pull up on the retaining ring to disengage regulator from cylinder valve. Lift regulator away from the cylinder valve.
- Place dust cap on cylinder valve outlet whenever the cylinder is not in use. Only install the type of dust cap on the valve outlet that is provided with the cylinder valve. Other types of caps or plugs may result in leakage of liquified petroleum gas.

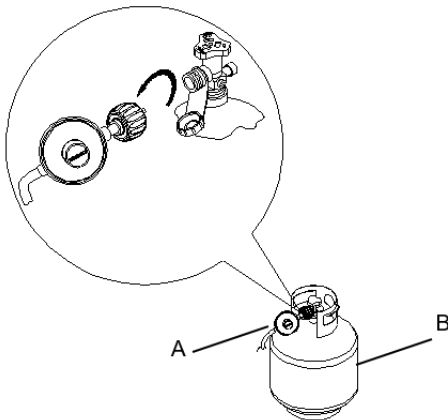

- A. Gas pressure regulator/hose assembly
- B. LPG gas fuel tank

## Check and Adjust the Burners

The burners are tested and factory-set for most efficient operation. However, variations in gas supply and other conditions may make minor adjustments to air shutter or low flame setting necessary. It is recommended that a qualified person make burner adjustments. Checking and adjusting the grill burner flames requires removing the grates and flame tamers.

#### Burner Flame Characteristics

The flames of the grill burners and side burners (on some models) should be blue and stable with no excessive noise or lifting (LP gas flames will have a slightly yellow tip). A yellow flame indicates not enough air. If flame is noisy or lifts away from the burner, there is too much air. Some yellow tips on flames when the burner is set to HIGH setting are acceptable as long as no carbon or soot deposits appear. The flames should be approximately 2.54 cm / 1 in high.



Check that burners are not blocked by dirt, debris, insect nests, etc., and clean as necessary.

# OUTDOOR GRILL USE

This manual covers several different models. The grill you have purchased may have some or all of the features listed. The locations and appearances of the features shown here may not match those of your model.

## Control Panel

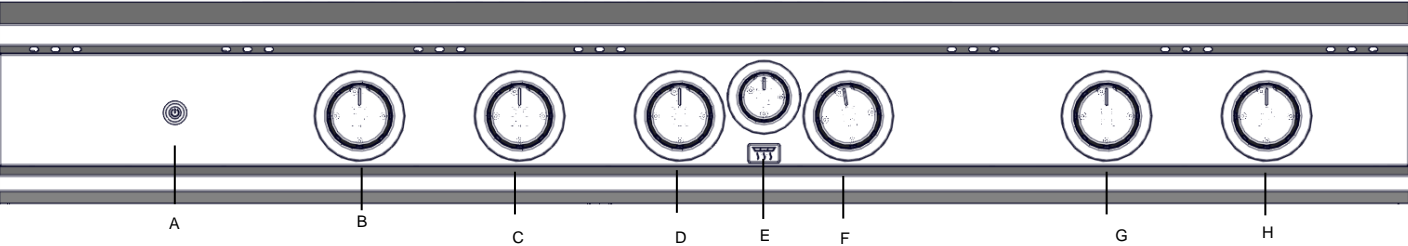

- |  |                                  |   |
|--|----------------------------------|---|
| A. Knob Light Switch Bottom              | B. Left main burner control knob | C. Left center main burner control knob |
| D. Right center main burner control knob | E. Top sear burner control knob  | F. Right main burner control knob       |
| G. Front Side burner control knob        | H. Back Side burner control knob |   |

## Using Your Outdoor Grill

### **⚠ WARNING**



#### Explosion Hazard

Do not store fuel tank in a garage or indoors.  
Do not store grill with fuel tank in a garage or indoors.  
Failure to follow these instructions can result in death, explosion, or fire.

### **⚠ WARNING**



#### Fire Hazard

Do not use grill near combustible materials.  
Do not store combustible materials near grill.  
Doing so can result in death or fire.

### **⚠ WARNING**

#### Food Poisoning Hazard

Do not let food sit for more than one hour before or after cooking.  
Doing so can result in food poisoning or sickness.

## Inspect the Propane Tank Supply Hose

Inspect the gas pressure regulator/hose assembly before each use.

1. Open left -hand cabinet door.
2. Inspect the gas pressure regulator/hose assembly for cuts, abrasions, or excessive wear.
3. If necessary, replace the gas pressure regulator/hose assembly before using the grill.  
Contact the dealer and use only replacement hoses specified for use with the grill.

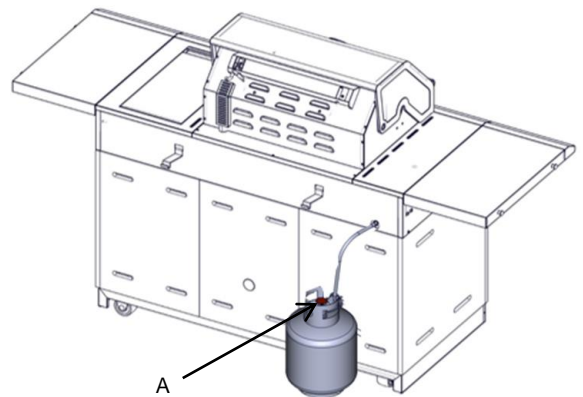

A. Gas pressure regulator / Hose assembly

---

### Prepare the Grill for Lighting

---

1. Open the hood completely. Do not light burners with the hood closed.
2. Make sure control knobs are turned to "O".
3. The grease trays must be in place and push all the way to back.

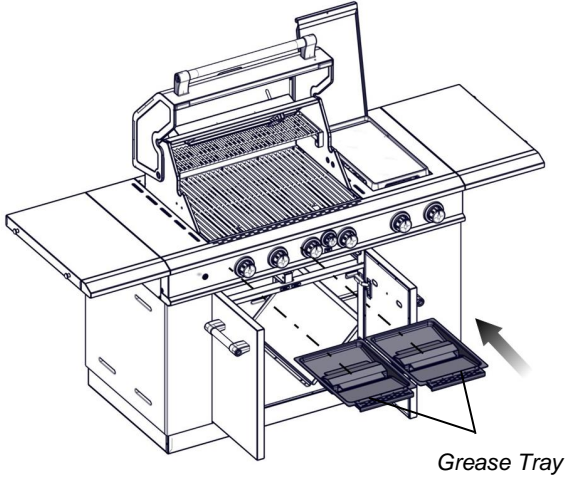

---

### Turn the Gas Supply On

---

1. For outdoor grills using LPG Fuel Tank:  
Slowly open the tank valve.  
NOTE: If flow limiting device activates, your grill may not light. If your grill does light, the flames will be low and will not heat properly. Turn tank valve and all control knobs off and wait 30 seconds. After shutting off the tank, very slowly open tank valve and wait 5 seconds before lighting.

---

### Lighting the Grill Burners

---

**IMPORTANT:** If burner does not light immediately, turn the burner knob to "O" and wait 5 minutes before relighting.

1. Open the hood completely. Do not light burners with the hood closed.
2. Do not lean over the grill.
3. Select the burner you want to light. Push in and turn the grill burner control knob to "🔥", while continuing to hold it in.

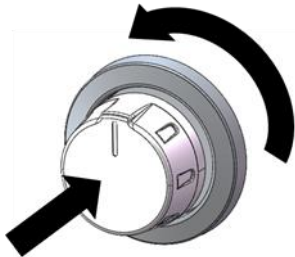

4. You will hear the "snapping" sound of the spark. When burner is lit, release the knob. Turn knob to desired setting.
5. Repeat for each of the other burners as needed.

---

### Lighting the Top Sear Burner

---

**NOTE:** Do not use the main burners when the top sear burner is in use.

1. Open the main burner cover. Do not light burners with the cover on.
2. Do not lean over the grill.
3. Push in and turn the grill control knob to "●", while continuing to hold it in.

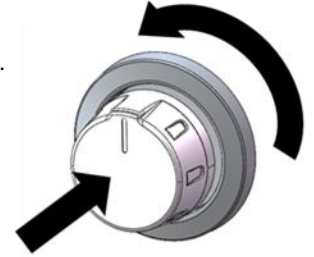

**IMPORTANT:** If burner does not light immediately, turn the burner knob to "O" and wait 5 minutes before relighting.

---

### Using the Top Sear Burner

---

Grilling with Top Sear Burner produces a high heat which quickly chars foods. Searing creates and locks in flavors on the outside and creates a beautifully-browned surface and texture. The result is a crisp, flavorful outside with a tender, juicy inside.

- Lift the lid on the top sear burner.
- Check that the sear grill grate is in place before using the side burner.
- Turn on the top sear burner and preheat for 5 minutes.
- Ensure that foods are fully thawed, and that excess fat is trimmed off prior to searing.
- Place food on sear grate. Sear food for 1 to 2 minutes on each side, then move the food to the main grill cooking surface to finish grilling to desired doneness.
- Turn off the top sear burner and allow burner to cool down.

---

### Lighting the Side Burner

---

1. Open the side burner cover. Do not light burners with the cover on.
2. Do not lean over the grill.
3. Push in and turn the grill control knob to "🔥", while continuing to hold it in.

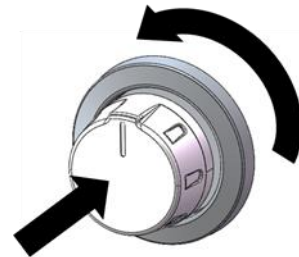

**IMPORTANT:** If burner does not light immediately, turn the burner knob to "O" and wait 5 minutes before relighting.

---

# TIPS FOR OUTDOOR GRILLING

---

## **⚠ WARNING**

### **Food Poisoning Hazard**

**Do not let food sit for more than one hour before or after cooking.**

**Doing so can result in food poisoning or sickness.**

---

### **Before Grilling**

---

- Thaw food items before grilling.
- Preheat grill on high (use all grill burners) for 10 minutes. The hood must be closed during preheating. Preheating provides the high heat needed to brown and seal the juices.
- Shorten the preheat time when grilling high-fat cuts of meat or poultry, such as chicken thighs. This will help reduce flare-ups.
- Lightly oil the grill grates, or the food when cooking low-fat cuts of meat, fish, or poultry, such as lean hamburger patties, shrimp or skinless chicken breasts.
- Using too much oil can cause gray ash to deposit on food. Trim excess fat from meats prior to cooking to reduce flare-ups.
- Make vertical cuts at 5 cm / 2 in intervals around the fat edge of meat to avoid curling.
- Add seasoning or salt only after the cooking is finished.

---

### **During Grilling**

---

- Turn foods only once. Juices are lost when meat is turned several times.
- Turn meat just when juices begin to appear on the surface.
- Avoid puncturing or cutting the meats to test doneness. This allows juices to escape.
- It may be necessary to lower the heat setting for foods that cook a long time or are marinated or basted in a sugary sauce.
- If using a high flame, add barbecue sauce only during the last 10 minutes of cooking to avoid burning the sauce.
- The degree of doneness is influenced by the type of meat, cut of meat (size, shape, and thickness), heat setting selected, and length of time on the grill.
- Cooking time will be longer with an open grill cover.

---

## **Cooking Methods**

---

---

### **Direct Heat**

---

Cooking by direct heat means the food is placed on grill grates directly above or below lighted burners. Hood position can be up or down. If hood is in the up position, total cooking times may be longer.

Direct heat sears the food. Searing is a process that seals natural juices in food by cooking with intense heat for a short period of time. While juices stay inside, the outside is browned with a flavorful grilled coating.

---

### **Indirect Heat**

---

For best results, do not select the indirect heat cooking method when it is windy.

Cooking by indirect heat means the food is placed on the grill grate above an unheated burner, allowing heat from lighted burner(s) on either side to cook the food.

If possible, turn on 2 burners. Cook with the hood down. This will shorten the cooking time.

---

# OUTDOOR GRILL CARE

---

## Replacing the Igniter Battery

If igniters stop sparking, the battery should be replaced.

1. The igniter button cap is located inside the left door.
2. Unscrew igniter button cap counterclockwise to remove.

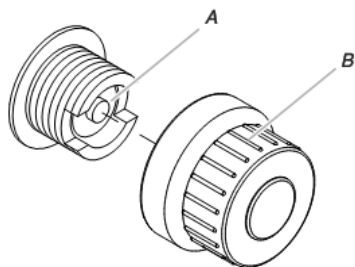

A. "AA" size battery  
B. Igniter cap

3. Remove battery from the battery compartment.
4. Replace with a new alkaline "AA" size battery. Install battery with negative end in first.
5. Screw igniter button cap clockwise into place.

---

## General Cleaning

**IMPORTANT:** Before cleaning, make sure all controls are off and the grill is cool. Always follow label instructions on cleaning products.

For routine cleaning, wash with soap and water using a soft cloth or sponge. Rinse with clean water and dry at once with a soft, lint-free cloth to avoid spots and streaks.

Do not use steel wool to clean the grill, as it will scratch the surface.

To avoid weather damage to finish, use grill cover.

---

### STAINLESS STEEL

**IMPORTANT:** To avoid damage to stainless steel surfaces, do not use soap-filled scouring pads, abrasive cleaners, cooktop polishing creme, steel wool, gritty wash cloths, or paper towels. Cleaner should not contain chlorine. Damage may occur.

Food spills should be cleaned as soon as entire grill is cool. Spills may cause permanent discoloration.

#### Cleaning Method:

- Rub in direction of grain to avoid scratching or damaging the surface.
- Stainless steel cleaner.
- Liquid detergent or all-purpose cleaner.
- Rinse with clean water and dry with soft, lint-free cloth.
- Vinegar to remove hard water spots.
- Glass cleaner to remove fingerprints.

---

### STONE PANEL

#### Cleaning Method:

- Do dust surface frequently.
- Clean panel with water and mild detergent.
- Do not use any cleaning chemical to clean the stone panel.
- Do not use vinegar, mix bleach or bathroom cleaner to wash the stone panel.

---

### GRILL GRATES

**IMPORTANT:** Immediately after you are finished cooking, turn all burners to HIGH for 10-15 minutes with the hood closed to burn off food residue. Turn off all burners, raise the hood and let the grates cool. When completely cool, grill racks can be removed for thorough cleaning. Clean them with a mild detergent and warm water. For baked-on food residue, prepare a solution of 240 mL / 1 cup ammonia to 3.75 L / 1 gal. water. Soak grates for 20 minutes, then rinse with water and dry completely.

---

### WARMING AND SEARING SHELF

#### Cleaning Method:

- Liquid detergent or an all-purpose cleaner.
- Rinse with clean water and dry with soft, lint-free cloth.
- For tough spots or baked-on grease, use a commercial degreaser.

**IMPORTANT:** Make sure gas supply is off and all control knobs are in the "O" position.

---

### EXTERIOR

The quality of this material resists most stains and pitting, providing that the surface is kept clean, polished, and covered.

#### Cleaning Method:

- Apply stainless steel polish to all non-cooking areas before first use. Reapply after each cleaning to avoid permanent damage to surface.
- Cleaning should always be followed by rinsing with clean warm water. Wipe the surface completely dry with a soft cloth.
- For tough spots or baked-on grease, use a commercial degreaser stainless steel.

---

### INTERIOR

Discoloration of stainless steel on these parts is to be expected, due to intense heat from the burners. Always rub in the direction of the grain. Cleaning should always be followed by rinsing with clean, warm water.

#### Cleaning Method:

- Liquid detergent or all-purpose cleaner.
- Rinse with clean water and dry completely with a soft, lint-free cloth.
- A heavy-duty scrub sponge can be used with mild cleaning products.
- For small, difficult-to-clean areas, use a commercial degreaser designed for stainless steel.

---

## BURNERS

---

### Cleaning Method:

- Clean the exterior of the burner with a wire brush.
- Clear any clogged burner ports with a straightened paper clip.
- Do not use a toothpick as it may break off and clog the port.
- Check and clean burner/venturi tubes.

1. Remove grill grates and flame tamers.
2. Remove the screw and cotter pin that hold the burner in place. Remove gas burner from the grill.

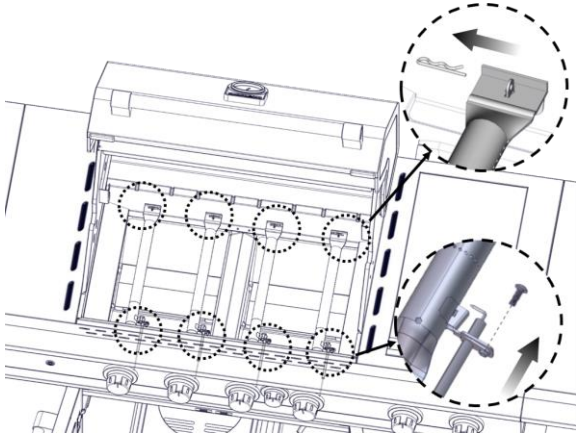

3. Use a flashlight to inspect into the burner through the burner inlet to ensure there is no blockage. If any obstruction is seen, use a metal coat hanger that has been straightened to clear them.
4. After inspecting the inside of burner for blockage, reassemble burner by sliding the middle tube of the gas burner over the gas orifice.

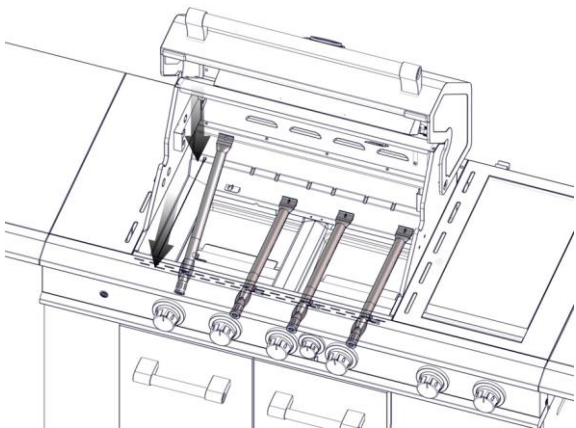

5. Reattach gas burner using screw and cotter pin.

---

## TOP SEAR BURNER

---

### Cleaning Method:

1. Light the top sear burner. See the “Using Your Top Sear Burner” section.
2. Close the grill hood.
3. Leave the burner on high for approximately 30 minutes.
4. Turn knob to OFF and let cool completely.
5. Brush off ash particles from the top sear burner.

---

## SIDE BURNER

---

### Cleaning Method:

- Clean the exterior of the side burner with a wire brush.

---

## CAST IRON COOKING GRID

---

### Cleaning Method:

1. Allow the burner cool down completely.
2. Clean the cooking grid with a wire brush.

---

## GREASE MANAGEMENT SYSTEM

---

**IMPORTANT:** The grease tray should only be removed when grill is completely cool. The grease tray collects grease and food particles that fall through the grill. Clean often to avoid grease buildup.

### Cleaning Method:

- Remove the grease tray from the grill and remove the heat tent from the tray.
- Wipe excess grease with mild detergent and warm water by using paper towels.
- Rinse and dry thoroughly.
- Replace heat tent to grease tray and insert the grease tray to the grill.

---

## KNOBS AND FLANGE AREA AROUND KNOBS

---

**IMPORTANT:** To avoid damage to knobs or flange area around knobs, do not use steel wool, abrasive cleaners, or oven cleaner. Do not soak knobs.

### Cleaning Method:

- Mild detergent, a soft cloth and warm water.
- Rinse and dry.

---

## CONTROL PANEL GRAPHICS

---

**IMPORTANT:** To avoid damage to control panel graphics, do not use steel wool, abrasive cleaners or oven cleaner. Do not spray cleaner directly onto panel.

### Cleaning Method:

- Clean around the burner labels gently; scrubbing may remove printing.
- Mild detergent, soft cloth and warm water.
- Rinse and dry.

# ADJUSTMENT OF GRILL DOORS

Your grill is equipped with adjustable door hinges which may need adjustment if doors become misaligned. The hinges are made of two pieces which can easily be detached if door removal is ever necessary for maintenance.

## Removal of Grill Doors

In the case where removal of your doors is necessary, detach the hinge from the mounting plate by pinching the lever on the back of the hinge piece.

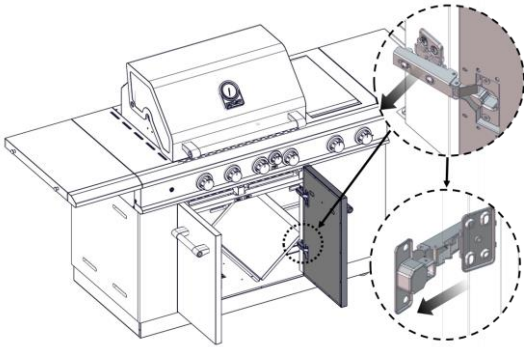

After detaching the bottom hinge, repeat for the top hinge. It will be necessary to support the door during this process.

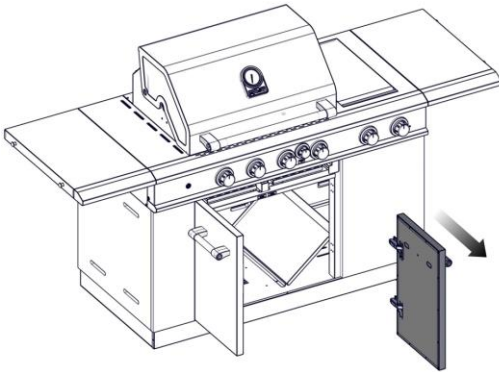

## Reinstallation of Grill Doors

To reinstall your grill doors, move the door into position while aligning the hinge mechanism. First, hook the front of the hinge piece then push the back until you hear a click.

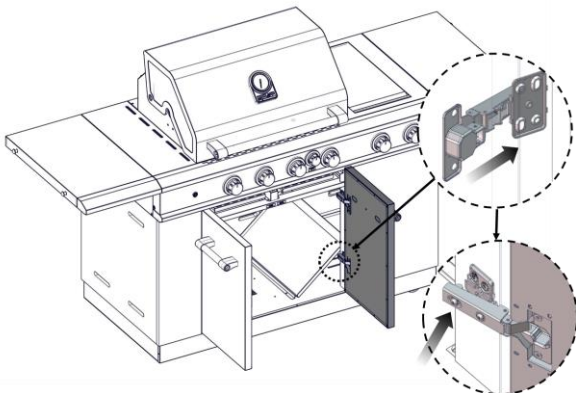

## Adjustment of Grill Doors

In the case that your grill doors need minor adjustments, the two screws on the main hinge piece can be adjusted as shown below.

### Depth Adjustment

To adjust the depth of the door, loosen the rear set screw, adjust the hinge front to back as needed, then retighten the set screw.

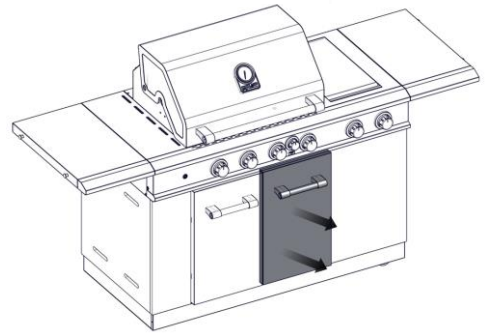
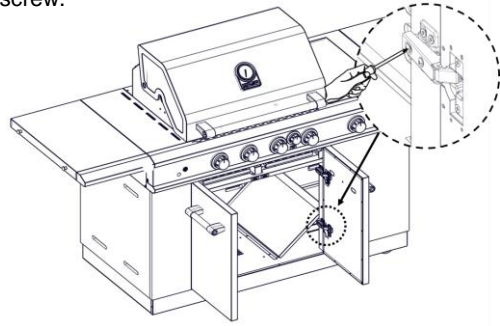

### Lateral Adjustment

Turning the front set screw clockwise will close the gap between the doors. Turning the front set screw counter-clockwise will create a gap between the doors.

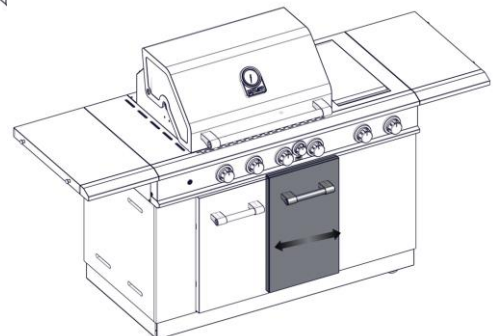
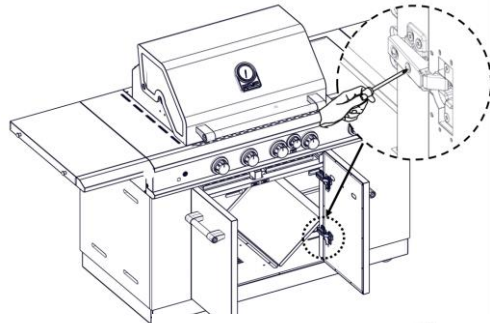

---

# TROUBLESHOOTING

---

## Grill will not light

---

- **Is the LPG fuel tank valve turned off?**  
Turn the LPG fuel tank on.
- **Is the grill properly connected to the gas supply?**  
Contact a trained repair specialist or see Installation Instructions.
- **Is there gas in the LPG gas fuel tank?**  
Check the gas level.
- **Is the igniter working?**  
Check that the igniter battery is properly installed or check to see if the battery needs to be replaced. See the "Replacing the Igniter Battery" section.  
Check to see if the grill will match-light. See "Manually Lighting the Grill and side burner" in the "Outdoor Grill Use" section.  
Check for loose wire connections to the igniter or electrodes.  
Check to see if debris is blocking the electrodes. If a spark occurs anywhere but the igniter tip, replace the igniter.

---

## Burner flame will not stay lit

---

- **Is the gas supply fully turned on?**  
Check that the LPG fuel tank valve is fully open.
- **Is the gas supply in the LPG fuel gas tank low?**  
Check the gas level.
- **Is the burner properly installed and in good condition?**  
Check that the burner is installed properly. Check for defects in the burner.

---

## Flame is noisy, low or erratic

---

- **Is the gas supply fully turned on?**  
Check that the LPG fuel tank valve is fully open.
- **Is the gas supply in the LPG fuel gas tank low?**  
Check the gas level.
- **Does only one burner appear low?**  
Check and clean the burner ports if clogged or dirty. See "General Cleaning" section.
- **Is the gas supply hose bent or kinked?**  
Straighten the gas supply hose.
- **Is the flame noisy or lifting away from the burner?**  
Burner may be getting too much air. Check the air shutter adjustment, see "Check and Adjust Burners" section.
- **Is the burner flame mostly yellow or orange?**  
Grill may be in an area that is too windy, or not receiving enough air. Check the burner air inlets for obstructions. Check the air shutter adjustment, see "Check and Adjust the Burners" section.

---

## Excessive flare-ups

---

- **Is there excessive fat in the food being grilled?**  
Keep flame on low or turn one burner off.  
Keep the hood up when grilling to avoid excessive flare-ups.  
Move food to the warming rack until flames subside.  
To avoid damage to the grill, do not spray water on gas flames.

---

## Low Heat

---

### LPG Gas:

For outdoor grills using a LPG fuel tank, slowly open the tank valve.

**NOTE:** If flow limiting device activates, your grill may not light. If your grill does light, the flames will be low and will not heat properly.

1. Turn tank valve and all control knobs off and wait 30 seconds.
2. After shutting off the tank, very slowly open the tank valve and wait 5 seconds before lighting.
3. Light the burners one at a time. See "Lighting the Grill and side burner" section.

---

# ASSISTANCE

Before calling for assistance, please check "Troubleshooting." If you still need help, follow the instructions below.

When calling, please know the purchase date and the complete model and serial number of your appliance. This information will help us to better respond to your request.

### If you need replacement parts

If you have questions or need to order replacement parts, contact Customer Service Center at **0800-051-8916 (UK) or 800-7601 (Iceland)**.

---

## Accessories

### Rotisserie Kit

Order Part Number 790-0007A



---

## LIMITED WARRANTY (Model # 860-0030)

Warranty is to the original consumer-purchaser only that this product (Model# 860-0030) shall be free from defects in workmanship and materials after correct assembly and under normal and reasonable home use for the periods indicated below beginning on the date of purchase. The manufacturer reserves the right to require photographic evidence of damage, or that defective parts be returned, postage and or freight pre-paid by the consumer, for review and examination.

**Stainless steel tube burner:** 10-year LIMITED warranty against perforation, **Other burners** – 1 year

**Grids and grates:** 3 Year LIMITED warranty, does not cover dropping, chipping, scratching or surface damage

**Stainless steel parts:** 3 Year LIMITED warranty against perforation, does not cover cosmetic issue like surface corrosion, scratched and rust

**All other parts:** 1 Year LIMITED warranty (Includes, but not limited to, valves, frame, housing, cart, control panel, igniter, regulator, hoses); does not cover chipping, scratching, cracking surface corrosion, scratches or rust.

Upon consumer supplying proof of purchase as provided herein, Manufacturer will repair or replace the parts which are proven defective during the applicable warranty period. Parts required to complete such repair or replacement shall be free of charge to you except for shipping costs, as long as the purchaser is within the warranty period from the original date of purchase. The original consumer-purchaser will be responsible for all shipping charges of parts replaced under the terms of this limited warranty. This limited warranty is applicable in the United Kingdom and Iceland only. It is only available to the original owner of the product and is *not transferable*. Manufacturer requires reasonable proof of your date of purchase. Therefore, you should retain your sales receipt and/or invoice. If the unit was received as a gift, please ask the gift-giver to send in the receipt on your behalf, to the below address. Defective or missing parts subject to this limited warranty will not be replaced without registration or proof of purchase. This limited warranty applies to the functionality of the product **ONLY** and does not cover cosmetic issues such as scratches, dents, corrosions or discoloring by heat, abrasive and chemical cleaners or any tools used in the assembly or installation of the appliance, surface rust, or the discoloration of stainless steel surfaces. Surface rust, corrosion, or powder paint chipping on metal parts that does not affect the structural integrity of the product is not considered a defect in workmanship or material and is not covered by this warranty. This limited warranty will not reimburse you for the cost of any inconvenience, food, personal injury or property damage. If an original replacement part is not available, a comparable replacement part will be sent. You will be responsible for all shipping charges of parts replaced under the terms of this limited warranty.

### ITEMS MANUFACTURER WILL NOT PAY FOR:

- Service calls to your home.
- Repairs when your product is used for other than normal, single-family household or residential use.
- Damage resulting from accident, alteration, misuse, lack of maintenance/cleaning, abuse, fire, flood, acts of God, improper installation, and installation not in accordance with electrical or plumbing codes or use of products not approved by the manufacturer.
- Any food loss due to product failures.
- Replacement parts or repair labor costs for units operated outside the United Kingdom or Iceland.
- Pickup and delivery of your product.
- Postage fees or photo processing fees for photos sent in as documentation.
- Repairs to parts or systems resulting from unauthorized modifications made to the product.
- The removal and/or reinstallation of your product.
- Shipping cost, standard or expedited, for warranty/non warranty and replacement parts.

### DISCLAIMER OF IMPLIED WARRANTIES; LIMITATION OF REMEDIES

*Repair or replacement of defective parts is your exclusive remedy* under the terms of this limited warranty. Manufacturer will not be responsible for any consequential or incidental damages arising from the breach of either this limited warranty or any applicable implied warranty, or for failure or damage resulting from acts of God, improper care and maintenance, grease fire, accident, alteration, replacement of parts by anyone other than Manufacturer, misuse, transportation, commercial use, abuse, hostile environments (inclement weather, acts of nature, animal tampering), improper installation or installation not in accordance with local codes or printed manufacturer instructions.

THIS LIMITED WARRANTY IS THE SOLE EXPRESS WARRANTY GIVEN BY THE MANUFACTURER. NO PRODUCT PERFORMANCE SPECIFICATION OR DESCRIPTION WHEREVER APPEARING IS WARRANTED BY MANUFACTURER EXCEPT TO THE EXTENT SET FORTH IN THIS LIMITED WARRANTY. ANY IMPLIED WARRANTY PROTECTION ARISING UNDER THE LAWS OF ANY STATE, INCLUDING IMPLIED WARRANTY OF MERCHANTABILITY OR FITNESS FOR A PARTICULAR PURPOSE OR USE, IS HEREBY LIMITED IN DURATION TO THE DURATION OF THIS LIMITED WARRANTY.

Neither dealers nor the retail establishment selling this product has any authority to make any additional warranties or to promise remedies in addition to or inconsistent with those stated above. Manufacturer's maximum liability, in any event, shall not exceed the documented purchase price of the product paid by the original consumer. This warranty only applies to units purchased from an authorized retailer and or re-seller.

NOTE: Some states do not allow an exclusion or limitation of incidental or consequential damages, so some of the above limitations or exclusions may not apply to you; this limited warranty gives you specific legal rights as set for herein. Rights may vary depending on where you reside.

If you wish to obtain performance of any obligation under this limited warranty, you should write to:

**Nexgrill Customer Relations  
14050 Laurelwood Pl  
Chino, CA 91710**

*All consumer returns, parts orders, general questions, and troubleshooting assistance can be acquired by calling 0800-051-8916 (UK) or 800-7601 (Iceland).*

# Package Parts List

1

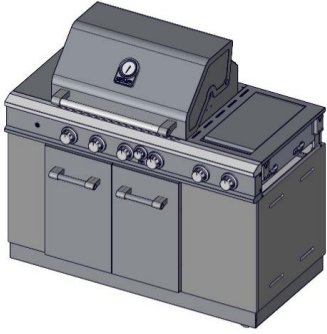

2

x2

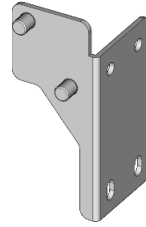

3

x2

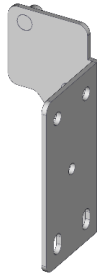

4

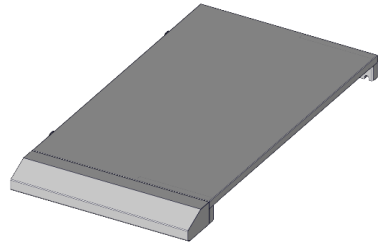

5

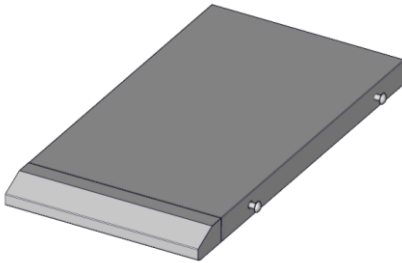

6

x4

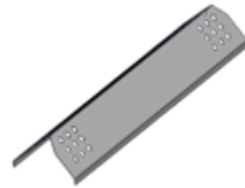

7

x2



8

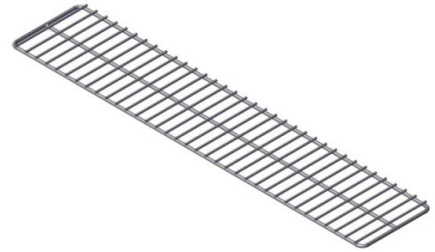

9

x2



10

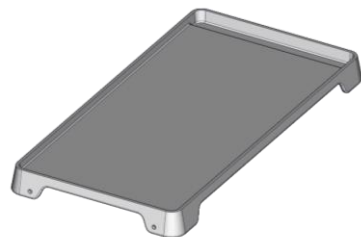

## Package Parts List

11 (x2)

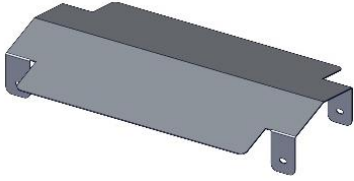

12 (x2)



13 (x5)

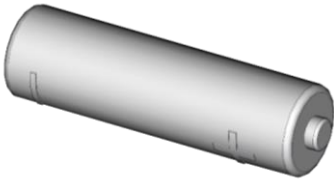

14 (x2)

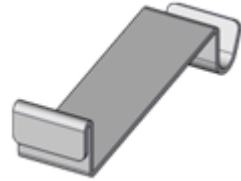

15

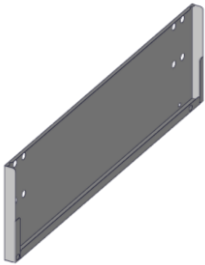

16

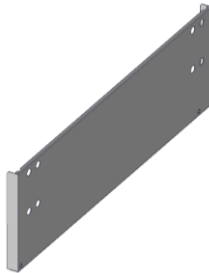

17



## Hardware Package List

Truss Head Screw  
1/4-20 x 1/2

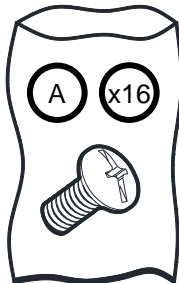

Truss Head Screw  
5/32-32 x 15/16"

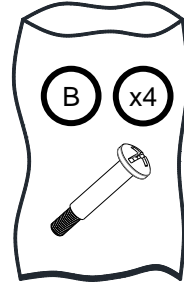

## Tools needed

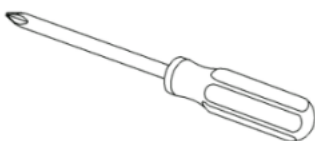

Some parts come with screws pre-installed. Loosen and tighten for final assembly.

# Assembly Instructions

1.

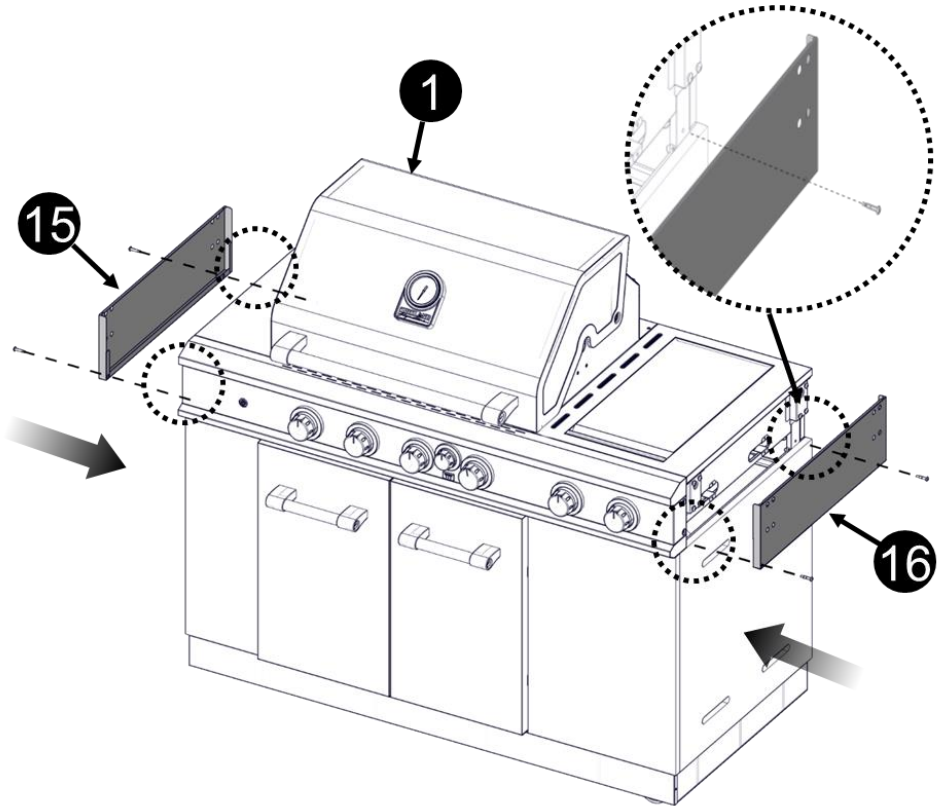
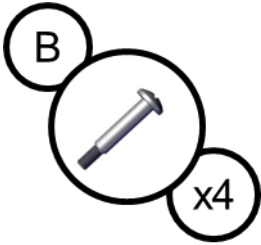

2.

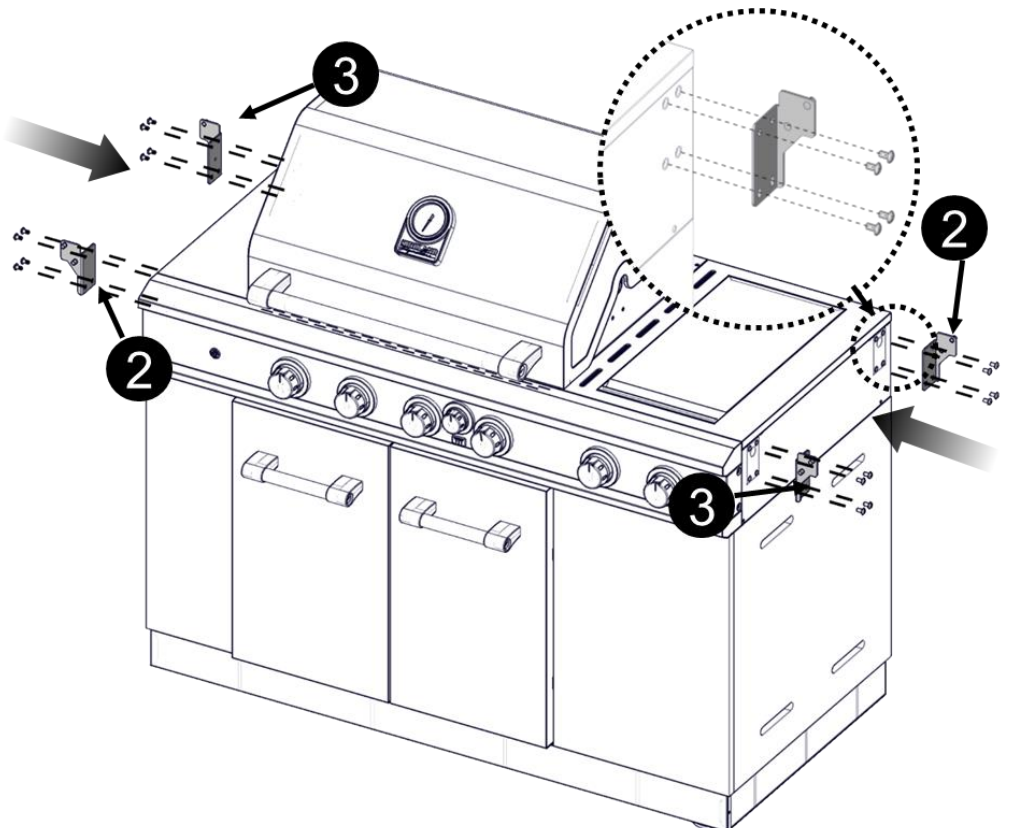
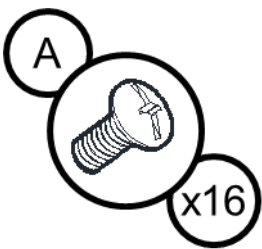

3.

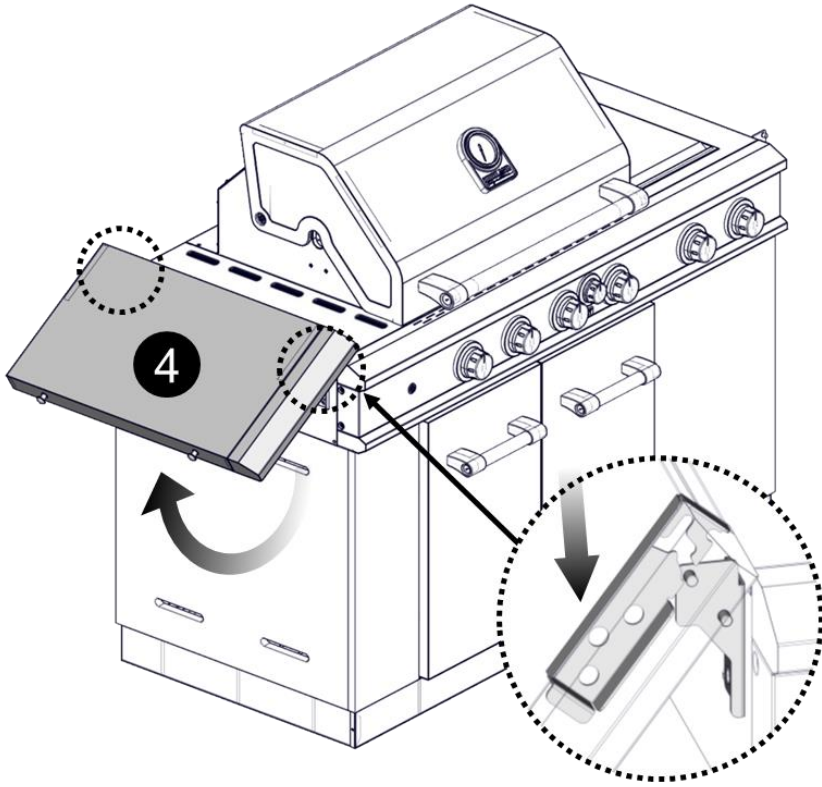

4.

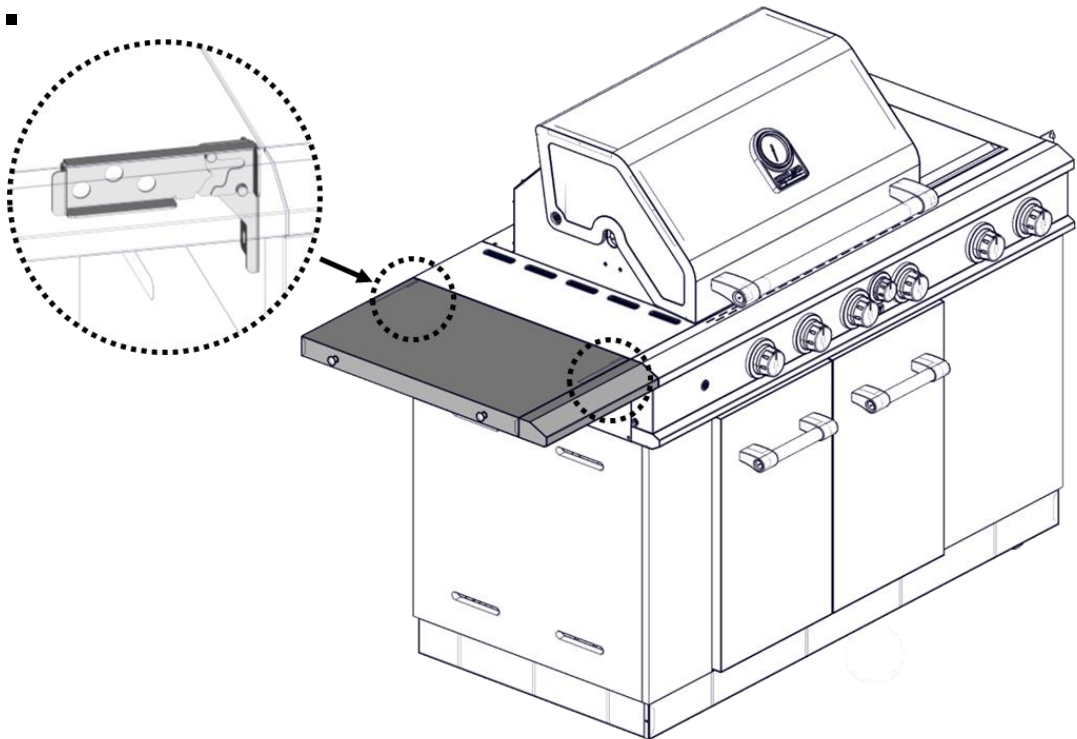

5.

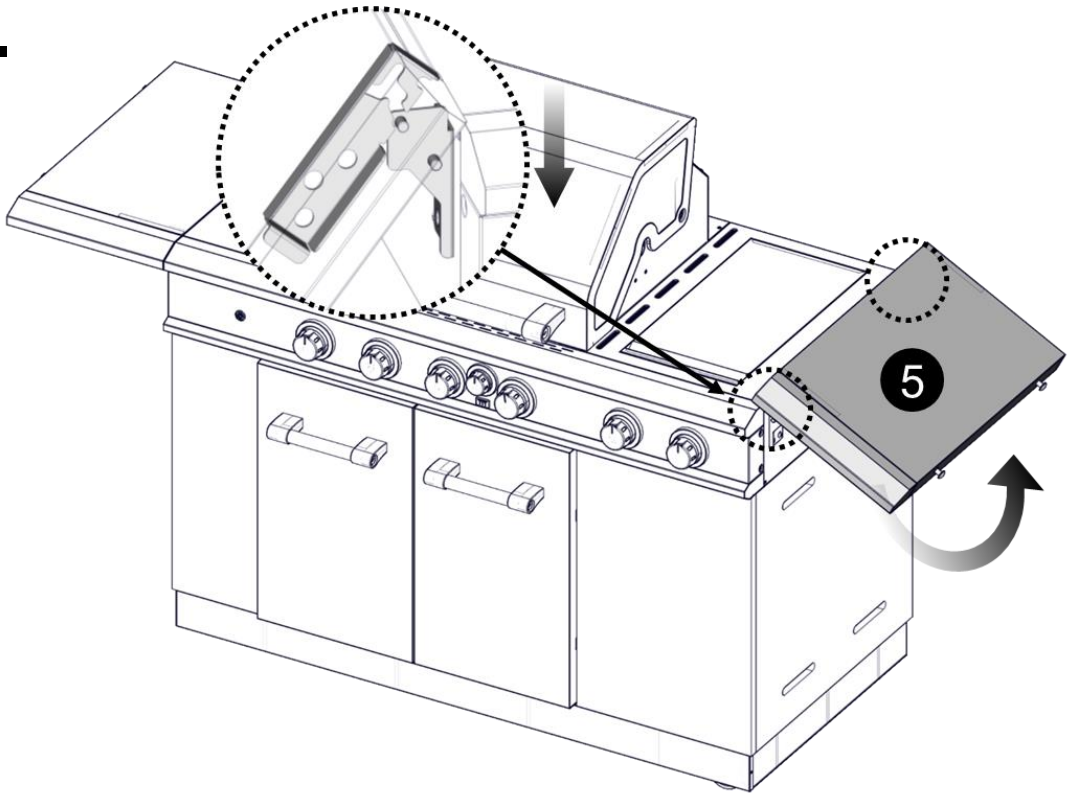

6.

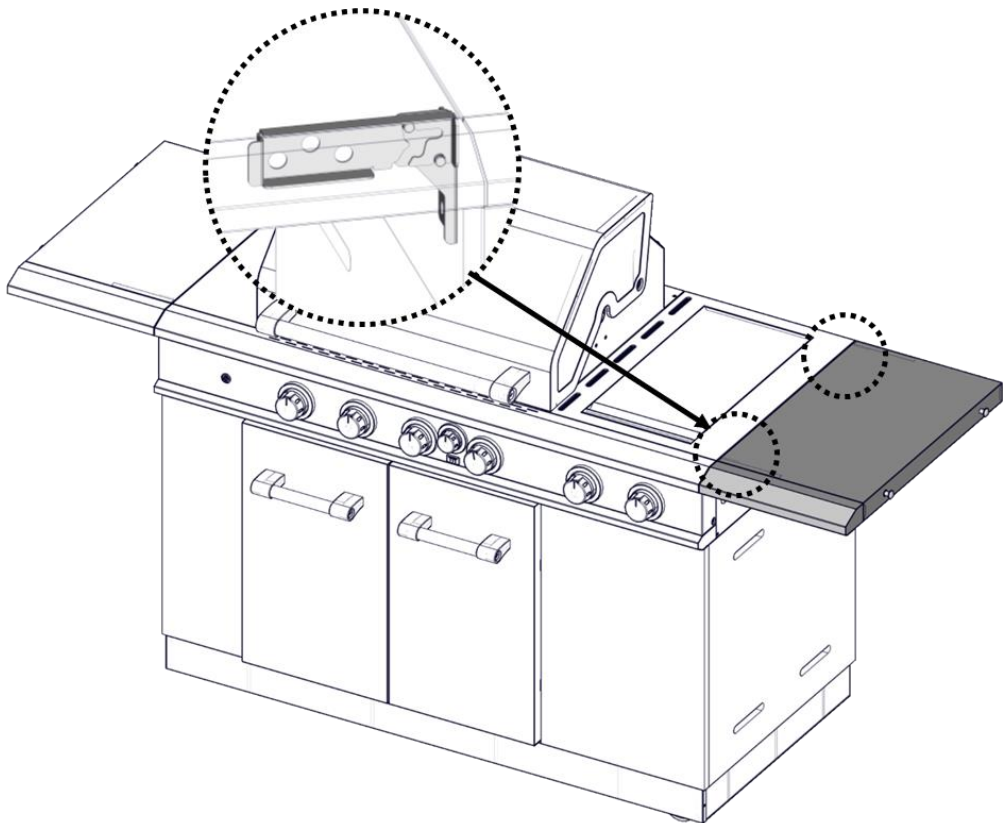

7.

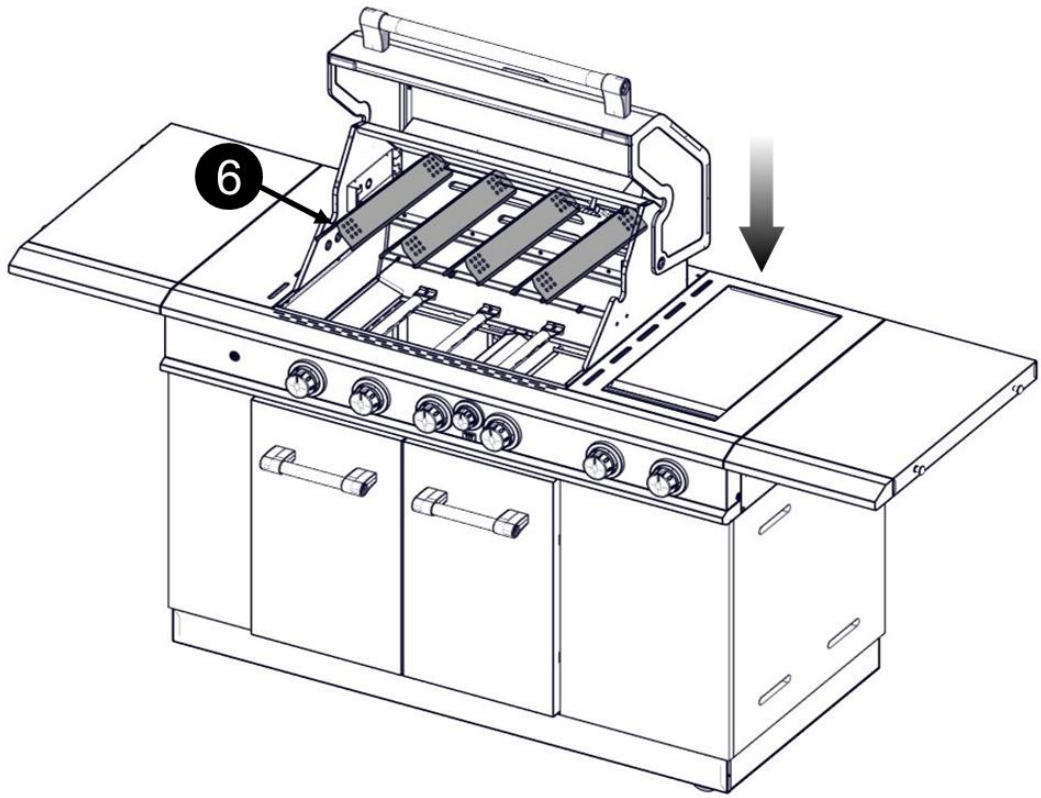

8.

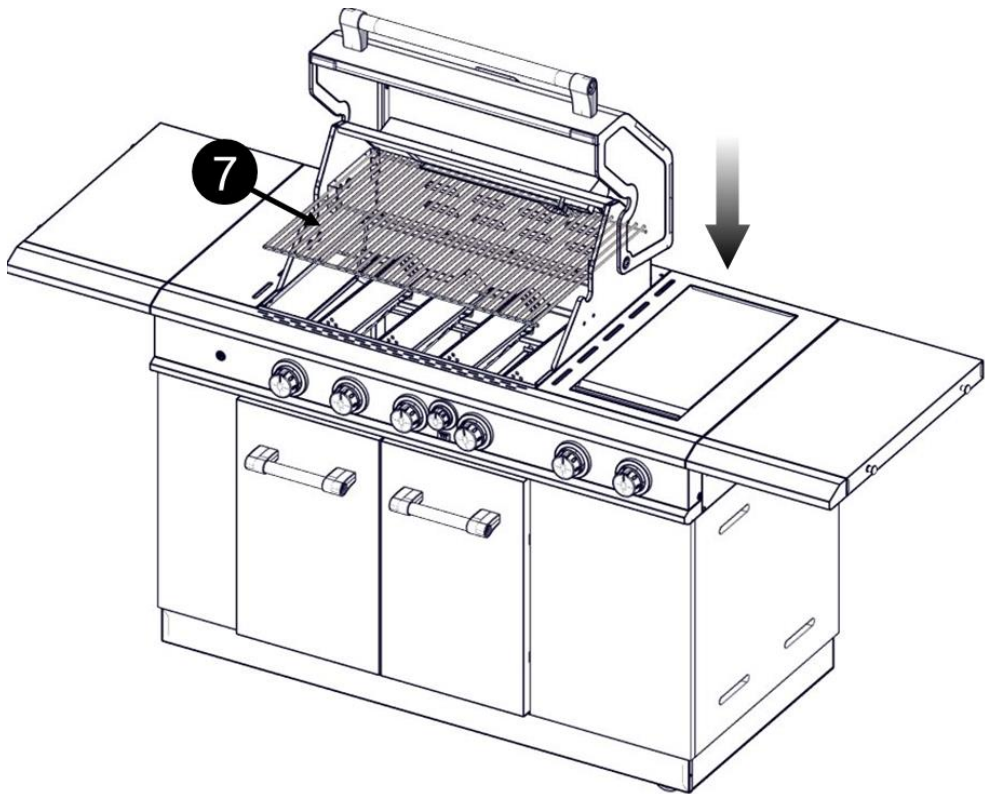



9.

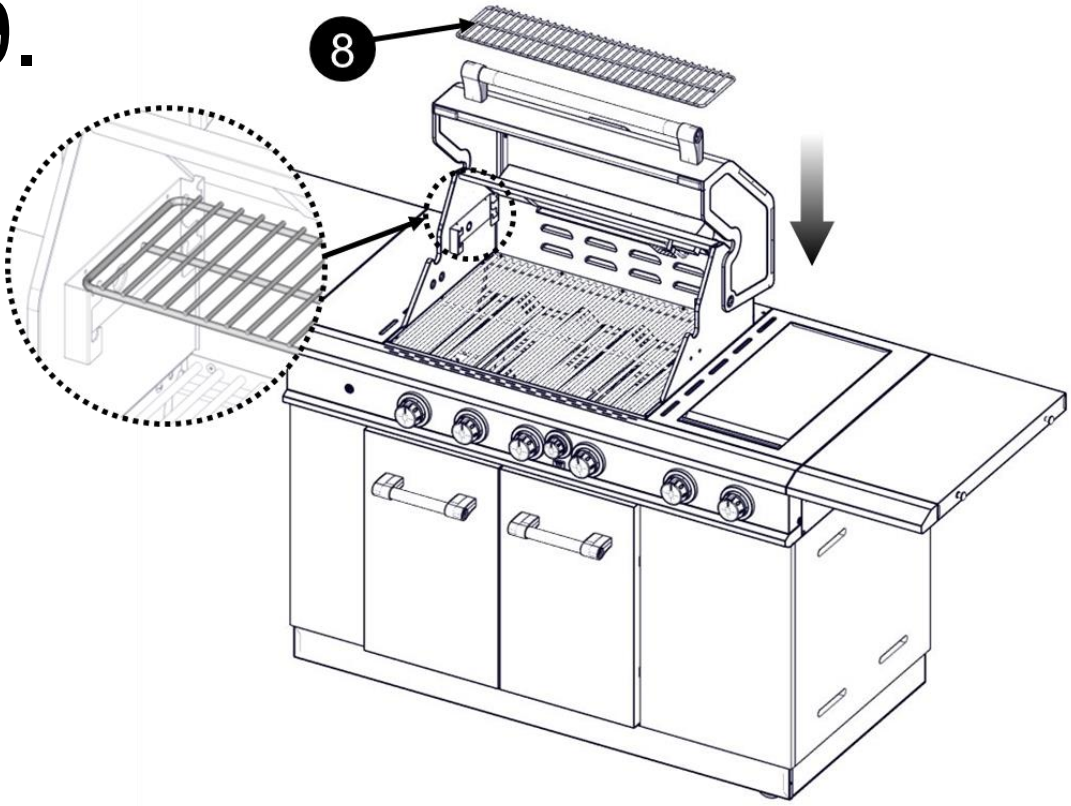

10.

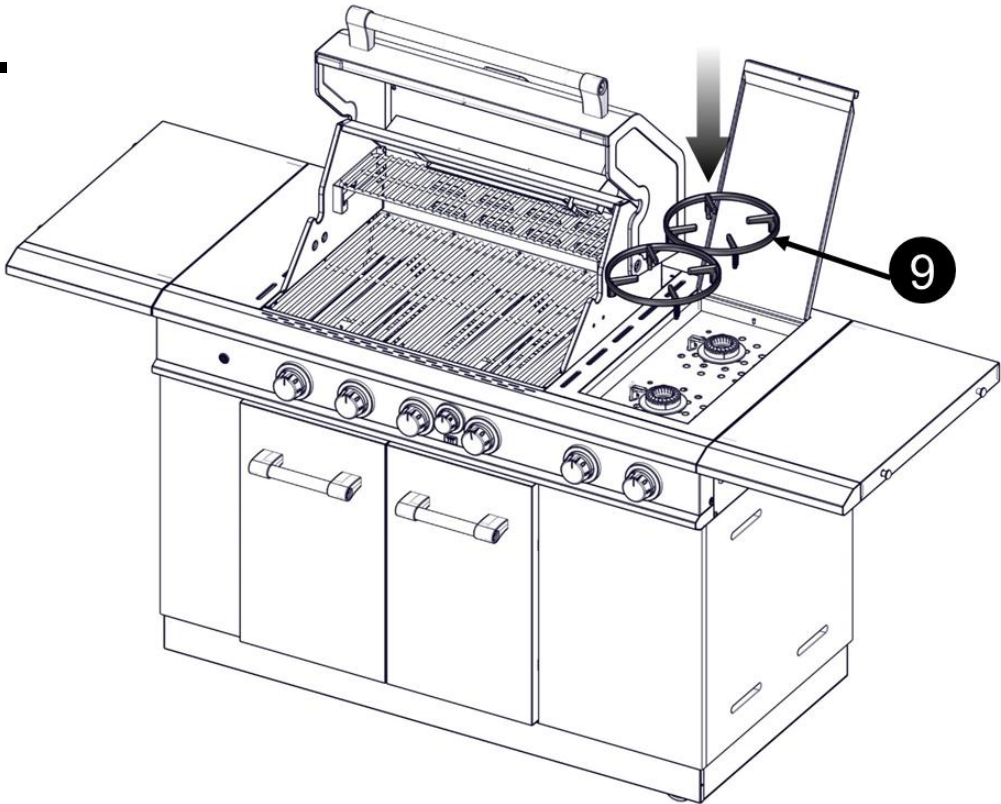

11.

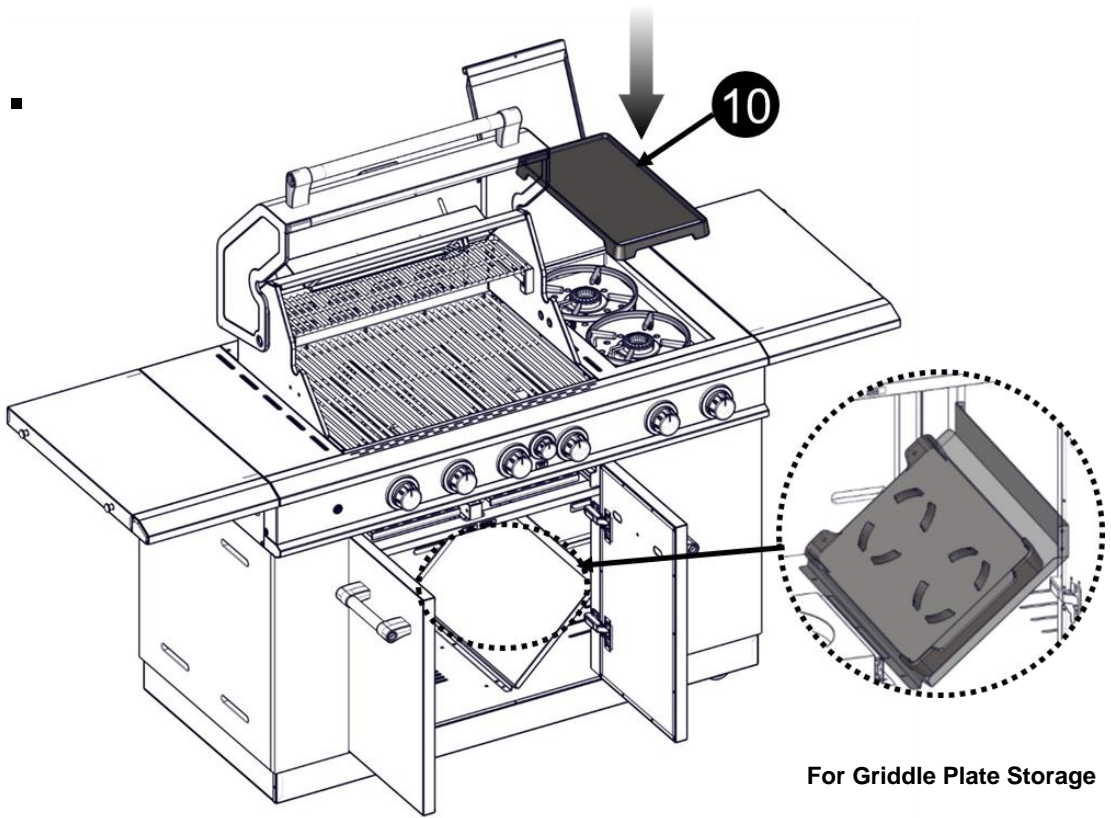

12.

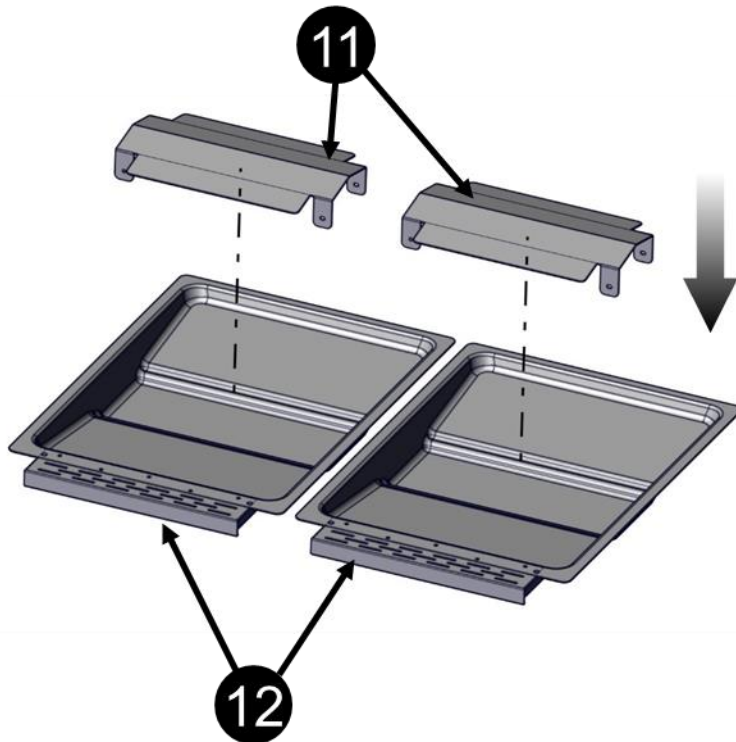

13.

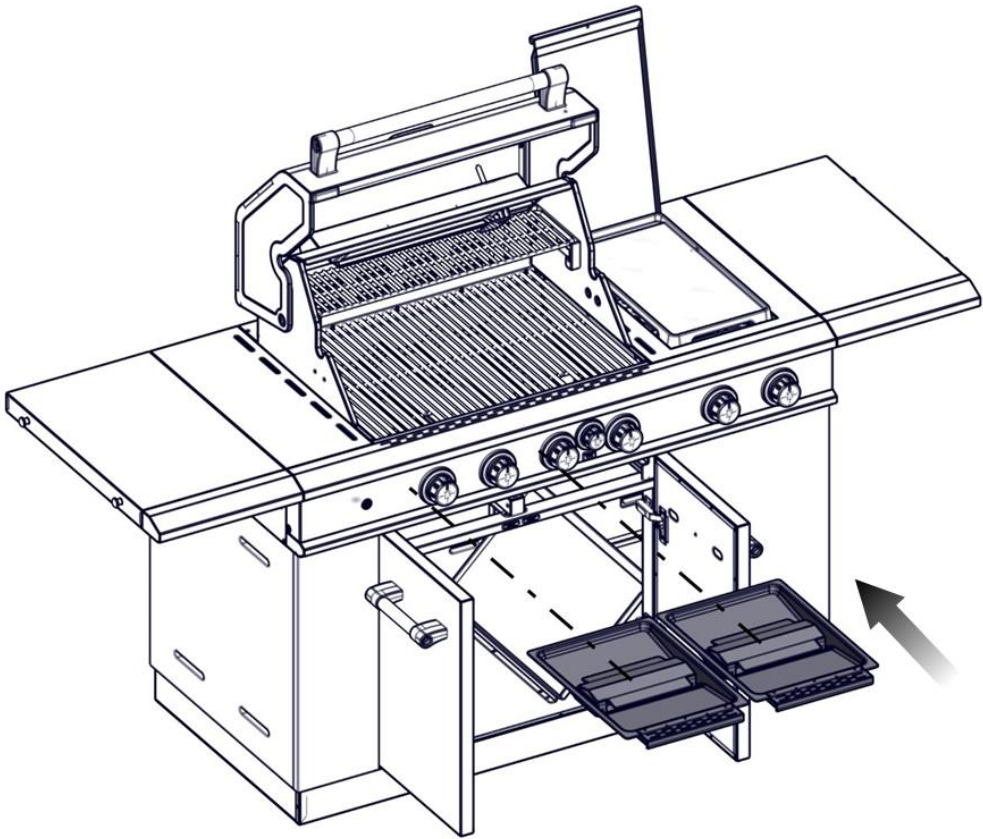

14.⚠

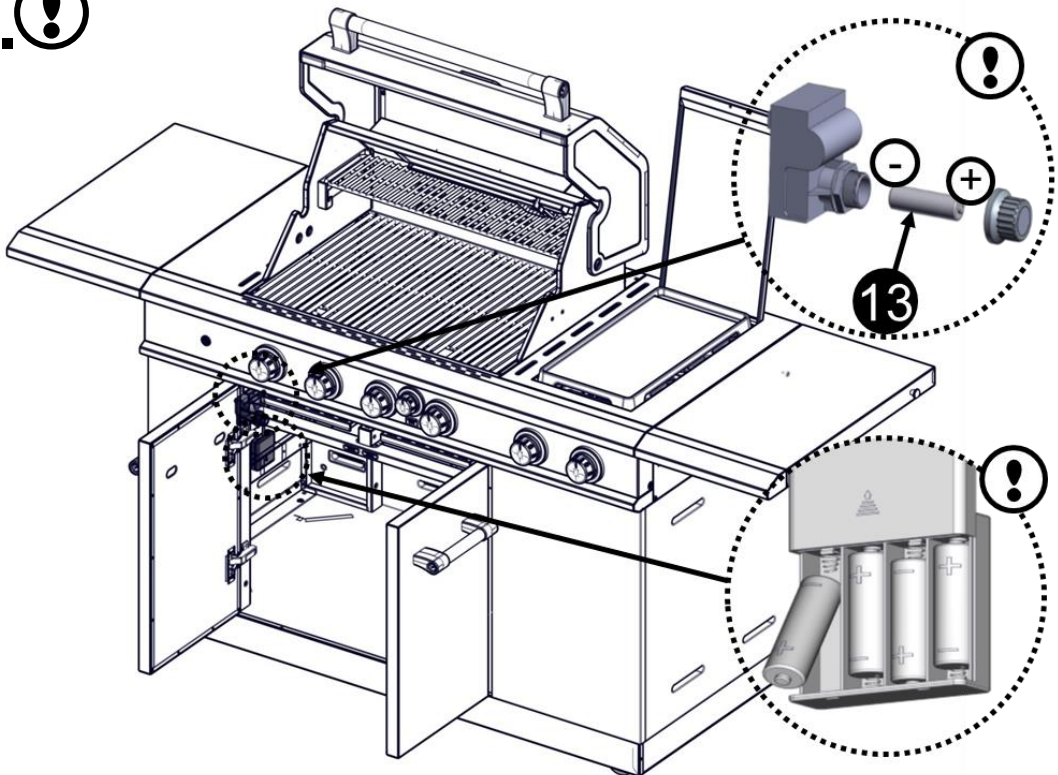

15.

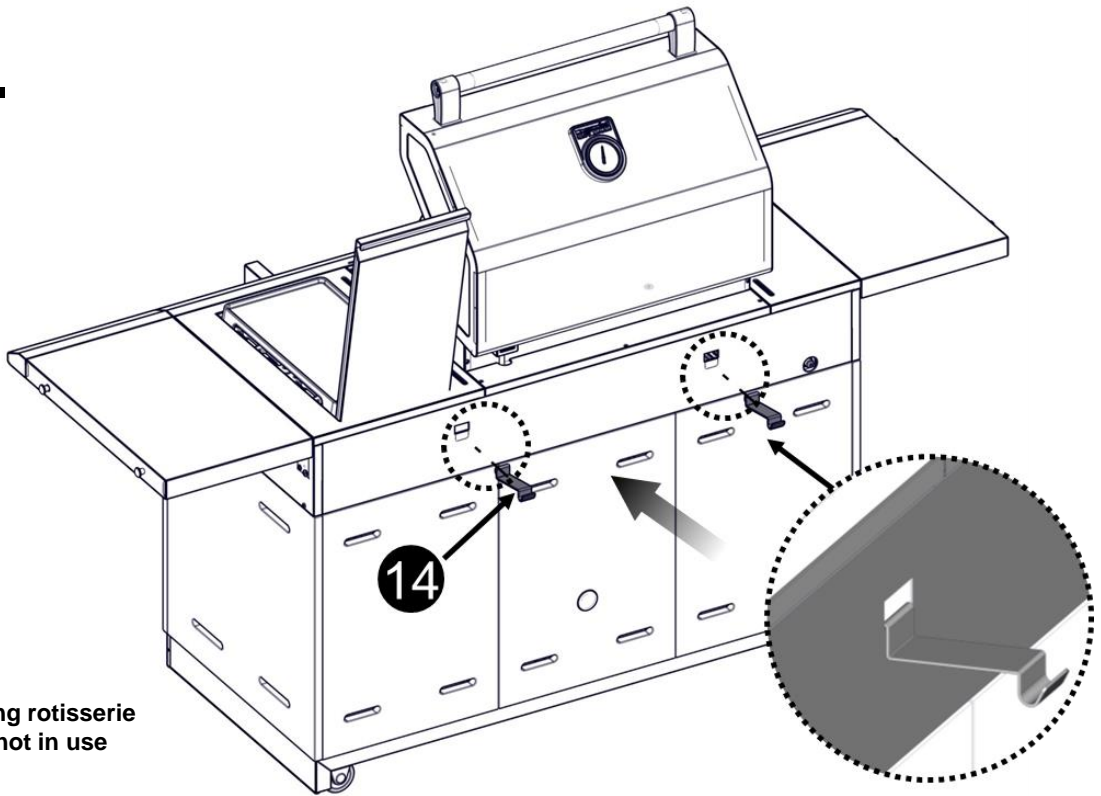

For placing rotisserie  
kit when not in use

16.

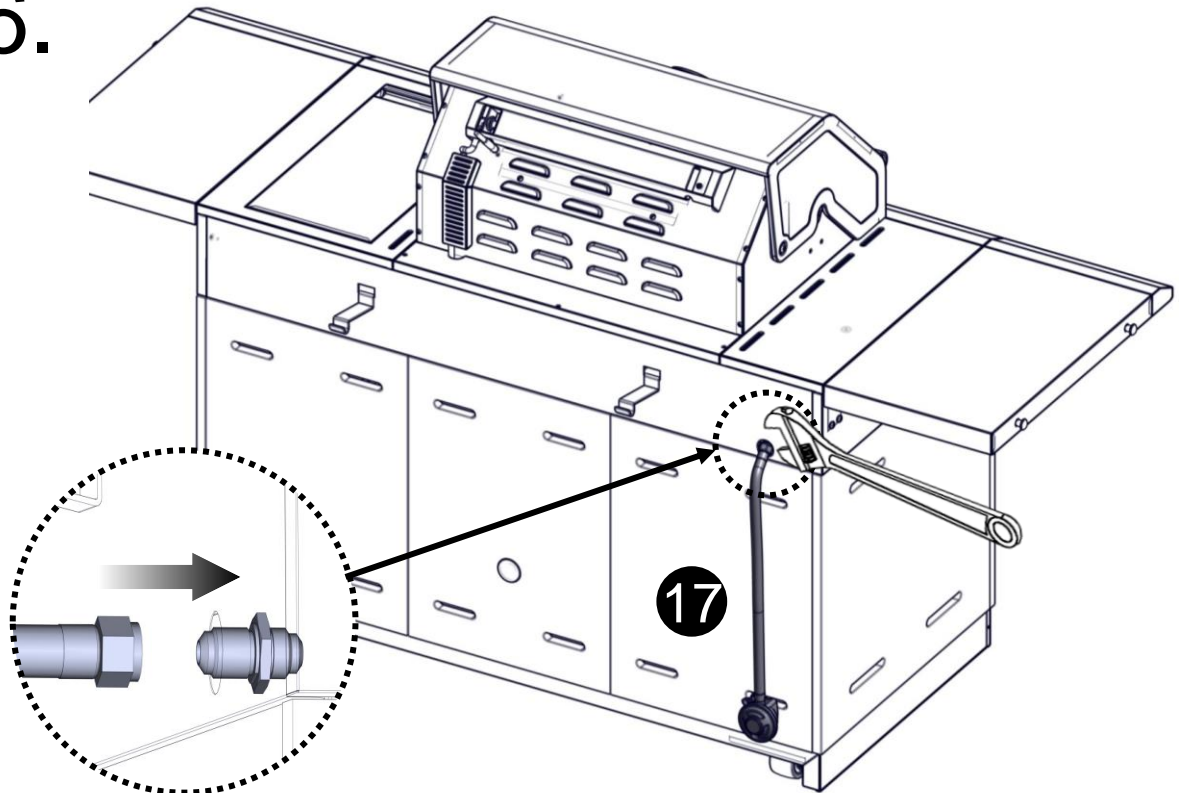

17.

SE/ICE

SP

UK

Propane tank is not included

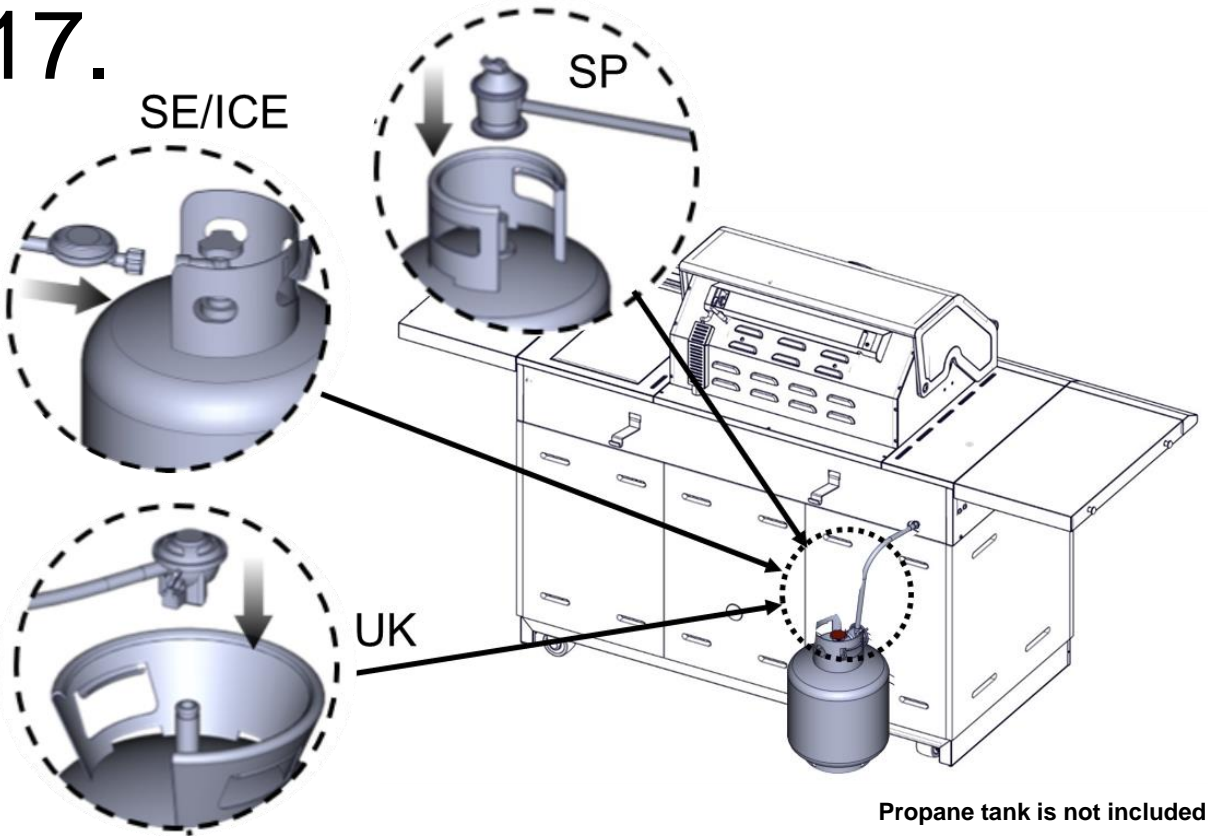

18.

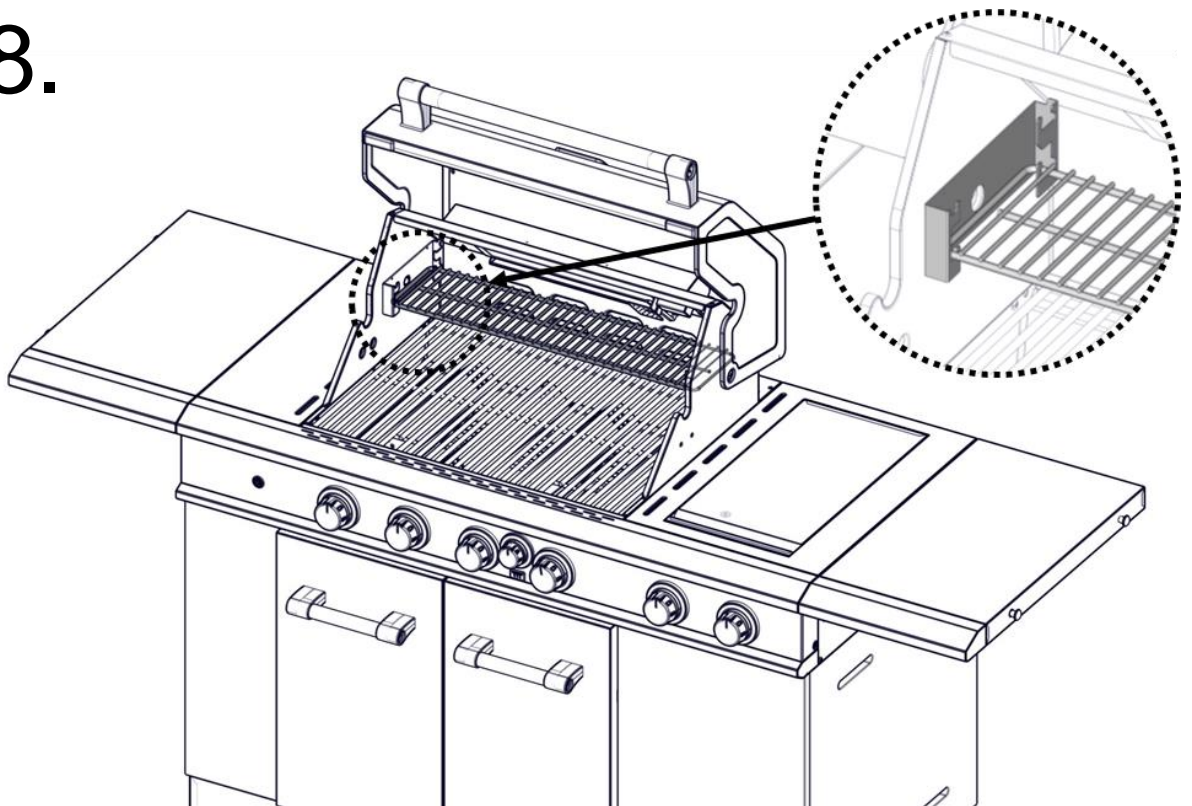

19.

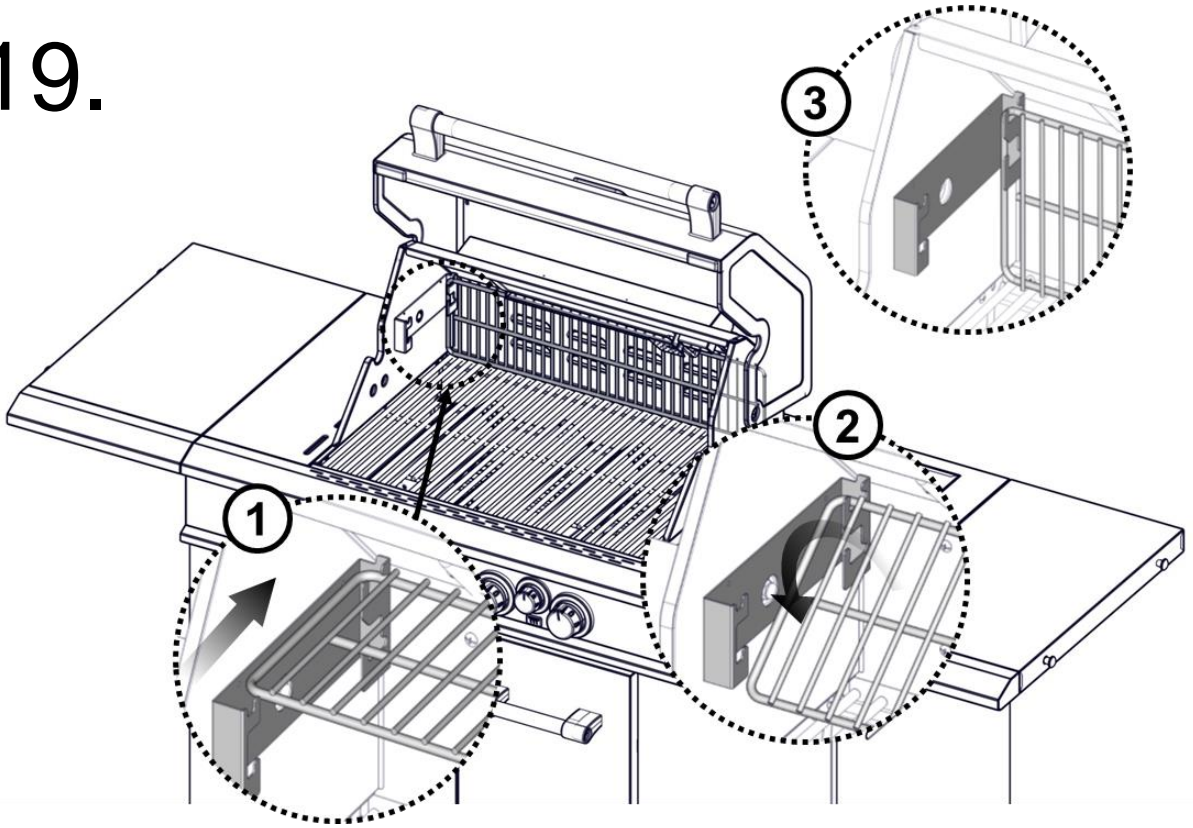

20.

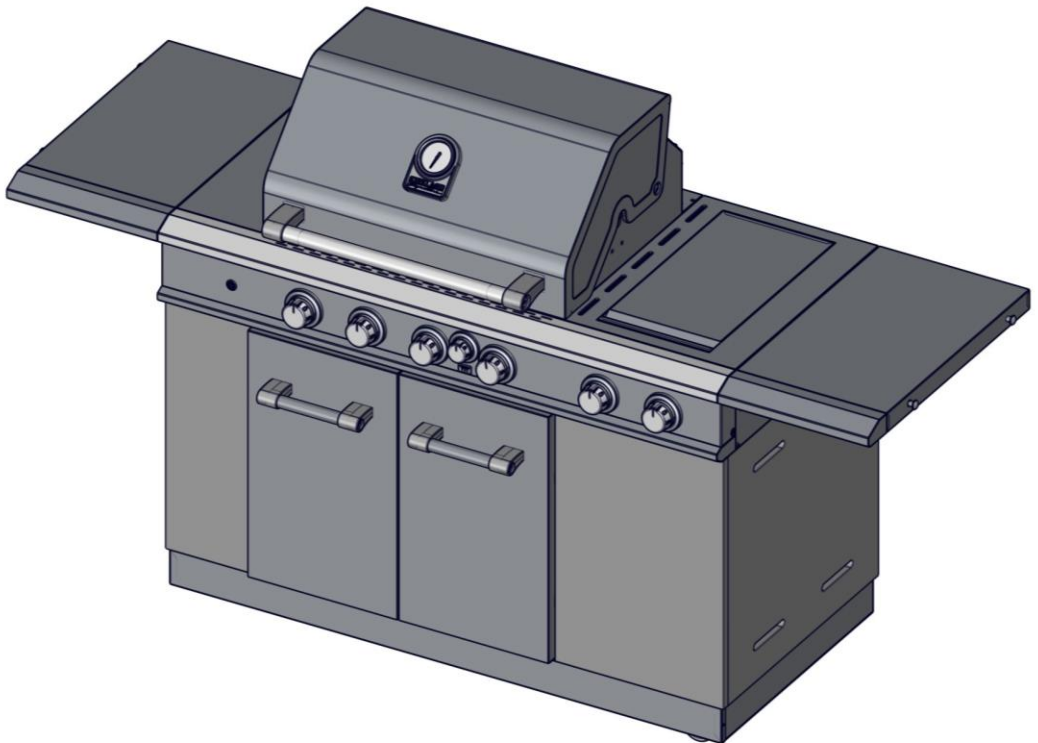

# Replacement Parts

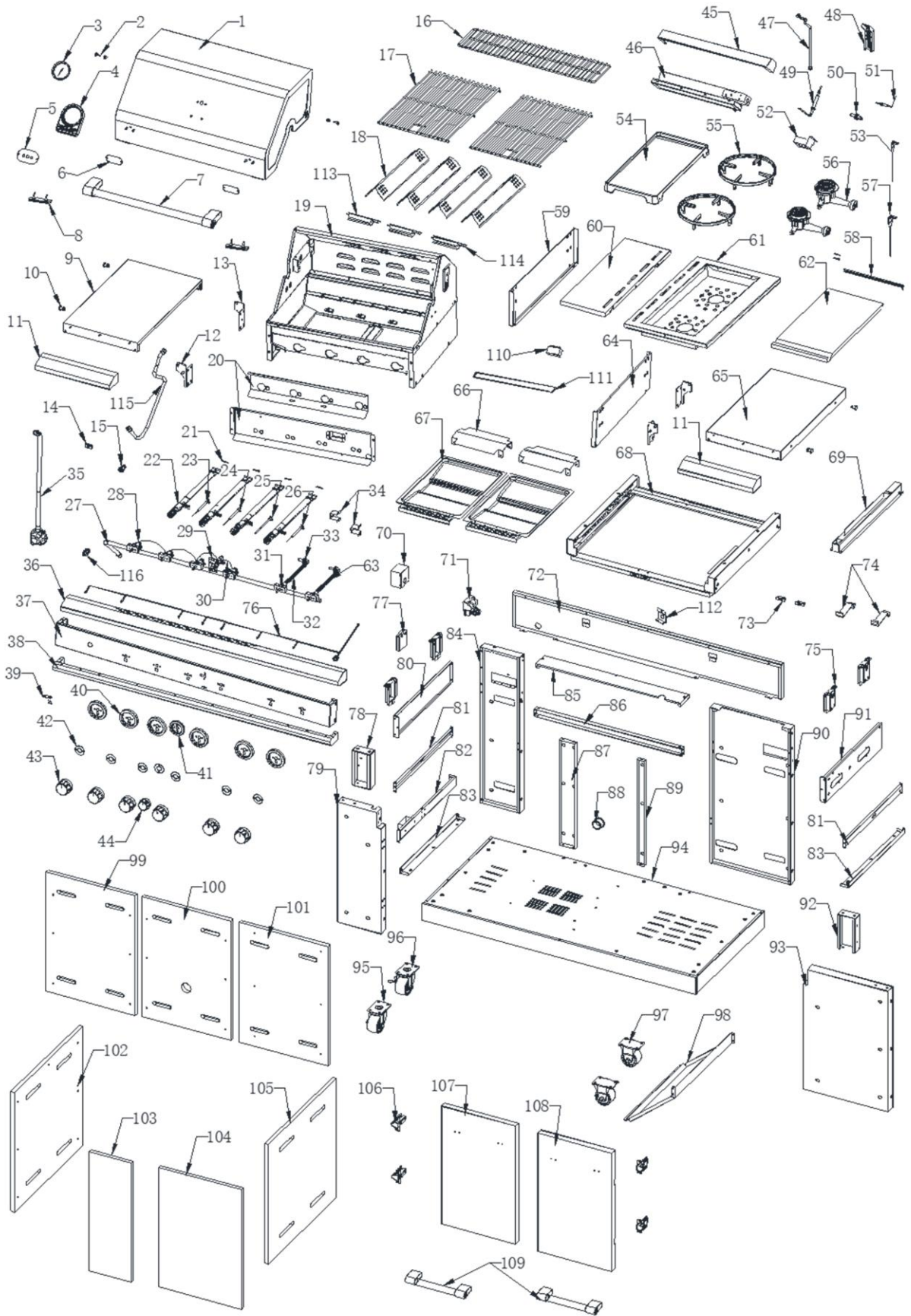

## Parts List

No.	Part (Description)	Warranty coverage (year)	QTY	No.	Part (Description)	Warranty coverage (year)	QTY
1	Main lid	3	1	31	Searing side burner gas valve	1	2
2	Main lid screw	1	2	32	Side burner flex Gas line A	1	1
3	Temperature gauge	1	1	33	Side burner orifice w/brass elbow	1	2
4	Logo and Temperature gauge housing	1	1	34	Side burner orifice fix panel	1	2
5	Temperature gauge seal piece	1	1	35	Regulator, LP	1	1
6	Main lid Handle Heat Insulating Spacer	1	2	36	Control panel trim piece(upper)	1	1
7	Main lid handle assembly	3	1	37	Main control panel	3	1
8	Lid bumpers	1	2	38	Control panel trim piece (lower)	1	1
9	Foldable side shelf, left	3	1	39	Main control panel fix panel	1	1
10	Tool Hook	1	4	40	Bezel A	1	6
11	Side shelf front trim pieces	1	2	41	Bezel B (small)	1	1
12	Foldable side shelf Bracket A	3	2	42	LED Light	1	7
13	Foldable side shelf Bracket B	3	2	43	Control knob A	1	6
14	Top sear burner badge	1	1	44	Control Knob B (small)	1	1
15	LED Light switch	1	1	45	Top sear burner heat shield	1	1
16	Warming rack	3	1	46	Top sear burner	1	1
17	Cooking grid with hole	3	2	47	Top sear burner flex Gas line	1	1
18	Flame tamer	3	4	48	Flex Gas line cover	1	1
19	Main burner bowl assembly	Non-replaceable	1	49	Top sear burner igniter wire	1	1
20	Control panel heat shield	1	1	50	Top sear burner orifice w/brass elbow	1	1
21	Burner pin assembly	1	6	51	Top sear burner thermocouple	1	1
22	Main burner	10	4	52	Top sear burner igniter bracket	1	1
23	Main burner igniter wire A	1	1	53	Side burner igniter pin A	1	1
24	Main burner igniter wire B	1	1	54	Side burner cooking griddle	3	1
25	Main burner igniter wire C	1	1	55	Side burner cooking grid	3	2
26	Main burner igniter wire D	1	1	56	Cast iron burner	1	2
27	Main manifold	1	1	57	Side burner igniter pin B	1	1
28	Main gas valve	1	4	58	Side burner lid screw	1	2
29	Top sear gas valve	1	1	59	Cart trim piece , left	1	1
30	Igniter junction wire	1	1	60	Left side shelf	1	1



## Parts List

No.	Part (Description)	Warranty coverage (year)	QTY	No.	Part (Description)	Warranty coverage (year)	QTY
61	Right side burner shelf	1	1	91	Cart trim piece, right	1	1
62	Side burner lid	1	1	92	Front fixed faceplate, right	1	1
63	Side burner flex Gas line B	1	1	93	Cart front fixed panel, right	1	1
64	Cart trim piece , right	1	1	94	Bottom panel	1	1
65	Foldable side shelf, right	1	1	95	Swivel caster	1	1
66	Grease tray heat tent	1	2	96	Swivel caster with brake	1	1
67	Grease tray assembly	1	2	97	Caster	1	2
68	Cart frame assembly	1	1	98	Side burner cooking griddle shelf	1	1
69	Grease channel (middle)	1	1	99	Faux stone back panel, left	1	1
70	Electric igniter module heat shield	1	1	100	Faux stone back panel,middle	1	1
71	Electric igniter module	1	1	101	Faux stone back panel,right	1	1
72	Cart trim piece, rear	1	1	102	Faux stone side panel, left	1	1
73	Door magnet	1	2	103	Faux stone front panel, left	1	1
74	Bracket	3	2	104	Faux stone front panel, right	1	1
75	Foldable side shelf Bracket	3	4	105	Faux stone side panel, right	1	1
76	LED lights wire	1	1	106	Door hinge	1	4
77	Battery box	1	1	107	Door, left	3	1
78	Front fixed faceplate, left	1	1	108	Door, right	3	1
79	Cart front fixed panel, left	1	1	109	Door handle assembly	3	2
80	Cart trim piece, left	1	1	110	Top sear burner thermocouple bracket	1	1
81	Frame support, top	1	2	111	Top sear burner baffle, bottom	1	1
82	Gas cylinders baffle	1	1	112	Adapter fixed plate	1	1
83	Frame support, bottom	1	2	113	Cross Channel assembly A	1	2
84	Cart back fixed panel, left	1	1	114	Cross Channel assembly B	1	1
85	Main firebox trim piece, rear	1	1	115	Flex Gas line assembly	1	1
86	Cart frame assembly	1	1	116	Adapter	1	1
87	Cart frame supporter, rear	1	1		Grill cover	1	1
88	NG hole rubber plug	1	1		Manual	N/A	1
89	Cart frame supporter, rear	1	1		Preassembly hardware pack		1
90	Cart back fixed panel, right	1	1				

Costco Wholesale UK Ltd /  
Costco Online UK Ltd  
Hartspring Lane  
Watford, Herts  
WD25 8JS  
United Kingdom  
01923 213113  
[www.costco.co.uk](http://www.costco.co.uk)

Costco Wholesale Iceland ehf.  
Kauptún 3-7, 210 Gardabaer  
Iceland  
[www.costco.is](http://www.costco.is)

Limited warranty provided by manufacturer