



MeacoDry

Arete[®] Two^{18L}

Dehumidifier and Air Circulator

Arete: Greek goddess of "Excellence in all things"; in Ancient Greek Mythology

Instruction Manual

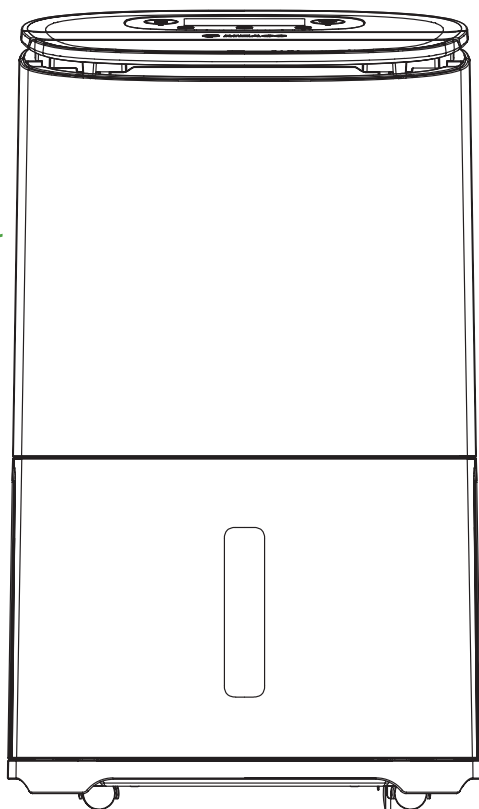

Thank you for choosing Meaco

Thank you for choosing Meaco, we really appreciate it. After the success of the Arete® One range, we've built Arete® Two: a range of combined dehumidifiers and air purifiers for customers who want even more control over the humidity in their home. We took the time to design a dehumidifier that blends into your home without compromising on its performance. You'll soon wonder how you managed without it.

This manual contains important information on the use and care of your dehumidifier. Please take some time to read this manual to take full advantage of your dehumidifiers' many benefits and features.

Contents

Safety information	1
Register your Meaco warranty	5
Meaco app	6
What's included	7
Product identification	8
First steps	9
Operation	11
Water tank	14
Continuous drainage	15
Maintenance	17
Storing	19
Troubleshooting	19
Meaco customer care	21
Specifications	22
Warranty terms & conditions	23

Safety information

Important safety instructions



Keep children away: Do not allow children to play with or around this unit, as it could result in injury. Be sure the dehumidifier is inaccessible to children when not attended. This dehumidifier is not intended for use by persons (including children) with reduced physical, sensory or mental capabilities, or lack of experience and knowledge, unless they have been given supervision or instruction concerning use of the dehumidifier by a person responsible for their safety.

Keep unit grounded: Always operate the dehumidifier with a grounding plug and a grounded electrical outlet. A grounding plug is an essential safety feature that helps reduce the risk of shock or fire.

Protect power cord from damage: Never operate a dehumidifier with a damaged power cord, as this may lead to electrical or fire hazards. If the power supply cord is damaged, it must be replaced by a cord of the same type and amperage rating.

Extension cords: Extension cords must be grounded and able to deliver the appropriate voltages to the dehumidifier.

Handle with care: Do not drop, throw or crash the dehumidifier. Rough treatment can damage the components or wiring and create a hazardous condition.

Run on a stable surface: Always operate the dehumidifier on a stable, level surface, for example the floor or a strong counter, so that the dehumidifier cannot fall and cause injury.

Keep air intakes clear: Do not clog or block the air intakes by placing the dehumidifier too close to curtains, walls or anything that will restrict the air inlet. This may cause the unit to overheat and result in a fire or electrical hazard.

Keep electrical components dry: Never allow water inside the dehumidifier's electrical components. If these areas become wet for any reason, thoroughly dry them before using the dehumidifier. If in doubt, do not use the dehumidifier and consult a qualified electrician or a Meaco approved engineer.

Domestic use only: This dehumidifier is designed for domestic use only and should not be used in commercial environments.

The operator must make the operating instruction available for the user and make sure that the user understands the manual.



The MeacoDry Arete® Two Dehumidifier and Air Purifier uses the new R290 refrigerant gas to comply with European Environmental Directives. R290 is kinder to the environment and is part of attempts to reduce global warming as it has a low greenhouse effect (GWP).

When using the MeacoDry Arete® Two Dehumidifier and Air Purifier you must take into account the following:

- This dehumidifier uses about 65 (18L) grams of R290 refrigerant, which is flammable. Therefore, it is part of a sealed system and must only be serviced by a trained Meaco engineer.
- Do not use or store this dehumidifier in a room smaller than 4m² to prevent a fire or explosion hazard if there is a leak of refrigerant and the gas comes into contact with an ignition source.
- Do not use it in a room with any continuous sources of ignition, for example open flames, gas fires or hobs, cigarettes or any other sources of ignition.
- If the dehumidifier is installed, operated or stored in a non-ventilated area, then the room must be designed to prevent the accumulation of refrigerant leaks resulting in a risk of fire or explosion due to ignition of the refrigerant caused by electric heaters, cookers, or other sources of ignition.
- R290 refrigerant gas is odourless.
- Do not puncture either during the dehumidifiers working life or after. At the end of life dispose of following local recycling regulations.
- If there is any damage to the dehumidifier then do not use it and contact Meaco or your retailer.
- As with all dehumidifiers, always keep upright and leave the dehumidifier standing upright for six hours before using it upon receipt.



Failure to comply with these instructions could result in fire, damage to property, serious injury or potentially death.

Individuals who operate or work on the refrigerant circuit must have the appropriate certification issued by a national accredited organisation that ensures competence in handling flammable refrigerants according to a specific evaluation recognised by national associations in the industry and compliant with the latest R290 guidance.

Servicing should only be carried out by a Meaco approved engineer using original Meaco parts to prevent damage to the dehumidifier and potential injury to the engineer.

Instructions about the WEEE



Correct disposal of this product (Waste Electrical & Electronic Equipment)

This marking indicates that this product or accessories should not be disposed of with other household waste at the end of their working life. To prevent possible harm to the environment or human health from uncontrolled waste disposal, please separate these items from other types of waste and recycle them responsibly. Users should contact either the retailer where they purchased this product, or their local government, for details of where and how they can take these items for environmentally safe recycling.

Declaration of conformity

Hereby, Meaco declares that this radio equipment is in compliance with Directive 2014/53/EU and with the relevant statutory requirements. The full text of the EU declaration of conformity and the UK declaration of conformity is available at the following internet address:
www.meaco.com/pages/compliance-data.

Wiring instructions

Should it be necessary to change the plug, please note the wires in the mains lead are coloured in accordance with the following code:

Blue: Neutral

Brown: Live

Green and yellow: Earth

As the colours of the wires in the mains lead of this appliance may not correspond with the coloured markings identifying the terminals in your plug, proceed as follows:

1. The **BLUE** wire is the **NEUTRAL** and must be connected to the terminal which is marked with the letter **N** or coloured **BLACK**.
2. The **BROWN** wire is the **LIVE** and must be connected to the terminal which is marked with the letter **L** or coloured **RED**.
3. The **GREEN/YELLOW** is the **EARTH** and must be connected to the terminal which is marked with the letter **E** or coloured **GREEN** or **GREEN/YELLOW**.
4. Always ensure that the cord grip is positioned and fastened correctly.
5. Only ever use the same fuse as fitted in the original product. If in doubt please contact Meaco first or a qualified electrician.

Example wiring for a Standard British Plug:

Note – The Earth Terminal is marked with the letter E or Earth Symbol (⊕).

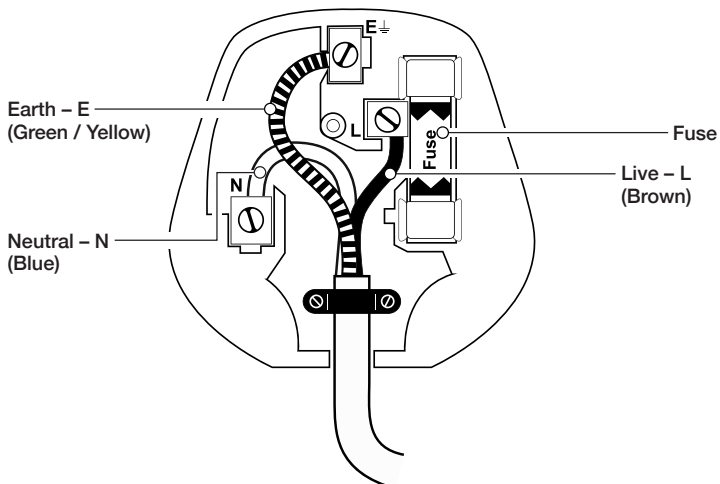

Register your Meaco warranty

Your Meaco dehumidifier comes with a free five year warranty. Simply register your details online and you'll be covered for parts and labour for five years from the date of purchase, subject to the terms and condition of the warranty. As a thank you, you will be entered into our monthly free prize draw to help support the David Shepherd Wildlife Foundation.

Where to find your dehumidifiers serial number

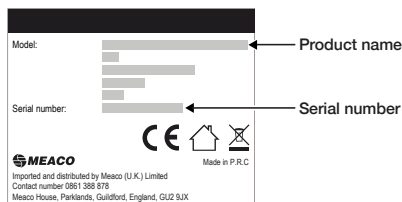

The serial number can be found on the rating label on the back of your dehumidifier.

Remember to keep a copy of your purchase receipt safe, you will need to show this to our Customer Service team should you need to make a warranty claim.

Ways to register your Meaco warranty



Register online

Visit our website to register your free five year warranty online:

<https://www.meaco.com/pages/register-your-warranty>

Register by phone

Call our Customer Service team to register your free five year warranty over the phone: 01483 234900

Opening times: Monday - Friday 9am - 5:30pm

Meaco App

Control your new dehumidifier with the Meaco app.

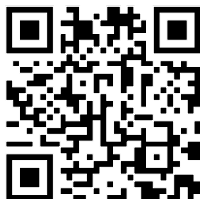

Scan the QR code to install the Meaco app or download the Meaco app from the App store or Google Play.

Open the app and follow the instructions to create a new account and pair your dehumidifier.

Connecting your dehumidifier to your Meaco app

1. Plug the dehumidifier into the mains and press the power button.
2. Hold the Smart Laundry button down for 2 seconds.
3. The WiFi indicator (under the Smart Laundry button) will light up on the chase display.
4. In the Meaco app, press the + button in the top right hand corner and then 'Add device'.
5. The app will search for nearby devices and your dehumidifier will appear, click 'Add'.

What's included

Carefully unpack the dehumidifier. Keep all packaging materials away from children. We recommend flat packing and keeping hold of the box should you need it in the future.

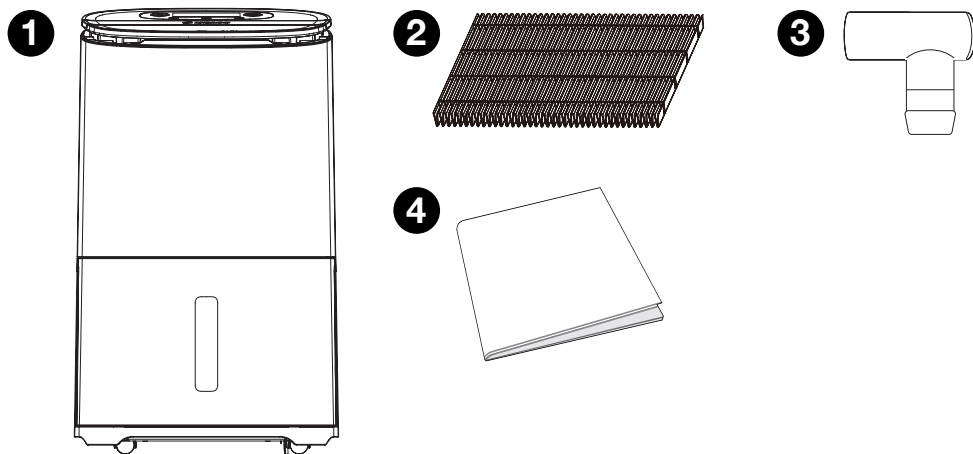

1. MeacoDry Arete® Two Dehumidifier and Air Purifier
2. Free H13 HEPA Filter
3. Hose adaptor
4. Instruction manual

Product identification

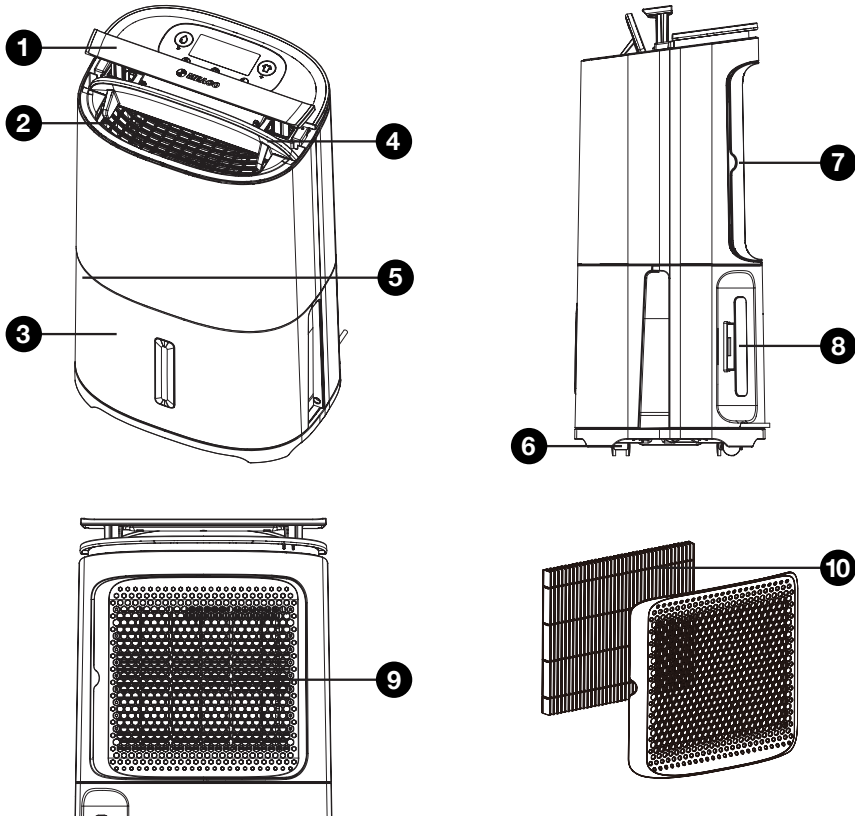

- 1. Handle
- 2. Air outlet
- 3. Water tank
- 4. Louvre
- 5. Hose adaptor
- 6. Castors
- 7. Combined dust filter and case
- 8. Cable tidy
- 9. Air inlet
- 10. H13 HEPA filter

Important! Remove the plastic bag around the H13 HEPA filter before use.

To lift the handle use two hands: one on the left-hand side and one of the right-hand side, then lift.

The hose adaptor (found inside the lid of the water tank) can be connected to a standard garden hose for continuous drainage.

First steps

When you first receive your dehumidifier, it is important you follow the steps below carefully:

1. Check your dehumidifier and its box and packaging for any transport damage. In case of damage, inform the sender immediately.
 2. Leave the dehumidifier to stand for six hours before turning it on. This will allow any refrigerant that may have moved during transit to settle.
 3. Choose where you would like to locate your dehumidifier. This dehumidifier has been carefully designed allowing you to place the dehumidifier as close to a wall as you wish.
 4. Remove the plastic bag around the H13 HEPA filter and insert it in the back of your dehumidifier. This will enable air purification as well as dehumidification. For further instructions, see page 17.
 5. Plug the dehumidifier into the mains and turn it on using the Power Button. Allow the dehumidifier to gauge an accurate reading of the humidity level in the environment it is situated in for the first 10 minutes.
 6. Open the louvre to allow air to move freely.
 7. Use page 10 to determine the correct setting for your dehumidifier usage.
-

Dehumidifying your house

Your dehumidifier can be used to maintain an optimum humidity level throughout your house or flat. Moisture in the air from the entire house/flat will migrate towards the dehumidifier, reducing the humidity level. When doing so, we would recommend the following:

- Situate your dehumidifier in a central area (e.g. a landing or hallway)
- Keep your dehumidifier running 24/7
- Keep all internal doors open
- Keep external doors and windows closed
- Use Smart Humidity Mode to set your dehumidifier to reach a target of 55%RH
- Open the louvre
- Insert the H13 HEPA filter to enable air purification

If you want to use your dehumidifier to reduce the humidity level in a particular room or problem area, use the same settings as above, but instead keep the doors and windows closed.

Using your dehumidifier to dry your laundry

Dehumidifiers are very efficient at drying your laundry quickly and cheaply. When doing so, we would recommend the following:

- Situate your dehumidifier in a room with your laundry
 - Place the dehumidifier close to your laundry but not too close that water could drip onto the dehumidifier
 - Keep all doors and windows closed
 - Use Smart Laundry Mode to set your dehumidifier to run continuously for 6 hours
 - Open the louvre and direct the airflow towards your laundry
 - Use an air circulator to circulate the dry air and reduce drying time
-

Display readings

When the dehumidifier is turned on the chase display will show the current humidity level and the target humidity level. The current humidity level is shown by the bars below the line. The target humidity level is the figure circled above the line.

Operation

When the dehumidifier is first plugged into the mains it will beep once, the power and timer button will light up.

- All buttons on the control panel only require a short press: press the buttons firmly and quickly.
- When in use the louvre must be open - this can be done manually.

Control panel

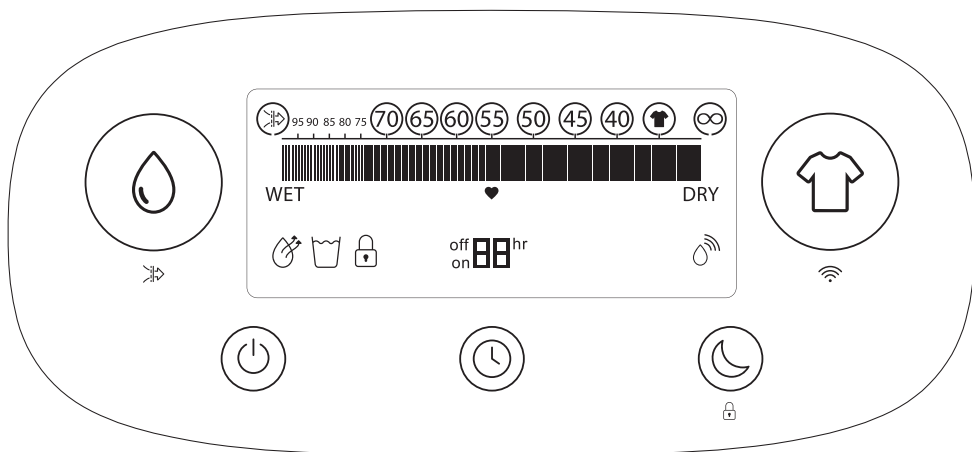

 **ON/OFF:** Press the power button once to turn the dehumidifier on. The display will turn on and the dehumidifier will start to run. To turn the dehumidifier off press the power button again.

 **Smart Humidity Mode:** Press this button and the dehumidifier will default to a target humidity of 55%RH.

 **Variable Humidistat:** To set your dehumidifier to reach a target humidity other than 55% continue to press the Smart Humidity Mode button and scroll through the options in the following order: 70, 65, 60, 55, 50, 45, 40, ∞. Once you have reached your desired target, it will stay displayed with a circle around it.

 **Continuous:** With this target the dehumidifier will continue to run and only turn off when the water tank is full, regardless of the humidity level.

Once the target humidity level has been reached (-3%) the dehumidifier will stop. Every 30 minutes the fan will run and check the humidity level, the dehumidifying indicator will turn off.

If the humidity level has increased more than 3% above the target, the compressor will turn on and the dehumidifier will start to run again – the dehumidifying indicator will be solid. If the humidity level is within 3% of the target, the dehumidifier will go back to sleep and check the humidity level in another 30 minutes.

If the current humidity level is within 15% of the target humidity level, the dehumidifier will default to low fan speed. If the current humidity level is 15% or more above the target humidity level the dehumidifier will default to medium fan speed.



Air Purification Mode: Hold the smart humidity button down for 2 seconds to enter Air Purification Mode  – the air purifier indicator will show on the display in the top left corner. In Air Purification Mode the dehumidifier will not dehumidify, it will simply purify the air. This mode is useful during the months when dehumidification is not required. To remove Air Purification Mode, hold the smart humidity button down for 2 seconds – this will take you back to Smart Humidity Mode.

Important! If a H13 HEPA filter is installed, the dehumidifier will always be purifying the air – it does not specifically need to be in Air Purification Mode.



Smart Laundry Mode: Press the Smart Laundry Mode button once to enter Smart Laundry Mode. In this mode, the dehumidifier will default to a target humidity of 35%RH and high fan speed. The laundry indicator will show on the display. The dehumidifier will run in Smart Laundry Mode for 6 hours, after 6 hours the dehumidifier will turn off. To adjust the amount of time left in Smart Laundry Mode, press the timer button. To stop Smart Laundry Mode press the Smart Humidity button or turn the dehumidifier off and on again.

If the dehumidifier reaches a humidity level of 32%RH before the 6 hours is up, the compressor will turn off to stop the air from becoming too dry, but the fan will continue to run. The dehumidifying indicator will turn off. If the relative humidity increases to 38%RH the compressor will turn back on. It will do this until the 6-hour timer is up.

Hold the smart laundry button for 2 seconds to enter WiFi mode . For further instructions see page 6.



Timer: Use the timer button to set an ON or OFF timer. To remove either the ON or OFF timer, press the timer button until you reach '00 hrs'.

Timer On: When the dehumidifier is in standby mode, use the timer button to move between 1 and 24 hours in which the dehumidifier will turn on. The interface will display the number of hours in which the dehumidifier will turn on e.g. 'on 03 hr'. Please leave a one second pause for the timer to be set.

Timer Off: When the dehumidifier is on, use the timer button to move between 1 and 24 hours in which the dehumidifier will turn off. The interface will display the number of hours in which the dehumidifier will turn off e.g. '03 hr' and 'OFF'. If in Night Mode, the interface will turn off. Please leave a one second pause for the timer to be set.



Night Mode: Press the Night Mode / child lock button once to enter Night Mode. The fan speed will be reduced to low (only if it is currently in high); the buttons will not beep when pressed and all lights on the display will turn off (the Night Mode indicator will turn off 3 seconds later than the rest of the display). Press any button to wake up the dehumidifier and view the display. Press the Night Mode / child lock button twice to exit Night Mode.



Child Lock: Hold the Night Mode / child lock button down for 2 seconds to lock the dehumidifiers control panel – once locked you will not be able to change any settings or turn the dehumidifier off. The dehumidifier will beep once, and the child lock indicator will light up. To remove child lock, hold the Night Mode / child lock button down for another 2 seconds.



Dehumidifying Indicator: The dehumidifying indicator will light up on the chase display when the compressor is running, and the dehumidifier is dehumidifying. The indicator will turn off when the dehumidifier is checking the humidity level and when the dehumidifier is defrosting - this is normal.



Water Tank Full Indicator: Once the water tank is full, the dehumidifier will continue to run in fan only mode for 3 minutes to blow any excess water off the coils and ensure that when you remove the tank there is no water left that could drip out of the spout. The water tank full indicator will light up on the chase display and beep five times (except in Night Mode). The dehumidifier will stop running until the water tank has been emptied and inserted back in place. Once the water tank has been emptied and inserted back in place, the dehumidifier will continue to run in the previous mode.



Air Purification Indicator: The air purification indicator will light up on the chase display when the dehumidifier is in air purification (AP) mode only.



Child Lock Indicator: The child lock indicator will light up on the chase display when child lock has been enabled.



Heart Indicator: The heart indicator recommends the suitable target humidity level - 55%RH.

WET

WET Indicator: When the dehumidifier is switched off and plugged in (in Standby mode), the WET indicator will light up if the relative humidity measures above 70%. This indicates that the current humidity is very high and the dehumidifier should be turned on.

The WET and DRY indicators will always be lit up on the display when the dehumidifier is switched on to show which end of the %RH scale is which.

Water tank

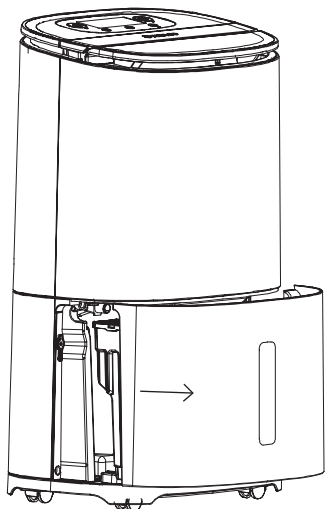

The dehumidifier can be used to collect water in one of two ways: via the water tank or via continuous drainage. For more information on how to use continuous drainage, see page 15.

When the water tank is full and requires emptying, the dehumidifier will turn off, beep five times (except in Night Mode) and the water tank full indicator will light up on the chase display. To empty the water tank, simply place your hands in the recesses on both sides, hold onto the tank and pull horizontally towards you. Use the pouring holes on the left or right corner of the tank to empty the water (the water tank does not need to be removed).

The water collected can be used to water non-edible plants only – do not consume.

Water tank float

Located inside the water tank is a float. It is essential that the float is NOT removed from the water tank. The float measures the level of water in the water tank and triggers the sensor to turn the dehumidifier off when the water tank is full. If the float is removed from the water tank, the dehumidifier will not run.

Continuous drainage

Continuous drainage can be used to drain water from the dehumidifier without having to empty the water tank. This is ideal for customers who wish to leave their dehumidifier unattended in garages or second homes.

The right-angle adaptor required can be found in the lid of the water tank. This adaptor has been designed to fit a standard garden hose (ID: 12.5mm). Hose not included. Make sure the hose runs downwards with no kinks, bends or blockages to allow the water to drain out via gravity.

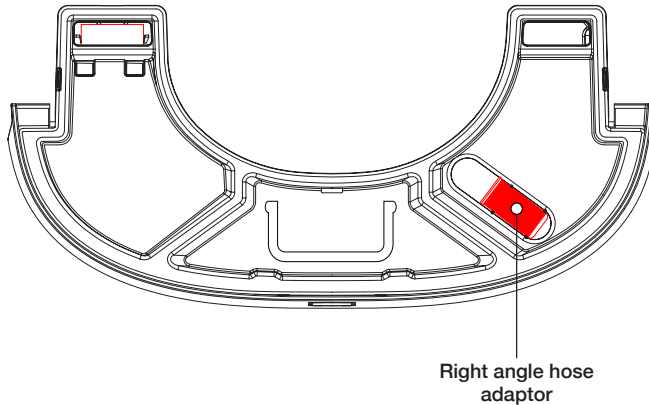

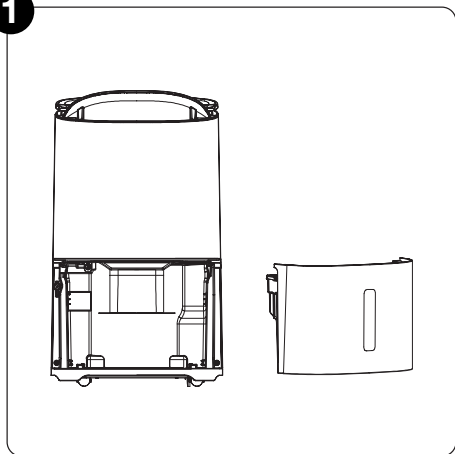
1

Remove the water tank

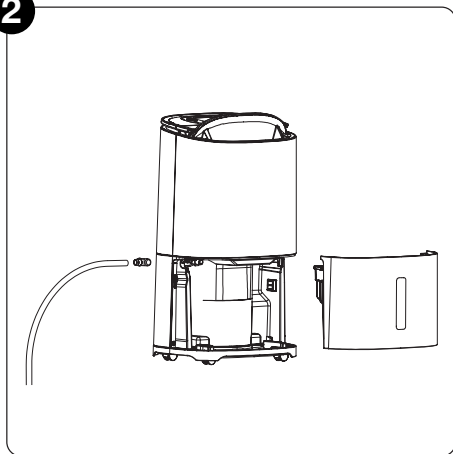
2

Remove the right-angle adaptor from the water tank lid and push it onto the spout. The spout is where water drips out of the dehumidifier and is located on the left-hand side.

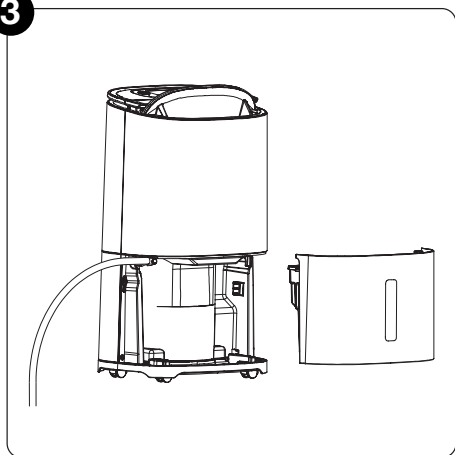
3

Attach the hose to the spout.

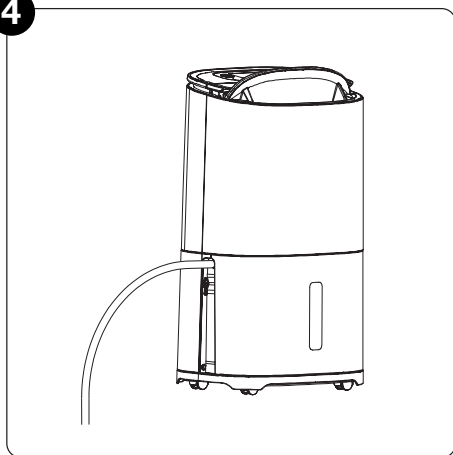
4

Insert the water tank back into the dehumidifier.

Maintenance

To ensure your dehumidifier is always performing at its best, it's important to regularly clean it.

- Always unplug your dehumidifier from the mains before cleaning.
 - Do not allow the dehumidifier to get wet.
-

Cleaning the exterior

Clean the exterior with a soft, dry cloth. If the dehumidifier is extremely dirty, use a slightly damp cloth. Never spray the device with water.

Cleaning the dust filter

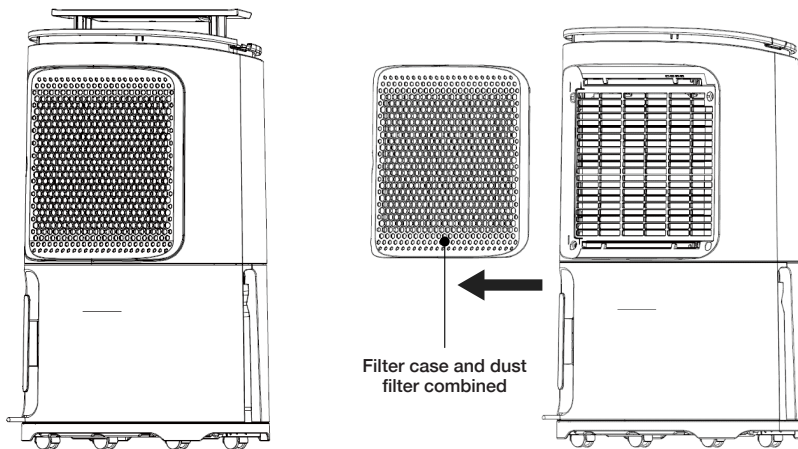

The dust filter is a life-long filter and therefore should not need to be replaced (other than for wear and tear reasons). When used regularly, the filter may become clogged with dust and dirt particles. The filter must be cleaned a minimum of every two weeks (not doing so could invalidate the unit's warranty). Please follow the steps below.

1. Remove the dust filter from the dehumidifier by sliding the filter case to the left, away from the dehumidifier. The dust filter is built into the filter case and cannot be removed – you may have to remove the H13 HEPA filter to access the dust filter.
2. Clean the dust filter with the end of a Hoover or soapy water no hotter than 40°C. Rinse and dry completely before inserting back into the dehumidifier.

Replacing the H13 HEPA filter

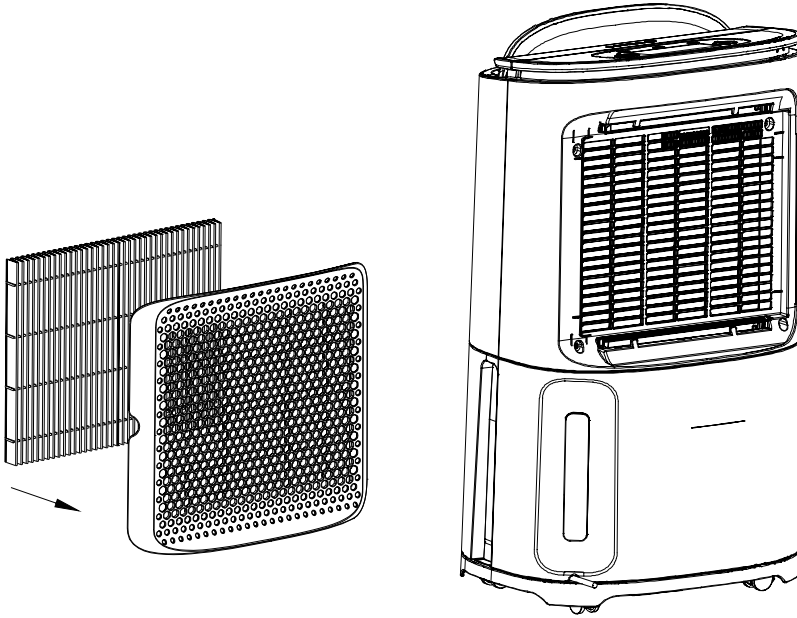

The dehumidifier comes with a free H13 HEPA filter. This H13 HEPA filter can be inserted into the dehumidifier to enable air purification, however this is optional - the dehumidifier can be used without the H13 HEPA filter, this means it will dehumidify the air only and not purify it.

Although we do highly recommend using the dehumidifier with a H13 HEPA filter, if you would like a quieter dehumidifier, removing the H13 HEPA filter will reduce the noise level by 4-5 decibels.

- The H13 HEPA filter is not life-long and must be replaced when the colour changes from white to grey (it depends on the environment the dehumidifier is being used in but the H13 HEPA filter will need replacing roughly every 3 months).
- The H13 HEPA filter can be hoovered every so often to remove any dust or dirt.
- To insert/replace the H13 HEPA filter, place it inside the combined filter case and dust filter, then slide the combined filter case and dust filter into the dehumidifier.
- Replacement H13 HEPA filters can be purchased from meaco.com.

Cleaning the water tank

To clean inside the water tank, simply remove the water tank lid.

Storing

If the dehumidifier will not be used for a long period of time, take the following steps:

1. Run the dehumidifier in Air Purification Mode for a few hours to dry the internals as much as possible. This will help to minimise the chance of mould growing inside the dehumidifier during long term storage.
2. Remove the plug from the socket and empty the water tank. Allow the water tank and the dehumidifier to dry completely, this can take a couple of days.
3. Use the cable tidy on the back of the dehumidifier to wrap the cable away.
4. Clean the filter and store the device in a dust-free location away from direct sunlight, preferably covered with a sheet of plastic.

Troubleshooting

If you come across a problem with your dehumidifier, check the table below and try the suggestions. If the problem persists, contact Meaco.

Error	Action
Dehumidifier indicator is not displayed	The dehumidifier is checking the humidity level to see if it has risen above the set target.
Buttons do not beep when pressed	The dehumidifier is in Night Mode. To remove Night Mode press the Night Mode button twice.
There are no lights on the display	The dehumidifier is in Night Mode. To remove Night Mode press the Night Mode button twice.
The dehumidifier does not dehumidify / collects little water	<ul style="list-style-type: none">• The temperature is either too cold or too warm, make sure the dehumidifier is being used in an environment between 5°C and 35°C.• The humidity level is already very low – below 45%RH the dehumidifier will not collect much water as there isn't enough moisture in the environment.• The target humidity level is higher than the actual humidity level. Use the Smart Humidity Mode button to reduce the target humidity level.• Clean the dust filter and/or replace the H13 HEPA filter. If these are dirty they will block the airflow and prevent the dehumidifier from dehumidifying.• The dehumidifier is in Air Purification Mode. See page 12 for more information.

The dehumidifier works but reduces the humidity level insufficiently/there is little water in the water tank

- Be patient, it takes a few weeks to initially dry a space when a dehumidifier is introduced for the first time.
- The application is too large. This dehumidifier can be used to dry up to a 3-bedroom house.
- Make sure all windows and external doors are shut to reduce the ventilation.
- Clean the dust filter and/or replace the H13 HEPA filter. If these are dirty they will block the airflow and prevent the dehumidifier from dehumidifying.

The windows were clear and now the condensation has returned

This is likely to be because the outside temperature has dropped, and the windows are now colder. Use the dehumidifier on a lower target setting and run it 24 hours a day.

The condensation on my windows will not go, even when the dehumidifier is in CO mode

The surface temperature of the windows is too low for a dehumidifier to prevent condensation. This is common with single glazed windows and when the air temperature outside drops below freezing. When the temperature outside increases, running the dehumidifier in CO mode 24 hours a day should clear your windows of condensation.

The dehumidifier is blowing out warm air

The dried air is passed over heating coils before it is blown into the room as part of the dehumidification process. This is normal.

The dehumidifier is blowing out cool air

The dehumidifier does not cool the air, the air may feel cooler because it is moving in the same way as the air from a fan in the summer feels cooler. This is normal.

The dehumidifier is noisy

Clean the dust filter and/or replace the H13 HEPA filter. Make sure the dehumidifier is placed on a flat surface. A dehumidifier will be noisier on wooden floors than carpet.

Night Mode is on but the fan speed hasn't changed

The change in fan speed is subtle. To hear the change: 1) Set the dehumidifier to Smart Laundry Mode 2) Wait a couple of minutes, you will hear the dehumidifier on high fan speed 3) Change the dehumidifier to Night Mode, you will hear the change to low fan speed.

Dirt on carpet

If you are using the dehumidifier on a carpet made from man-made materials it is not unusual for the static within the carpet to attract dust to the area and for there to be some black marks. This is normal for all dehumidifiers from all manufacturers and can be cleaned using standard carpet cleaner.

E1 Please contact Meaco.

E2 Please contact Meaco.

L2 Please contact Meaco.

L3 The environment the dehumidifier is being used in is too warm. Make sure the dehumidifier is being used in 40°C or less.

L4 The environment the dehumidifier is being used in is too cold. Make sure the dehumidifier is being used in 5°C or more.

Meaco customer care

If you have a question about your Meaco dehumidifier, contact our Customer Service team who will be happy to help. Make sure you have your serial number and details of where and when you purchased your dehumidifier.

Contact details

Website: www.meaco.com/pages/contact-us

Email: customerservice@meaco.com

Phone: 01483 234900

Address: Meaco House, Parklands, Railton Road, Guildford, Surrey GU2 9JX, United Kingdom

Specifications

18L	
Dimensions (HWD)	618 x 366 x 272 mm
Nett Weight	15.1 kg
Extraction rate <i>27°C and 60%RH</i> <i>30°C and 80%RH</i>	12 L per day 18 L per day
Noise level <i>Low fan speed</i> <i>Medium fan speed</i> <i>High fan speed</i>	38 dB 40 dB 50 dB
Power consumption	230 watts
Air flow <i>Low fan speed</i> <i>Medium fan speed</i> <i>High fan speed</i>	150 m ³ per hour 175 m ³ per hour 255 m ³ per hour
Auto-restart	Yes
Power supply	220 - 240 V, 50 Hz
Operating temperatures	+5°C to + 35°C
Refrigerant	R290 / 65 g
Water tank size	4.8L

Warranty terms and conditions

There is a five-year manufacturer's warranty on your dehumidifier from the date of delivery.

Within the five-year warranty, all manufacturing defects will be repaired free of charge (excluding damage to the dehumidifiers filter and water tank which can be subject to wear and tear).

The following applies:

1. Any repair or replacement of your dehumidifier or its components during the warranty period will not result in an extension of the warranty period.
2. Any repair or replacement of your dehumidifier or its components during the warranty period will not result in the warranty period starting again.
3. If your dehumidifier has been opened or tampered with or not genuine components have been fitted by yourself or anyone other than a Meaco engineer, your warranty is invalid.
4. Components subject to normal wear and tear, the combined dust filter and case, H13 HEPA filter and hose adaptor are not covered by the warranty.
5. The warranty is only valid on presentation of the original, unaltered and date-stamped purchase receipt. If you are unable to produce proof of purchase, the warranty on your dehumidifier is invalid.
6. The warranty does not cover damage caused by actions that deviate from those as described in the instruction manual or by neglect.
7. The warranty does not cover faults caused by dirt or by third-party products, for example, a Smart Plug.
8. Using a third-party switching device that turns the dehumidifier on or off via the mains will invalidate the warranty.
9. The warranty does not cover accidental damage.
10. All claims for compensation, including consequential damage, will not be entertained.

For the full list of the warranty terms and conditions please visit: www.meaco.com/warranty-terms

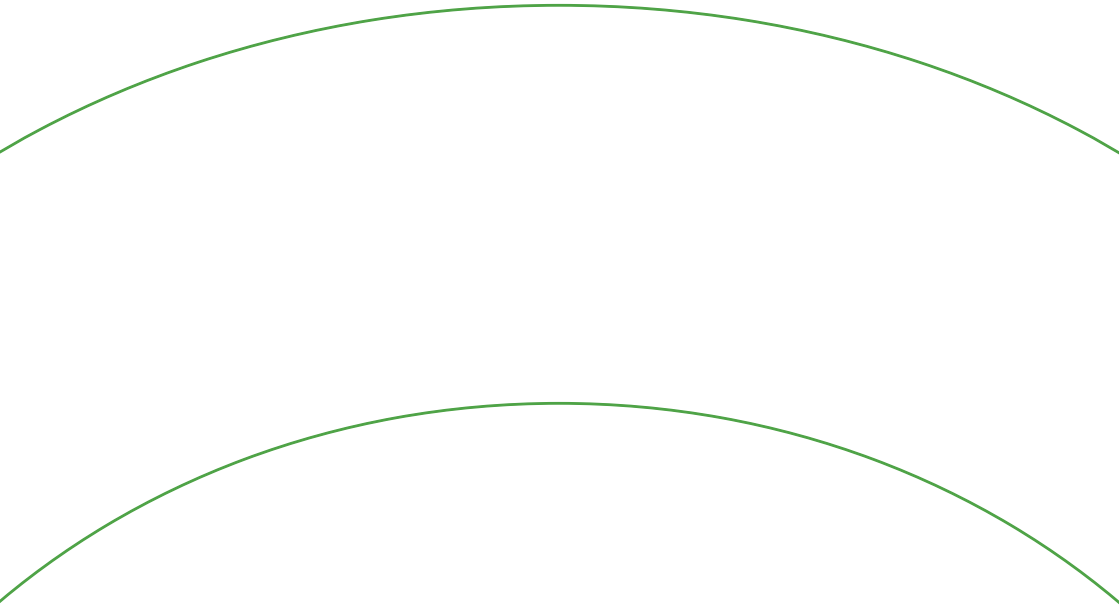

Meaco (U.K.) Limited
Meaco House, Parklands, Railton Road, Surrey GU2 9JX

meaco.com

