



ASSEMBLY INSTRUCTIONS

Pour le français, voir la page 2. Para el español, ver la página 3.

7' x 12' OUTDOOR STORAGE SHED

MODEL 60311

ITM./ART. 274022

BEFORE ASSEMBLY:

- Assemble on a level surface
- 3+ people recommended for setup

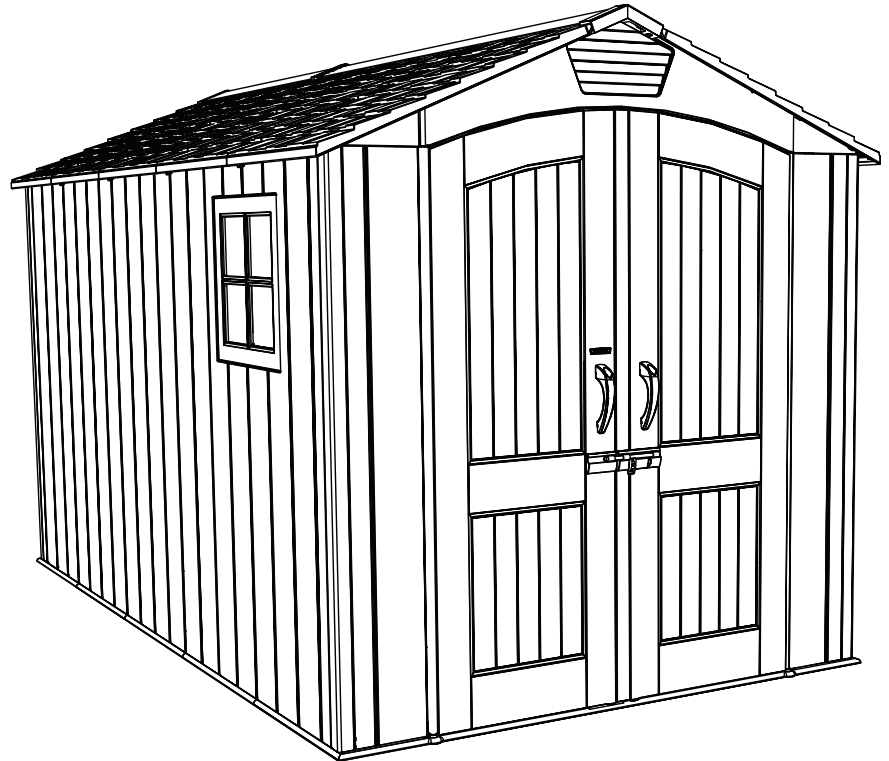

For Customer Service in mainland Europe:
E-mail: cs@lifetimeproducts.eu

FOR DOMESTIC USE ONLY!

IMPORTANT, RETAIN FOR FUTURE REFERENCE: READ CAREFULLY.

TOOLS REQUIRED



TABLE OF CONTENTS

Icon Legend.....	4
Warnings & Notices.....	5
Platform Construction.....	6
Truss Assembly.....	11
Gable Assembly.....	15
Door Assembly.....	18
Floor Assembly.....	29
Wall Assembly.....	33
Window Installation.....	43
Door & Gable Installation.....	46
Parts Identifier.....	51
Roof Assembly.....	56
Door Alignment.....	80
Shed Anchoring.....	83
Latch Installation.....	86
Shelving Installation.....	95
Cleaning & Care.....	98
Registration.....	99
Warranty.....	100

QUESTIONS?

CONTACT LIFETIME CUSTOMER SERVICE:

Call: **1-800-225-3865**
7:00 am–5:00 pm (Monday–Friday) MST
and 9:00 am–1:00 pm Saturday MST

Live Chat: www.lifetime.com
(click on "Ask An Expert" tab)

Video Instructions: www.youtube.com/lifetimeproducts

MODEL# AND PRODUCT ID (you will need both when contacting us)
Model Number: **60311**
Product ID:



INSTRUCTIONS D'ASSEMBLAGE

For English, see page 1. Para el español, ver la página 3.

ABRI DE JARDIN DE 2,1 m x 3,7 m

MODÈLE n° 60311

AVANT L'ASSEMBLAGE :

- Assembler sur une surface de niveau
- Nous recommandons 3+ adultes pour l'assemblage

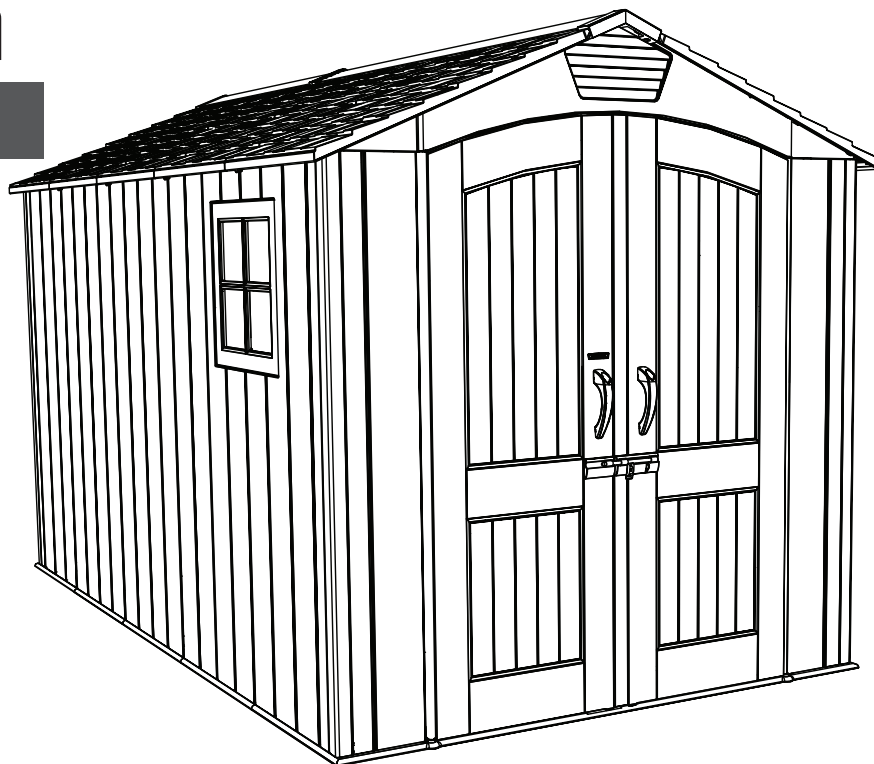

Pour les services à la clientèle du continent européen :

É-mail : cs@lifetimeproducts.eu

POUR L'USAGE DOMESTIQUE SEULEMENT !

IMPORTANT, CONSERVER POUR RÉFÉRENCE : LIRE AVEC PRUDENCE !

OUTILS REQUIS

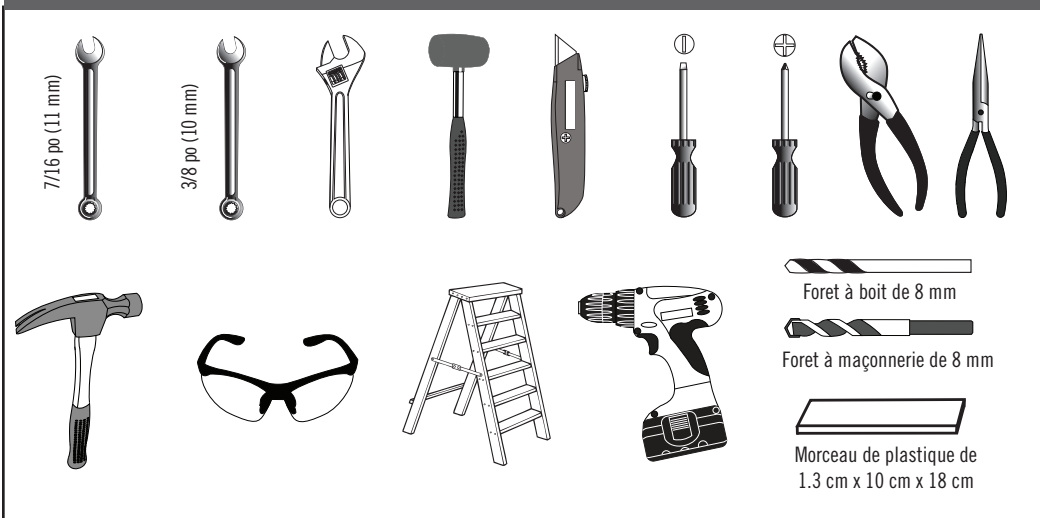

SOMMAIRE

Légende des icônes.....	4
Avertissements et avis.....	5
Assemblage de la plate-forme.....	6
Assemblage des fermes.....	11
Assemblage des pignons.....	15
Assemblage des portes.....	18
Assemblage du plancher.....	29
Assemblage des murs.....	33
Installation des carreaux.....	43
Installation des portes.....	46
Identificateur de pièces.....	51
Assemblage du toit.....	56
Alignement des portes.....	80
L'ancrage de l'abri.....	83
Installation du loquet.....	86
Installation du rayonnage.....	95
Nettoyage et entretien.....	98
Enregistrement.....	99
Garantie.....	101

QUESTIONS ?

CONTACTER AUX SERVICES À LA CLIENTÈLE LIFETIME® :

Composer le **1-800-225-3865**
Du lundi au vendredi 7:00 hr – 17:00 hr (HNR)
et samedi 9:00 hr – 13:00 hr (HNR)

t'Chat en direct: www.lifetime.com
(cliquer sur la languette « Ask An Expert »)
Vidéos éducatifs: www.youtube.com/lifetimeproducts

N° DE MODÈLE ET RÉFÉRENCE DU PRODUIT (il faut avoir les deux en entrant en contact avec nous)
N° de modèle : **60311**
Référence du produit :



INSTRUCCIONES DE ENSAMBLE

For English, see page 1. Pour le français, voir la page 2.

CASETA DE JARDIN DE 2,1 m x 3,7 m

MODELO n° 60311

ITM./ART. 274022

ANTES DEL ENSAMBLE:

- Ensamblar sobre una superficie nivelada
- Recomendamos 3+ adultos para el ensamble

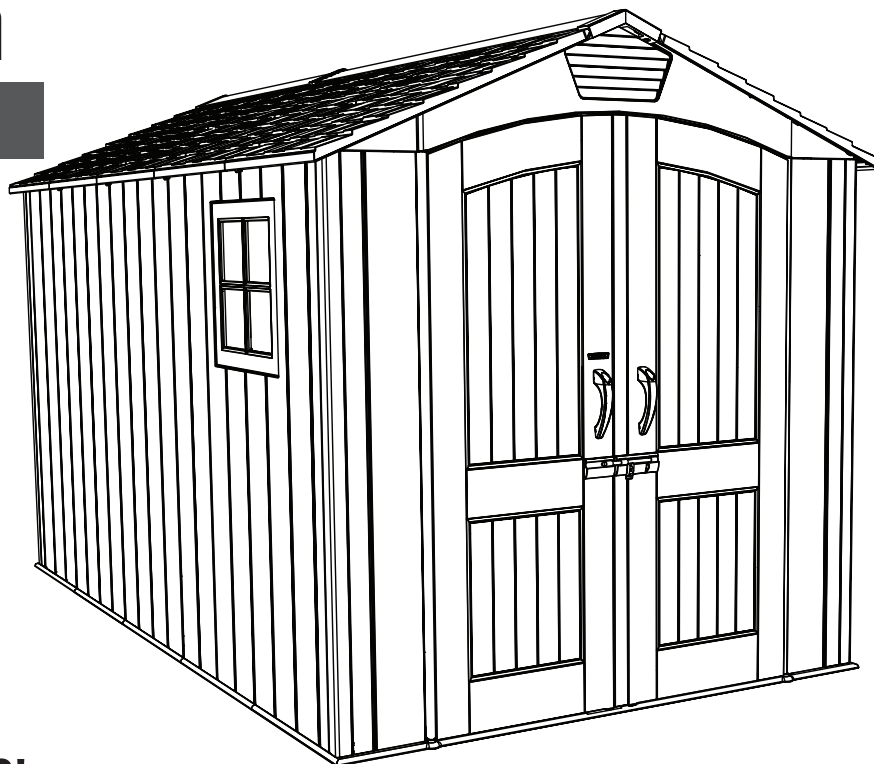

Para el servicio a clientes en el continente europeo:
Correo electrónico: cs@lifetimeproducts.eu

¡SÓLO PARA EL USO DOMÉSTICO!

¡IMPORTANTE, GUARDAR PARA FUTURA REFERENCIA: LEER CUIDADOSAMENTE!

INSTRUMENTAL REQUERIDO

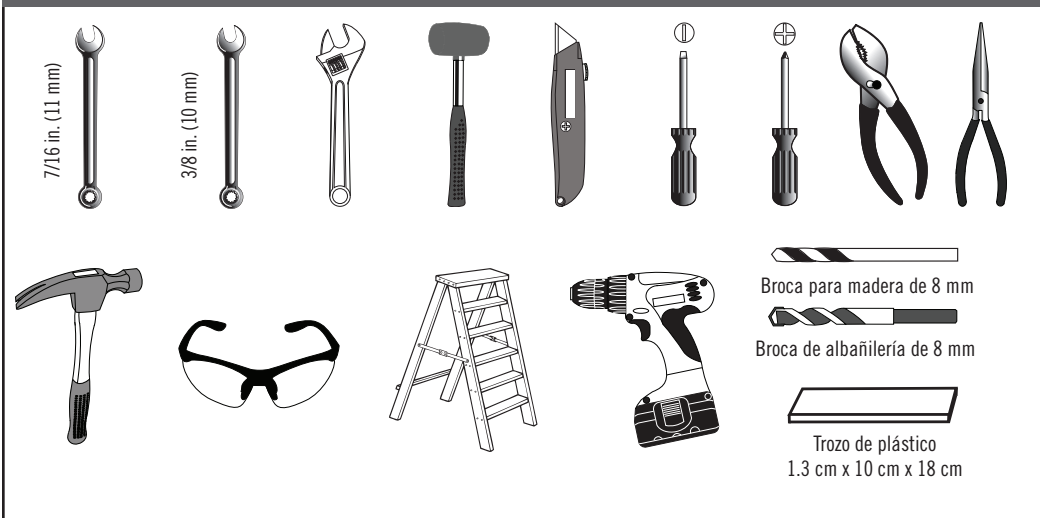

ÍNDICE

Leyenda de íconos.....	4
Advertencias y avisos.....	5
Ensamble de la plataforma.....	6
Ensamble de las cerchas.....	11
Ensamble de las fachadas.....	15
Ensamble de las puertas.....	18
Ensamble del piso.....	29
Ensamble de los muros.....	33
Instalación de las hojas de ventana.....	43
Instalación de las puertas.....	46
Identificador de piezas.....	51
Ensamble del tejado.....	56
Alineación de las puertas.....	80
Anclaje de la caseta.....	83
Instalación del pestillo.....	86
Instalación de la estantería.....	95
Limpieza y cuidado.....	98
Registro.....	99
Garantía.....	102

¿PREGUNTAS?

PONERSE EN CONTACTO CON LOS SERVICIOS DE CLIENTES LIFETIME®:

Marcar : **1-800-225-3865**
De lunes hasta viernes 7:00 hr–17:00 hr (MST)
y sábado 9:00 hr–13:00 hr (MST)

Chat en vivo: www.lifetime.com
(clicar en la lengüeta «Ask An Expert»)
Instrucciones en vídeo: www.youtube.com/lifetimeproducts

MODELO E ID DEL PRODUCTO (se necesitan los dos al contactarnos)
Número de modelo: **60311**
ID del producto:



ICON LEGEND / LÉGENDE DES ICÔNES / LEYENDA DE ÍCONOS



- Indicates special heed should be taken when reading.
- Indique qu'une attention spéciale doit être prise lors de la lecture.
- Indica que uno debe prestar atención al leer.



- Indicates the parts to be used for a section.
- Indique les pièces à utiliser pour une section.
- Indica las piezas que se usarán en una sección.



- Indicates no parts required for a specific section.
- Indique qu'aucune pièce n'est requise pour une section précise.
- Indica que no se necesitan partes en una sección específica.



- Indicates the hardware to be used for a section.
- Indique la quincaillerie à utiliser pour une section.
- Indica el herraje que se usará en una sección.



- Indicates no hardware required for a specific page.
- Indique qu'aucun matériel n'est requis pour une page précise.
- Indica que no se necesita herraje en una página específica.



- Indicates the tools to be used for a section.
- Indique les outils à utiliser pour une section.
- Indica el instrumental que se usará en una sección.



- Indicates to use/not to use an electric drill for a specific step.
- Indique quand utiliser ou ne pas utiliser une perceuse électrique pour une étape précise.
- Indica usar o no usar un taladro eléctrico en un paso específico.



- These Nuts are centerlock nuts. They are designed to be tight; therefore, they will be harder to tighten. Tighten until flush with the metal or plastic.
- Ces écrous sont des écrous de sécurité à blocage central. Ils sont conçus pour être serrés; de ce fait, ils seront plus difficiles à resserrer. Serrer jusqu'à ce qu'ils soient au ras du métal ou plastique.
- Estas tuercas son tuercas de bloqueo central. Ellas son diseñadas para ser apretadas; entonces, ellas serán más difícil ajustar. Apretar hasta que ellas estén al ras del metal o plástico.



WARNINGS & NOTICES / AVERTISSEMENTS ET AVIS / ADVERTENCIAS Y AVISOS

English:

- **Failure to follow these warnings may result in serious injury or property damage and will void warranty.**
- To ensure safety, do not attempt to assemble this product without following the instructions carefully.
- Consult all local building codes to verify if the shed requires a building permit.
- Verify the foundation is completely level before assembling the shed.
- Be aware that plastic pieces can be damaged by overtightening the screws. To avoid damage, we strongly recommend the use of a drill with a low torque setting. A #2 Phillips screwdriver may also be used.
- Three capable adults are required for assembly.
- All who participate in the assembly process should wear safety glasses throughout the assembly.
- If using a ladder during assembly, use extreme caution.
- In heavy snowfall areas, we recommend removing snow from the roof.
- Do not use or store hot objects near the product.
- Proper and complete assembly are essential to reduce the risk of accident or injury.
- We strongly recommend anchoring your shed when it is finished. The last section, Shed Anchoring, in this manual, shows the hardware you will need to complete the anchoring. You can find the hardware at your local hardware store.
- **Most injuries are caused by misuse and/or not following instructions. Use caution when using this product.**

Français :

- **Un manquement de suivre ces avertissements peut entraîner des blessures graves ou des dommages à la propriété et annulera la garantie.**
- Afin d'assurer la sécurité, ne pas tenter d'assembler ce produit sans suivre les instructions avec attention.
- Consulter tous les codes du bâtiment afin de vérifier si l'abri nécessite un permis de bâtiment.
- Vérifier que la fondation soit complètement à niveau avant l'assemblage de l'abri.
- Être conscient que les pièces de plastique peuvent être endommagées en serrant trop les vis. Afin d'éviter les dommages, nous recommandons fortement l'utilisation d'une perceuse à faible couple. Une tournevis cruciforme n° 2 peut aussi être utilisé.
- Trois adultes en bonne condition physique sont nécessaires pour l'assemblage.
- Tout ceux qui participent au processus de l'assemblage doivent porter des lunettes de sécurité tout au long de l'assemblage.
- Si une échelle est utilisée pour l'assemblage, il faut être extrêmement prudent.
- Dans les zones de grandes tombées de neige, nous recommandons d'enlever celle-ci du toit.
- Ne pas utiliser ou entreposer d'objet très chaud près de ce produit.
- Un bon assemblage complet est nécessaire pour réduire le risque d'accident ou de blessure.
- Nous recommandons fortement d'ancrer votre remise lorsque l'assemblage est terminé. La dernière section, Ancrage de la remise, de ce manuel démontre les matériaux nécessaires afin de compléter l'ancrage. Les matériaux se trouvent dans la quincaillerie locale.
- **La majorité des blessures sont causées par une mauvaise utilisation et/ou le non suivi des instructions. Être prudent lorsque vous utilisez ce produit.**

Español:

- **No seguir estas advertencias puede resultar en lesiones graves o daños a la propiedad y anulará la garantía.**
- A fin de garantizar la seguridad, no intentar ensamblar este producto sin seguir cuidadosamente las instrucciones.
- Consultar todos los códigos de construcción locales para verificar si la caseta requiere un permiso de construcción.
- Verificar que el concreto esté nivelado completamente antes de ensamblar la caseta.
- Tener en cuenta que las piezas de plástico pueden dañarse si los tornillos se aprietan de más. A fin de evitar daños, lo exhortamos a que use un taladro con función de torque bajo. También puede usarse un desatornillador Phillips no. 2.
- Se necesitan tres adultos para el ensamble.
- Todos los que participen en el proceso de ensamble debe usar anteojos de seguridad durante todo el ensamble.
- Si se usa una escalera durante el ensamblado, es preciso tener cuidado.
- En áreas de nevadas fuertes, recomendamos retirar la nieve del techo.
- No usar ni guardar objetos calientes cerca del producto.
- El ensamble correcto y completo son esenciales para reducir el riesgo de accidente o lesión.
- Lo exhortamos a anclar la caseta al terminar el ensamble. La última sección, Anclaje de la caseta, en este manual muestra el herraje necesaria para terminar el anclaje. Se encuentra el herraje en la ferretería local.
- **La mayoría de las lesiones suceden a causa del mal uso y/o por no seguir las instrucciones. Tener precaución al usar este producto.**

PLATFORM CONSTRUCTION / CONSTRUCTION DE LA PLATE-FORME / CONSTRUCCIÓN DE LA PLATAFORMA



• You must provide a platform on which to assemble your shed. Proper building permit documentation may be required in your neighborhood. Consult all local building codes prior to assembling the shed. Before beginning assembly, you must pour or construct a platform. There are two types:

- **Concrete**
- **Wood Frame**

Select the type, but know the surface must be leveled and flat before installation. If the surface is not properly leveled and flat, the shed will not assemble correctly. Proper surface leveling will save you time in the long run, so please do not ignore this step. **We recommend a Concrete platform. It will be the most durable and long-lasting choice. The platform you choose must be built above ground in order to avoid water pooling inside the shed. All lumber must be rated for outdoor use!**



• Il faut construire une plate-forme sur laquelle assembler l'abri. Il est possible que votre quartier exige une documentation visant les permis de construire. Consulter tous les codes du bâtiment locaux, ainsi que les décrets des villes et comtés, pour vérifier que la construction de l'abri extérieur n'exige pas un permis de construire. Avant de commencer l'assemblage, il faut couler ou construire une plate-forme. Il y a deux styles :

- **Béton**
- **Cadre à bois**

Sélectionner le style, mais savoir que la surface d'installation doit être de niveau et plate. Si la surface n'est pas correctement de niveau et plate, l'assemblage de l'abri ne se fera pas correctement. On gagnera du temps sur le long terme grâce à une surface bien de niveau, ne négliger donc pas cette étape. **Nous recommandons une plate-forme en béton. Ce choix sera le plus durable. La plate-forme choisie doit être construite au-dessus du sol afin d'éviter l'accumulation d'eau à l'intérieur de l'abri. Tous le bois d'oeuvre doit être approuvé pour l'usage à l'extérieur !**



• Es preciso construir una plataforma sobre la cual ensamblar la caseta. Puede suceder que en su vecindario se requiera la documentación apropiada de un permiso de construcción. Consultar todos los códigos locales de construcción y los reglamentos de la ciudad y el municipio para asegurarse de que la construcción de la caseta no requiere un permiso de construcción. Antes de comenzar el ensamble, es necesario verter o construir una plataforma. Hay dos clases:

- **Concreto**
- **Armazón de madera**

Seleccionar la clase, mas saber que la superficie debe estar nivelada y plana antes de comenzar el ensamble. Si la superficie no está nivelada y plana de manera adecuada, la caseta no podrá ensamblarse correctamente. La nivelación de la superficie le ahorrará tiempo de trabajo, por lo tanto, no ignorar este paso. **Recomendamos una plataforma hecho de concreto. Será la elección más perdurable. La plataforma debe ser construida arriba del suelo para evitar el aflujo de agua dentro de la caseta. ¡Toda la madera debe estar clasificada para uso externo!**

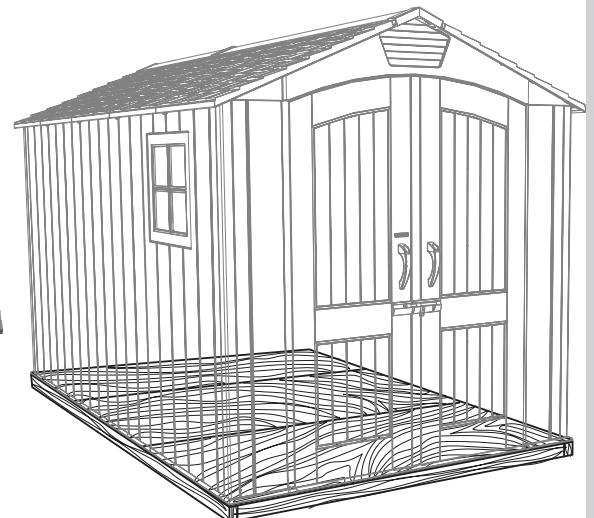
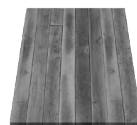
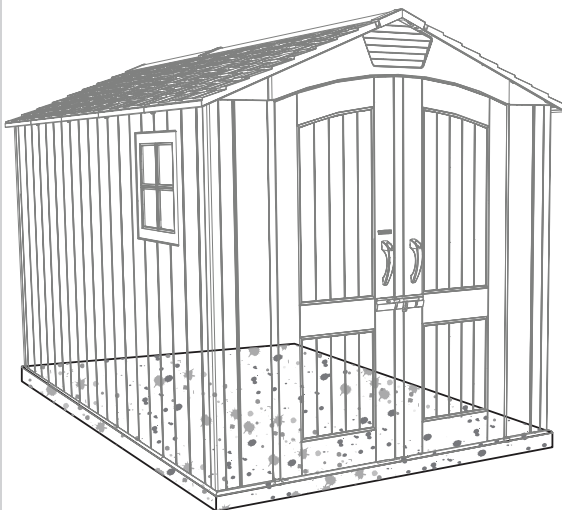

► SECTION 1 (CONTINUED) / SECTION 1 (SUITE) / SECCIÓN 1 (CONTINUACIÓN)

CONCRETE REQUIRED / BÉTON REQUIS / CONCRETO REQUERIDO



1 yd³ (0,77 m³)

1.1

CONCRETE PLATFORM / PLATE-FORME EN BÉTON / PLATAFORMA DE CONCRETO

- **The concrete should be approximately 4" (10 cm) thick.** The actual dimensions of the shed, at its widest and longest points, are 84" x 144" (213 x 366 cm). Ensure you select a site that will accommodate these measurements. **The floor dimensions are a bit smaller than those of the roof; therefore, you will need to build a level surface of 81 1/2" x 137 1/2" (207 x 349 cm).**
- **Le béton doit être un épaisseur de 10 cm (4 po).** Les dimensions réelles de votre abri, aux points les plus large et long, sont 213 x 366 cm (84 x 144 po). Veiller à sélectionner un site qui accommodera ces dimensions. **Les dimensions du plancher de l'abri sont plus petites que le toit; ensuite, il faut créer une surface nivelée de 207 x 349 cm (81 1/2 x 137 1/2 po).**
- **El concreto debe tener, por lo menos, 10 cm (4 in) de espesor.** Las dimensiones reales de la caseta, a los puntos más ancho y largo, son 213 x 366 cm (84 x 144 in). Asegurarse de seleccionar un sitio que acomodará estas medidas. **Las dimensiones del piso de la caseta son más pequeñas que el tejado; entonces, es necesario crear una superficie nivelada de 207 x 349 cm (81 1/2 x 137 1/2 in).**

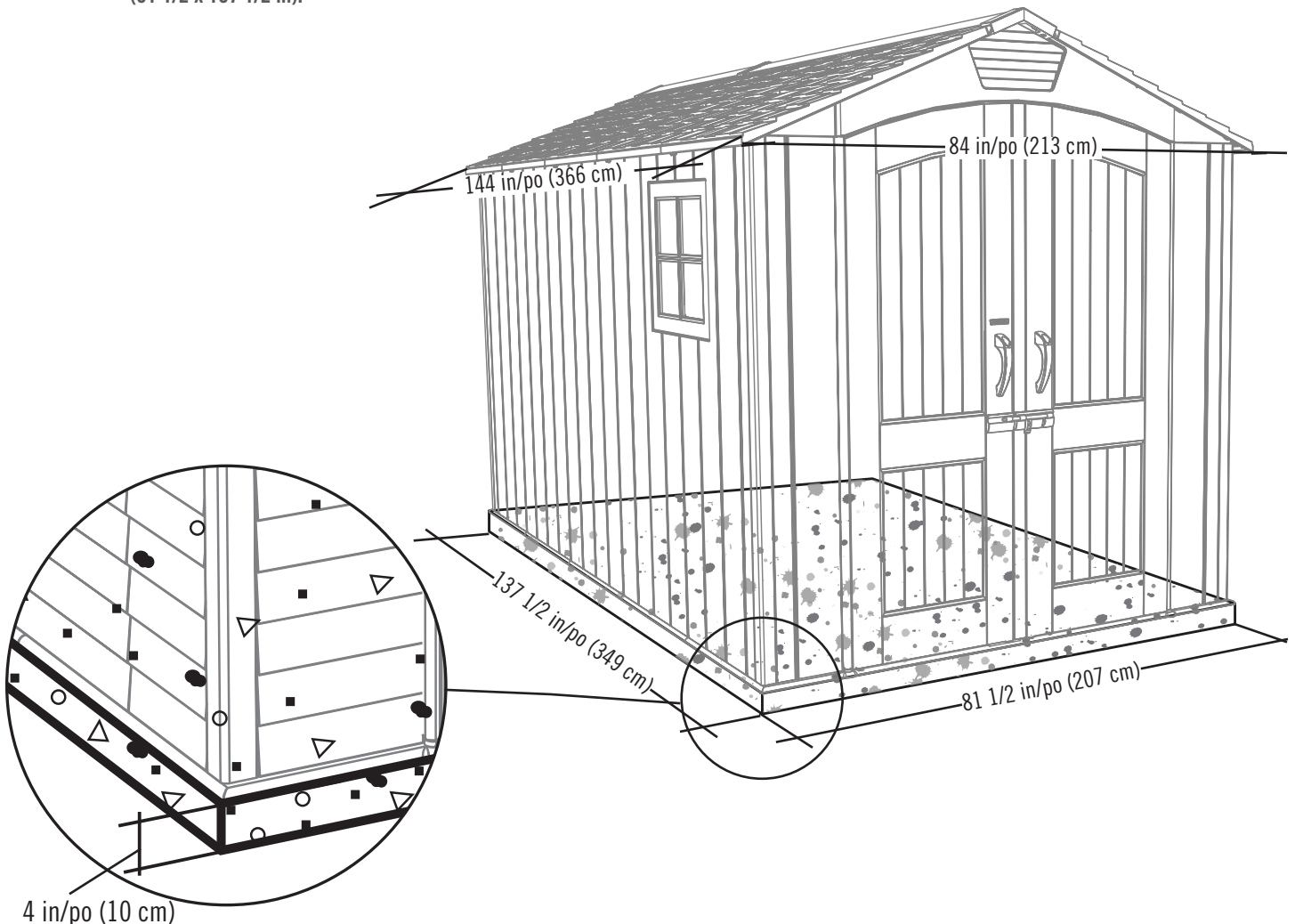

► SECTION 1 (CONTINUED) / SECTION 1 (SUITE) / SECCIÓN 1 (CONTINUACIÓN)

WOOD REQUIRED / BOIS REQUIS / MADERA REQUERIDA



1.2

WOOD PLATFORM / PLATE-FORME EN BOIS / PLATAFORMA DE MADERA

- **All lumber must be rated for outdoor use!** The actual dimensions of the shed, at its widest and longest points, are 84" x 144" (213 x 366 cm). Ensure you select a site that will accommodate these measurements. **The floor dimensions are a bit smaller than those of the roof; therefore, you will need to build a level surface of 81 1/2" x 137 1/2" (207 x 349 cm).**
- **Tous le bois d'oeuvre doit être approuvé pour l'usage à l'extérieur !** Les dimensions réelles de votre abri, aux points les plus large et long, sont 213 x 366 cm (84 x 144 po). Veiller à sélectionner un site qui accommodera ces dimensions. **Les dimensions du plancher de l'abri sont plus petites que le toit; ensuite, il faut créer une surface nivelée de 207 x 349 cm (81 1/2 x 137 1/2 po).**
- **¡Toda la madera debe estar clasificada para uso externo!** Las dimensiones reales de la caseta, a los puntos más ancho y largo, son 213 x 366 cm (84 x 144 in). Asegurarse de seleccionar un sitio que acomodará estas medidas. **Las dimensiones del piso de la caseta son más pequeñas que el tejado; entonces, es necesario crear una superficie nivelada de 207 x 349 cm (81 1/2 x 137 1/2 in).**

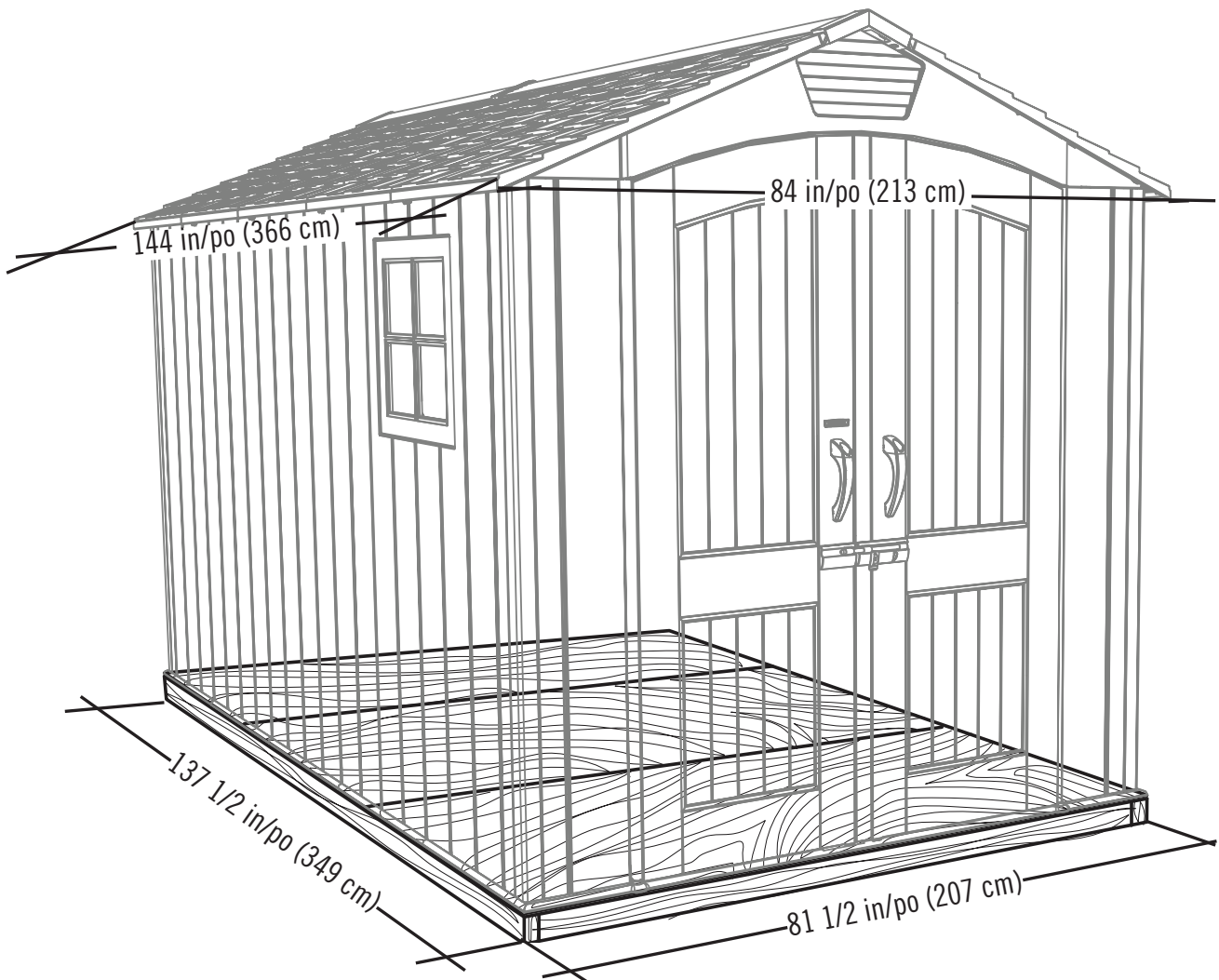

► SECTION 1 (CONTINUED) / SECTION 1 (SUITE) / SECCIÓN 1 (CONTINUACIÓN)

TOOLS, PARTS, AND HARDWARE REQUIRED / OUTILS, PIÈCES, ET QUINCAILLERIE REQUIS / INSTRUMENTAL, PIEZAS, Y HERRAJE REQUERIDOS

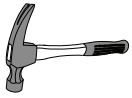

2 in/po x 4 in/po x 78 1/2 in/po (5 x 10 x 199 cm) (x10)



2 in/po x 4 in/po x 137 1/2 in/po (5 x 10 x 349 cm) (x2)

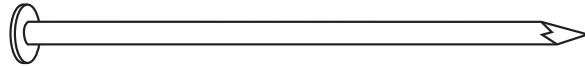

16d 3 in/po (16d x 7,62 cm) (x40)

1.2.1

WOOD PLATFORM / PLATE-FORME EN BOIS / PLATAFORMA DE MADERA

- **Ensure all lumber is treated and approved for outdoor use.** Build frame to 81 1/2" x 137 1/2" (207 x 349 cm) (**outside dimensions**). You can also use the plywood as a flat surface when building this frame.
- **Veiller à ce que le bois d'œuvre à été traité et approuvé pour l'usage à l'extérieur.** Construire un cadre de 207 x 349 cm (81 1/2 po x 137 1/2 po) (**dimensions extérieures**). Si besoin, utiliser le contreplaqué comme une surface plate pendant l'assemblage de ce cadre.
- Asegurarse de usar madera tratada y aprobada para el uso externo. Construir el armazón a 207 x 349 cm (81 1/2 x 137 1/2 in) (**dimensiones exteriores**). Se puede también usar el contrachapado como una superficie plana al ensamblar este armazón.

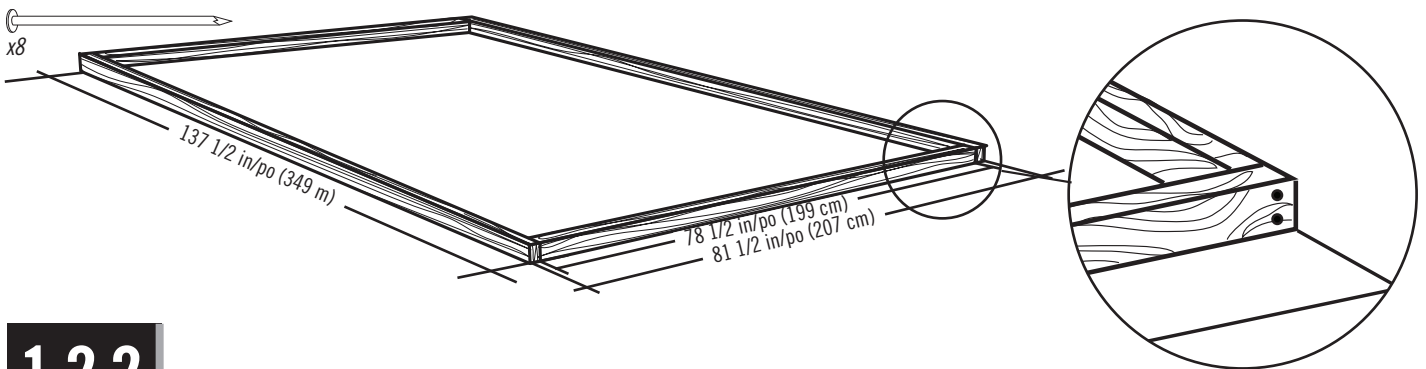

1.2.2

- To ensure studs are in the correct location for nailing plywood in the next step, start measuring from the corner 16" (40,1 cm), and then measure from center to center.
- Pour être sûr d'avoir assez de montants pour clouer le contreplaqué dans la prochaine étape, commencer à mesurer à partir de cette montant 40,1 cm (16 po) vers le centre du deuxième montant. Ensuite, mesurer de centre à centre pour les montants restants.
- Para asegurarse que los montantes están en las ubicaciones correctas para el contrachapado en el paso siguiente, comenzar a medir desde el borde del montante hasta el centro del próximo montante 40,1 cm (16 in). Luego, tomar la medida de centro a centro en los montantes restantes.

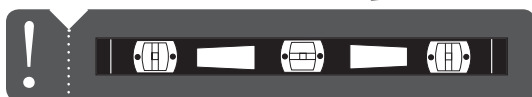
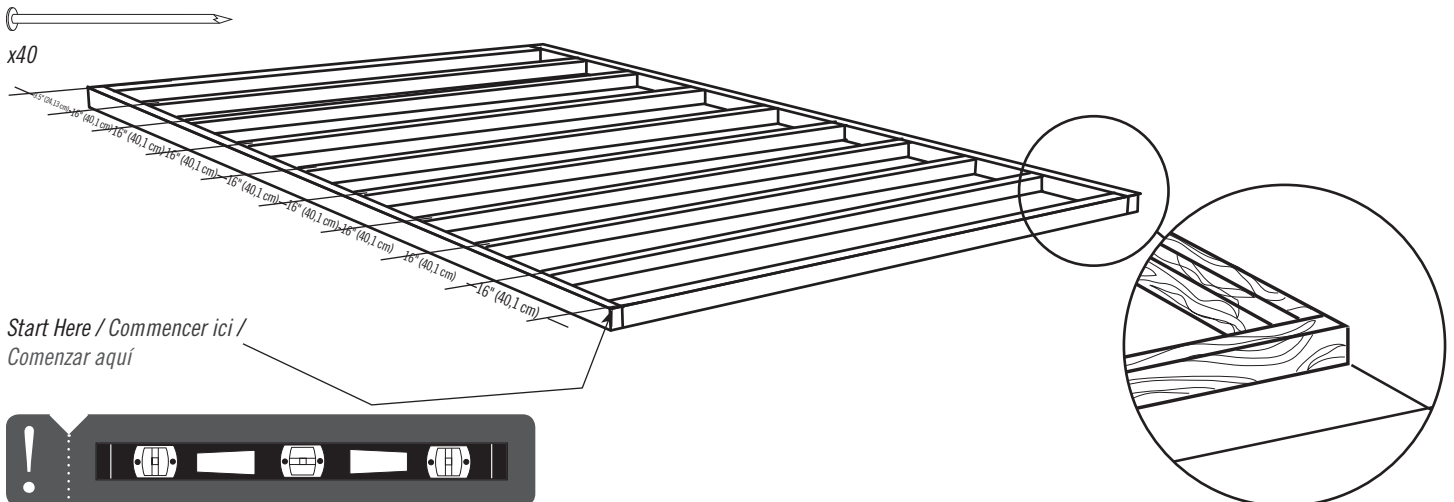

► SECTION 1 (CONTINUED) / SECTION 1 (SUITE) / SECCIÓN 1 (CONTINUACIÓN)

TOOLS, PARTS, AND HARDWARE REQUIRED / OUTILS, PIÈCES, ET QUINCAILLERIE REQUIS / INSTRUMENTAL, PIEZAS, Y HERRAJE REQUERIDOS

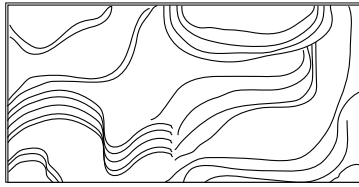
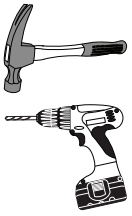

48 in/po x 81 1/2 in/po x 3/4 in/po
(122 x 212 cm x 19 mm) (x2)

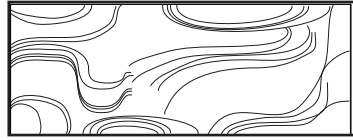

41 1/2 in/po x 81 1/2 in/po x 3/4 in/po
(105 x 207 cm x 19 mm) (x1)

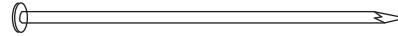

8d 1 1/2 in/po (8d 3,81 cm) (x32)

1.2.3

- Square the frame, measuring from corner to corner. **Measurement A & B should be about the same length.**
- Carrer le cadre en mesurant d'angle à angle. **La mesure « A » et « B » doivent être à peu près la même longueur.**
- Cuadrar el armazón mediendo de esquina a esquina. **La medida «A» y «B» deben ser aproximadamente el mismo largo.**

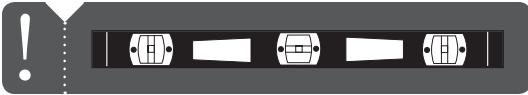
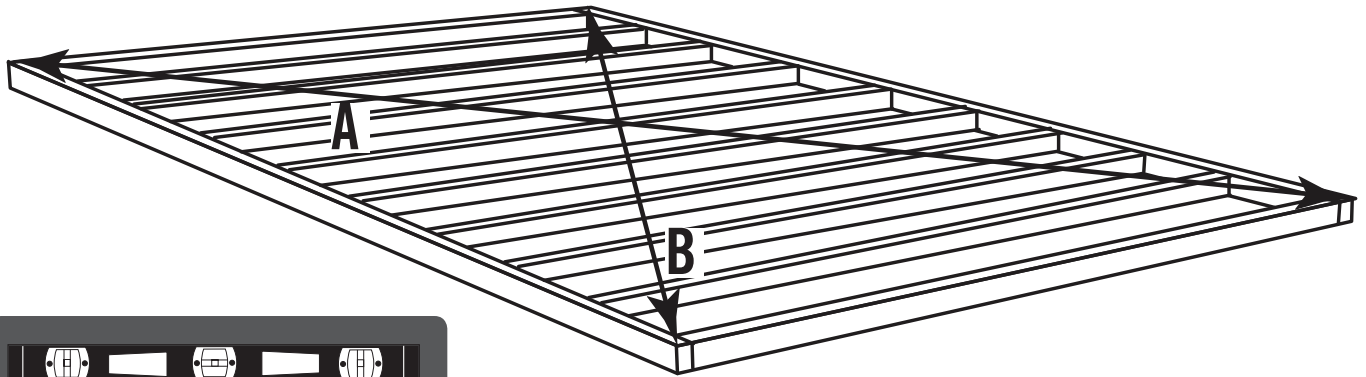

1.2.4

- Using nails, fasten the plywood to the frame. Then, drill 5/16" (8 mm) holes between the studs for drainage.
- En utilisant des clous, attacher bien le contreplaqué au cadre. Ensuite, percer des trous de 8 mm entre les montantes pour le drainage.
- Usando unos clavos, sujetar el contrachapado al armazón. Entonces, taladrar agujeros de 8 mm entre los montantes para el drenaje.

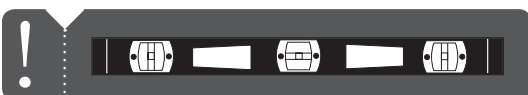
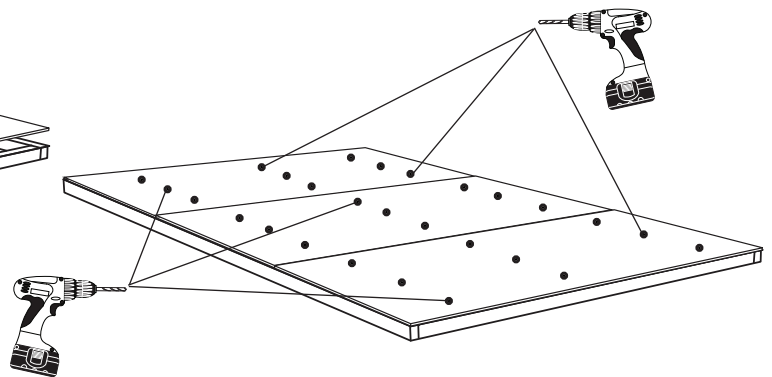
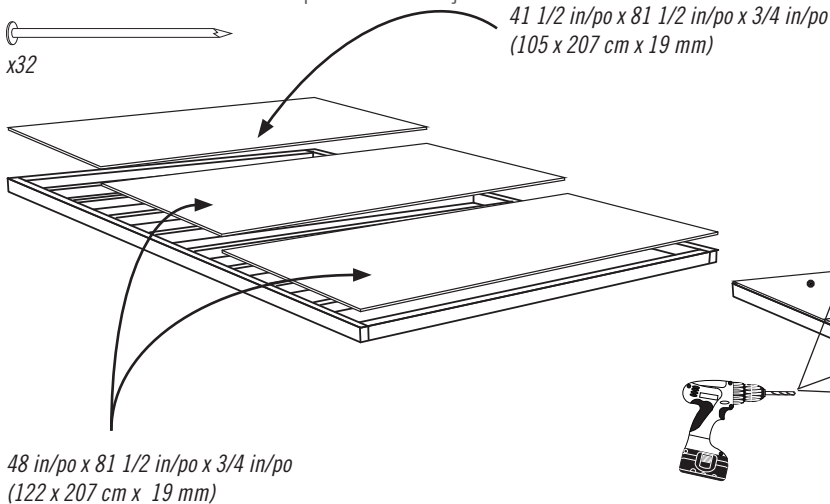

- 5/16" (8 mm) Drainage Holes
- Trous de drainage de 8 mm
- Agujeros para canalización de 8 mm

x27!

2

TRUSS ASSEMBLY / ASSEMBLAGE DES FERMES / ENSAMBLE DE LAS CERCHAS



HARDWARE REQUIRED / QUINCAILLERIE REQUISE / HERRAJE REQUERIDO

Hardware Bag / Sac de quincaillerie / Bolsa de herraje

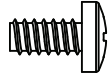

ADY (x16)



ADJ (x8)



CXK (x32)

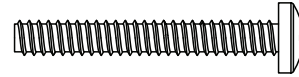

ETC (x16)

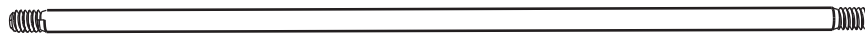

ADH (x4) — 8 1/4 in/po (20,96 cm)



PARTS REQUIRED / PIÈCES REQUISES / PIEZAS REQUERIDAS

Metal Parts / Pièces en métal / Piezas de metal



AFH (x8) — 43 1/4 in/po (1,10 m)



AFH (x8)



AFG (x4) — 40 in/po (1,02 m)



AFG (x4)

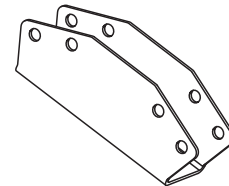

ETD (x4)



TOOLS REQUIRED / OUTILS REQUIS / INSTRUMENTAL REQUERIDO



7/16 in/po (11 mm) (x2)



3/8 in/po (10 mm)

► SECTION 2 (CONTINUED) / SECTION 2 (SUITE) / SECCIÓN 2 (CONTINUACIÓN)

TOOLS AND HARDWARE REQUIRED / OUTILS ET QUINCAILLERIE REQUIS / INSTRUMENTAL Y HERRAJE REQUERIDOS

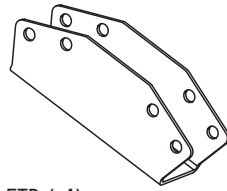

ETD (x4)



- In case of assembly problems with this section, follow the code below to view a video on the assembly in this section.
- En cas de problèmes avec cette section, suivre le code en bas pour voir un vidéo sur l'assemblage à cette section.
- En caso de problemas con esta sección, seguir el código debajo para ver un video sobre el ensamble en esta sección.



<http://go.lifetime.com/7truss>

2.1

- Align the holes in a **Connector (ETD)** with those in the ends of the **Truss Channels (AFH)**.
- Aligner les trous dans le **connecteur (ETD)** avec ceux aux extrémités des **canaux (AFH)**.
- Alinear los agujeros en el **conector (ETD)** con ellos a los extremos de los **canalones (AFH)**.

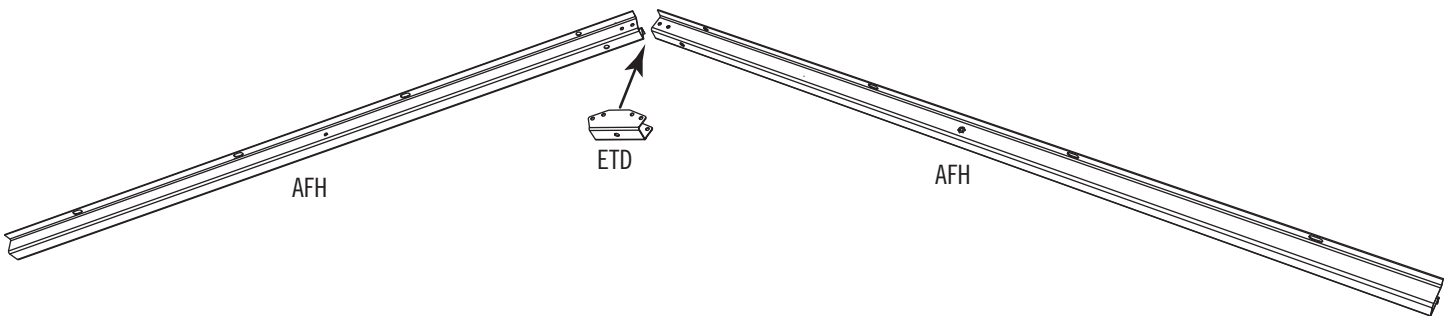

► SECTION 2 (CONTINUED) / SECTION 2 (SUITE) / SECCIÓN 2 (CONTINUACIÓN)

TOOLS AND HARDWARE REQUIRED / OUTILS ET QUINCAILLERIE REQUIS / INSTRUMENTAL Y HERRAJE REQUERIDOS

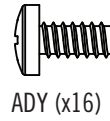
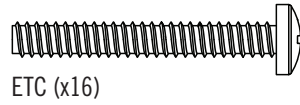

2.2

- Secure the Connector to the Truss Gutter Channels using the hardware included.
- Attacher le connecteur aux canaux à l'aide de la quincaillerie incluse.
- Sujetar el conector a los canales usando el herraje incluido.

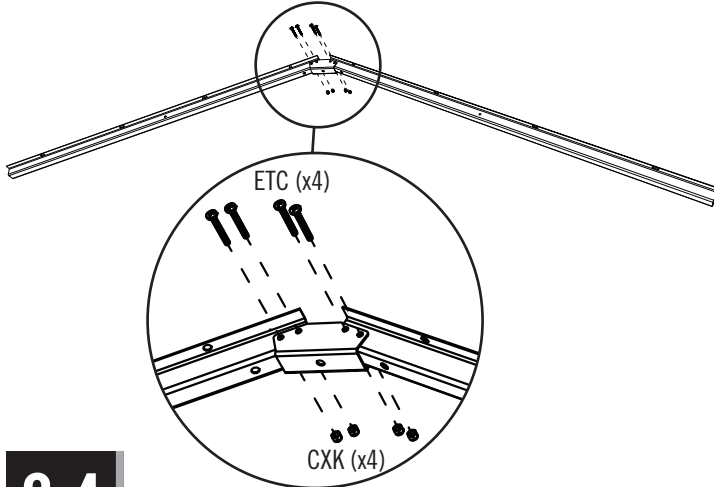

2.3

- Align the holes in a **Truss Brace (AFG)** with those in the Truss Gutter Channels.
- Aligner les trous dans le **support de la ferme (AFG)** avec ceux des canaux de gouttière.
- Alinear los agujeros en el **soporte de la cercha (AFG)** con ellos en los canalones de la cercha.

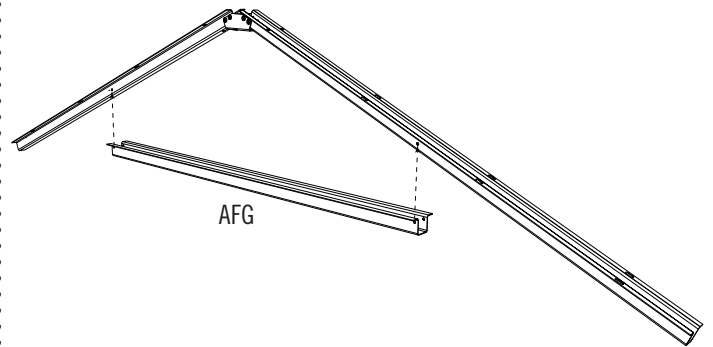

2.4

- Attach the Truss Brace to the Truss Gutter Channels using the hardware included.
- Attacher le support de ferme aux canaux à l'aide de la quincaillerie incluse.
- Sujetar el soporte de cercha a los canalones usando el herraje incluido.

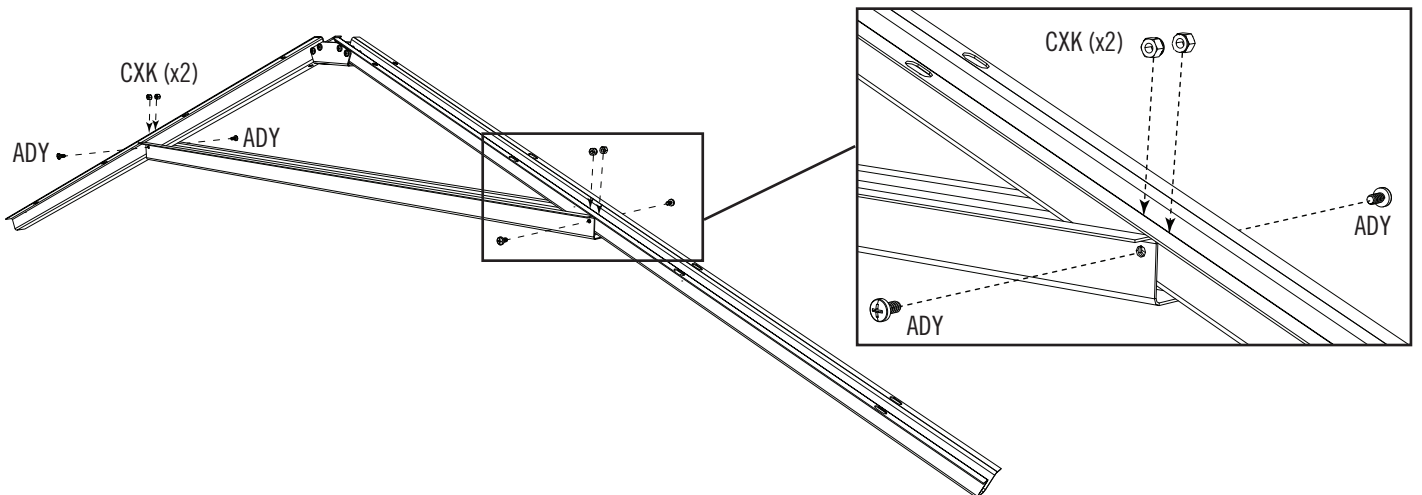

► SECTION 2 (CONTINUED) / SECTION 2 (SUITE) / SECCIÓN 2 (CONTINUACIÓN)

TOOLS AND HARDWARE REQUIRED / OUTILS ET QUINCAILLERIE REQUIS / INSTRUMENTAL Y HERRAJE REQUERIDOS



3/8 in/po
(10 mm)



7/16 in/po
(11 mm) (x2)

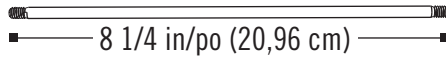

ADH (x4)

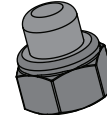

ADJ (x8)

2.5

- Slide a **Truss Rod (ADH)** through the holes in the Truss Brace and Connector. Secure with two **Cap Nuts (ADJ)**. **Lay Truss flat and tighten all hardware securely.**
- Faire glisser un **support de la ferme (ADH)** à travers les trous dans le support et le connecteur. Attacher-le bien à l'aide des **écrous borgnes (ADJ)**. **Serrer bien toute la quincaillerie.**
- Deslizar un **truss rod (ADH)** por los agujeros en el soporte y el conector. Sujetarlo bien usando las **tuercas ciegas (ADJ)**. **Apretar bien todo el herraje.**

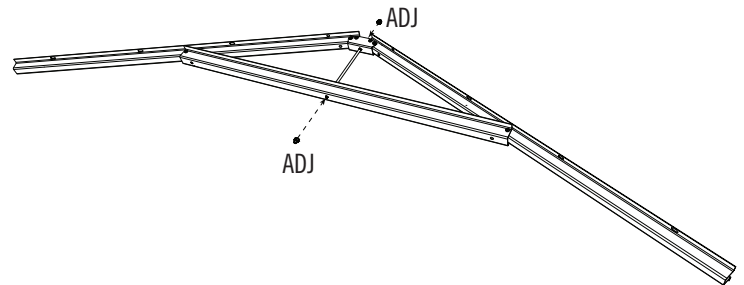
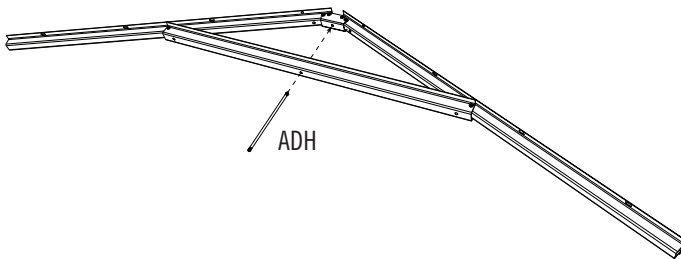

2.6

- Repeat this section three times.
- Répéter cette section trois fois.
- Repetir esta sección tres veces.

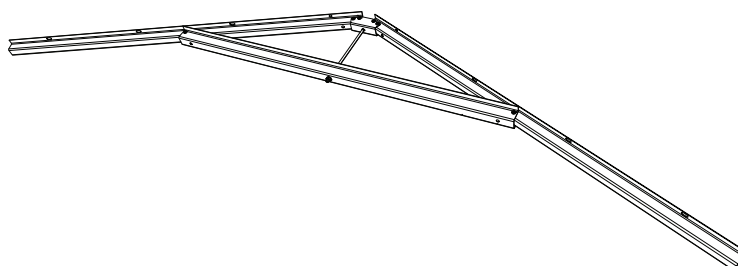
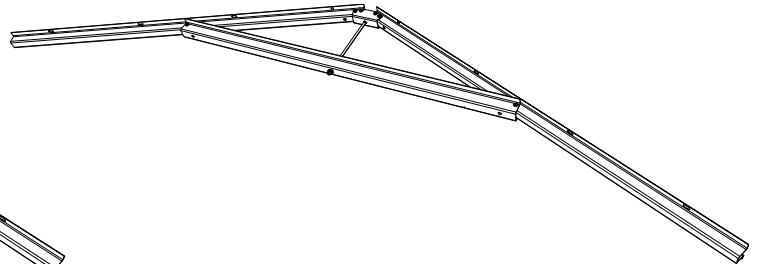
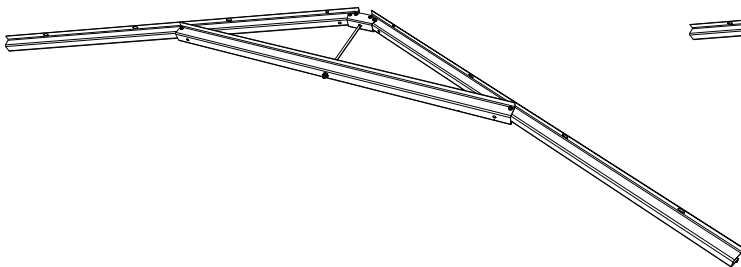

3

GABLE ASSEMBLY / ASSEMBLAGE DES PIGNONS / ENSAMBLE DE LAS FACHADAS



HARDWARE REQUIRED / QUINCAILLERIE REQUISE / HERRAJE REQUERIDO

Hardware Bag / Sac de quincaillerie / Bolsa de herraje

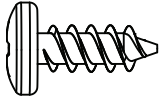

ADZ (x3)

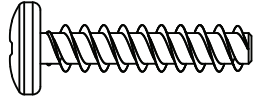

ADV (x6)



PARTS REQUIRED / PIÈCES REQUISES / PIEZAS REQUERIDAS

Metal Parts / Pièces en métal / Piezas de metal

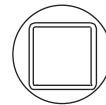
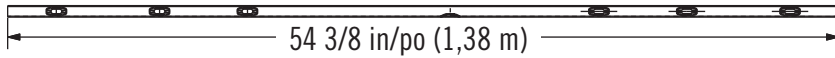

AFE (x1)

Plastic Parts / Pièces en plastique / Piezas de plástico



AGF (x1)

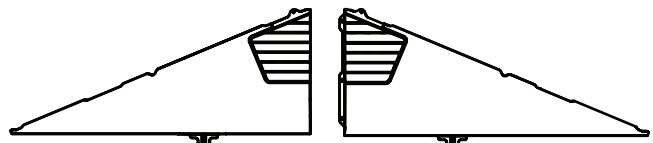

AGI (x1)

AGH (x1)



TOOLS REQUIRED / OUTILS REQUIS / INSTRUMENTAL REQUERIDO



► SECTION 3 (CONTINUED) / SECTION 3 (SUITE) / SECCIÓN 3 (CONTINUACIÓN)

TOOLS AND HARDWARE REQUIRED / OUTILS ET QUINCAILLERIE REQUIS / INSTRUMENTAL Y HERRAJE REQUERIDOS

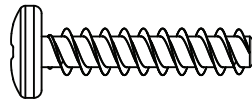

ADV (x6)

3.1

- Align the holes in the **Lintel (AFE)** with those in the **Entry Gable (AGF)**.
- Aligner les trous dans le **linteau (AFE)** avec ceux du **pignon d'entrée (AGF)**.
- Alinear los agujeros en el **dintel (AFE)** con ellos en la **fachada de entrada (AGF)**.

- The flat holes face away from the Gable.
- Les trous plats doivent être face à l'écart du pignon.
- Los agujeros planos dan hacia afuera.

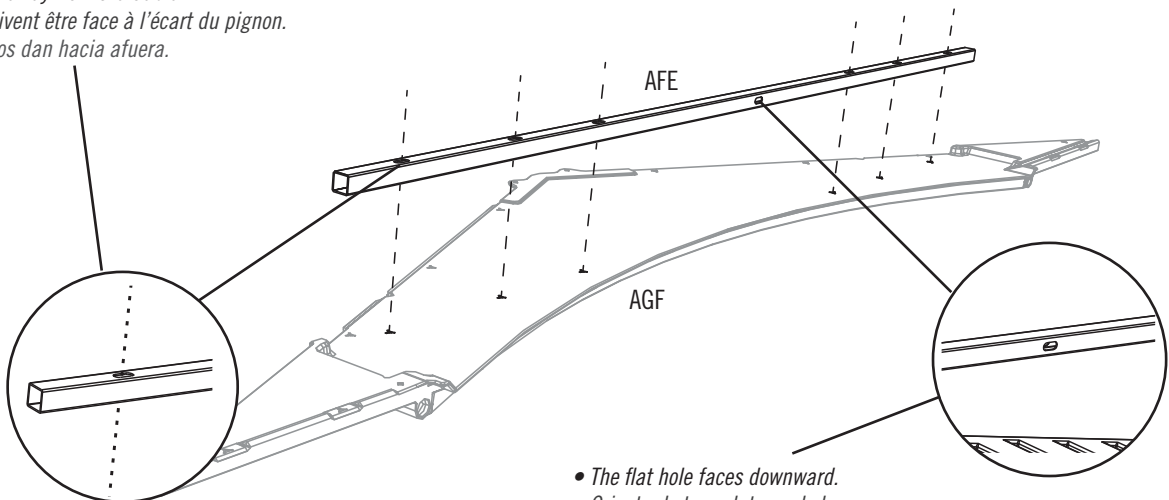

- The flat hole faces downward.
- Orienter le trou plat vers le bas.
- Orientar el agujero plano hacia abajo.

3.2

- Secure with the hardware included.
- Fixer les uns aux autres en utilisant la quincaillerie incluse.
- Fijar los unos a los otros usando el herraje incluido.

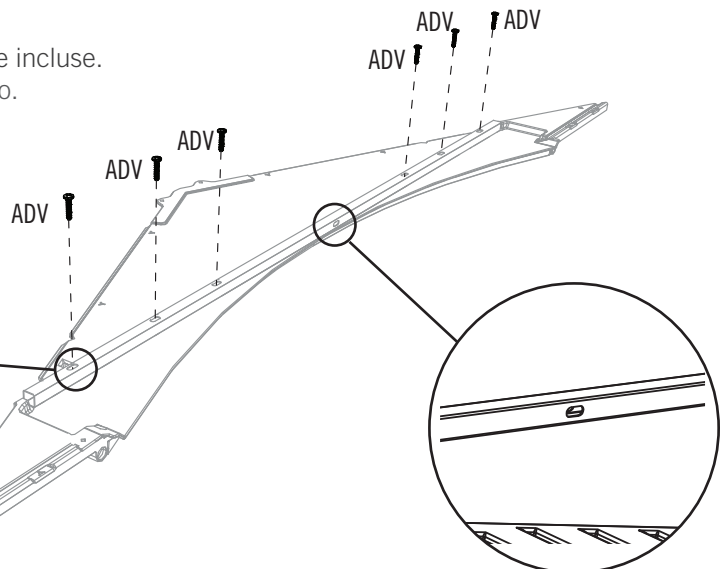
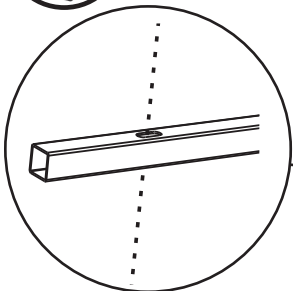

► SECTION 3 (CONTINUED) / SECTION 3 (SUITE) / SECCIÓN 3 (CONTINUACIÓN)

TOOLS AND HARDWARE REQUIRED / OUTILS ET QUINCAILLERIE REQUIS / INSTRUMENTAL Y HERRAJE REQUERIDOS

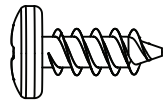

ADZ (x3)

3.3

- Align the holes in the **Left (AGH)** and **Right (AGI)** Rear Gable Halves.
- Aligner les trous dans les **toits à pignons gauche (AGH)** et **droite (AGI)**.
- Alinear los agujeros en las **fachadas traseras izquierda (AGH)** y **derecha (AGI)**.

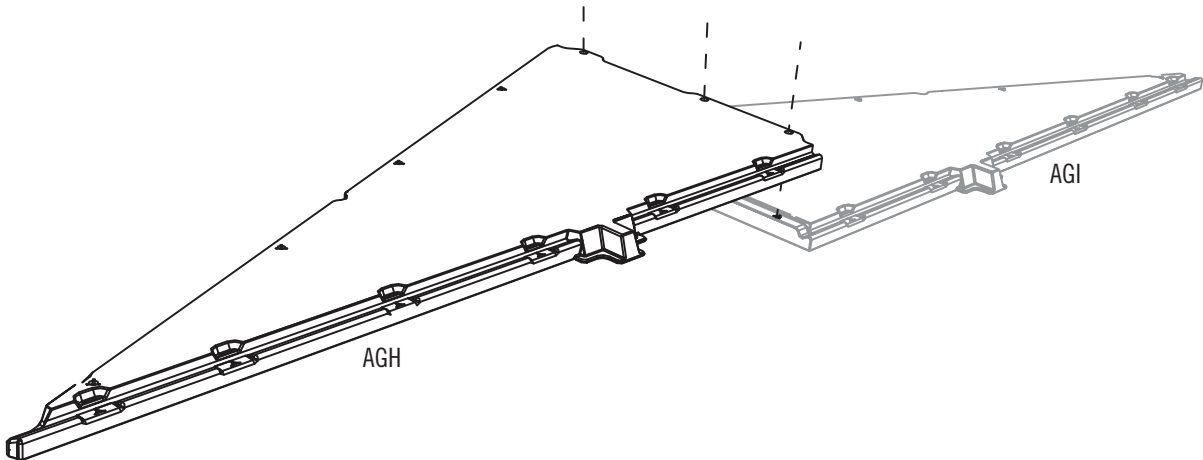

3.4

- Secure the two together with three (3) **Screws (ADZ)**.
- Fixer l'un à l'autre à l'aide de trois (3) **vis (ADZ)**.
- Fijar el uno al otro usando tres (3) **tornillos (ADZ)**.

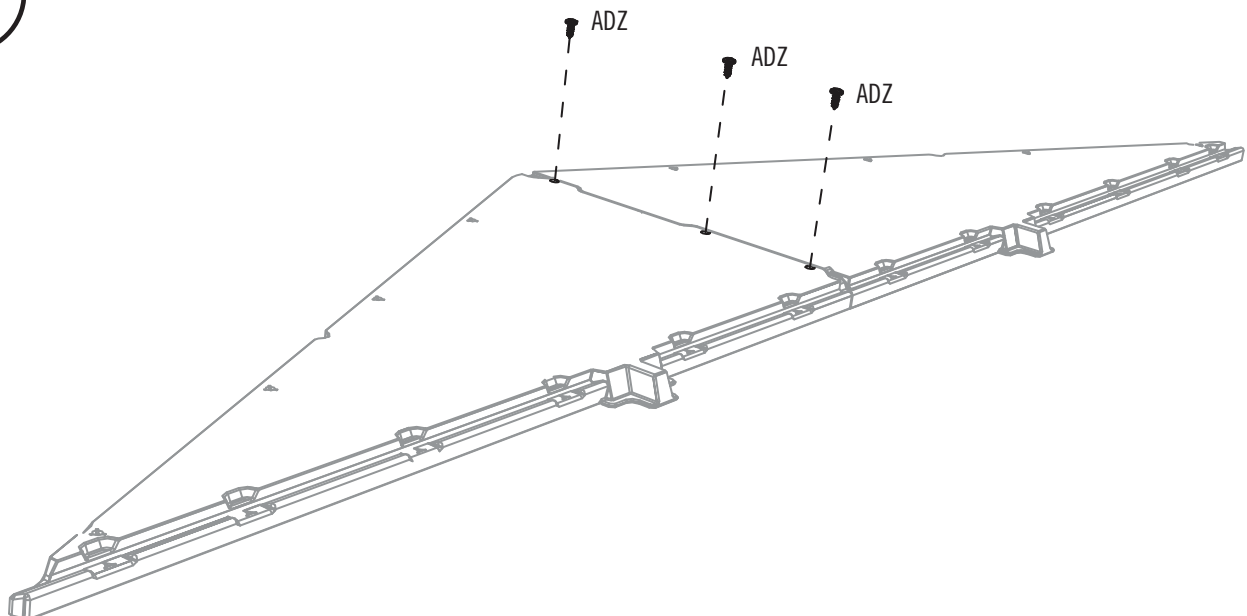

4

LEFT DOOR ASSEMBLY / ASSEMBLAGE DE LA PORTE GAUCHE / ENSAMBLE DE LA PUERTA IZQUIERDA



HARDWARE REQUIRED / QUINCAILLERIE REQUISE / HERRAJE REQUERIDO

Hardware Bag / Sac de quincaillerie / Bolsa de herraje

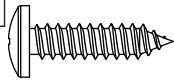

ADW (x1)

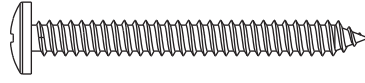

BYZ (x2)

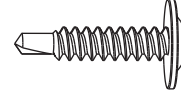

CHK (x5)

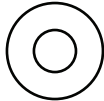

AEE (x3)

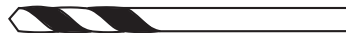

ARA (x1)

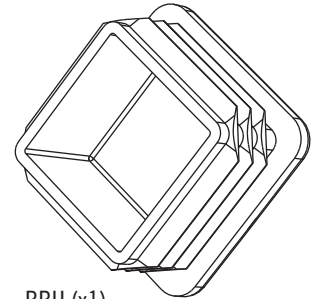

BBH (x1)

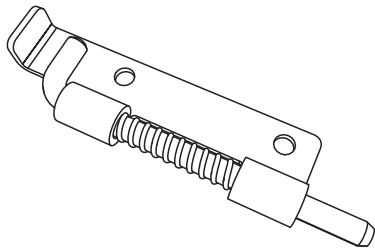

DGR (x1) (Bottom / Inférieur / Inferior)

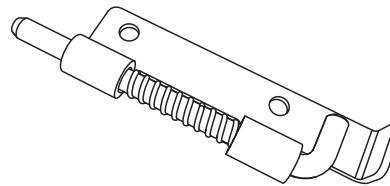

DGS (x1) (Top / Supérieur / Superior)



PARTS REQUIRED / PIEZAS REQUERIDAS / PIÈCES REQUISES

Metal Parts / Pièces en métal / Piezas de metal

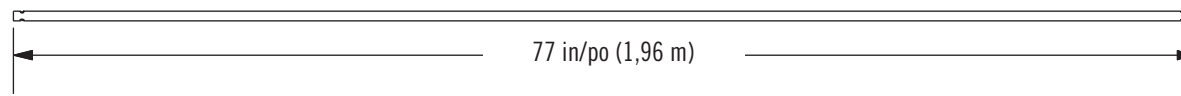

CHH (x1)

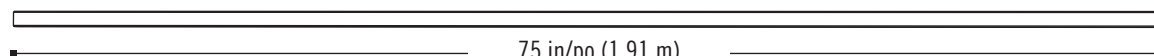

CHI (x1)

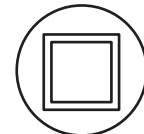

4

LEFT DOOR ASSEMBLY / ASSEMBLAGE DE LA PORTE GAUCHE / ENSAMBLE DE LA PUERTA IZQUIERDA



PARTS REQUIRED / PIEZAS REQUERIDAS / PIÈCES REQUISES

Plastic Parts / Pièces en plastique / Piezas de plástico



BYS (x1)



BYR (x1)

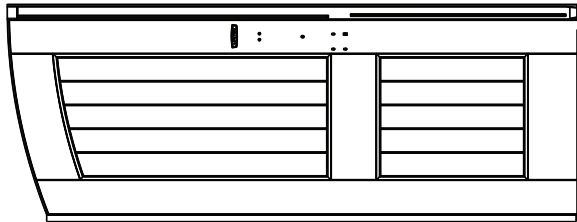

AGO (x1)



TOOLS REQUIRED / OUTILS REQUIS / INSTRUMENTAL REQUERIDO

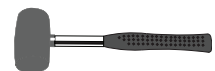

► SECTION 4 (CONTINUED) / SECTION 4 (SUITE) / SECCIÓN 4 (CONTINUACIÓN)

TOOLS AND HARDWARE REQUIRED / OUTILS ET QUINCAILLERIE REQUIS / INSTRUMENTAL Y HERRAJE REQUERIDOS

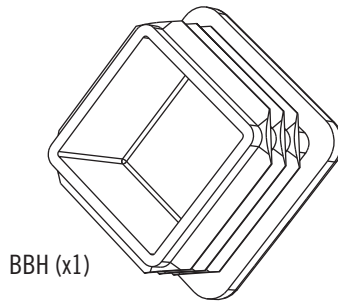

4.1

- Slide a **Hinge Tube (CHH)** down into the hole in the **Left Door (AGO)**.
- Faire glisser le **tube d'articulation (CHH)** dans le trou dans la **porte gauche (AGO)**.
- Deslizar el **tubo de articulación (CHH)** en el agujero en la **puerta izquierda (AGO)**.

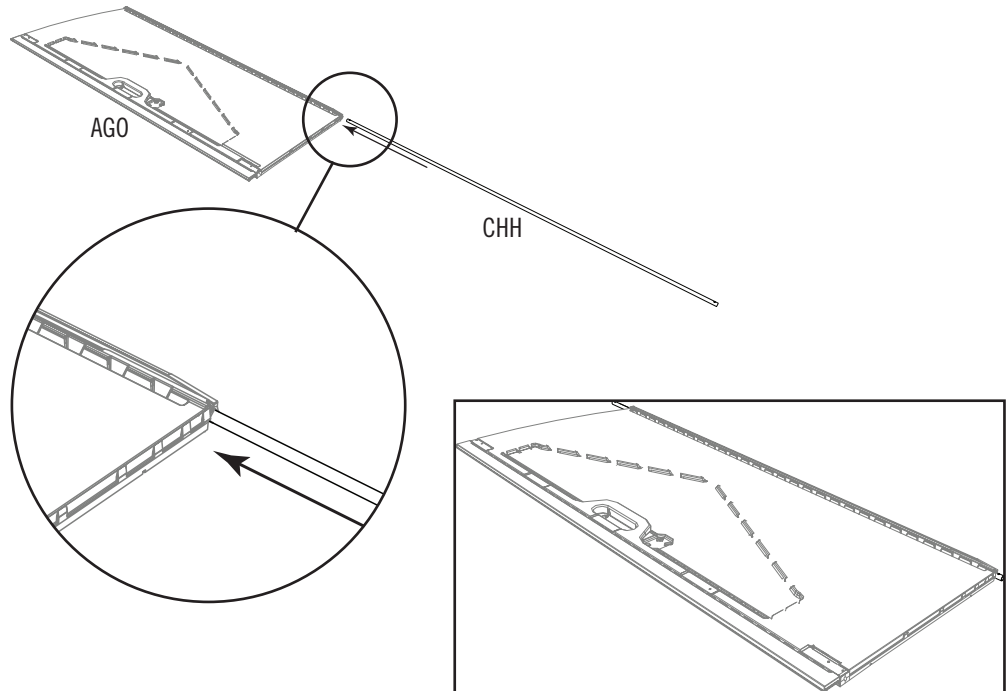

4.2

- Insert a **Square Tube (CHI)** into the square hole in the bottom of the Door until the end hangs out about 6" (15 cm).
- Insérer un **tube carré (CHI)** dans le trou carré au fond de la port jusqu'à ce que l'extrémité dépasse à peu près 15 cm (6").
- Insertar un **tubo cuadrado (CHI)** en el agujero cuadrado al fondo de la puerta hasta que el extremo extienda unos 15 cm (6").

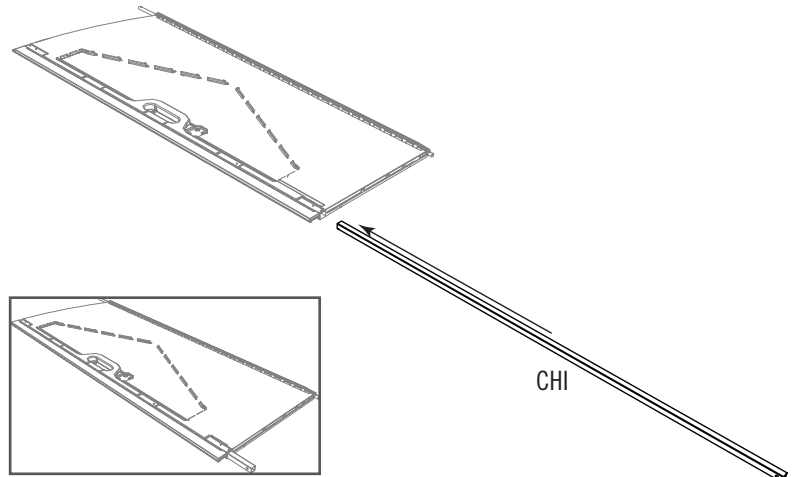

► SECTION 4 (CONTINUED) / SECTION 4 (SUITE) / SECCIÓN 4 (CONTINUACIÓN)

TOOLS AND HARDWARE REQUIRED / OUTILS ET QUINCAILLERIE REQUIS / INSTRUMENTAL Y HERRAJE REQUERIDOS

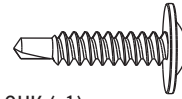

CHK (x1)

4.3

- Insert an **End Cap (BBH)** into the end of the **Square Tube (CHI)**. Gently, finish inserting the Tube until it's flush with the bottom of the Door.
- Insérer un **capuchon (BBH)** dans l'extrémité du **tube carré (CHI)**. Insérer gentiment le tube jusqu'à ce qu'il soit aligné avec le fond de la porte.
- Insertar un **tapón (BBH)** en el extremo del **tubo cuadrado (CHI)**. Insertar ligeramente el tubo hasta que esté alineado con el fondo de la puerta.

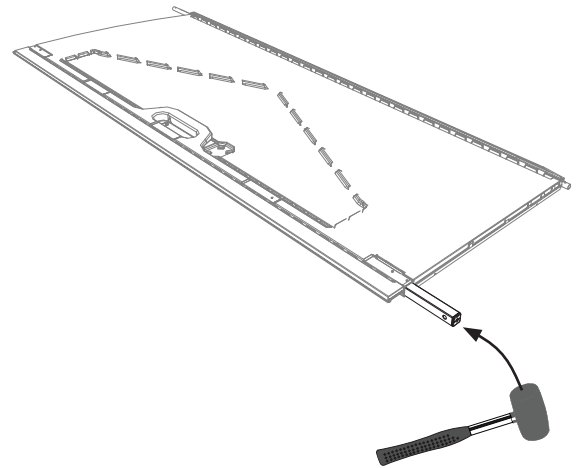
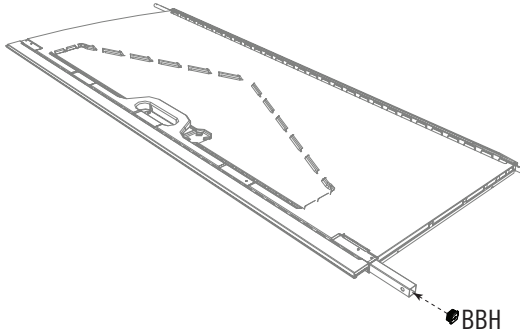

4.4

- Once the End Cap is flush with the bottom of the Door, insert **Self-Drilling/Self-Tapping Screw (CHK)** into the Door Panel at the location shown to hold the Square Tube in place.
- Une fois que le capuchon soit a ras du bord inférieur de la porte, insérer une **vis autoperceuse/autotaraudeuse (CHK)** dans la porte à l'emplacement indiqué pour maintenir le tube carré en place.
- Una vez que el tapón esté a ras del borde inferior de la puerta, insertar un **tornillo auto-perforante/auto-roscante (CHK)** en la puerta a la ubicación ilustrada para mantener el tubo cuadrado en su lugar.

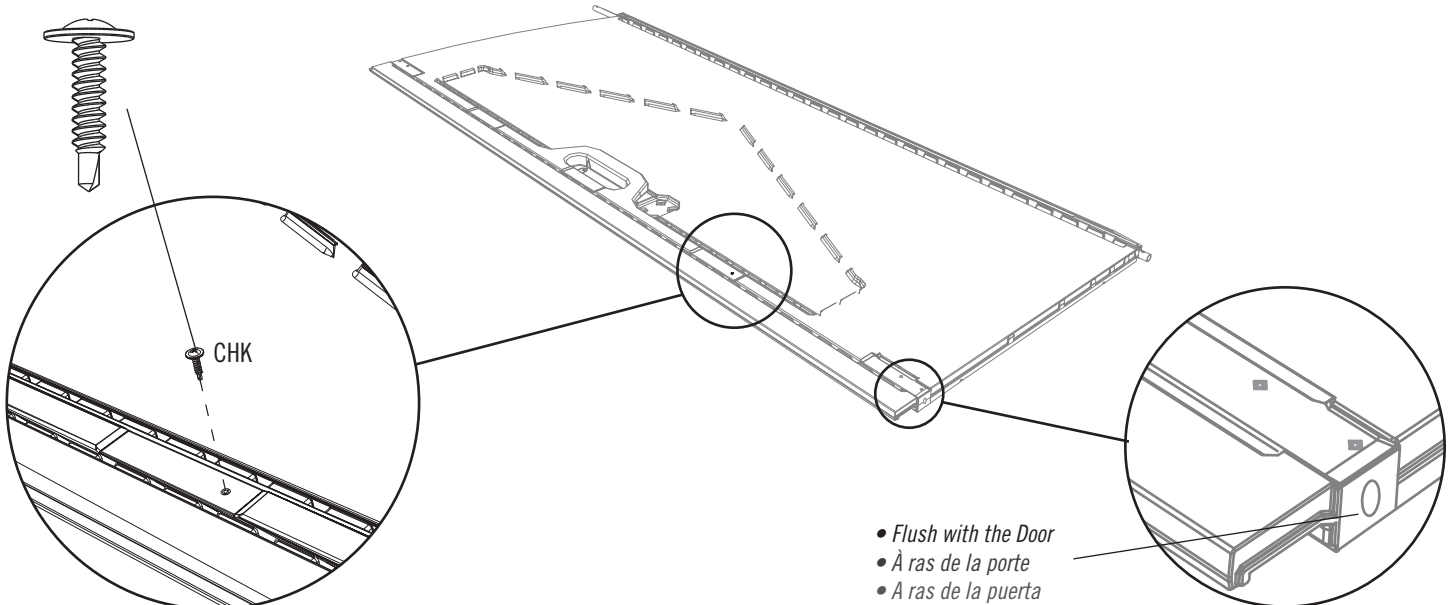

► SECTION 4 (CONTINUED) / SECTION 4 (SUITE) / SECCIÓN 4 (CONTINUACIÓN)

TOOLS AND HARDWARE REQUIRED / OUTILS ET QUINCAILLERIE REQUIS / INSTRUMENTAL Y HERRAJE REQUERIDOS



ARA (x1)

4.5

- Drill two holes at the top and bottom of the Door at the locations indicated.
- Percer deux trous aux parties supérieur et inférieur de la porte aux emplacements indiqués.
- Taladrar dos agujeros a las partes superior e inferior de la puerta a las ubicaciones indicadas.

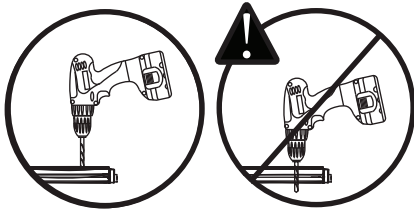
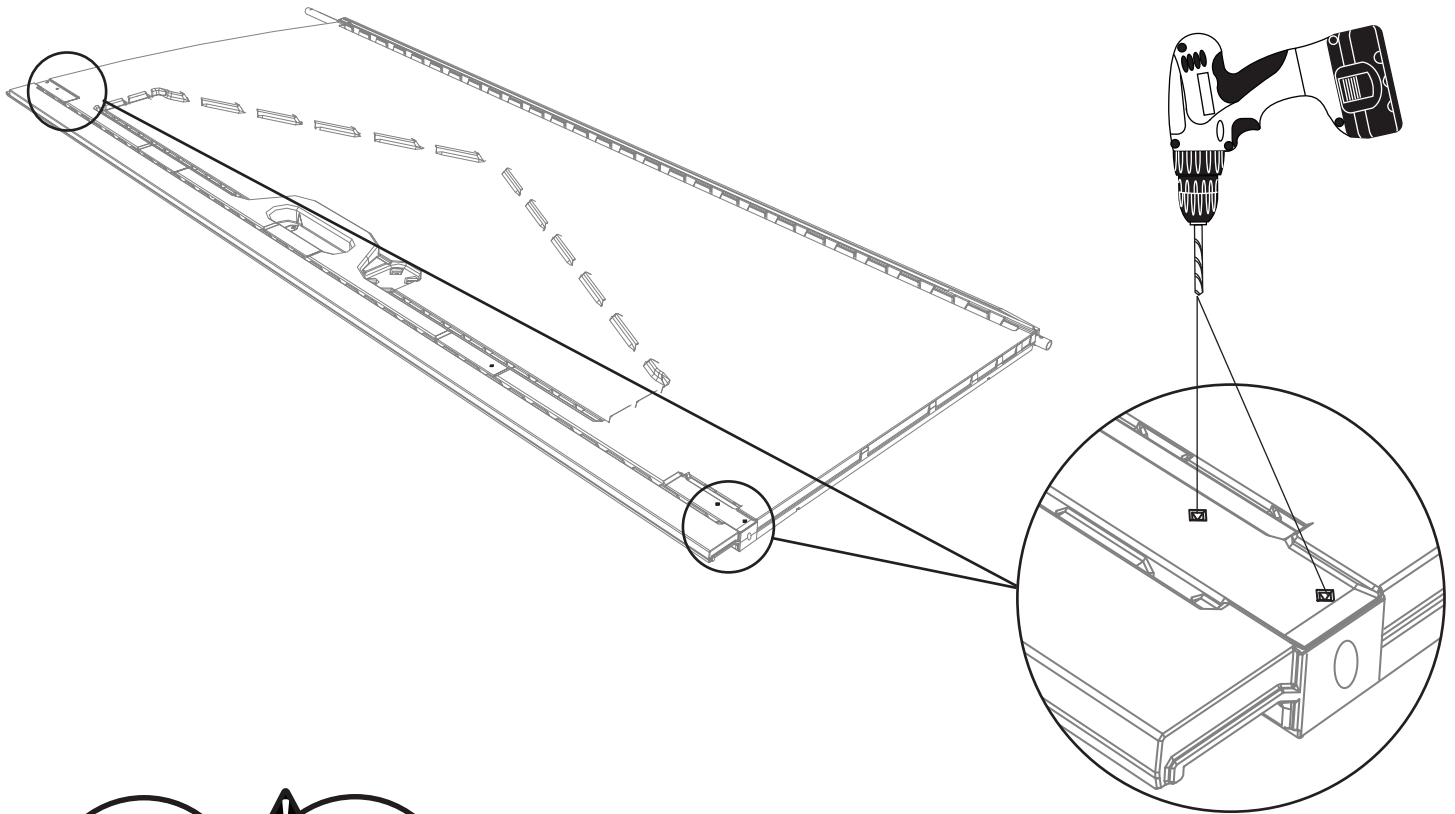

► SECTION 4 (CONTINUED) / SECTION 4 (SUITE) / SECCIÓN 4 (CONTINUACIÓN)

TOOLS AND HARDWARE REQUIRED / OUTILS ET QUINCAILLERIE REQUIS / INSTRUMENTAL Y HERRAJE REQUERIDOS

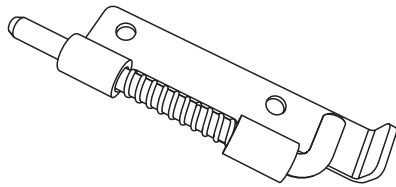

DGS (x1) (Top / Supérieur / Superior)

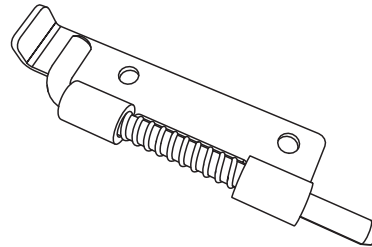

DGR (x1) (Bottom / Inférieur / Inferior)

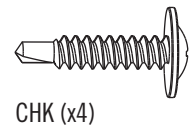

CHK (x4)

4.6

- Secure the two **Deadbolts (DGR & DGS)** to the top and bottom of the Door using the hardware provided. The Deadbolts should move freely. If they do not, loosen the Screws a tad.
- Attacher bien les deux **verrous (DGR et DGS)** aux parties supérieure et inférieure de la porte en utilisant la quincaillerie incluse. Les verrous doivent faire glisser librement. Si non, desserrer un peu les vis.
- Sujetar bien los **cerrojos (DGR y DGS)** a las partes superior e inferior de la puerta usando el herraje incluido. Los cerrojos deben mover libremente. Si no, aflojar un poco los tornillos.

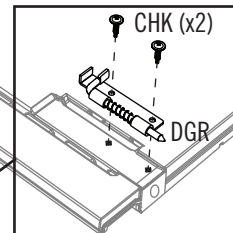
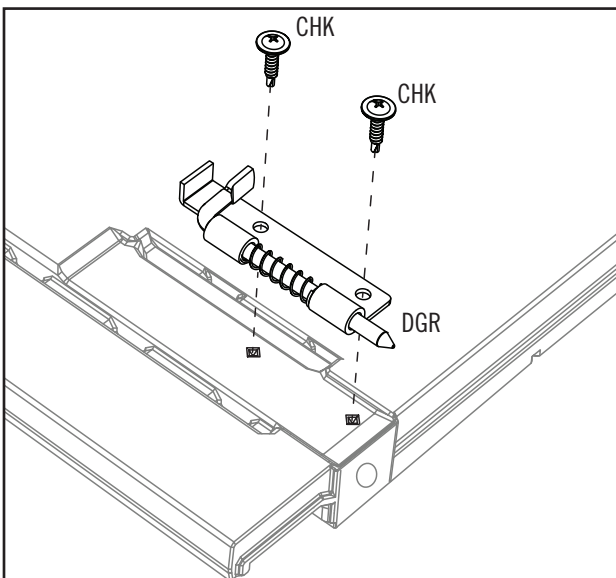
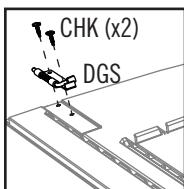

► SECTION 4 (CONTINUED) / SECTION 4 (SUITE) / SECCIÓN 4 (CONTINUACIÓN)

TOOLS AND HARDWARE REQUIRED / OUTILS ET QUINCAILLERIE REQUIS / INSTRUMENTAL Y HERRAJE REQUERIDOS

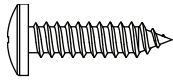

ADW (x1)

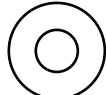

AEE (x3)

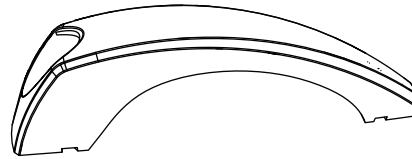

BYS (x1)

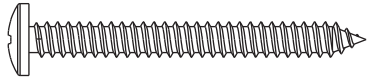

BYZ (x2)



BYR (x1)

4.7

- Attach the **Handle pieces (BYR & BYS)** using the hardware provided.
- Attacher les **pièces de la poignée (BYR et BYS)** à l'aide de la quincaillerie incluse.
- Sujetar las **piezas del picaporte (BYR y BYS)** usando el herraje incluido.

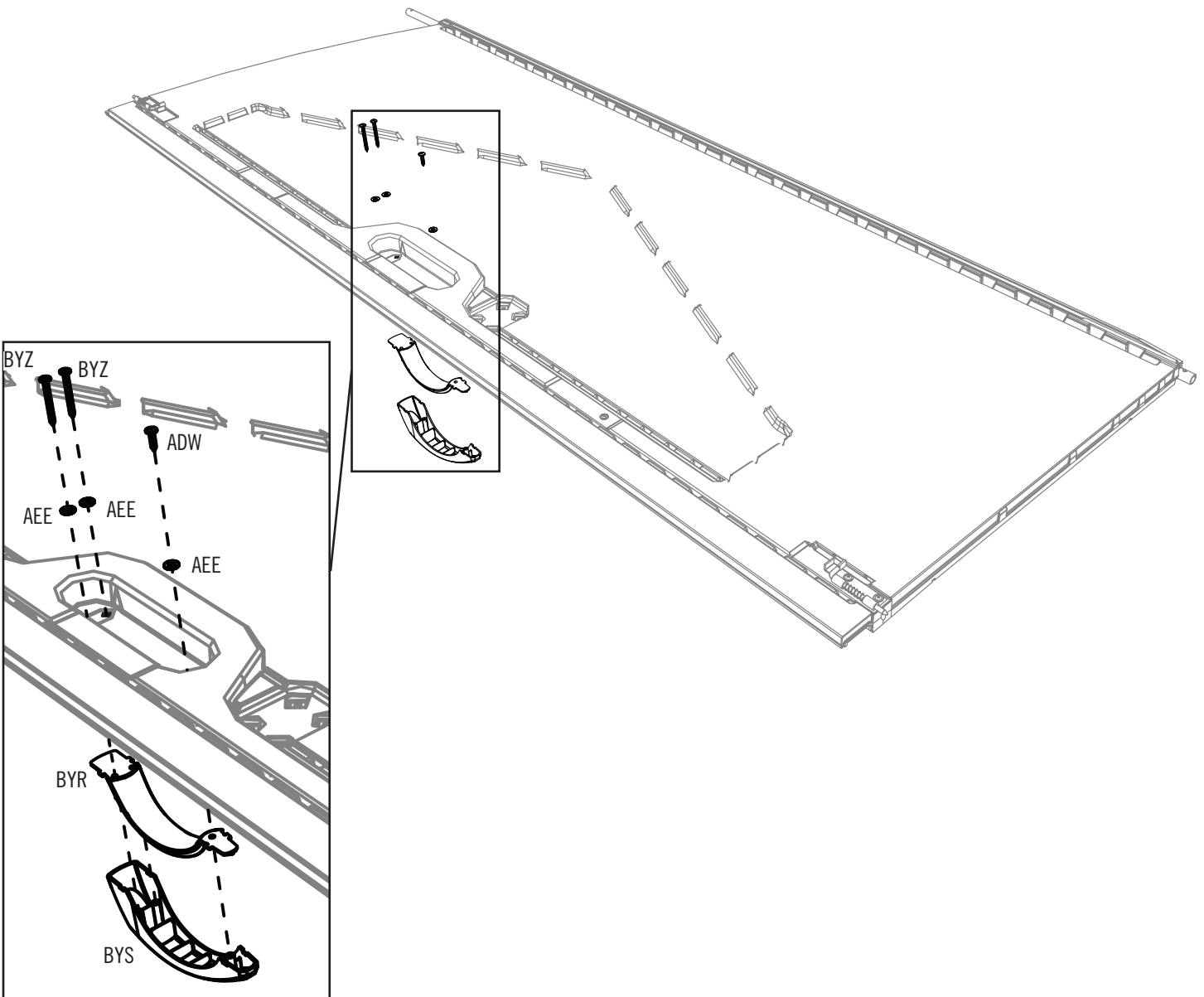

5

RIGHT DOOR ASSEMBLY / ASSEMBLAGE DE LA PORTE DROITE / ENSAMBLE DE LA PUERTA DERECHA



HARDWARE REQUIRED / QUINCAILLERIE REQUISE / HERRAJE REQUERIDO

Hardware Bag / Sac de quincaillerie / Bolsa de herraje

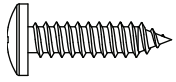

ADW (x1)

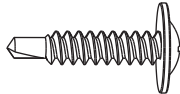

CHK (x1)

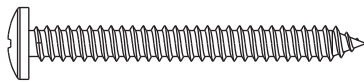

BYZ (x2)

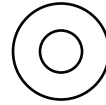

AEE (x1)

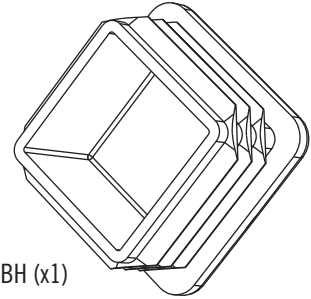

BBH (x1)

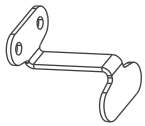

BBI (x1)



PARTS REQUIRED / PIÈCES REQUISES / PIEZAS REQUERIDAS

Metal Parts / Pièces en métal / Piezas de metal

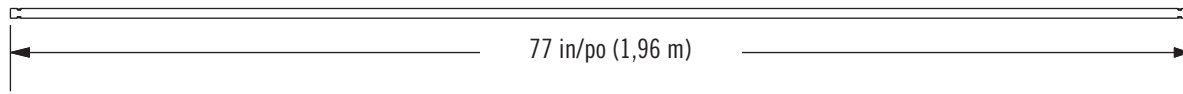

CHH (x1)

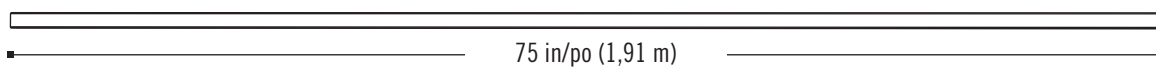

CHI (x1)

Plastic Parts / Pièces en plastique / Piezas de plástico

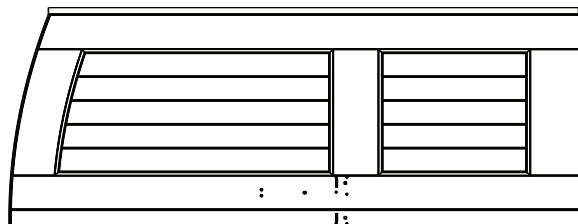

AGZ (x1)

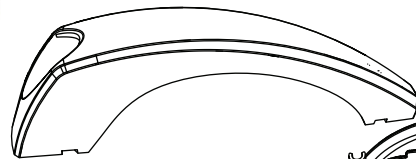

BYS (x1)



BYR (x1)



TOOLS REQUIRED / OUTILS REQUIS / INSTRUMENTAL REQUERIDO

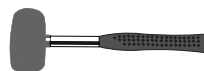

► SECTION 5 (CONTINUED) / SECTION 5 (SUITE) / SECCIÓN 5 (CONTINUACIÓN)

TOOLS AND HARDWARE REQUIRED / OUTILS ET QUINCAILLERIE REQUIS / INSTRUMENTAL Y HERRAJE REQUERIDOS



5.1

- Slide a **Hinge Tube (CHH)** down into the hole in the **Right Door (AGZ)**.
- Faire glisser le **tube d'articulation (CHH)** dans le trou dans la **porte droite (AGZ)**.
- Deslizar el **tubo de articulación (CHH)** en el agujero en la **puerta derecha (AGZ)**.

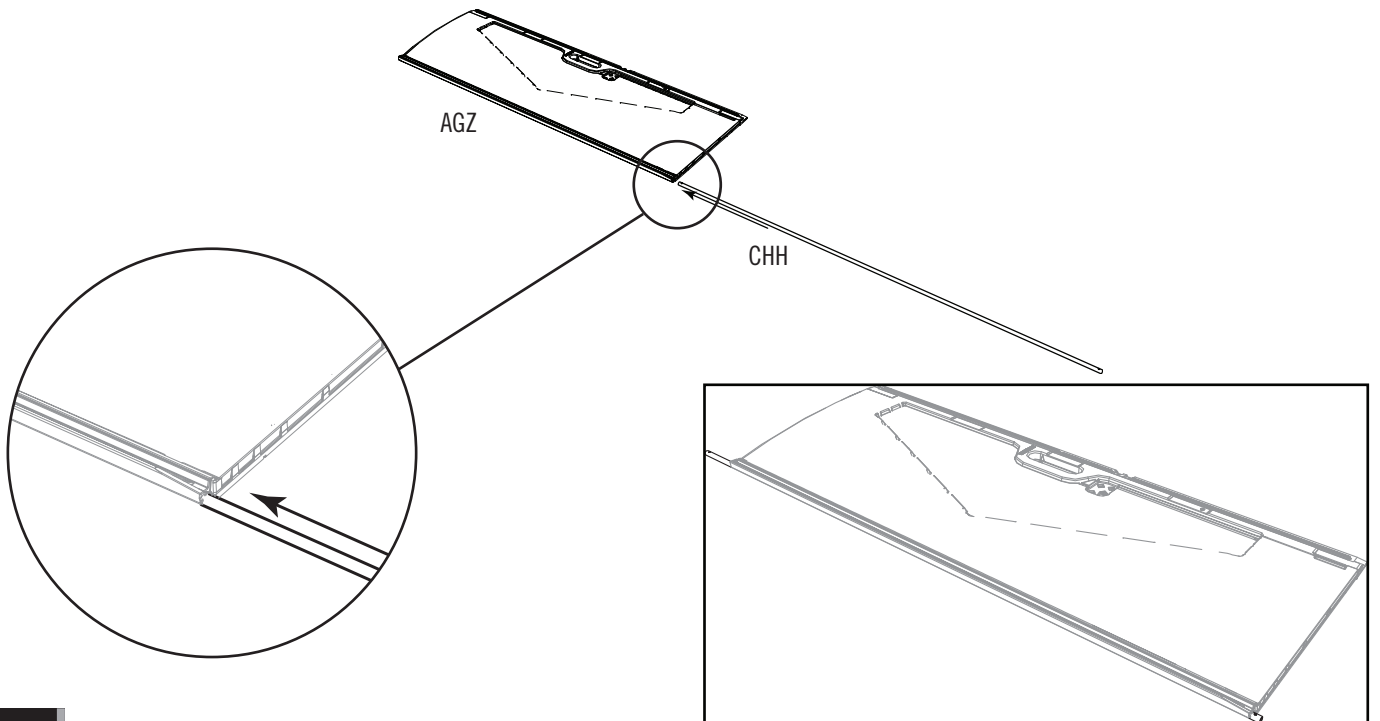

5.2

- Insert a **Square Tube (CHI)** into the square hole in the bottom of the Door until the end hangs out about 6" (15 cm).
- Insérer un **tube carré (CHI)** dans le trou carré au fond de la port jusqu'à ce que l'extrémité dépasse à peu près 15 cm (6").
- Introducir un **tubo cuadrado (CHI)** en el agujero cuadrado al fondo de la puerta hasta que el extremo extienda unos 15 cm (6").

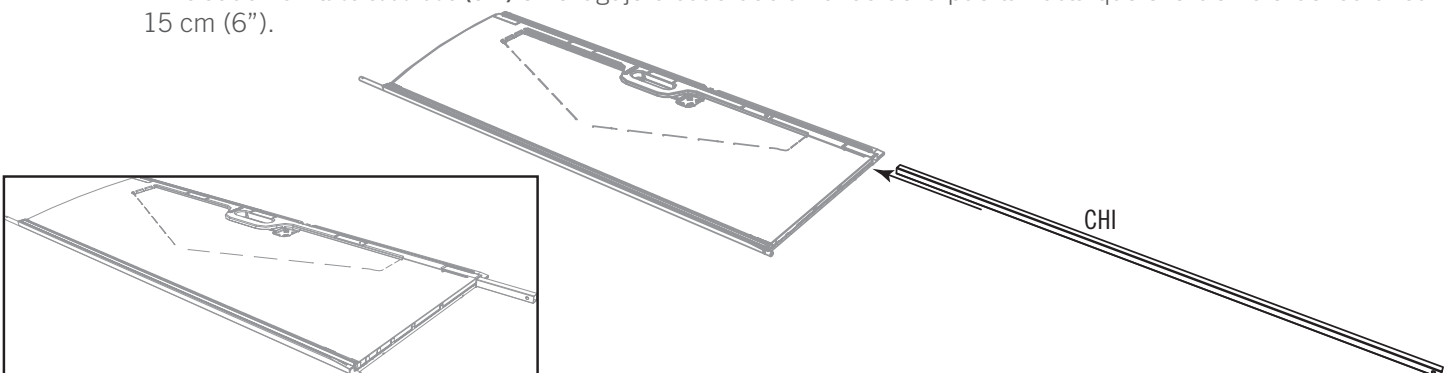

► SECTION 5 (CONTINUED) / SECTION 5 (SUITE) / SECCIÓN 5 (CONTINUACIÓN)

TOOLS AND HARDWARE REQUIRED / OUTILS ET QUINCAILLERIE REQUIS / INSTRUMENTAL Y HERRAJE REQUERIDOS



ARA (x1)

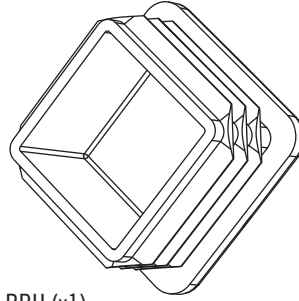

BBH (x1)

5.3

- Insert an **End Cap (BBH)** into the end of the **Square Tube (CHI)**. Gently, finish inserting the Tube until it's flush with the bottom of the Door.
- Insérer un **capuchon (BBH)** dans l'extrémité du **tube carré (CHI)**. Insérer gentiment le tube jusqu'à ce qu'il soit aligné avec le fond de la porte.
- Insertar un **tapón (BBH)** en el extremo del **tubo cuadrado (CHI)**. Insertar ligeramente el tubo hasta que esté alineado con el fondo de la puerta.

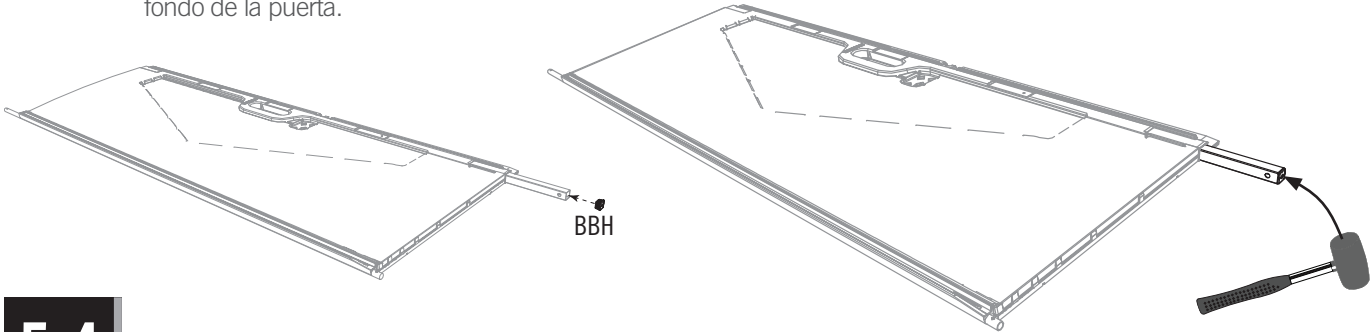

5.4

- Using an **1/8" (6,4 mm) Drill Bit (ARA)**, drill through the Door and into the Square Tube. Do not drill all the way through the Door—just into the Tube.
- En utilisant un **foret de 6,4 mm (1/8") (ARA)**, percer la porte et le tube carré. Ne percer pas complètement à travers la porte — juste dans le tube.
- Usando una **broca de 6,4 mm (1/8") (ARA)**, taladrar la puerta y el tubo cuadrado. No taladrar por la puerta entera—sólo al tubo.

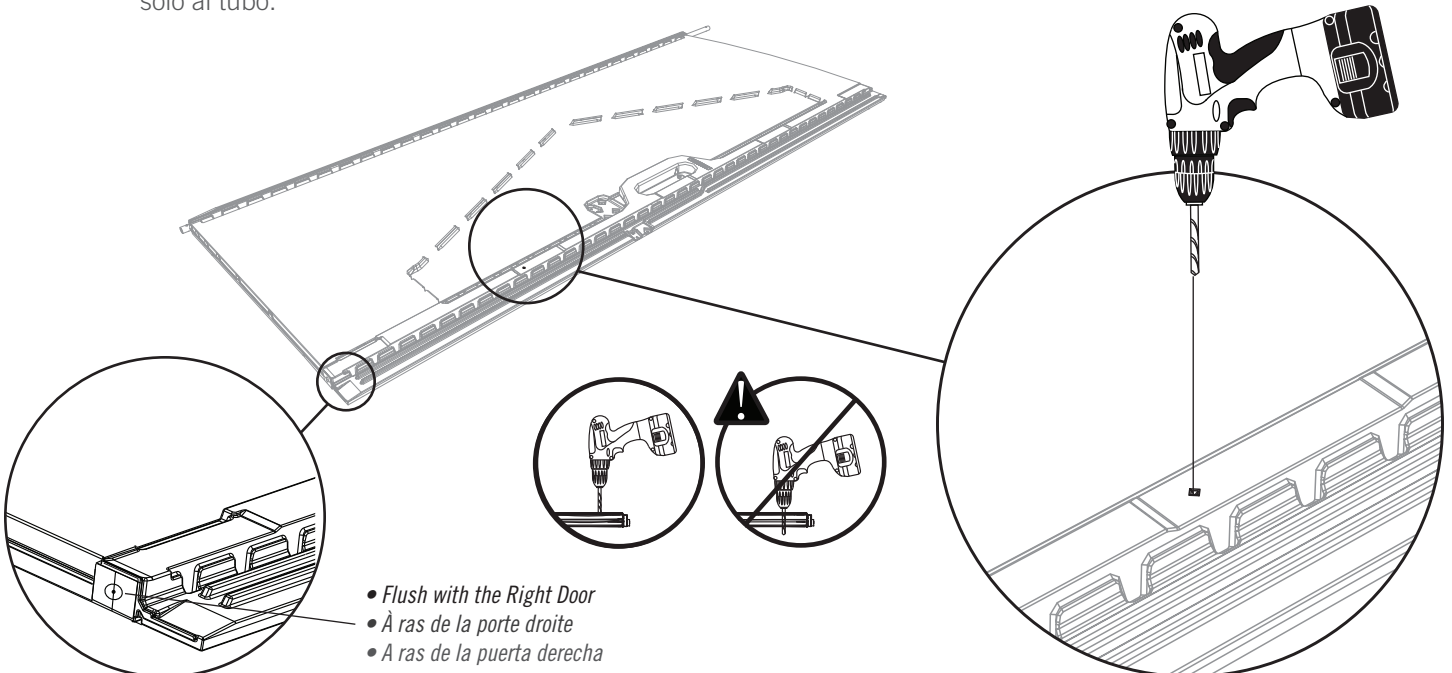

- *Flush with the Right Door*
- *À ras de la porte droite*
- *A ras de la puerta derecha*

► SECTION 5 (CONTINUED) / SECTION 5 (SUITE) / SECCIÓN 5 (CONTINUACIÓN)

TOOLS AND HARDWARE REQUIRED / OUTILS ET QUINCAILLERIE REQUIS / INSTRUMENTAL Y HERRAJE REQUERIDOS

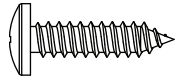

ADW (x1)

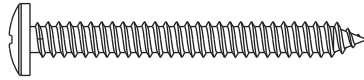

BYZ (x2)



BYS (x1)

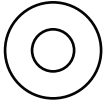

AEE (x1)

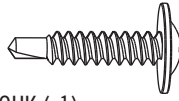

CHK (x1)

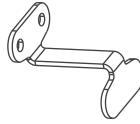

BBI (x1)



BYR (x1)

5.5

- Once the End Cap is flush with the bottom of the Door, insert **Self-Drilling/Self-Tapping Screw (CHK)** into the Door Panel at the location shown to hold the Square Tube in place.
- Une fois que le capuchon soit à ras du bord inférieur de la porte, insérer une **vis autoperceuse/autotaraudeuse (CHK)** dans la porte à l'emplacement indiqué pour maintenir le tube carré en place.
- Una vez que el tapón esté a ras del borde inferior de la puerta, insertar un **tornillo auto-perforante/auto-roscante (CHK)** en la puerta a la ubicación ilustrada para mantener el tubo cuadrado en su lugar.

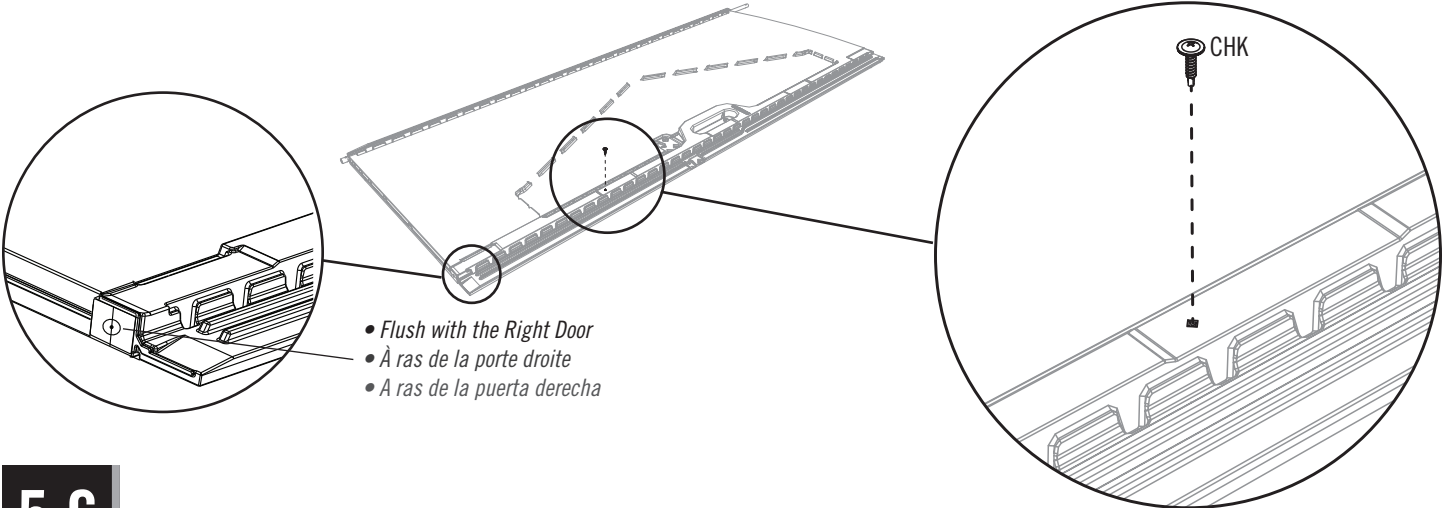

5.6

- Attach the **Handle pieces (BYR & BYS)** using the hardware provided.
- Attacher les **pièces de la poignée (BYR et BYS)** à l'aide de la quincaillerie incluse.
- Sujetar las **piezas del picaporte (BYR y BYS)** usando el herraje incluido.

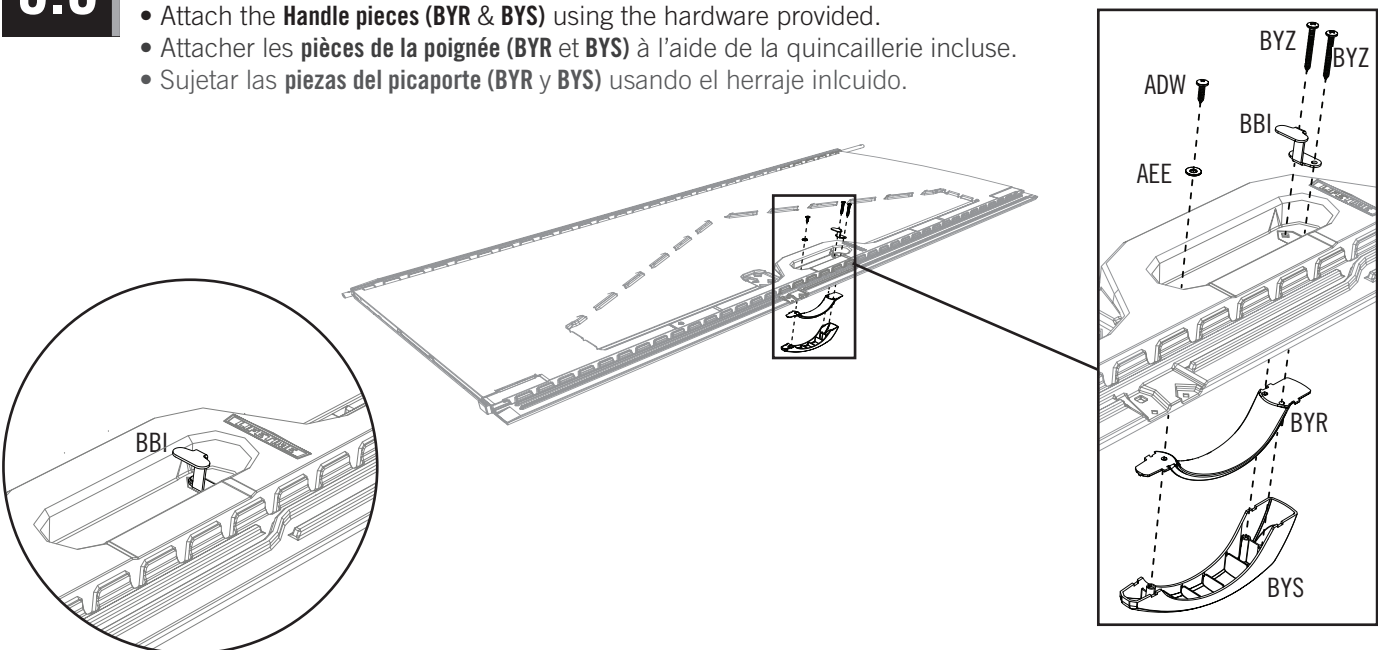

6

FLOOR ASSEMBLY / ASSEMBLAGE DU PLANCHER / ENSAMBLE DEL PISO



HARDWARE REQUIRED / QUINCAILLERIE REQUISE / HERRAJE REQUERIDO

Hardware Bag / Sac de quincaillerie / Bolsa de herraje

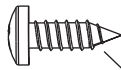
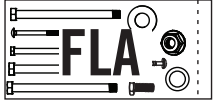

BQC (x16)

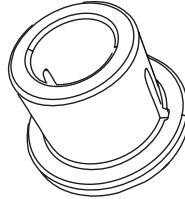

AHO (x2)



ADC (x1)



Note: These Screws do not anchor the Floor; they only hold the Panels together.

Remarque : Ces vis n'ancrent pas le plancher ; ils ne servent que pour attacher les panneaux les uns aux autres.

Nota: Estos tornillos no anclan el piso; sirven sólo para sujetar los paneles los unos a los otros.



PARTS REQUIRED / PIÈCES REQUISES / PIEZAS REQUERIDAS

Plastic Parts / Pièces en plastique / Piezas de plástico

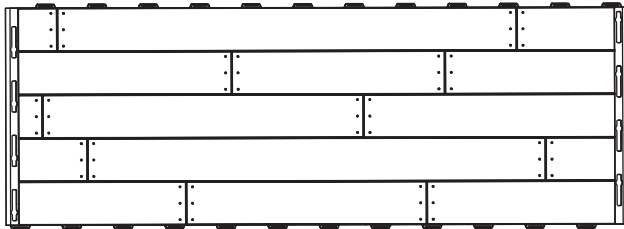

AFX (x3)

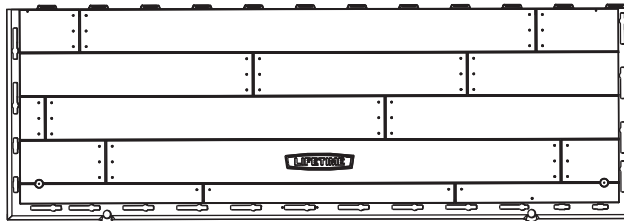

AGR (x2)



TOOLS REQUIRED / OUTILS REQUIS / INSTRUMENTAL REQUERIDO



► SECTION 6 (CONTINUED) / SECTION 6 (SUITE) / SECCIÓN 6 (CONTINUACIÓN)

TOOLS AND HARDWARE REQUIRED / OUTILS ET QUINCAILLERIE REQUIS / INSTRUMENTAL Y HERRAJE REQUERIDOS



6.1

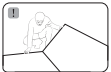

- Hold an **Inner Floor Panel (AFX)** at an angle and slide the tabs along the edge underneath the other **Outer Floor Panel (AGR)**. The tabs interlock. Lay Panel down flat. **The Doors are shown in the following images, but do not attach the Doors yet.**
- Poser un **panneau de plancher intérieur (AFX)** à un angle et faire glisser les languettes le long du bord au-dessus de l'autre **panneau de plancher extérieur (AGR)**. Les languettes s'enclenchent les uns les autres. Poser-le par terre. **Les portes se montrent dans les images suivantes, mais ne pas déjà les fixer.**
- Colocar un **panel de piso interior (AFX)** a un ángulo y deslizar las lengüetas a lo largo del borde debajo el otro **panel de piso exterior (AGR)**. Las lengüetas se entrelazan las unas con las otras. Aplanar el panel. **Se muestran las puertas en las imágenes siguientes, mas no fijar todavía las puertas.**

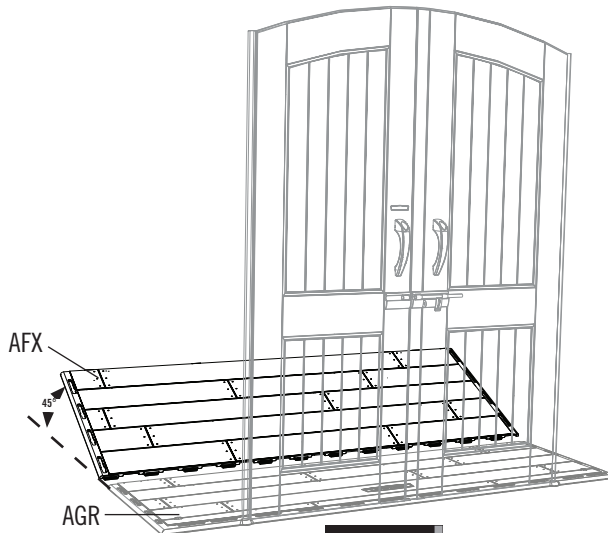

6.2

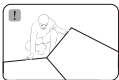

- Attach an **Inner Floor Panel (AFX)** to the Inner Floor Panel.
- Fixer un autre **panneau de plancher intérieur (AFX)** au panneau de plancher intérieur.
- Fijar otro **panel de piso interior (AFX)** al panel de piso interior.

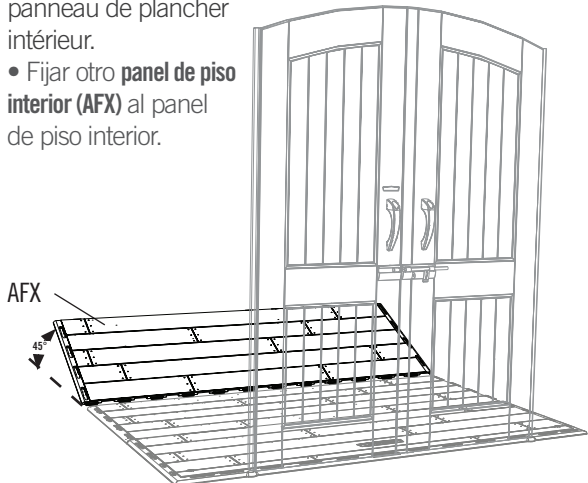

6.3

- Attach the third **Inner Floor Panel (AFX)** to the Inner Floor Panel.
- Fixer le troisième **panneau de plancher intérieur (AFX)** au deuxième panneau de plancher intérieur.
- Fijar el tercer **panel de piso interior (AFX)** al segundo panel de piso interior.



► SECTION 6 (CONTINUED) / SECTION 6 (SUITE) / SECCIÓN 6 (CONTINUACIÓN)

TOOLS AND HARDWARE REQUIRED / OUTILS ET QUINCAILLERIE REQUIS / INSTRUMENTAL Y HERRAJE REQUERIDOS

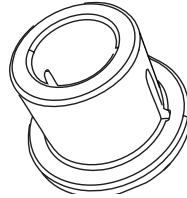

AHO (x2)

6.4

- Attach the last **Outer Floor Panel (AGR)** to the Inner Floor Panel.
- Fixer le dernière **panneau de plancher extérieur (AGR)** au panneau de plancher intérieur.
- Fijar el último **panel de piso exterior (AGR)** al panel de piso interior.



6.5

- Insert **Bushings (AHO)** through the holes in the Floor. **The slit in the Bushing should face the front of the shed.**
- Insérer les **bagues (AHO)** à travers les trous dans le plancher. **La fente dans la bague doit donner sur le bord avant de l'abri.**
- Insertar los **casquillos (AHO)** a través de los agujeros en el piso. **La rendija en el casquillo debe dar hacia el borde delantero de la caseta.**

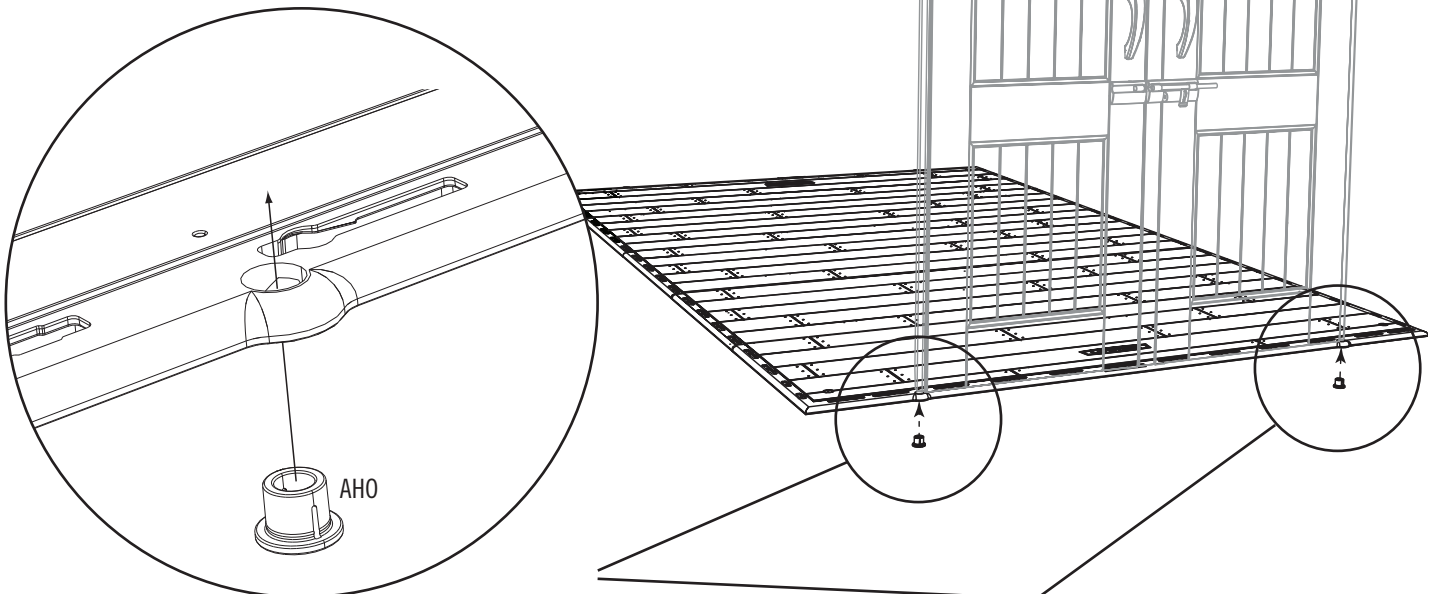

► SECTION 6 (CONTINUED) / SECTION 6 (SUITE) / SECCIÓN 6 (CONTINUACIÓN)

TOOLS AND HARDWARE REQUIRED / OUTILS ET QUINCAILLERIE REQUIS / INSTRUMENTAL Y HERRAJE REQUERIDOS

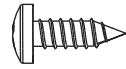

BQC (x16)

6.5



- Insert the **Screws (BQC)** through the divots in the Floor Panels and into the tabs of the adjacent Floor Panels. (The divots are near the seams of the Floor Panels.) **These Screws do not anchor the Floor; they only hold the Panels together.**
- Insérer les **vis (BQC)** à travers les marques dans les panneaux de plancher et dans les languettes du panneaux de plancher contigu. (Les marques se trouvent près des jonctions des panneaux de plancher.) **Ces vis n'ancrent pas le plancher ; ils ne servent que pour attacher les panneaux les uns aux autres.**
- Insertar los **tornillos (BQC)** a través de las marcas en los paneles de piso y dentro de las lengüetas des los paneles de piso adyacentes. (Se encuentran las marcas cerca de las juntas de los paneles de piso.) **Estos tornillos no anclan el piso; sirven sólo para sujetar los paneles los unos a los otros.**

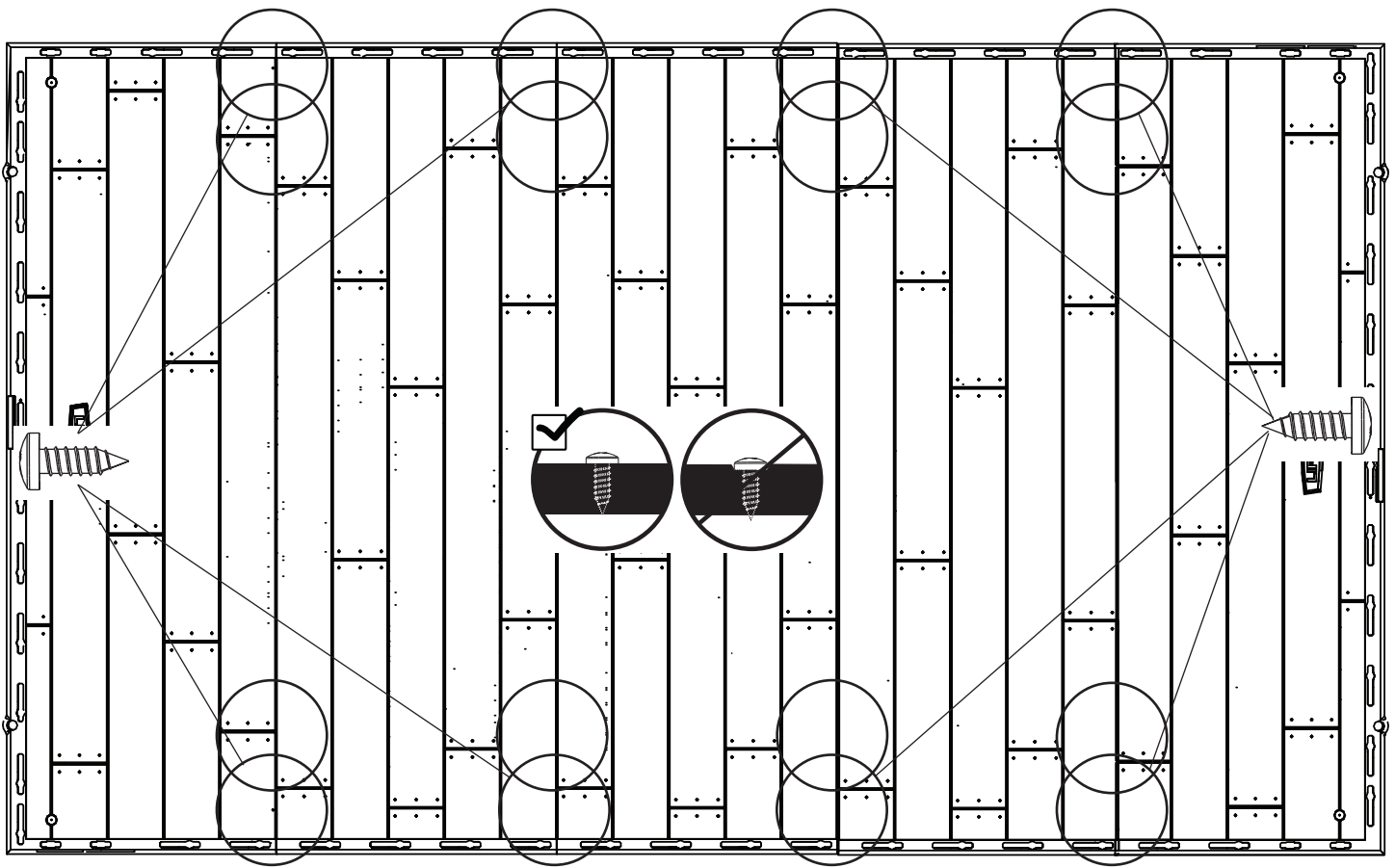

7

WALL ASSEMBLY / ASSEMBLAGE DES MURS / ENSAMBLE DE LOS MUROS



HARDWARE REQUIRED / QUINCAILLERIE REQUISE / HERRAJE REQUERIDO

Hardware Bag / Sac de quincaillerie / Bolsa de herraje

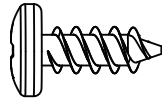
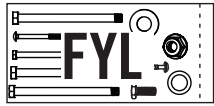

ADZ (x113)

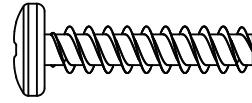

ADV (x6)



PARTS REQUIRED / PIÈCES REQUISES / PIEZAS REQUERIDAS

Metal Parts / Pièces en métal / Piezas de metal

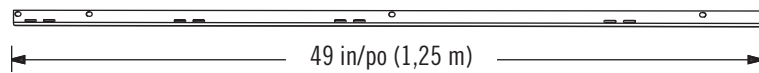

BXT (x2)

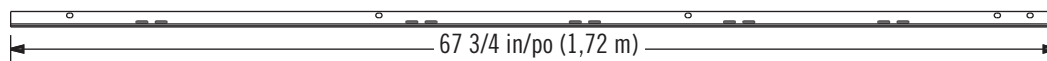
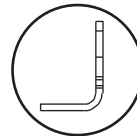

AFM (x8)

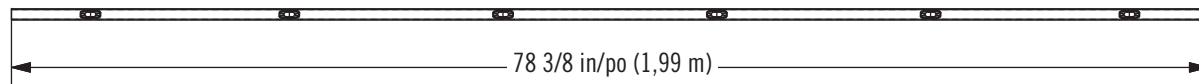
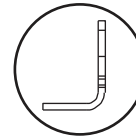

BXX (x1)

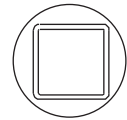

Plastic Parts / Pièces en plastique / Piezas de plástico

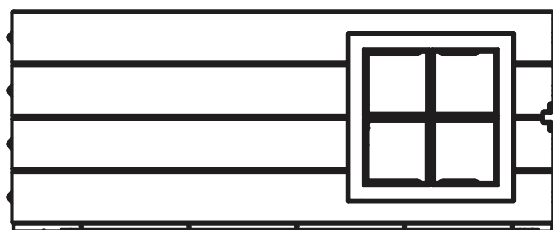

AHH (x2)



AHD (x8)

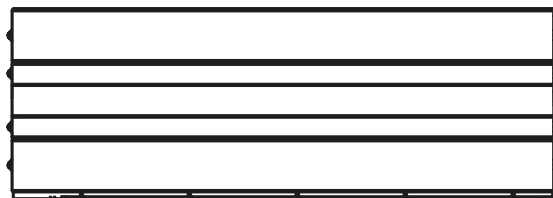

AGL (x4)



TOOLS REQUIRED / OUTILS REQUIS / INSTRUMENTAL REQUERIDO



EUF (x1)



► SECTION 7 (CONTINUED) / SECTION 7 (SUITE) / SECCIÓN 7 (CONTINUACIÓN)

TOOLS AND HARDWARE REQUIRED / OUTILS ET QUINCAILLERIE REQUIS / INSTRUMENTAL Y HERRAJE REQUERIDOS

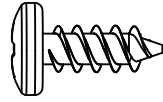

ADZ (x40)

7.1

- Attach a **Wall Support Channel (AFM)** to a **Wall Panel (AHD)** using five (5) **Screws (ADZ)**. Repeat this step for all Wall Panels.
- Fixer un **canal de support mural (AFM)** au **panneau mural (AHD)** à l'aide de cinq (5) **vis (ADZ)**. Répéter cette étape pour tous les panneaux muraux.
- Fijar un **canal de soporte mural (AFM)** al **panel mural (AHD)** usando cinco (5) **tornillos (ADZ)**. Repetir este paso para todos los paneles murales.

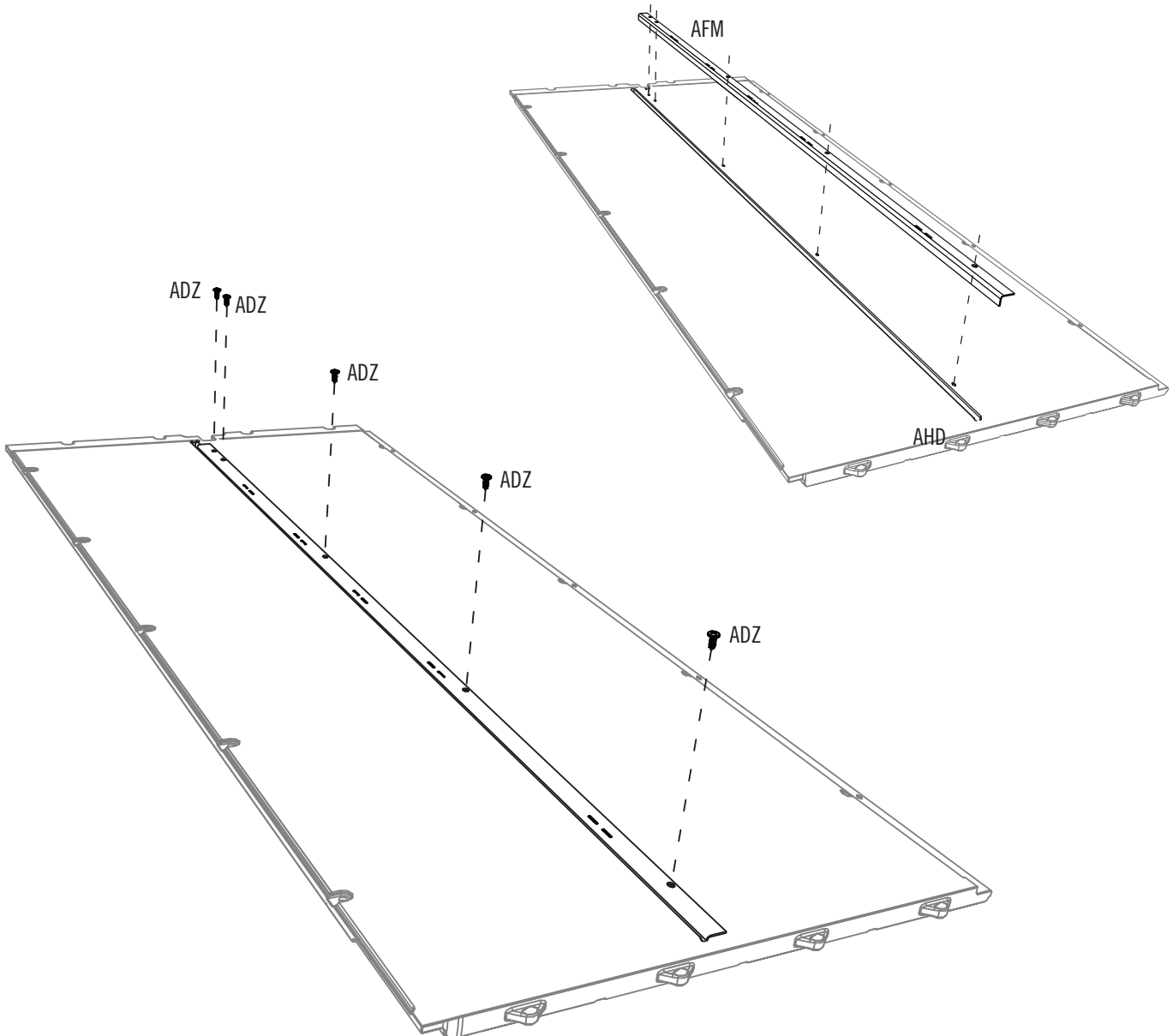

► SECTION 7 (CONTINUED) / SECTION 7 (SUITE) / SECCIÓN 7 (CONTINUACIÓN)

TOOLS AND HARDWARE REQUIRED / OUTILS ET QUINCAILLERIE REQUIS / INSTRUMENTAL Y HERRAJE REQUERIDOS

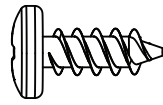

ADZ (x8)

7.2

- Attach a **Wall Support Channel (BXT)** to each **Window Wall Panel (AHH)** using four (4) **Screws (ADZ)**. Repeat this step for the **second Window Wall Panel**.
- Fixer un **canal de support mural (BXT)** à chaque **panneau mural pour la fenêtre (AHH)** à l'aide de quatre (4) **vis (ADZ)**. Répéter cette étape pour le deuxième panneau mural avec fenêtre.
- Fijar un **canal de soporte mural (BXT)** a cada **panel mural para la ventana (AHH)** usando cuatro (4) **tornillos (ADZ)**. Repetir este paso para el otro panel mural con ventana.

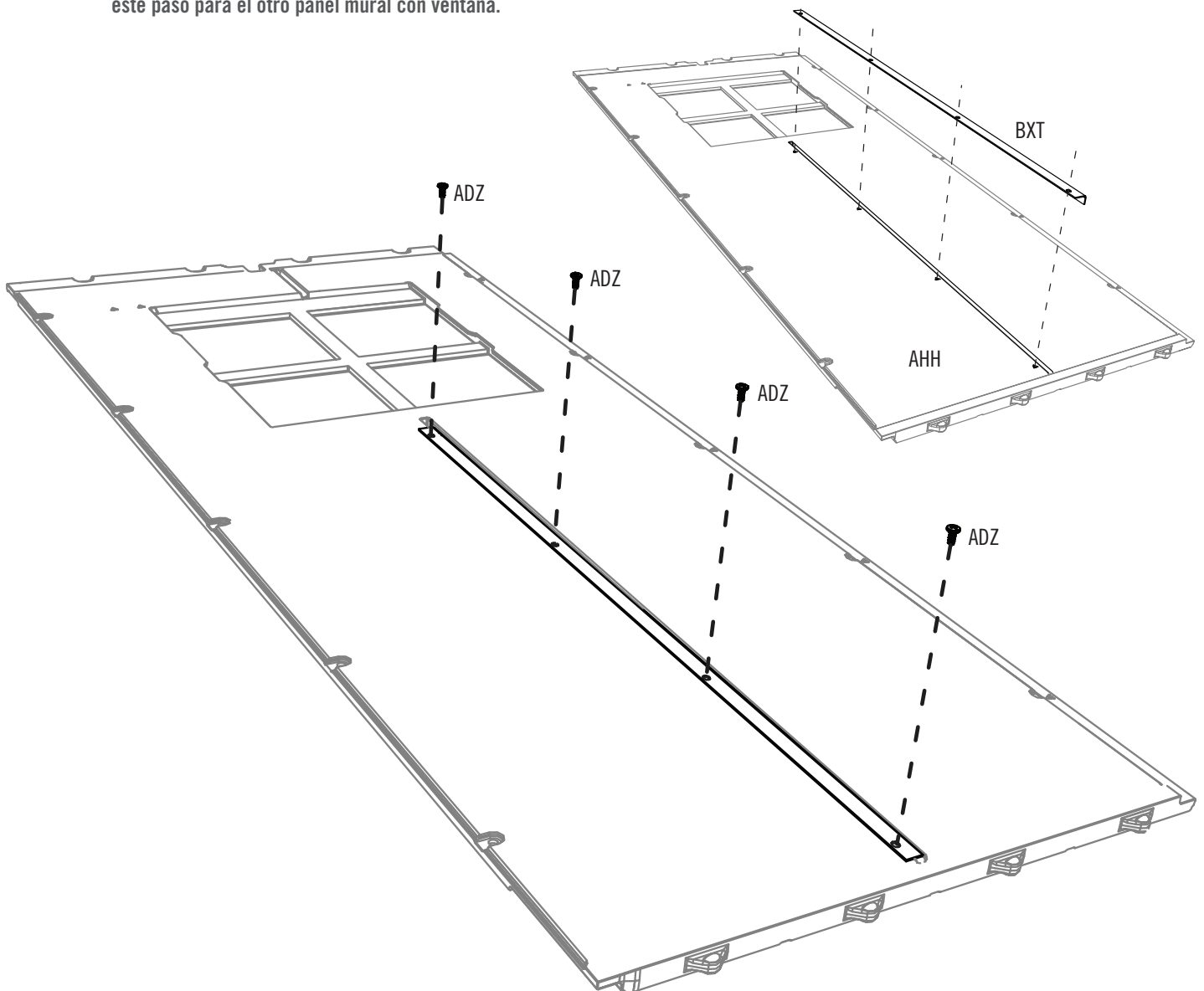

► SECTION 7 (CONTINUED) / SECTION 7 (SUITE) / SECCIÓN 7 (CONTINUACIÓN)

TOOLS AND HARDWARE REQUIRED / OUTILS ET QUINCAILLERIE REQUIS / INSTRUMENTAL Y HERRAJE REQUERIDOS



7.3

- Insert the two left-most tabs at the bottom of the **Corner Panel (AGL)** into the two right-most slots along the front edge of the Floor.
- Insérer les deux languettes gauches au bord inférieur du **panneau angulaire (AGL)** dans les deux rainures droites le long du bord avant du plancher.
- Insertar las lengüetas al borde inferior del **panel angular (AGL)** en las ranuras a lo largo del borde delantero del piso.

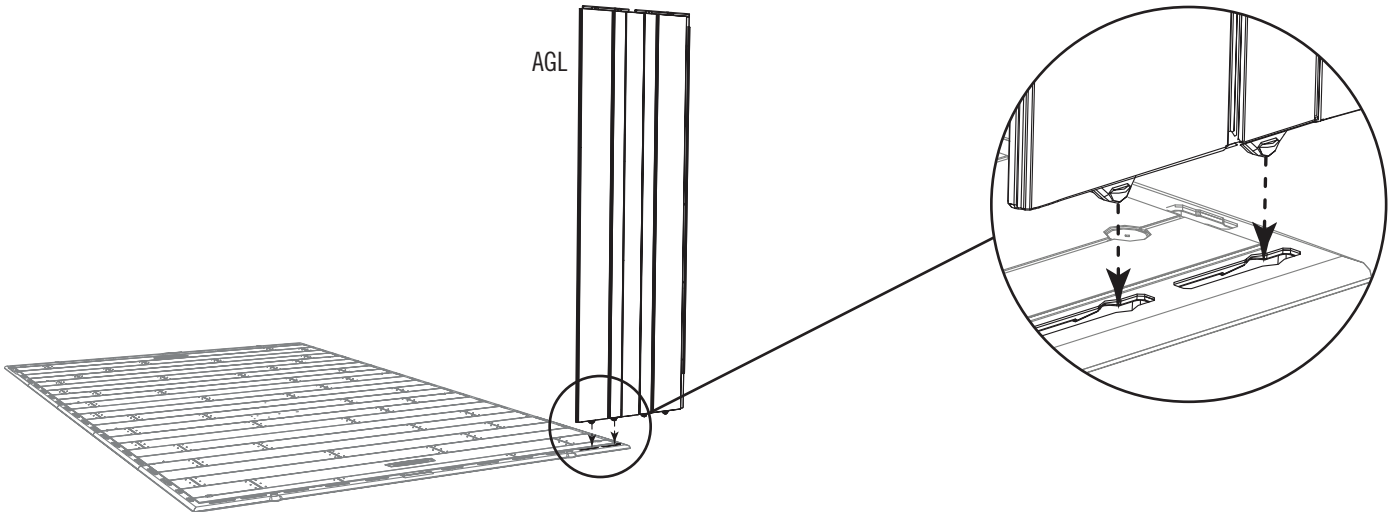

7.4

- Slide the Corner Panel to the left. Bend the Corner Panel.
- Faire glisser le panneau angulaire à la gauche. Pliez le panneau angulaire.
- Deslizar el panel angular a la izquierda. Doble el panel angular.

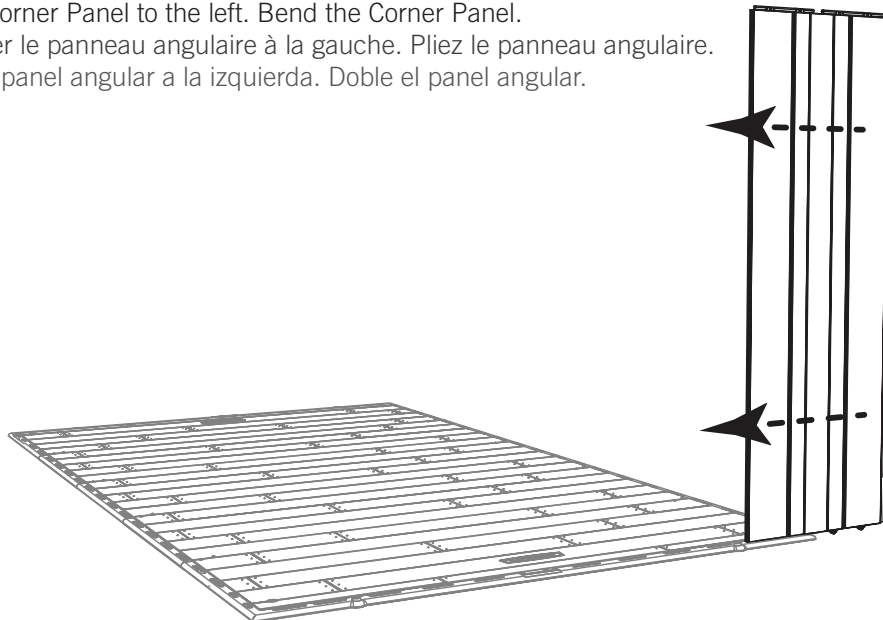

► SECTION 7 (CONTINUED) / SECTION 7 (SUITE) / SECCIÓN 7 (CONTINUACIÓN)

TOOLS AND HARDWARE REQUIRED / OUTILS ET QUINCAILLERIE REQUIS / INSTRUMENTAL Y HERRAJE REQUERIDOS

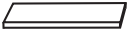

EUF (x1)



7.5

- Pull down on the Panel to insert the remaining tabs. To help with insertion, place the **Plastic Block (EUF)** under the Floor Panel directly under the tab being inserted. You should hear a “click” when the tab pops into place. **Repeat this step for the second tab.**
- Tirer le panneau pour insérer les languettes restantes. Pour aider avec l'assemblage, mettez le **bloque en plastique (EUF)** sous le panneau de plancher directement sous la languette que vous voudriez insérer. S'écoute un « dé clic » lorsque la languette s'emboîte en place. **Répéter ce processus pour la deuxième languette.**
- Tirar para abajo el panel para insertar las lengüetas restantes. Para ayudar con el ensamble, deslizar el **bloque de plástico (EUF)** debajo el panel de piso directamente debajo la lengüeta que quiere insertar. Se escuchará un « clic » cuando la lengüeta se encaja en su lugar. **Repetir este proceso para la segunda lengüeta.**

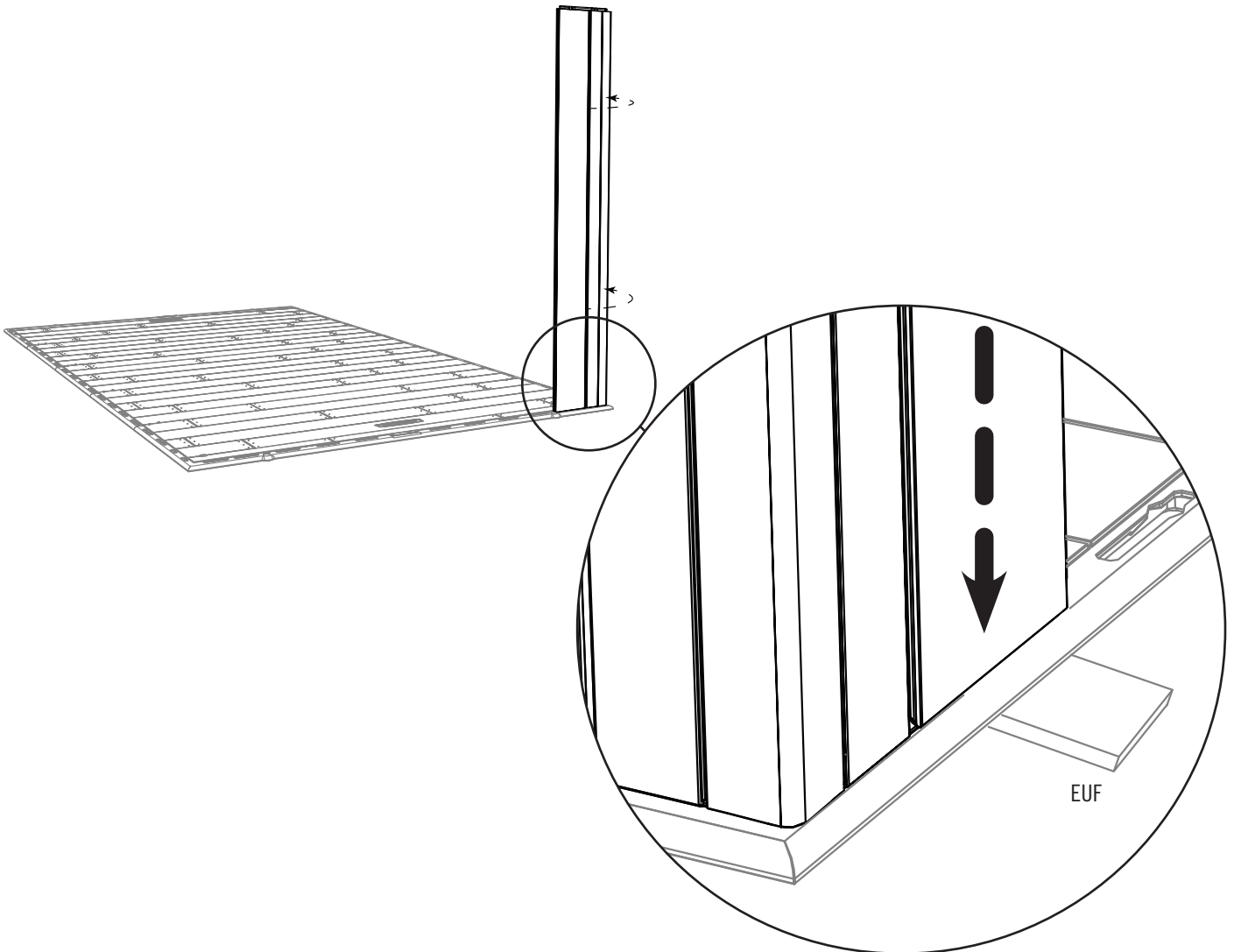

► SECTION 7 (CONTINUED) / SECTION 7 (SUITE) / SECCIÓN 7 (CONTINUACIÓN)

TOOLS AND HARDWARE REQUIRED / OUTILS ET QUINCAILLERIE REQUIS / INSTRUMENTAL Y HERRAJE REQUERIDOS

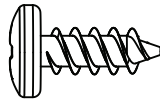

ADZ (x20)

7.6

• One at a time, insert the tabs of four (4) **Wall Panels (AHD & AHH)** into the slots along the right edge of the Floor. Slide the Panels toward the Corner Panel. Secure the Panels to one another using five (5) **Screws (ADZ)** for each seam. **The Window Wall Panel (AHH) can go at any side Wall Panel position.**

• Un par un, insérer les languettes des quatre (4) **panneaux muraux (AHD et AHH)** dans les fentes le long du bord droit du plancher. Faire glisser les panneaux vers le panneau angulaire. Fixer les panneaux les un aux autres à l'aide de cinq (5) **vis (ADZ)** chaque joint. **On peut installer le panneau mural à fenêtre (AHH) à n'importe quelle position latérale.**

• Uno por uno, insertar las lengüetas de cuatro (4) **paneles murales (AHD y AHH)** dentro de las ranuras a lo largo del borde derecho del piso. Deslizar los paneles hacia el panel angular. Fijar los paneles los unos a los otros usando cinco (5) **tornillos (ADZ)** para cada junta. **Se puede instalar el panel mural para ventana (AHH) a cualquier posición lateral.**

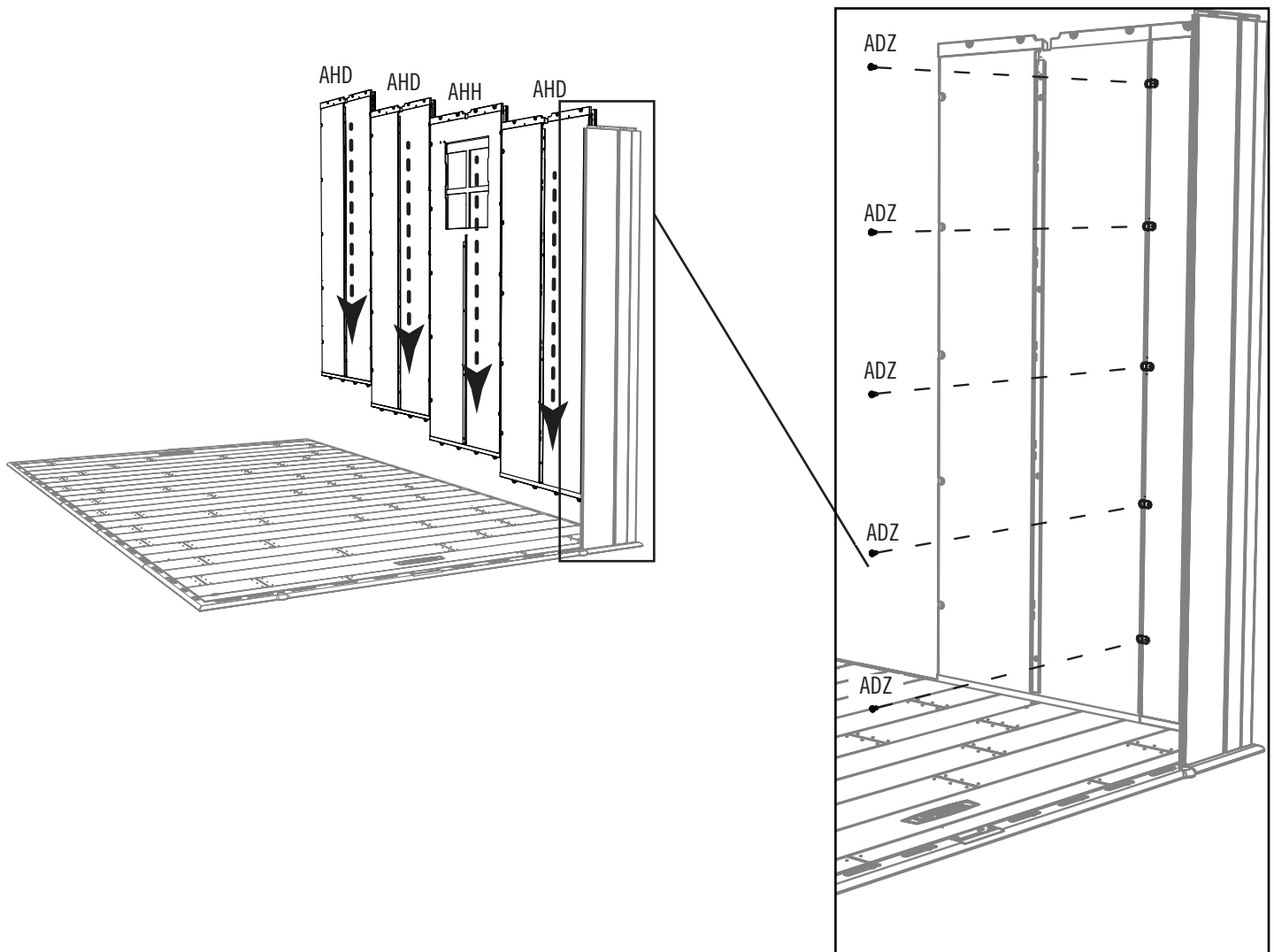

► SECTION 7 (CONTINUED) / SECTION 7 (SUITE) / SECCIÓN 7 (CONTINUACIÓN)

TOOLS AND HARDWARE REQUIRED / OUTILS ET QUINCAILLERIE REQUIS / INSTRUMENTAL Y HERRAJE REQUERIDOS

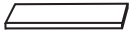

EUF (x1)

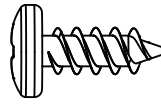

ADZ (x15)

7.7

- Attach this Corner Panel in the same manner you did the previous Corner Panel.
- Fixer ce panneau angulaire de la même façon que le panneau angulaire précédent.
- Fijar este panel angular de la misma manera que el panel angular anterior.

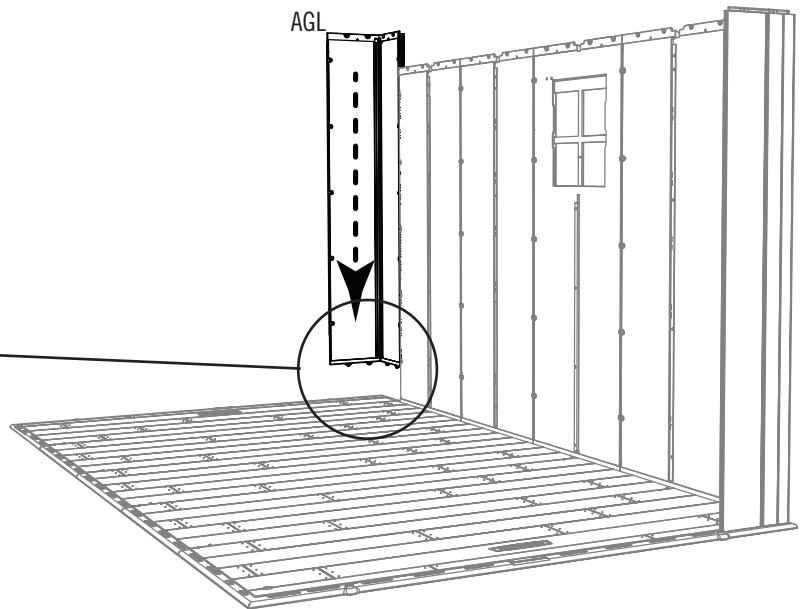
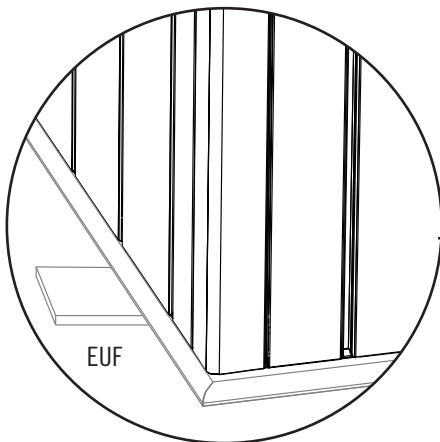

7.8

- Insert the tabs of two (2) **Wall Panels (AHD)** into the slots along the rear edge of the Floor. Slide the Panels toward the Corner Panel. Secure the Panels to one another using five (5) **Screws (ADZ)** for each Panel.
- Insérer les languettes des deux (2) **panneaux muraux (AHD)** dans les fentes le long du bord arrière du plancher. Faire glisser les panneaux vers le panneau angulaire. Fixer les panneaux les un aux autres à l'aide de cinq (5) **vis (ADZ)** pour chaque panneau.
- Insertar las lengüetas de dos (2) **paneles murales (AHD)** dentro de las ranuras a lo largo del borde trasero del piso. Deslizar los paneles hacia el panel angular. Fijar los paneles los unos a los otros usando cinco (5) **tornillos (ADZ)** para cada panel.

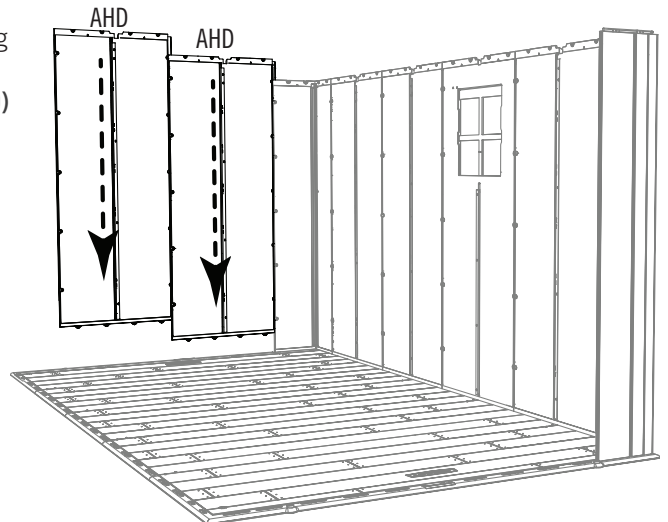

► SECTION 7 (CONTINUED) / SECTION 7 (SUITE) / SECCIÓN 7 (CONTINUACIÓN)

TOOLS AND HARDWARE REQUIRED / OUTILS ET QUINCAILLERIE REQUIS / INSTRUMENTAL Y HERRAJE REQUERIDOS

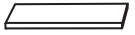

EUF (x1)

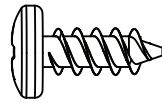

ADZ (x25)

7.9

- Secure this Corner Panel in the same manner you did the previous Corner Panel.
- Fixer ce panneau angulaire de la même façon que le panneau angulaire précédent.
- Fijar este panel angular de la misma manera que el panel angular anterior.

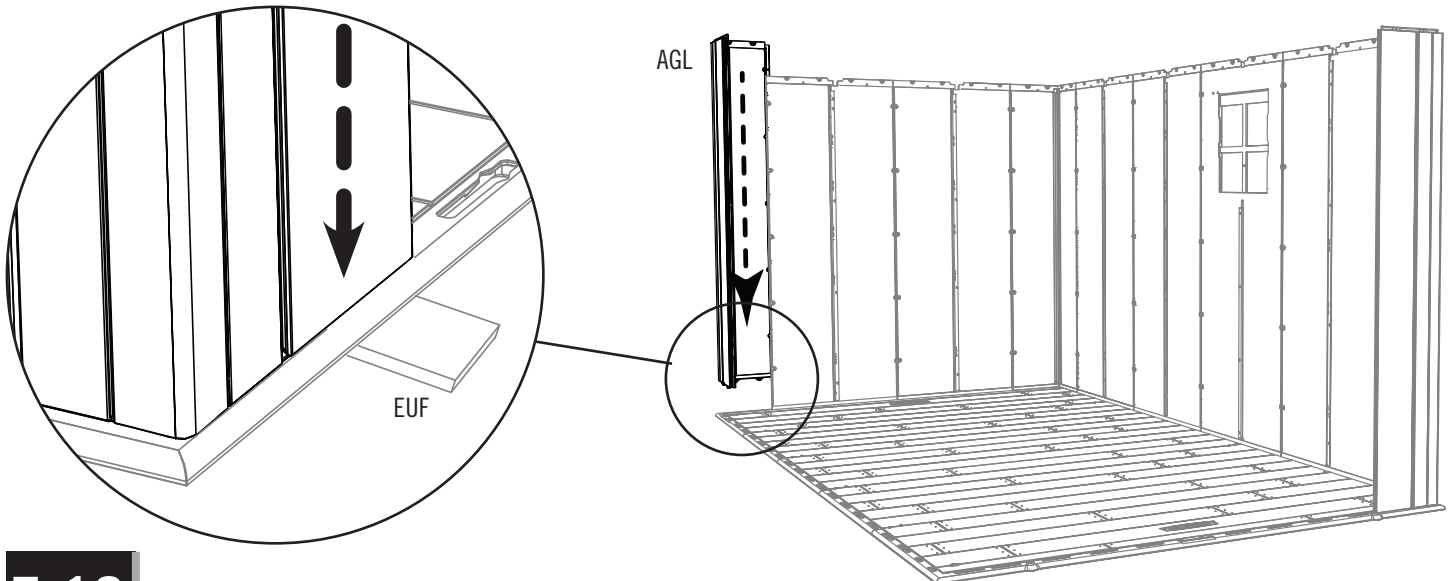

7.10

- Insert the tabs of four (4) **Wall Panels (AHH & AHD)** into the slots along the left edge of the Floor. Slide the Panels toward the Corner Panel. Secure the Panels to one another using five (5) **Screws (ADZ)** for each Panel.
- Insérer les languettes des quatre (4) **panneaux muraux (AHH et AHD)** dans les fentes le long du bord gauche du plancher. Faire glisser les panneaux vers le panneau angulaire. Fixer les panneaux les un aux autres à l'aide de cinq (5) **vis (ADZ)** pour chaque panneau.
- Insertar las lengüetas de cuatro (4) **paneles murales (AHH y AHD)** dentro de las ranuras a lo largo del borde izquierdo del piso. Deslizar los paneles hacia el panel angular. Fijar los paneles los unos a los otros usando cinco (5) **tornillos (ADZ)** para cada panel.

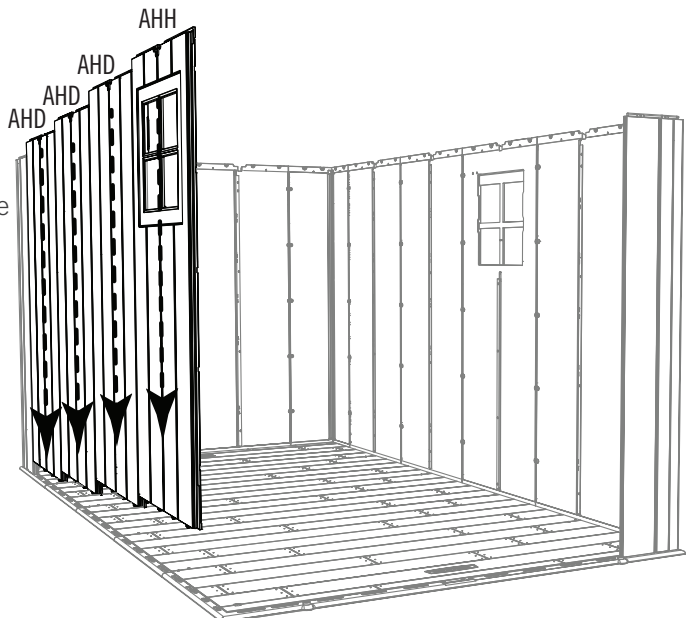

► SECTION 7 (CONTINUED) / SECTION 7 (SUITE) / SECCIÓN 7 (CONTINUACIÓN)

TOOLS AND HARDWARE REQUIRED / OUTILS ET QUINCAILLERIE REQUIS / INSTRUMENTAL Y HERRAJE REQUERIDOS

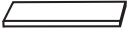

EUF (x1)

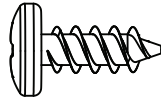
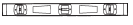

ADZ (x5)

7.11

- Secure this Corner Panel in the same manner you did the previous Corner Panel.
- Fixer ce panneau angulaire de la même façon que le panneau angulaire précédent.
- Fijar este panel angular de la misma manera que el panel angular anterior.

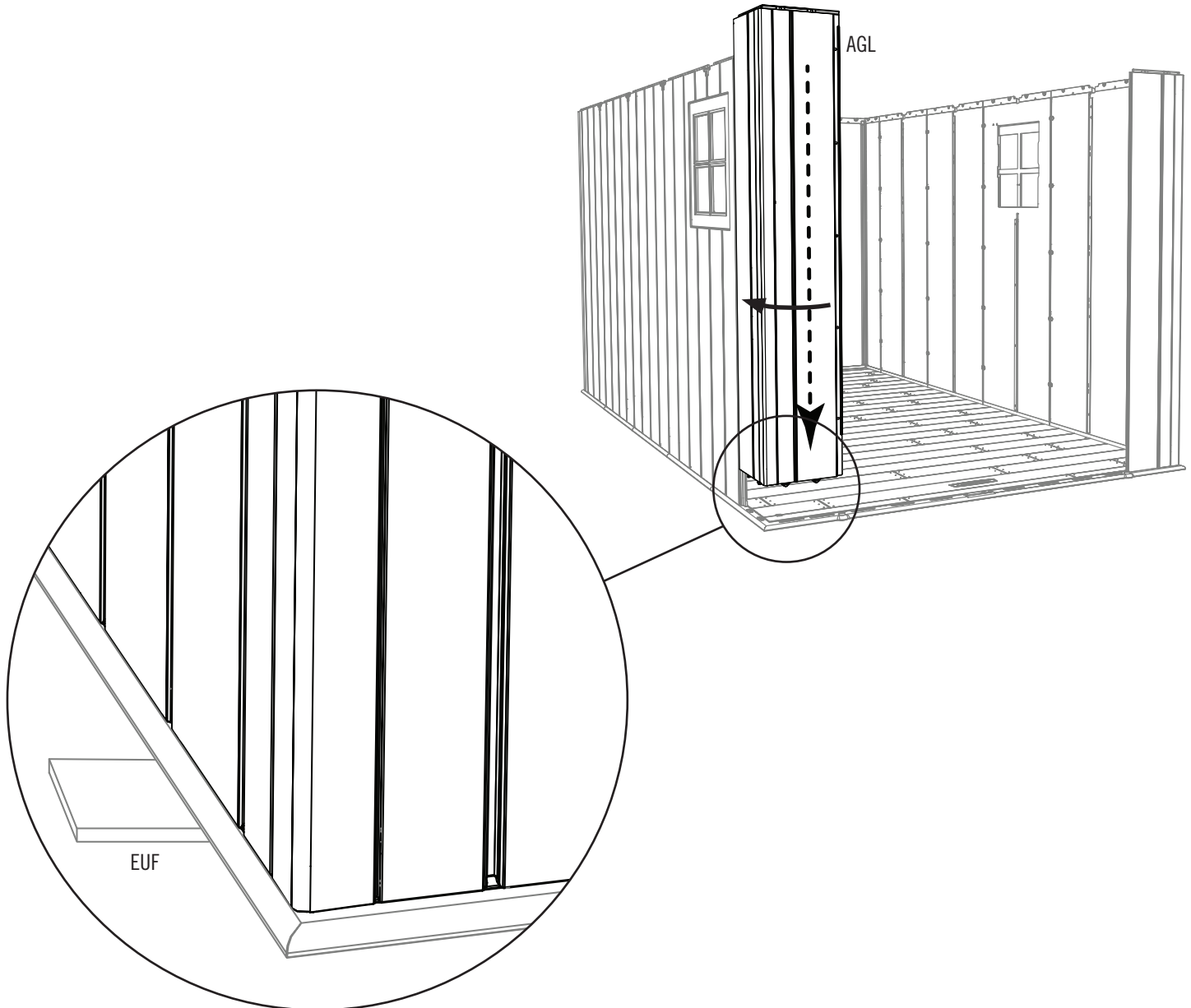

► SECTION 7 (CONTINUED) / SECTION 7 (SUITE) / SECCIÓN 7 (CONTINUACIÓN)

TOOLS AND HARDWARE REQUIRED / OUTILS ET QUINCAILLERIE REQUIS / INSTRUMENTAL Y HERRAJE REQUERIDOS

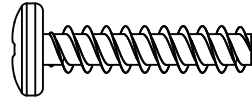

ADV (x6)

7.12

- Use a hand screwdriver to attach the **Wall Support Tube (BXX)** to the top of the rear Wall Panels using six (6) **Screws (ADV)**.
- Utiliser un tournevis manuel pour fixer le **tube de support mural (BXX)** au bord supérieur des panneaux muraux arrière à l'aide de six (6) **vis (ADV)**.
- Usar un destornillador manual para fijar el **tubo de soporte mural (BXX)** al borde superior de los paneles murales traseros usando seis (6) **tornillos (ADV)**.

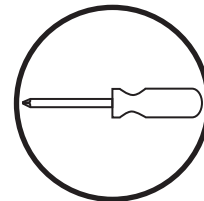
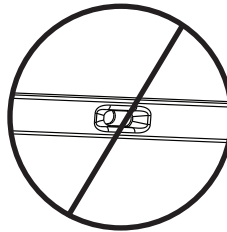
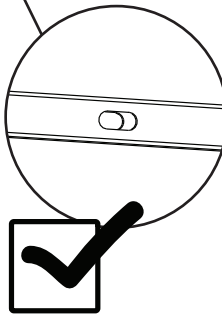
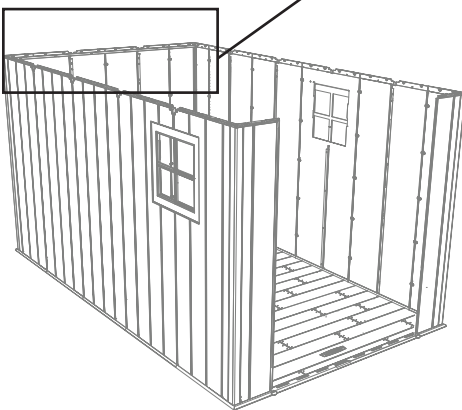
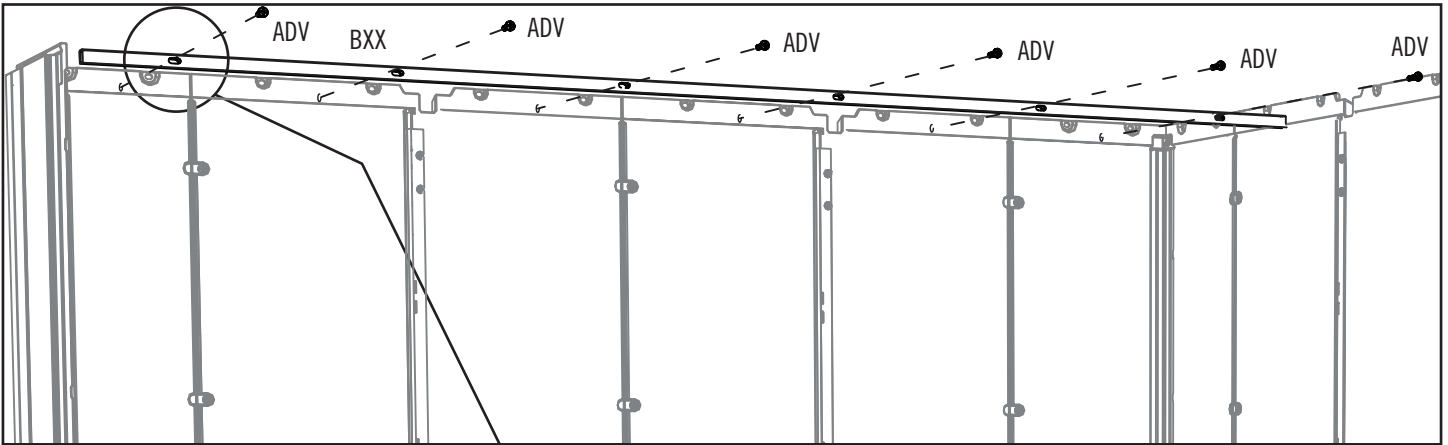

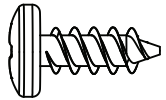
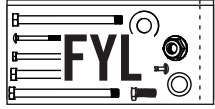

HARDWARE REQUIRED / QUINCAILLERIE REQUISE / HERRAJE REQUERIDO

Hardware Bag / Sac de quincaillerie / Bolsa de herraje

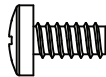

ADZ (x4)



ADY (x2)

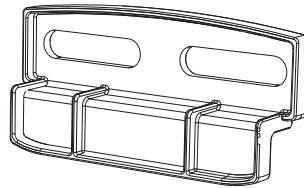

AIS (x2)

PARTS REQUIRED / PIÈCES REQUISES / PIEZAS REQUERIDAS

Plastic Parts / Pièces en plastique / Piezas de plástico

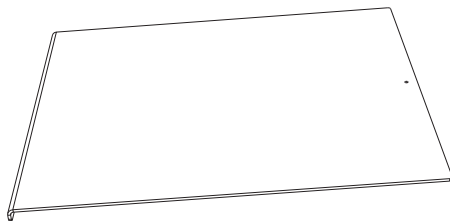

AHE (x2)

TOOLS REQUIRED / OUTILS REQUIS / INSTRUMENTAL REQUERIDO

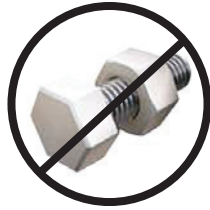

► SECTION 8 (CONTINUED) / SECTION 8 (SUITE) / SECCIÓN 8 (CONTINUACIÓN)

TOOLS AND HARDWARE REQUIRED / OUTILS ET QUINCAILLERIE REQUIS / INSTRUMENTAL Y HERRAJE REQUERIDOS

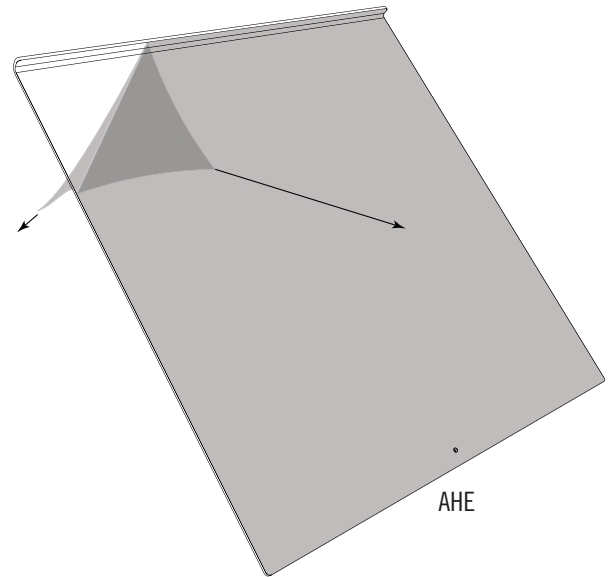

8.1

- Peel off the protective backing from both sides of the **Window Pane (AHE)**.
- Retirer la pellicule protectrice des deux côtés du **carreau (AHE)**.
- Retirar el protector de plástico de las dos caras de la **hoja de ventana (AHE)**.



8.2

- With the curved edge at the top and facing toward you, slide the Window Pane down into the opening.
- Avec le bord courbé vers le haut et à l'intérieur de l'abri, faire glisser le carreau en place.
- Con el borde curvo hacia arriba y hacia el interior de la caseta, deslizar la hoja en su lugar.

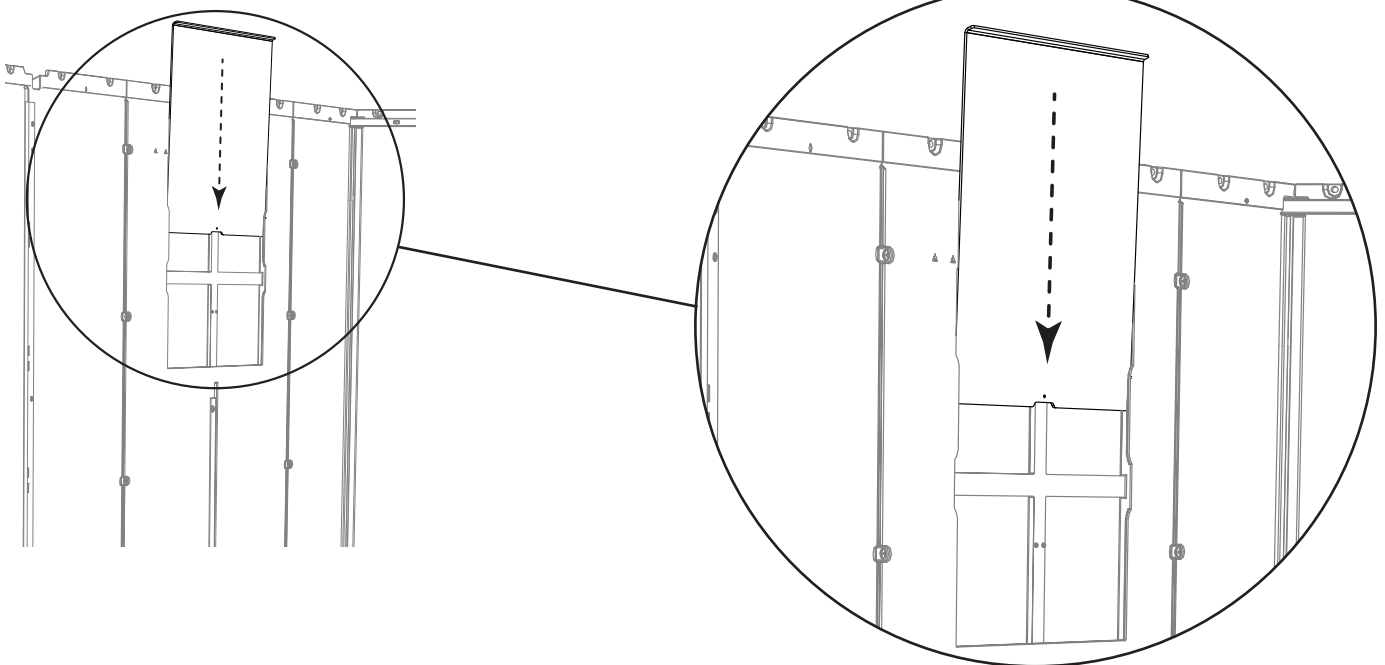

► SECTION 8 (CONTINUED) / SECTION 8 (SUITE) / SECCIÓN 8 (CONTINUACIÓN)

TOOLS AND HARDWARE REQUIRED / OUTILS ET QUINCAILLERIE REQUIS / INSTRUMENTAL Y HERRAJE REQUERIDOS

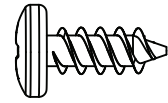

ADZ (x4)

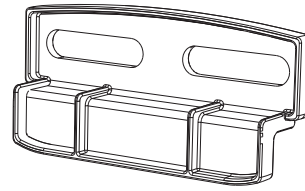

AIS (x2)

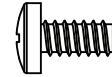

ADY (x2)

8.3

- Attach the **Latch (AIS)** at the top left corner of the Window. **The Latch should move freely.**
- Attachez le **loquet (AIS)** à l'angle supérieur gauche de la fenêtre. **Le loquet doit se déplacer librement.**
- Sujete el **cerrojo (AIS)** a la esquina izquierda superior de la ventana. **El cerrojo debe mover libremente.**

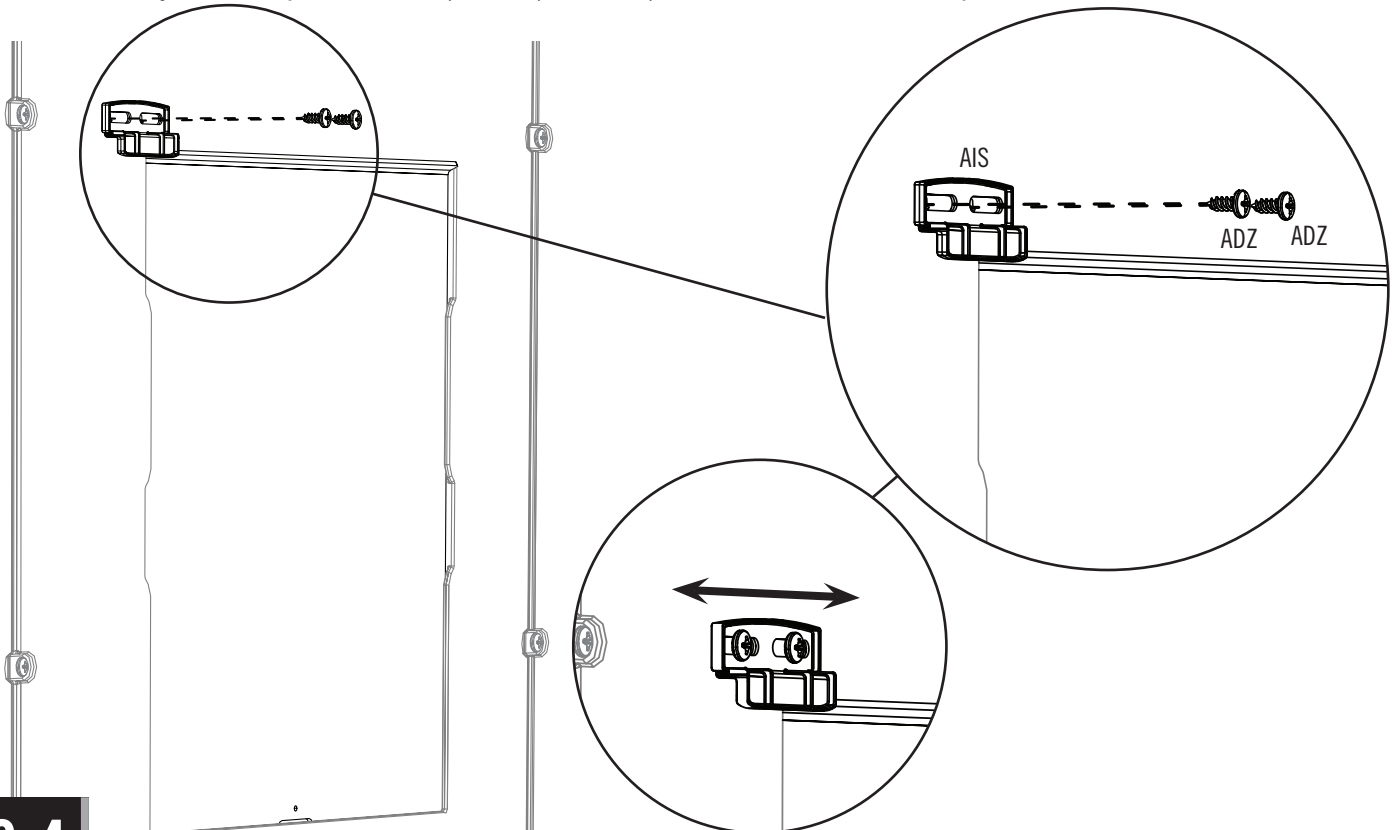

8.4

- Insert the **Screw (ADY)** into the hole at the bottom of the Window Pane. This helps keep the Window Pane up when open. **Repeat this section for the second Window Pane.**
- Insérer la **vis (ADY)** dans le trou au bord inférieur du carreau. Cela aide à maintenir le carreau en haut lorsqu'il est ouvert. **Répéter cette section pour le deuxième carreau.**
- Insertar el **tornillo (ADY)** en el agujero al borde inferior de la hoja. Esto ayuda a prevenir la cierre de la hoja. **Repetir esta sección para la segunda hoja.**

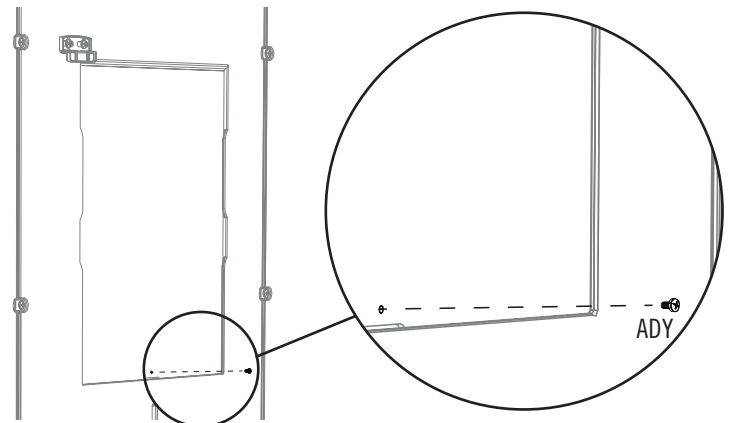

9

DOOR & ENTRY GABLE INSTALLATION / INSTALLATION DES PORTES ET DU PIGNON D'ENTRÉE / INSTALACIÓN DE LAS PUERTAS Y LA FACHADA DE ENTRADA



HARDWARE REQUIRED / QUINCAILLERIE REQUISE / HERRAJE REQUERIDO

Hardware Bag / Sac de quincaillerie / Bolsa de herraje

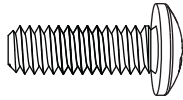

BFY (x5)

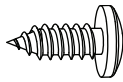

ADX (x2)



AHP (x2)



ADJ (x5)

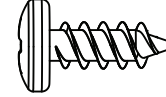

ADZ (x11)

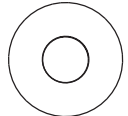

BXZ (x16)



BYM (x1)



PARTS REQUIRED / PIÈCES REQUISES / PIEZAS REQUERIDAS

Metal Parts / Pièces en métal / Piezas de metal

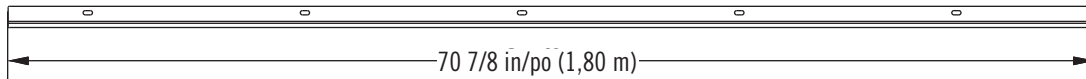

BYA (x1)

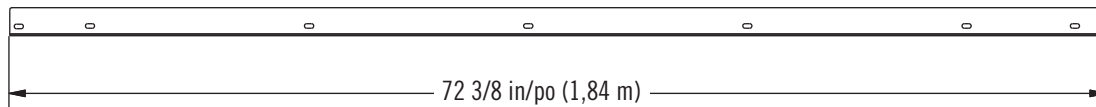
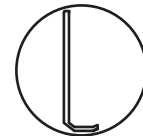

BYB (x1)

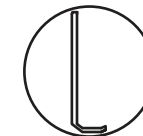

Plastic Parts / Pièces en plastique / Piezas de plástico



AGO (x1)

AGF (x1)

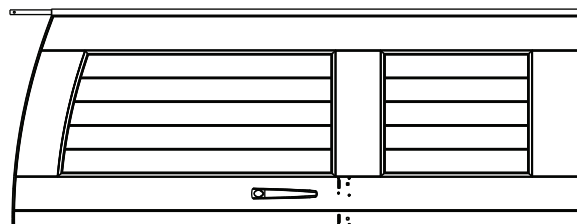

AGZ (x1)



TOOLS REQUIRED / OUTILS REQUIS / INSTRUMENTAL REQUERIDO



7/16 in/po (11 mm)



► SECTION 9 (CONTINUED) / SECTION 9 (SUITE) / SECCIÓN 9 (CONTINUACIÓN)

TOOLS AND HARDWARE REQUIRED / OUTILS ET QUINCAILLERIE REQUIS / INSTRUMENTAL Y HERRAJE REQUERIDOS

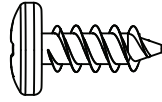

ADZ (x6)

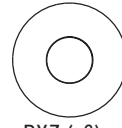

BXZ (x6)

9.1

- Place the **Right Door Jamb (BYB)**, the wider of the two Jamb, onto the edge of the right, front Corner Wall Panel. The Curved end curves toward the inside of the shed. Align the holes in the Jamb with those in the Corner Wall Panel. Secure the Jamb to the Panel using six (6) **Screws (ADZ)**. **The top hole does not require a Screw—yet.**
- Mettre le **montant droit (BYB)**, le plus large des deux montants, sur le bord du panneau angulaire droit avant. Le bord recourbé du montant courbe vers l'intérieur de l'abri. Aligner les trous dans le montant avec ceux du panneau angulaire. Fixer bien le montant au panneau à l'aide de six (6) **vis (ADZ)**. **Le trou supérieur n'exige pas encore d'une vis.**
- Colocar la **jamba derecha (BYB)**, la más ancha de las dos jambas, en el borde del panel angular derecho delantero. El borde curvado va hacia el interior de la caseta. Alinear los agujeros en la jamba con ellos en el panel angular. Fijar la jamba al panel usando seis (6) **tornillos (ADZ)**. **El agujero superior no requiere un tornillo todavía.**

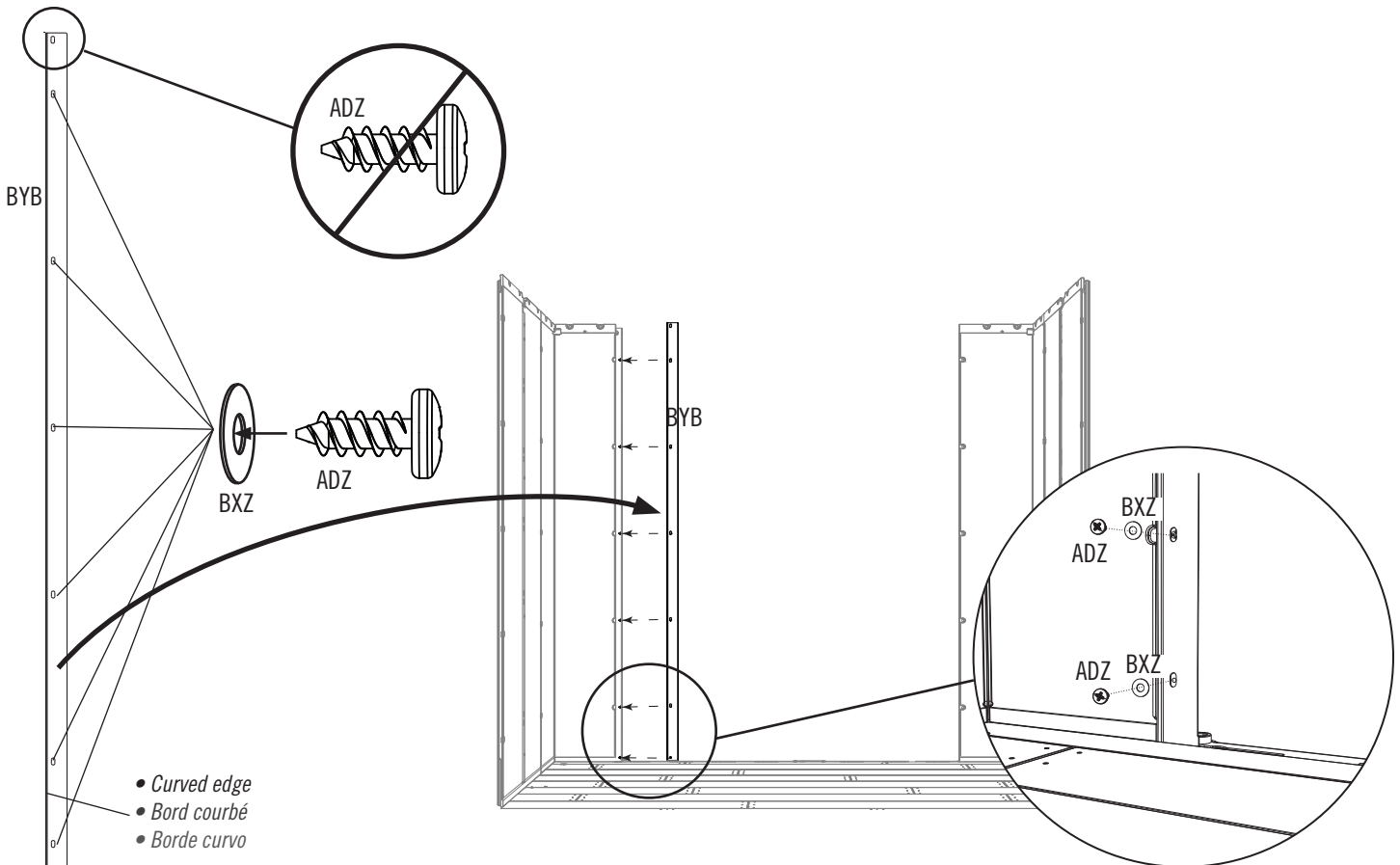

► SECTION 9 (CONTINUED) / SECTION 9 (SUITE) / SECCIÓN 9 (CONTINUACIÓN)

TOOLS AND HARDWARE REQUIRED / OUTILS ET QUINCAILLERIE REQUIS / INSTRUMENTAL Y HERRAJE REQUERIDOS



7/16 in/po
(11 mm)

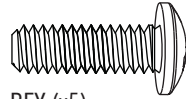

BFY (x5)

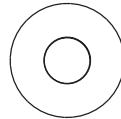

BXZ (x10)



ADJ (x5)

9.2

- Place the **Left Door Jamb (BYA)** onto the edge of the left, front Corner Wall Panel. The Curved edge curves toward the outside of the shed. Align the holes in the Jamb with those in the Corner Wall Panel. Secure the Jamb to the Panel using the hardware included.
- Mettre le **montant gauche (BYA)** sur le bord du panneau angulaire gauche avant. Le bord recourbé du montant courbe vers l'extérieur de l'abri. Aligner les trous dans le montant avec ceux du panneau angulaire. Fixer bien le montant au panneau à l'aide de la quincaillerie incluse.
- Colocar la **jamba izquierda (BYA)** en el borde del panel angular izquierdo delantero. El borde curvado va hacia el exterior de la caseta. Alinear los agujeros en la jamba con ellos en panel angular. Fijar la jamba al panel usando el herraje incluido.

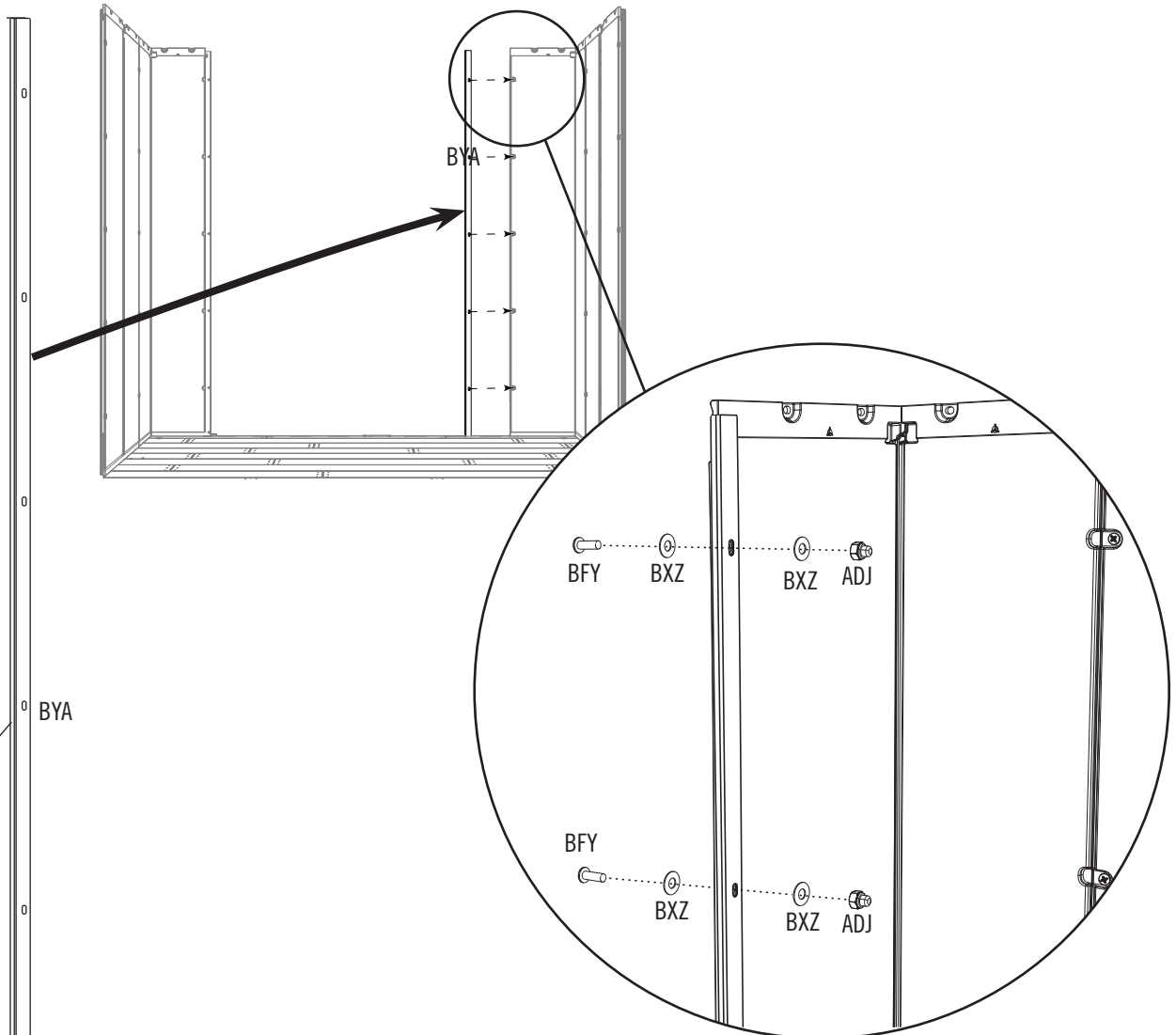

- Curved edge
- Bord courbé
- Borde curvo

► SECTION 9 (CONTINUED) / SECTION 9 (SUITE) / SECCIÓN 9 (CONTINUACIÓN)

TOOLS AND HARDWARE REQUIRED / OUTILS ET QUINCAILLERIE REQUIS / INSTRUMENTAL Y HERRAJE REQUERIDOS



AHP (x2)

9.3



• Pull the Hinge Tube down out of the Door about six inches. Align the hole at the bottom of the Hinge Tube with the slit in the Bushing, and insert the Tube. Insert a **Cotter Pin (AHP)** and bend the ends. **Repeat this step for the Right Door.**

• Tirer le tube d'articulation à peu près quinze centimètres du bord inférieur de la porte. Aligner le trou dans la partie inférieure du tube avec la fente dans la bague, et insérer le tube. Insérer une **clavette (AHP)** et plier les extrémités. **Répéter cette étape pour la porte droite.**

• Extender el tubo de articulación unos quince centímetros del borde inferior de la puerta. Alinear el agujero en la parte inferior del tubo con la rendija en el casquillo, e insertar el tubo. Insertar una **clavija (AHP)** y doble los extremos. **Repetir este paso para la puerta derecha.**

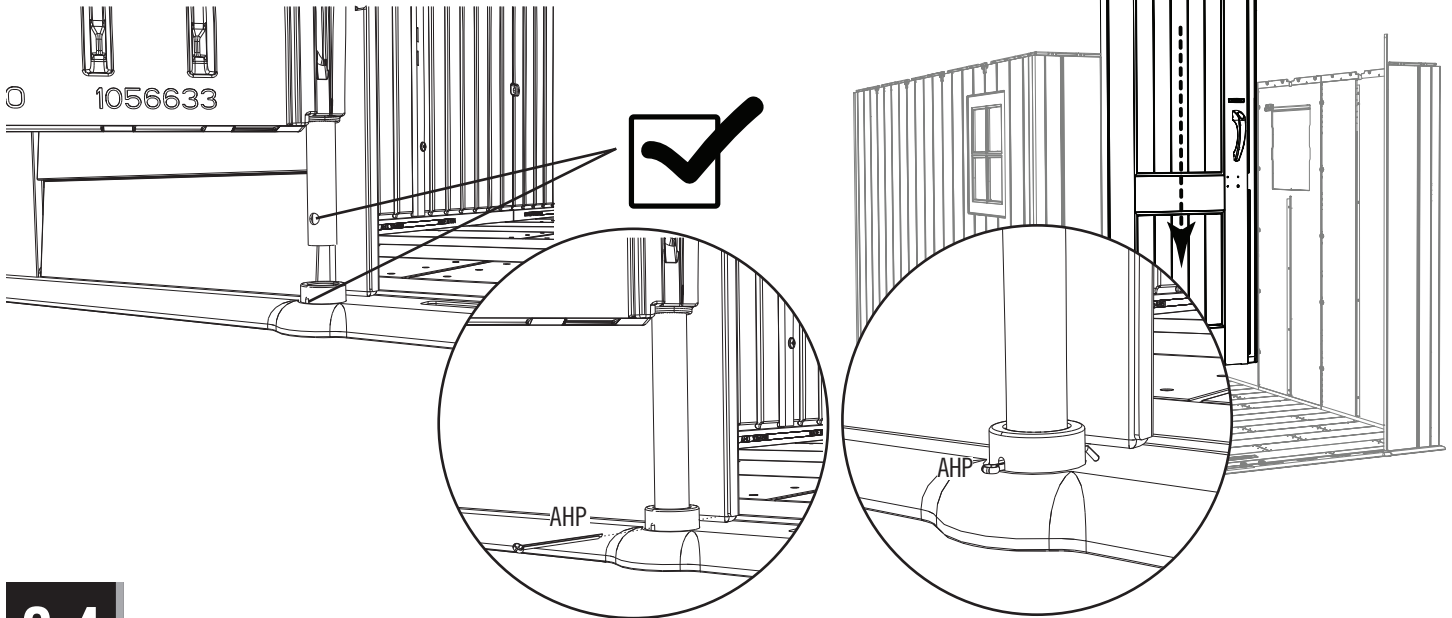

9.4

• While one adult holds the Left Door in place, repeat the last step for the Right Door.

• Pendant qu'un adulte maintient la porte gauche en place, répéter l'étape précédente pour la porte droite.

• Mientras que un adulto mantiene la puerta izquierda en su lugar, repetir el paso anterior para la puerta derecha.

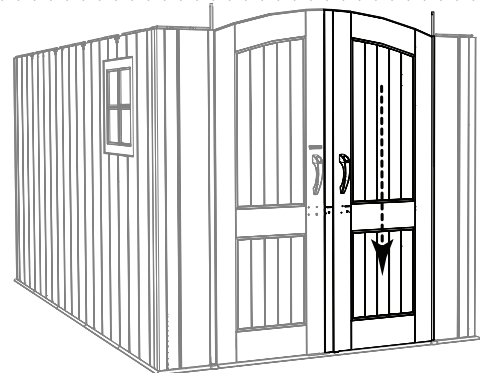

► SECTION 9 (CONTINUED) / SECTION 9 (SUITE) / SECCIÓN 9 (CONTINUACIÓN)

TOOLS AND HARDWARE REQUIRED / OUTILS ET QUINCAILLERIE REQUIS / INSTRUMENTAL Y HERRAJE REQUERIDOS

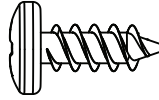

ADZ (x5)

9.5



- Slide the holes in the Entry Gable down over the two Hinge Tubes.
- Faire glisser les trous dans le pignon d'entrée sur les deux tubes.
- Deslizar los agujeros en la fachada de entrada sobre los dos tubos.

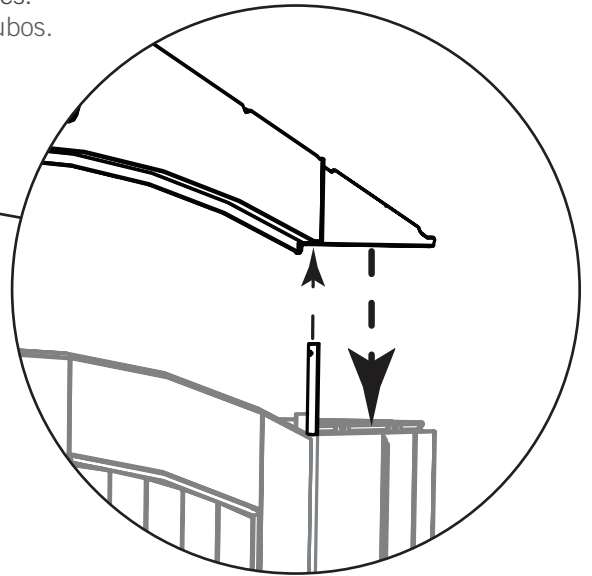
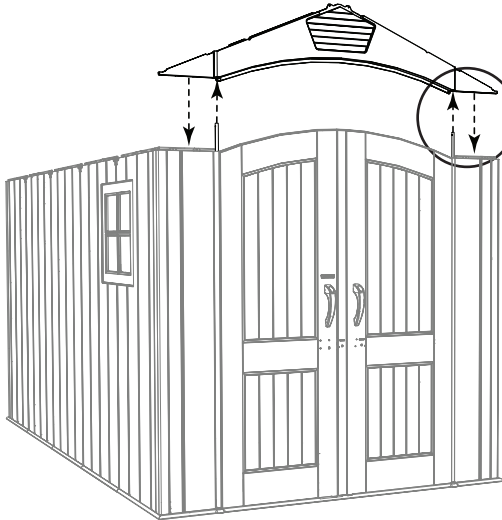

9.6

- Secure the Entry Gable to the Shed using five (5) **Screws (ADZ)**.
- Attacher le pignon d'entrée à l'abri à l'aide de cinq (5) **vis (ADZ)**.
- Sujetar la fachada de entrada a la caseta usando cinco (5) **tornillos (ADZ)**.

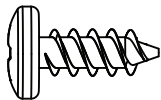

ADZ (x5)

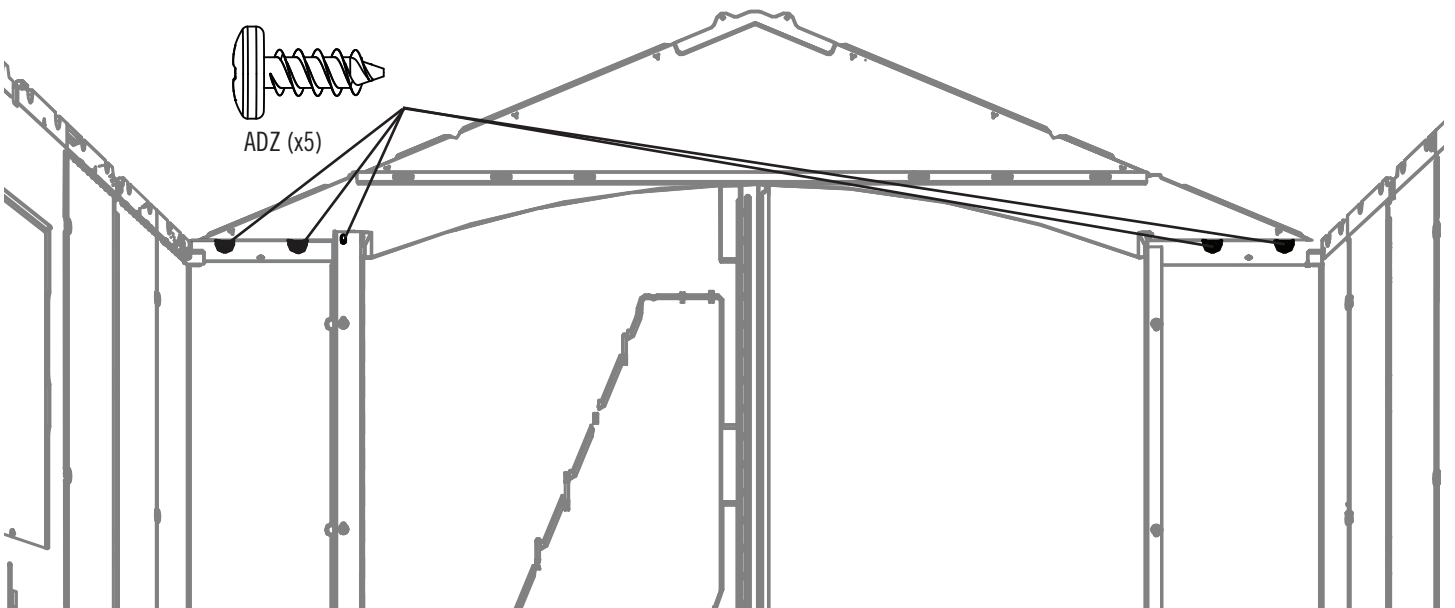



PARTS IDENTIFIER / IDENTIFICATEUR DE PIÈCES / IDENTIFICADOR DE PIEZAS

CONTENTS OF BOX 1 / CONTENU DE LA BOÎTE 1 / CONTENIDO DE LA CAJA 1

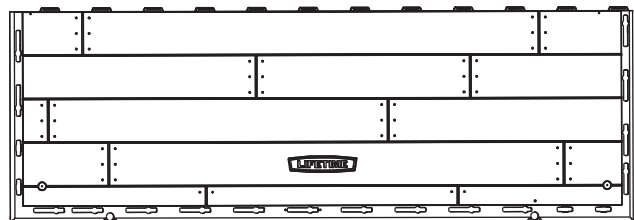

AGR (x2)

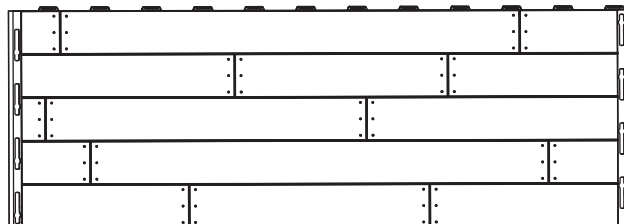

AFX (x3)

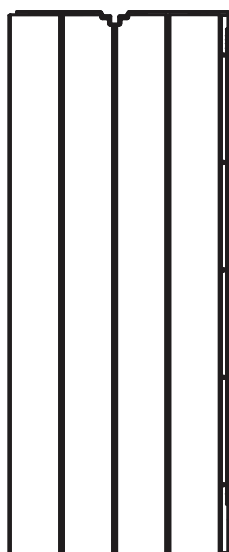

AHD (x4)

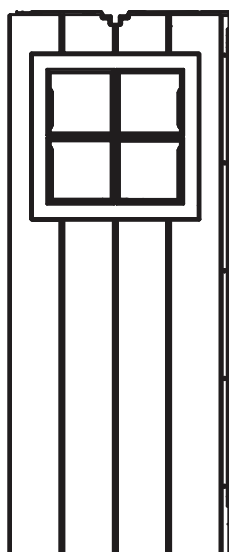

AHH (x2)

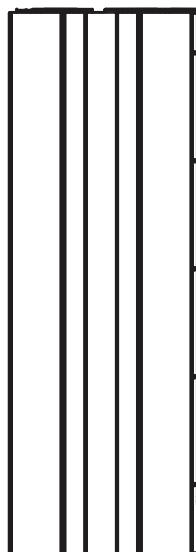

AGL (x1)

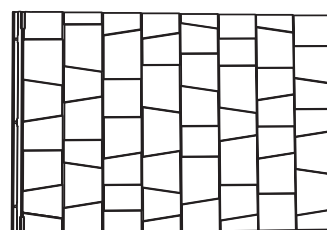

AGQ (x6)



AHE (x2)

CONTENTS OF SMALL PARTS BOX / CONTENU DE LA BOÎTE DE PETITES PIÈCES / CONTENIDO DE LA CAJA DE PIEZAS PEQUEÑAS

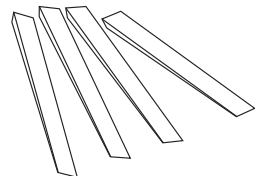

EUG (x4)

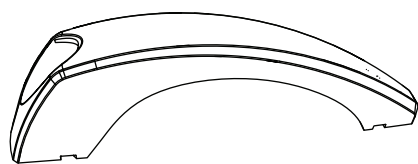

BYS (x2)

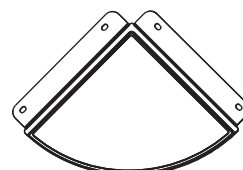

AFZ (x2)

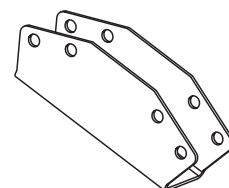

ETD (x4)



AIY (x2)

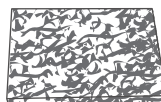

BYX (x4)

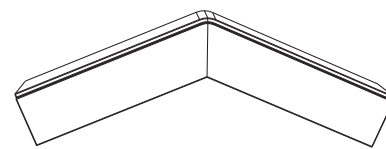

BYW (x2)



BYR (x2)



EUF (x1)

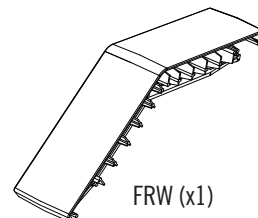

FRW (x1)

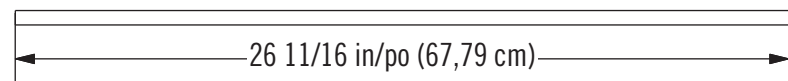

BYY (x10)

Remove This Section / Enlevez cette section / Retire esta sección



PARTS IDENTIFIER / IDENTIFICATEUR DE PIÈCES / IDENTIFICADOR DE PIEZAS

BLISTER PACKS / BLISTERS / BLÍSTERES

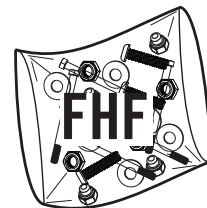
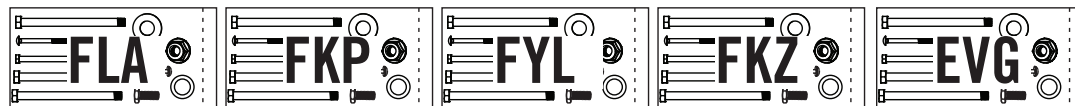

CONTENTS OF BOX 2 / CONTENU DE LA BÔÎTE 2 / CONTENIDO DE LA CAJA 2

Remove This Section / Enlevez cette section / Retire esta sección

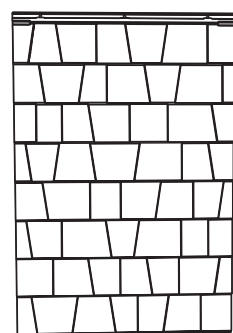

AGQ (x4)

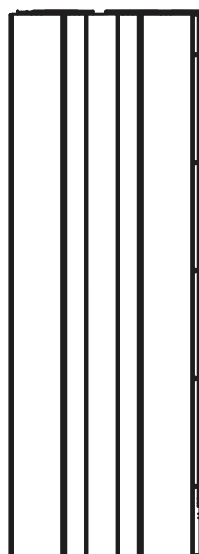

AGL (x3)

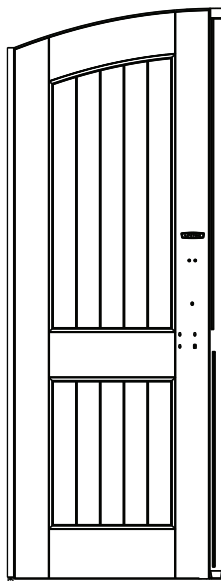

AGO (x1)

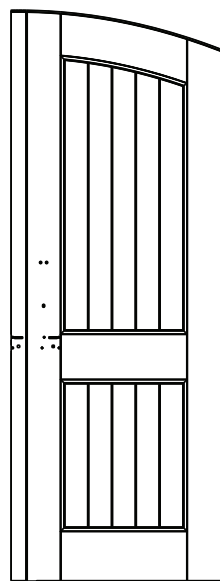

AGZ (x1)

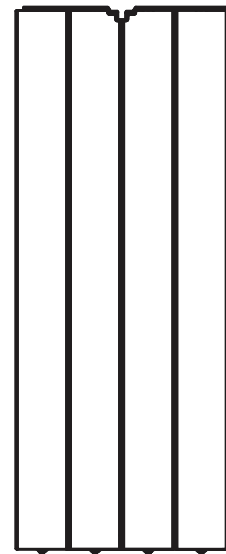

AHD (x4)

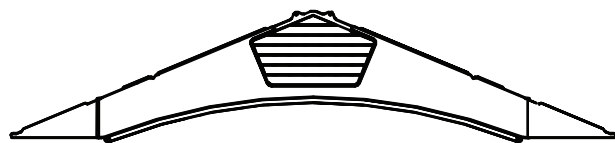

AGF (x1)

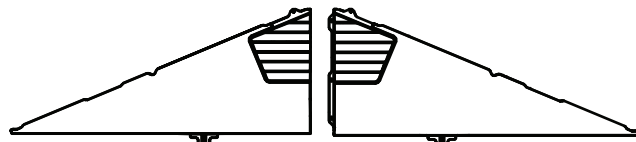

AGI (x1)

AGH (x1)

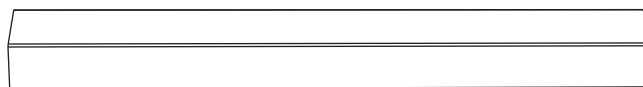

BYV (x1)

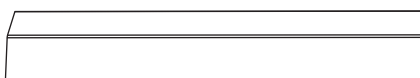

FYV (x1)



AFS (x1)



PARTS IDENTIFIER / IDENTIFICATEUR DE PIÈCES / IDENTIFICADOR DE PIEZAS

CONTENTS METAL KIT 1 / CONTENU DU KIT DE PIÈCES EN MÉTAL 1 / CONTENIDO DEL KIT DE PIEZAS DE METAL 1

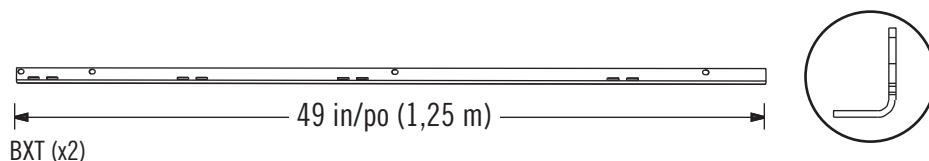
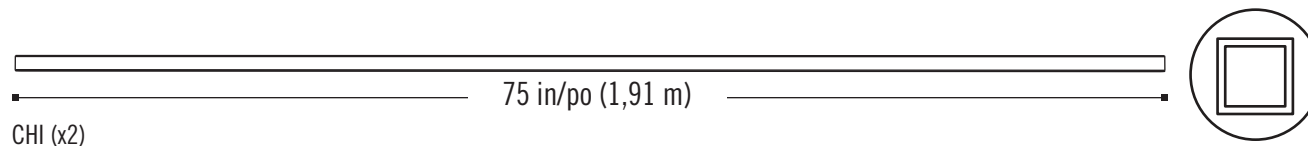
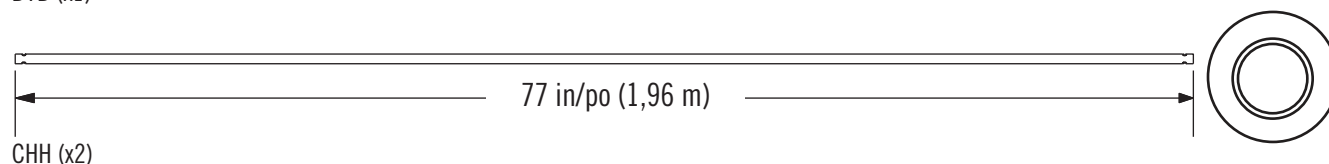
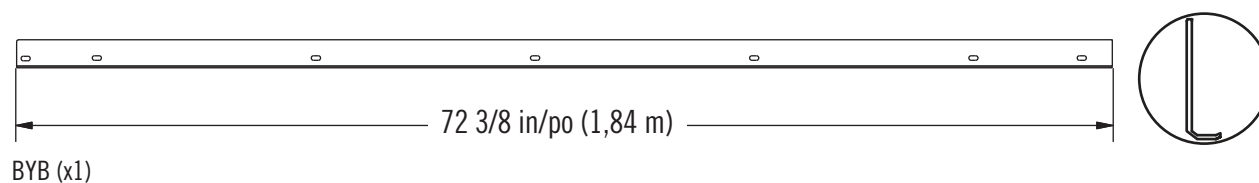
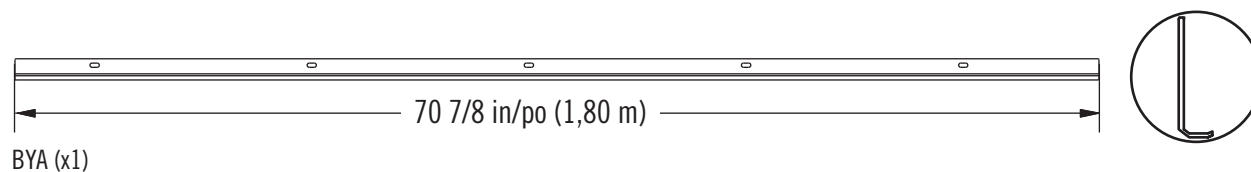
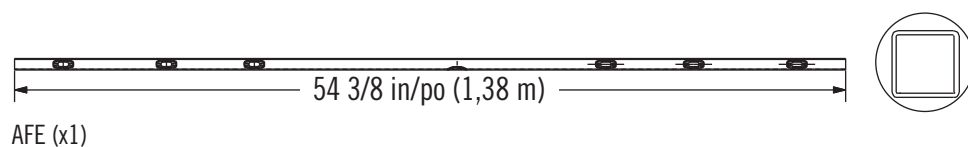
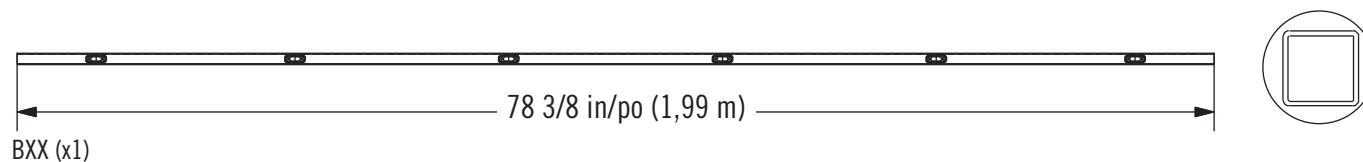
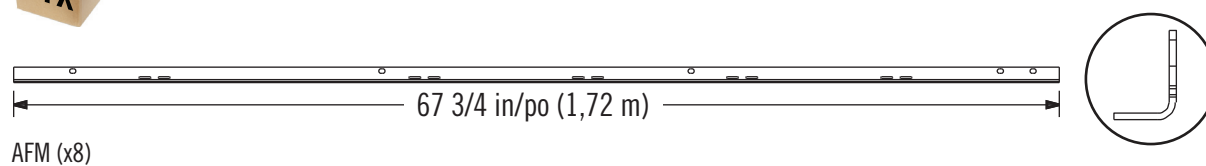

Remove This Section / Enlevez cette section / Retire esta sección



PARTS IDENTIFIER / IDENTIFICATEUR DE PIÈCES / IDENTIFICADOR DE PIEZAS

CONTENTS METAL KIT 2 / CONTENU DU KIT DE PIÈCES EN MÉTAL 2 / CONTENIDO DEL KIT DE PIEZAS DE METAL 2

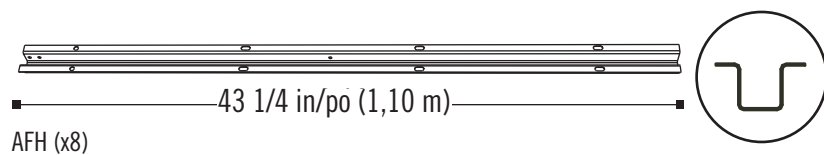
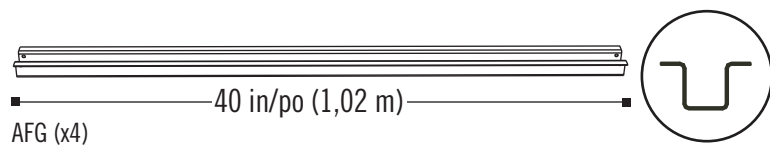

Remove This Section / Enlevez cette section / Retire esta sección

► SECTION 9 (CONTINUED) / SECTION 9 (SUITE) / SECCIÓN 9 (CONTINUACIÓN)

TOOLS AND HARDWARE REQUIRED / OUTILS ET QUINCAILLERIE REQUIS / INSTRUMENTAL Y HERRAJE REQUERIDOS

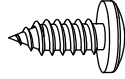

ADX (x2)



BYM (x1)

9.7

- Attach the **strike Plate (BYM)** to the floor as shown.
- Attacher la **plaque de verrouillage (BYM)** au plancher comme illustré.
- Sujetar la **placa de cierre (BYM)** al piso como se muestra.

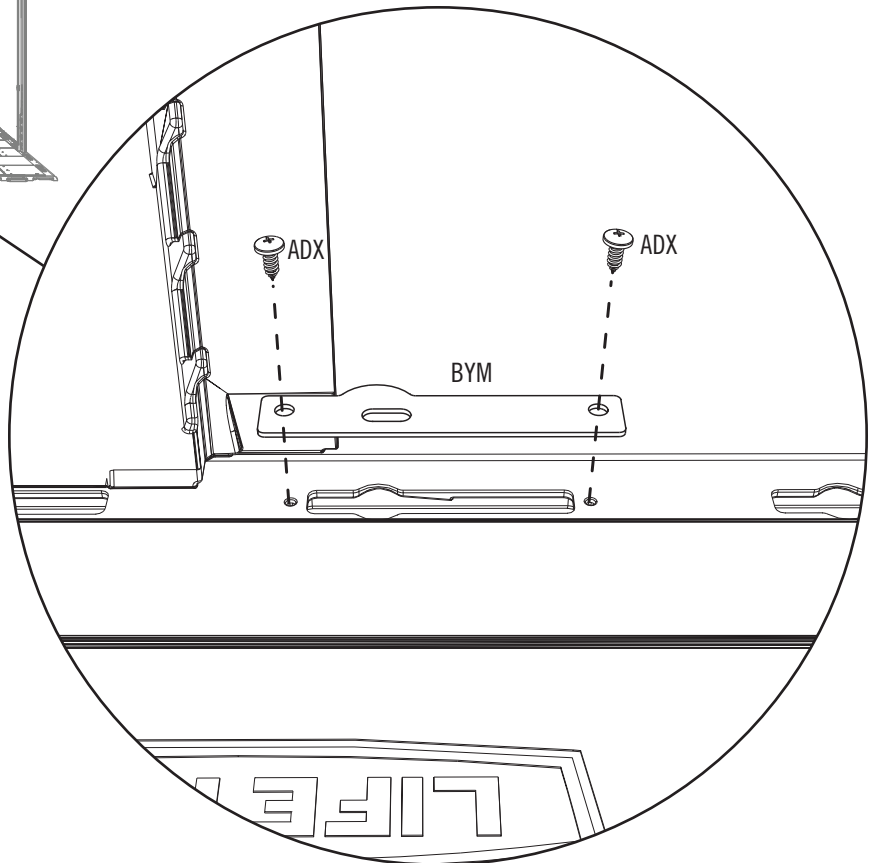
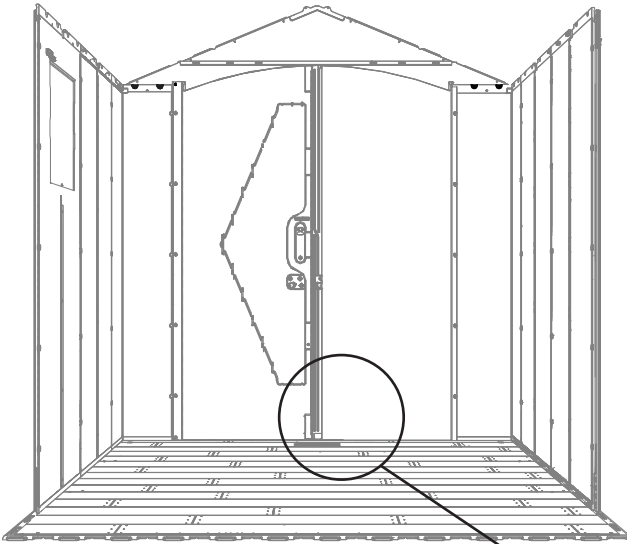



HARDWARE REQUIRED / QUINCAILLERIE REQUISE / HERRAJE REQUERIDO

Hardware Bag / Sac de quincaillerie / Bolsa de herraje

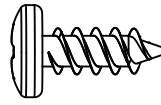

ADZ (x130)

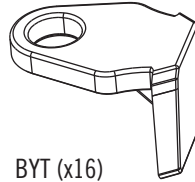

BYT (x16)

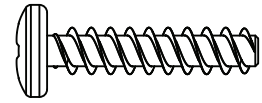

ADV (x40)



PARTS REQUIRED / PIÈCES REQUISES / PIEZAS REQUERIDAS

Metal Parts / Pièces en métal / Piezas de metal

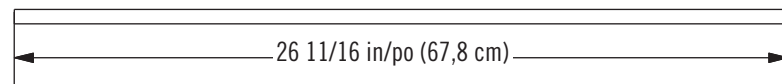

BYY (x10)

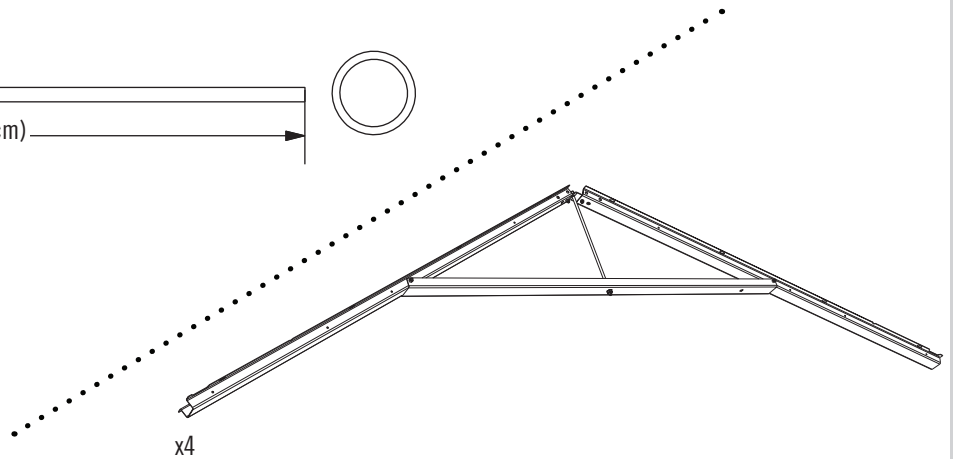

Plastic Parts / Pièces en plastique / Piezas de plástico

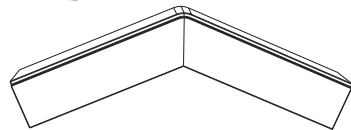

BYW (x2)

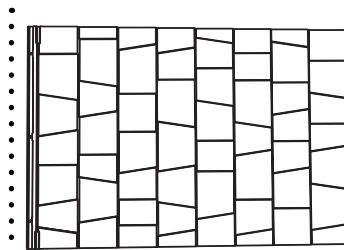

AGQ (x10)

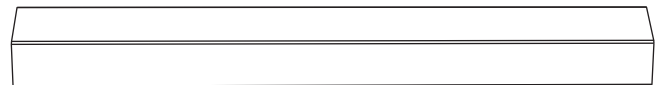

BYV (x1)

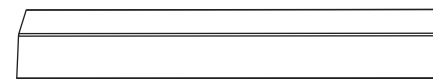

FYV (x1)

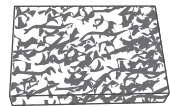

BYX (x4)

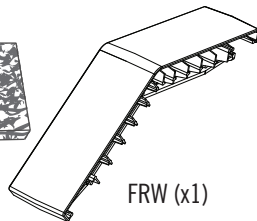

FRW (x1)

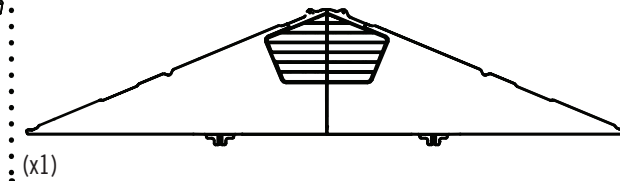

(x1)



TOOLS REQUIRED / OUTILS REQUIS / INSTRUMENTAL REQUERIDO



► SECTION 10 (CONTINUED) / SECTION 10 (SUITE) / SECCIÓN 10 (CONTINUACIÓN)

TOOLS AND HARDWARE REQUIRED / OUTILS ET QUINCAILLERIE REQUIS / INSTRUMENTAL Y HERRAJE REQUERIDOS



10.1

- Insert a **Support Tube (BYY)** into the notches of a **Roof Support Panel (AGQ)**. Repeat this step for all Roof Panels.
- Insérer un **tube de support (BYY)** dans les encoches du **panneau de toit (AGQ)**. Répéter cette étape pour tous les panneaux de toit.
- Insertar un **tubo de soporte (BYY)** en la muescas del **panel de tejado (AGQ)**. Repetir este paso para todos los paneles de tejado.

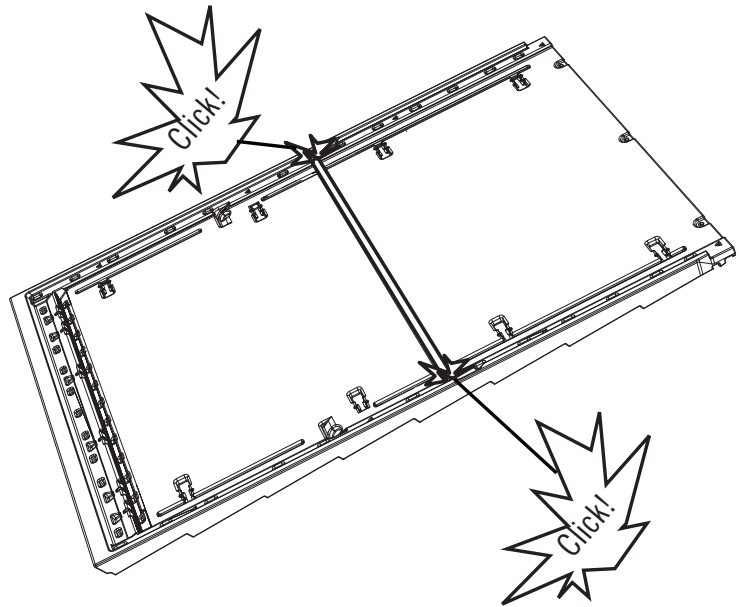
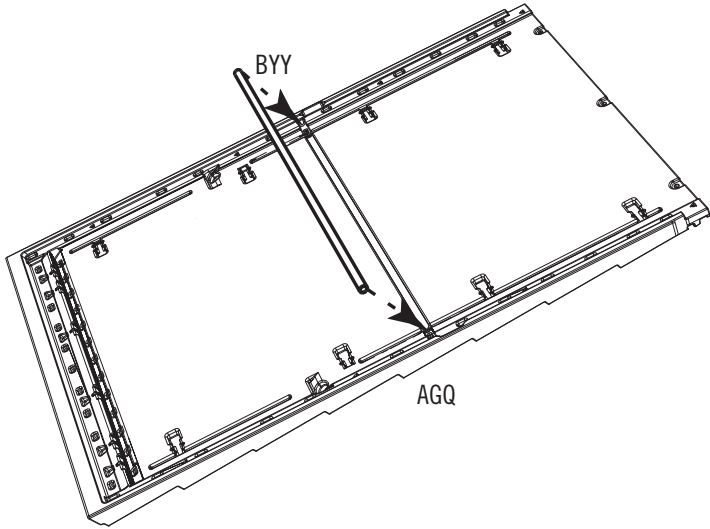

► SECTION 10 (CONTINUED) / SECTION 10 (SUITE) / SECCIÓN 10 (CONTINUACIÓN)

TOOLS AND HARDWARE REQUIRED / OUTILS ET QUINCAILLERIE REQUIS / INSTRUMENTAL Y HERRAJE REQUERIDOS

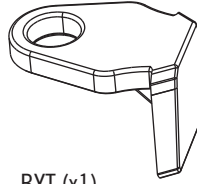

BYT (x1)

10.2

- Lay a Roof Panel upside down as shown. Orient a **Gable Clip (BYT)** as shown, and insert it at an angle into the bottom-most clip slot. Use a screwdriver to press down firmly to snap the Clip into place.
- Mettre un panneau de toit comme illustré. Orienter un **clip de pignon (BYT)** comme illustré, et insérer-le à un angle dans la fente la plus inférieure. Employer un tournevis pour presser bien le clip en place.
- Colocar un panel de techo como se muestra. Orientar un **clip de fachada (BYT)** como se muestra, e insertarlo a un ángulo en la ranura la más inferior. Usar un destornillador para presionar bien el clip en su lugar.

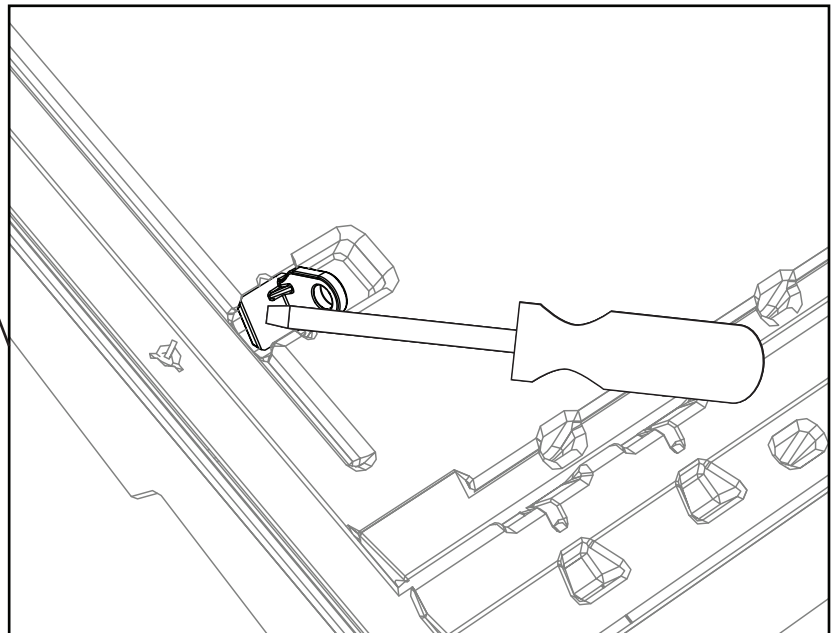
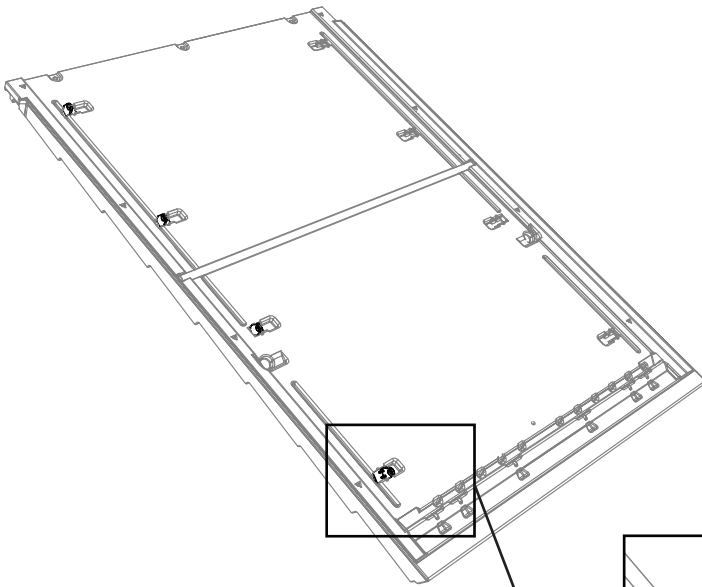

► SECTION 10 (CONTINUED) / SECTION 10 (SUITE) / SECCIÓN 10 (CONTINUACIÓN)

TOOLS AND HARDWARE REQUIRED / OUTILS ET QUINCAILLERIE REQUIS / INSTRUMENTAL Y HERRAJE REQUERIDOS

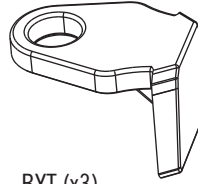

BYT (x3)

10.3

- Orient the next three **Gable Clips (BYT)** as shown, and insert them at an angle into the three top-most clip slots. Use a screwdriver to press down firmly to snap the Clips into place.
- Orienter les trois prochains **clips de pignon (BYT)** comme illustré, et insérer-les à un angle dans les trois fentes les plus supérieures. Employer un tournevis pour presser bien les clips en place.
- Orientar los tres próximos **clips de fachada (BYT)** como se muestra, e insertarlos a un ángulo en las tres ranuras las más superiores. Usar un destornillador para presionar bien los clips en su lugar.

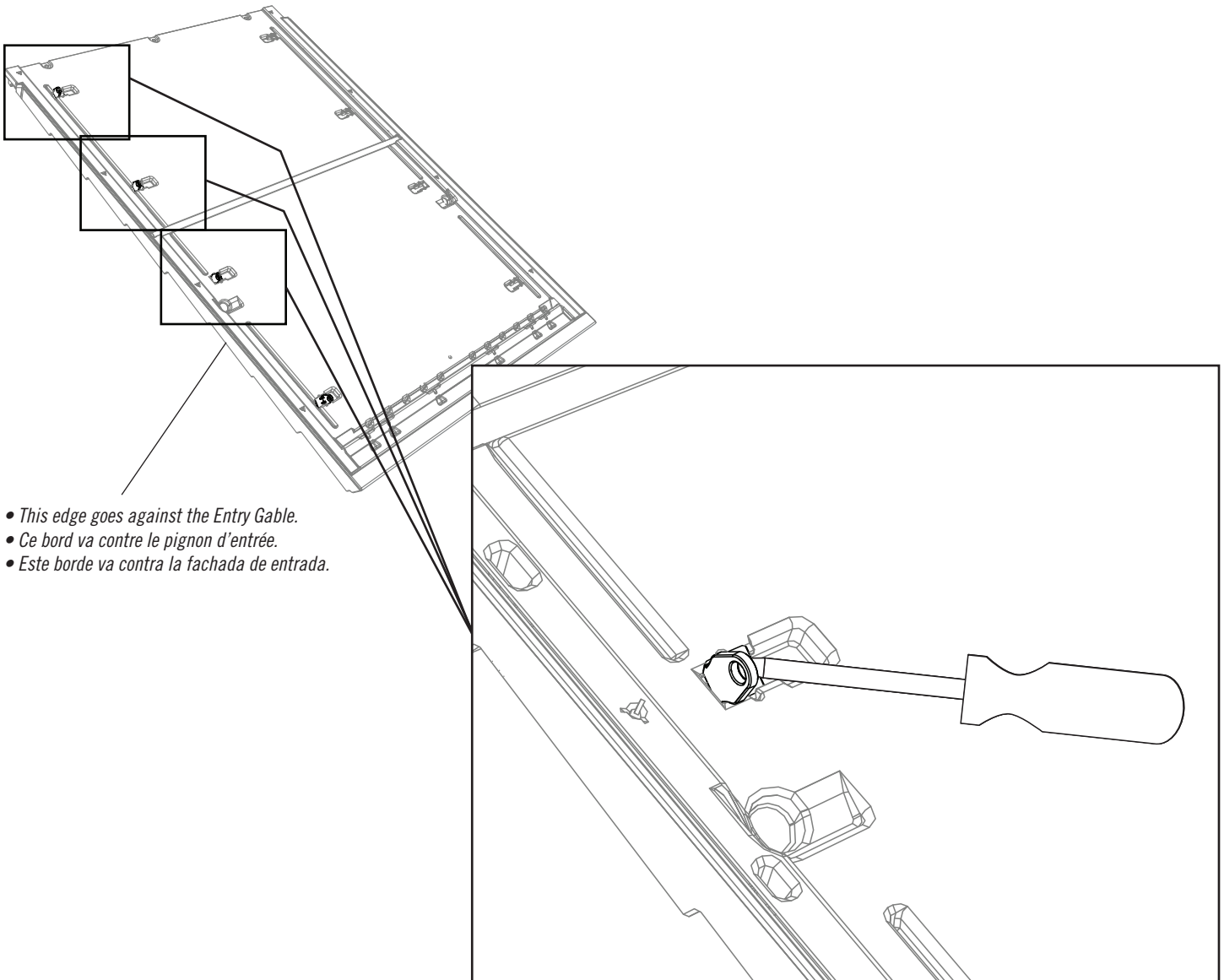

► SECTION 10 (CONTINUED) / SECTION 10 (SUITE) / SECCIÓN 10 (CONTINUACIÓN)

TOOLS AND HARDWARE REQUIRED / OUTILS ET QUINCAILLERIE REQUIS / INSTRUMENTAL Y HERRAJE REQUERIDOS



10.2

- Set a Truss Assembly into the notches on the first two opposite Wall Panels. Set a Roof Panel onto the Gable, Wall Panel, and Truss Assembly.
- Mettre une ferme dans les encoches des premiers deux panneaux muraux opposés. Mettre un panneaux de toit sur le toit à pignon, panneau mural, et la ferme.
- Colocar una cercha dentro de las muescas de los primeros dos paneles murales opuestos. Colocar un panel de tejado sobre la fachada de entrada, panel mural, y la cercha.

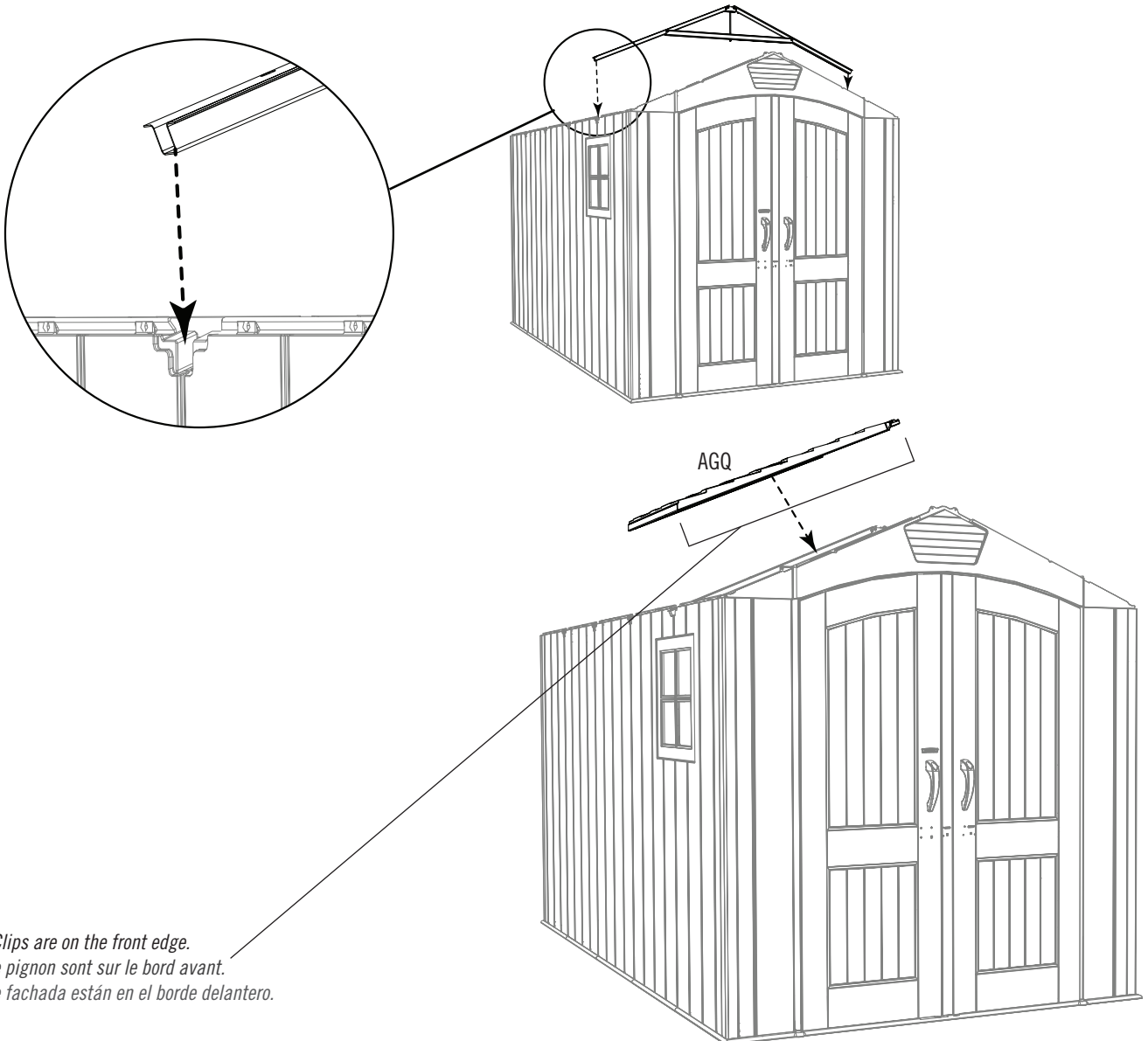

- The Gable Clips are on the front edge.
- Les clips de pignon sont sur le bord avant.
- Los clips de fachada están en el borde delantero.

► SECTION 10 (CONTINUED) / SECTION 10 (SUITE) / SECCIÓN 10 (CONTINUACIÓN)

TOOLS AND HARDWARE REQUIRED / OUTILS ET QUINCAILLERIE REQUIS / INSTRUMENTAL Y HERRAJE REQUERIDOS

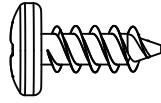

ADZ (x4)

10.5

- The groove along the bottom of the Roof Panel goes over the top of the Wall Panel.
- La rainure le long du bord inférieur du panneau de toit va sur le bord supérieur du panneau mural.
- La ranura a lo largo del borde inferior del panel de techo va encima del borde superior del panel mural.

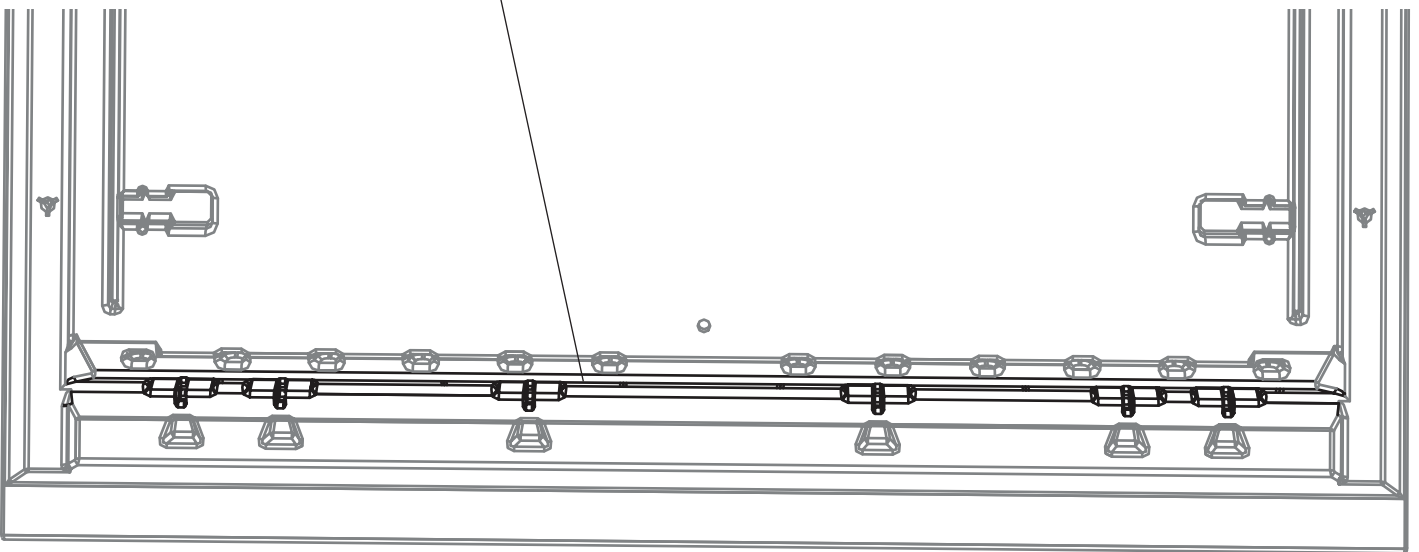

10.6

- Align the Clips with the holes on the inside of the Entry Gable, and insert four (4) **Screws (ADZ)** to secure the Gable to the Roof Panel.
- Aligner les clips de pignon avec les trous dans l'intérieur du pignon d'entrée, et insérer quatre (4) **vis (ADZ)** pour fixer le pignon au panneau de toit.
- Alinear los clips de fachada con los agujeros en el interior de la fachada de entrada, e insertar cuatro (4) **tornillos (ADZ)** para fijar la fachada al panel de techo.

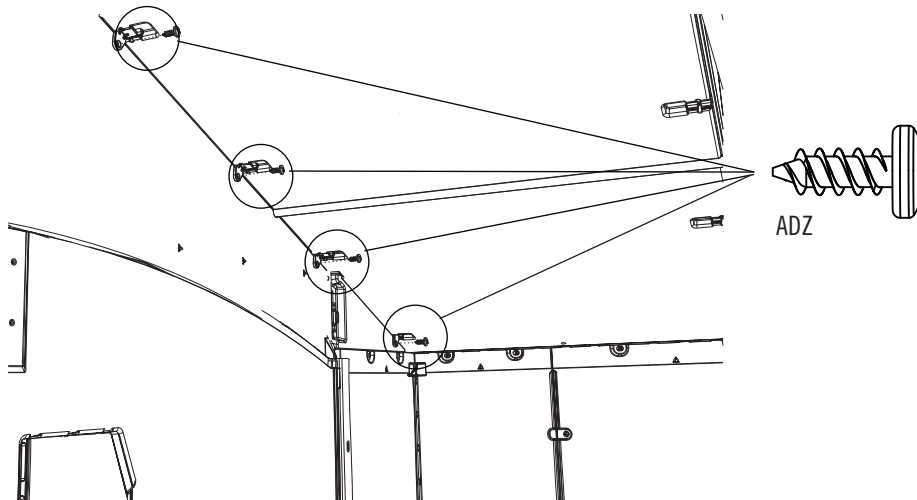

► SECTION 10 (CONTINUED) / SECTION 10 (SUITE) / SECCIÓN 10 (CONTINUACIÓN)

TOOLS AND HARDWARE REQUIRED / OUTILS ET QUINCAILLERIE REQUIS / INSTRUMENTAL Y HERRAJE REQUERIDOS

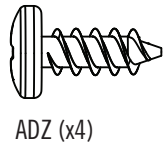
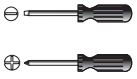

ADZ (x4)

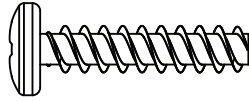

ADV (x4)

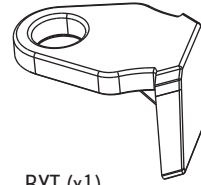

BYT (x1)

10.7

- Insert four (4) long **Screws (ADV)** along the top edge of the Wall Panel and four (4) short **Screws (ADZ)** along the Truss as shown.
- Insérer quatre (4) **vis (ADV)** le long du bord supérieur du panneau mural et quatre (4) **vis (ADZ)** courtes à travers la ferme comme illustré.
- Insertar cuatro (4) **tornillos (ADV)** largos a lo largo del borde superior del panel mural y cuatro (4) **tornillos (ADZ)** cortos a través de la cercha como se muestra.

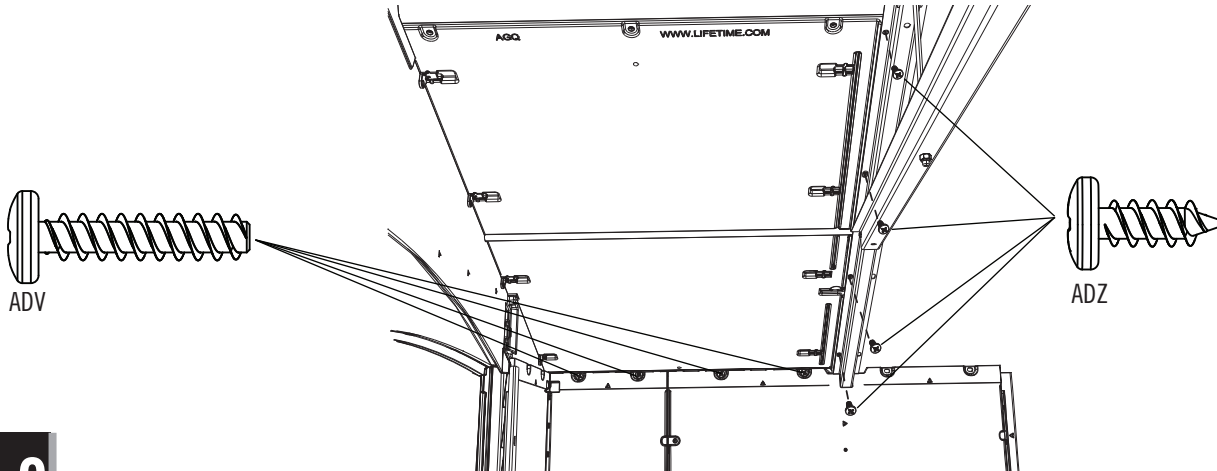

10.8

- Lay the next Roof Panel upside down as shown. Orient a **Gable Clip (BYT)** as shown, and insert it at an angle into the bottom-most clip slot. Use a screwdriver to press down firmly to snap the Clip into place.
- Mettre un panneau de toit comme illustré. Orienter un **clip de pignon (BYT)** comme illustré, et insérer-le à un angle dans la fente la plus inférieure. Employer un tournevis pour presser bien le clip en place.
- Colocar un panel de techo como se muestra. Orientar un **clip de fachada (BYT)** como se muestra, e insertarlo a un ángulo en la ranura la más inferior. Usar un destornillador para presionar bien el clip en su lugar.

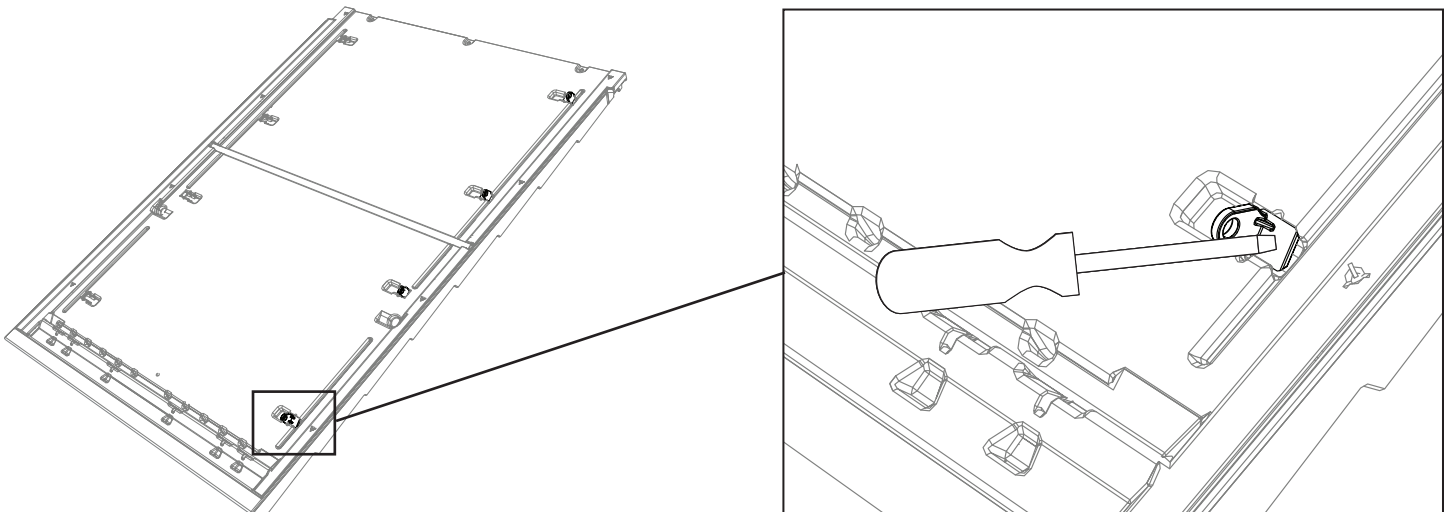

► SECTION 10 (CONTINUED) / SECTION 10 (SUITE) / SECCIÓN 10 (CONTINUACIÓN)

TOOLS AND HARDWARE REQUIRED / OUTILS ET QUINCAILLERIE REQUIS / INSTRUMENTAL Y HERRAJE REQUERIDOS

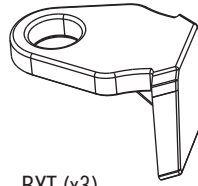

BYT (x3)

10.9

- Orient the next three **Gable Clips (BYT)** as shown, and insert them at an angle into the three top-most clip slots. Use a screwdriver to press down firmly to snap the Clips into place.
- Orienter les trois prochains **clips de pignon (BYT)** comme illustré, et insérer-les à un angle dans les trois fentes les plus supérieures. Employer un tournevis pour presser bien les clips en place.
- Orientar los tres próximos **clips de fachada (BYT)** como se muestra, e insertarlos a un ángulo en las tres ranuras las más superiores. Usar un destornillador para presionar bien los clips en su lugar.

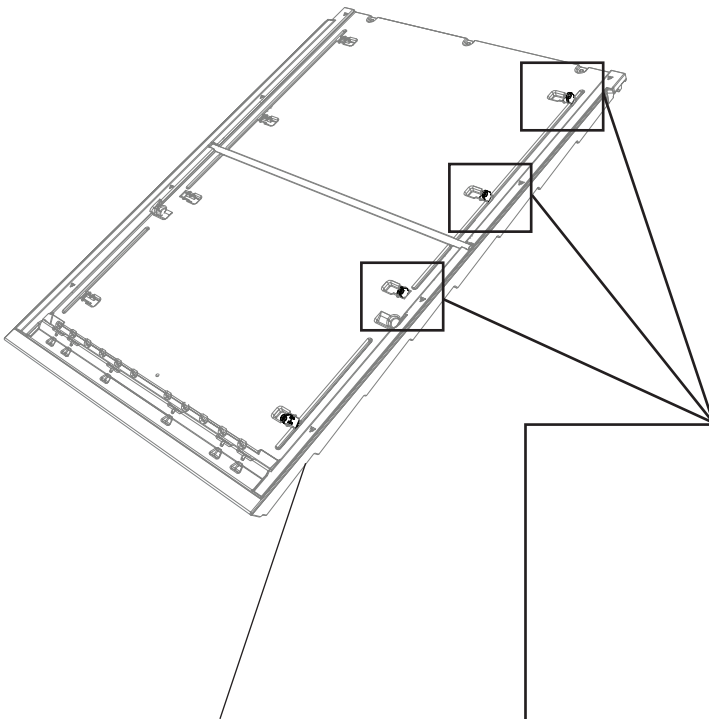

- *This edge goes against the Entry Gable.*
- *Ce bord va contre le pignon d'entrée.*
- *Este borde va contra la fachada de entrada.*

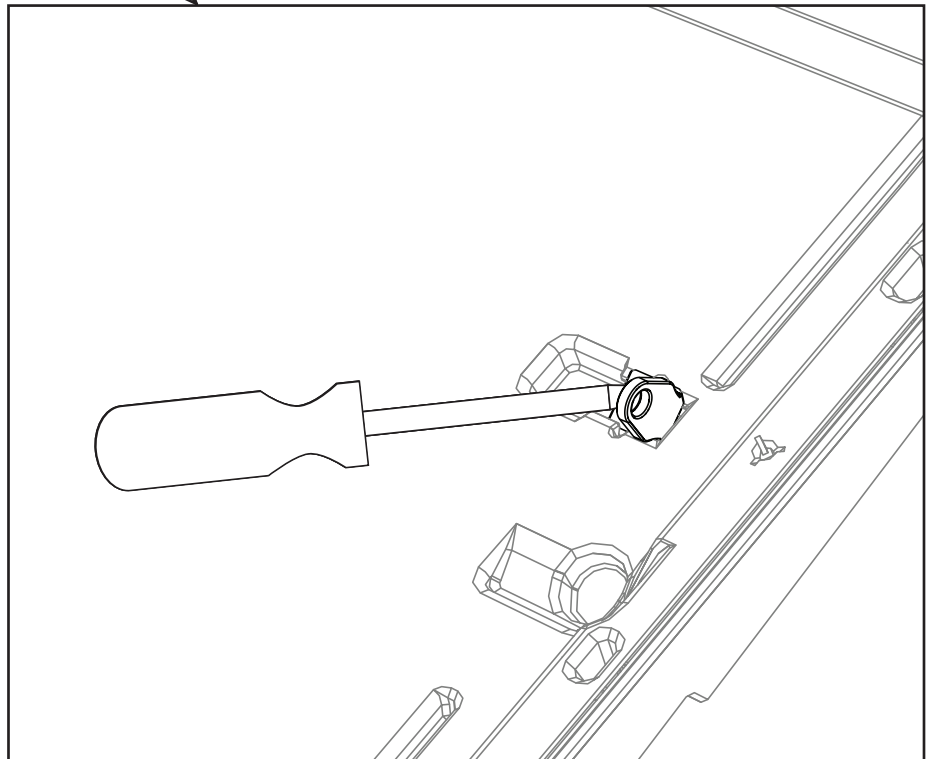

► SECTION 10 (CONTINUED) / SECTION 10 (SUITE) / SECCIÓN 10 (CONTINUACIÓN)

TOOLS AND HARDWARE REQUIRED / OUTILS ET QUINCAILLERIE REQUIS / INSTRUMENTAL Y HERRAJE REQUERIDOS

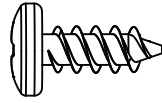

ADZ (x4)

10.10

• Set the Roof Panel from steps 10.8–10.9 onto the Entry Gable, Wall Panel, and Truss Assembly. **The Gable Clips should be against the Entry Gable.**

• Mettre le panneau de toit des étapes 10.8 – 10.9 sur le pignon d'entrée, panneau mural, et la ferme. **Les clips de pignon doivent être contre le pignon d'entrée.**

• Colocar el panel de techo de los pasos 10.8–10.9 sobre la fachada de entrada, panel mural, y la cercha. **Los clips de fachada deben estar contra la fachada de entrada.**

- *The Gable Clips are on this edge.*
- *Les clips de pignon sont sur ce bord.*
- *Los clips de fachada están en este borde.*

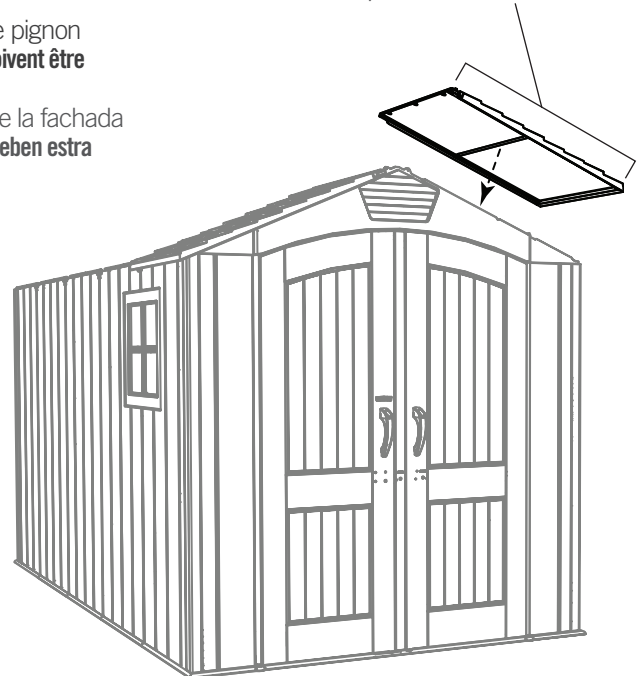

10.11

• Align the Clips with the holes in the Entry Gable, and insert four (4) **Screws (ADZ)** to secure the Gable to the Roof Panel.

• Aligner les clips de pignon avec les trous dans le pignon d'entrée, et insérer quatre (4) **vis (ADZ)** pour fixer le pignon au panneau de toit.

• Alinear los clips de fachada con los agujeros en la fachada de entrada, e insertar cuatro (4) **tornillos (ADZ)** para fijar la fachada al panel de techo.

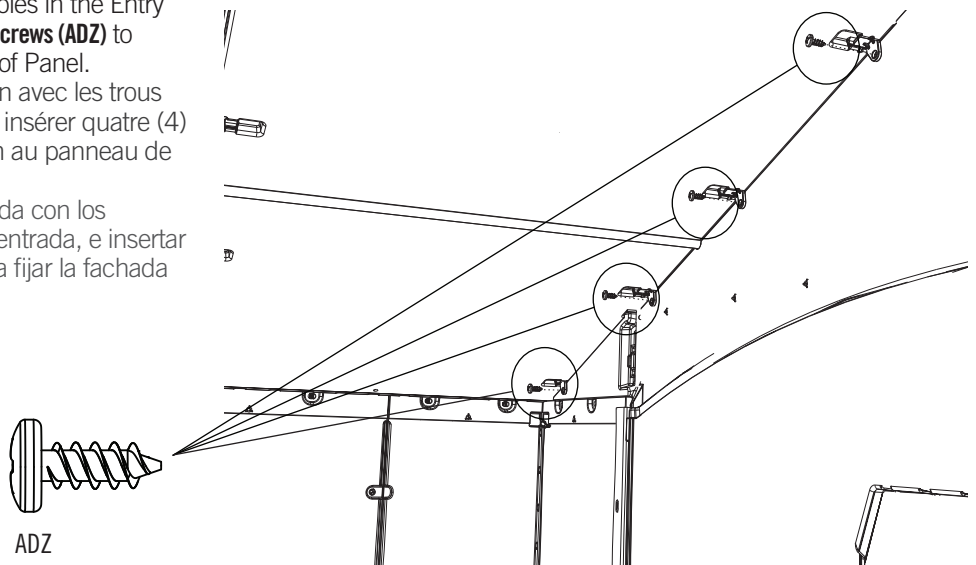

► SECTION 10 (CONTINUED) / SECTION 10 (SUITE) / SECCIÓN 10 (CONTINUACIÓN)

TOOLS AND HARDWARE REQUIRED / OUTILS ET QUINCAILLERIE REQUIS / INSTRUMENTAL Y HERRAJE REQUERIDOS

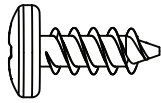

ADZ (x4)

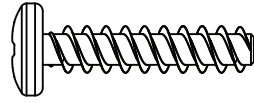

ADV (x4)

10.12

- Insert four (4) long **Screws (ADV)** along the top edge of the Wall Panel and four (4) short **Screws (ADZ)** along the Truss as shown.
- Insérer quatre (4) **vis (ADV)** le long du bord supérieur du panneau mural et quatre (4) **vis (ADZ)** courtes à travers la ferme comme illustré.
- Insertar cuatro (4) **tornillos (ADV)** largos a lo largo del borde superior del panel mural y cuatro (4) **tornillos (ADZ)** cortos a través de la cercha como se muestra.

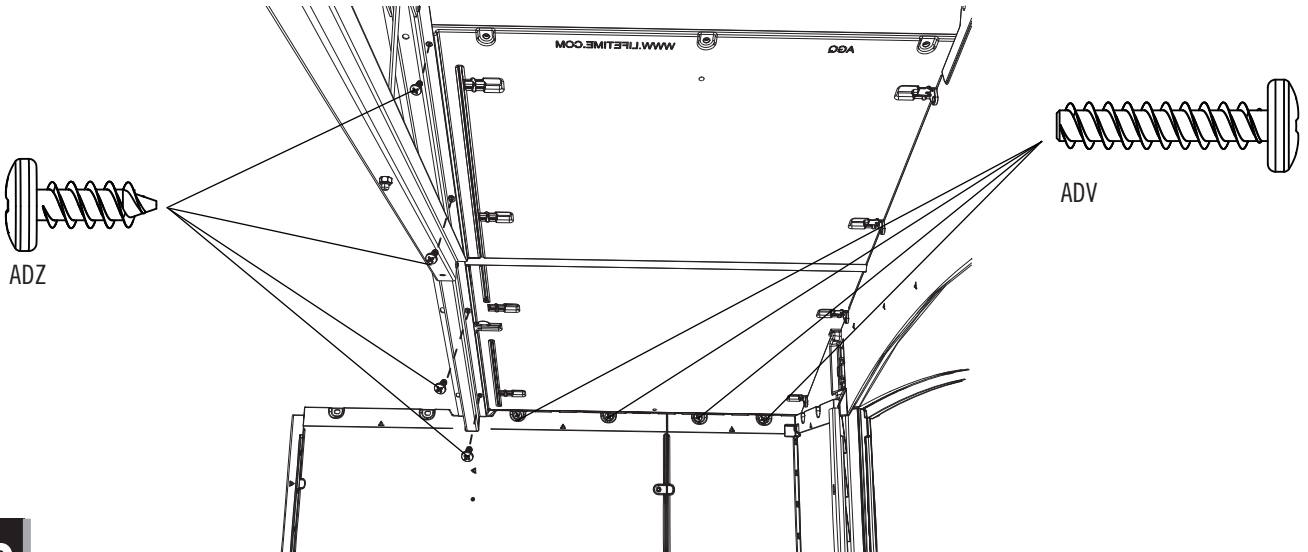

10.13

- Set a Truss Assembly into the notches on the second two opposite Wall Panels. Set a Roof Panel onto the Gable, Wall Panel, and Truss Assembly.
- Mettre une ferme dans les encoches des premiers deux panneaux muraux opposés. Mettre un panneau de toit sur le toit à pignon, panneau mural, et la ferme.
- Colocar una cercha dentro de las muescas de los primeros dos paneles murales opuestos. Colocar un panel de tejado sobre la fachada de entrada, panel mural, y la cercha.

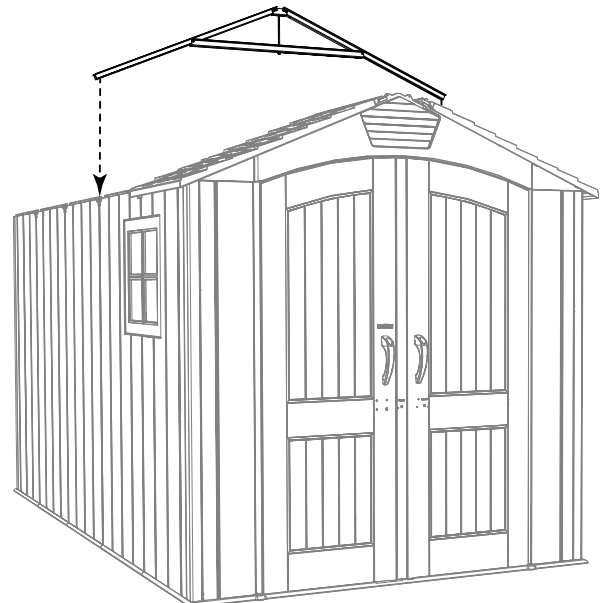

► SECTION 10 (CONTINUED) / SECTION 10 (SUITE) / SECCIÓN 10 (CONTINUACIÓN)

TOOLS AND HARDWARE REQUIRED / OUTILS ET QUINCAILLERIE REQUIS / INSTRUMENTAL Y HERRAJE REQUERIDOS

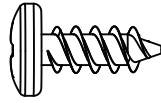

ADZ (x8)

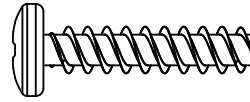

ADV (x4)

10.14

• Set a Roof Panel onto the Gable, Wall Panel, and Truss Assembly, and secure it with the hardware shown. **Only insert the long Screws (ADV) along the top edge of the Wall Panel.**

• Mettre un panneau de toit sur le toit à pignon, panneau mural, et la ferme, et attacher-le à l'aide des accessoires illustrés. **N'insérer les vis (ADV) courtes que le long du bord supérieur du panneau mural.**

• Colocar un panel de tejado sobre la fachada de entrada, panel mural, y la cercha, y sujetarlo usando el herraje indicado. **Insertar los tornillos (ADV) largos sólo a lo largo del borde superior del panel mural.**

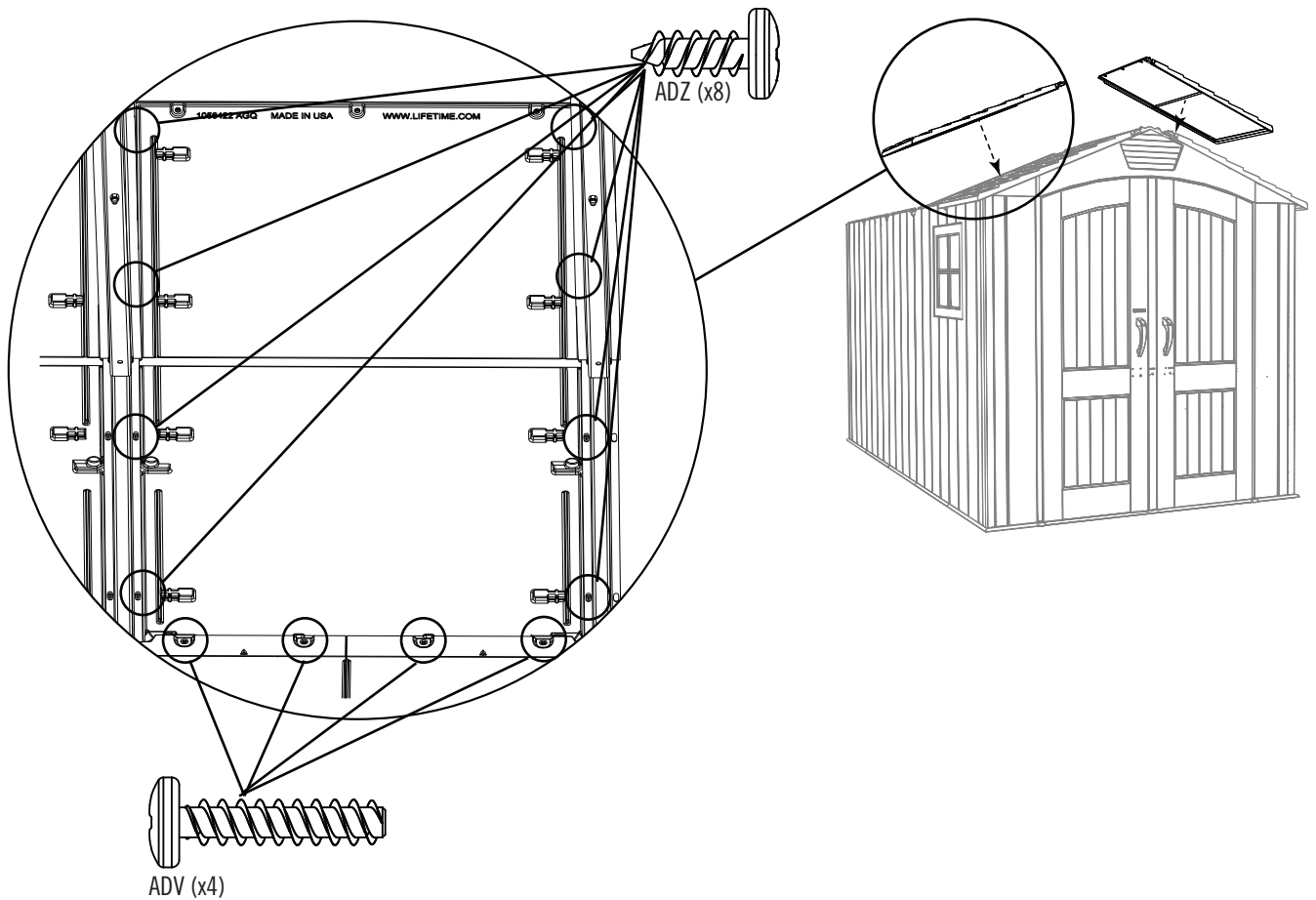

► SECTION 10 (CONTINUED) / SECTION 10 (SUITE) / SECCIÓN 10 (CONTINUACIÓN)

TOOLS AND HARDWARE REQUIRED / OUTILS ET QUINCAILLERIE REQUIS / INSTRUMENTAL Y HERRAJE REQUERIDOS

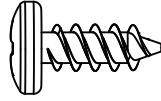

ADZ (x8)

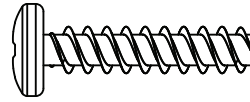

ADV (x4)

10.15

- Repeat the last step for the opposite Roof Panel. Only insert the long **Screws (ADV)** along the top edge of the Wall Panel.
- Répéter l'étape précédente pour le panneau de toit opposé. N'insérer les **vis (ADV)** courtes que le long du bord supérieur du panneau mural.
- Repetir el paso anterior para el panel de tejado opuesto. Insertar los **tornillos (ADV)** largos sólo a lo largo del borde superior del panel mural.

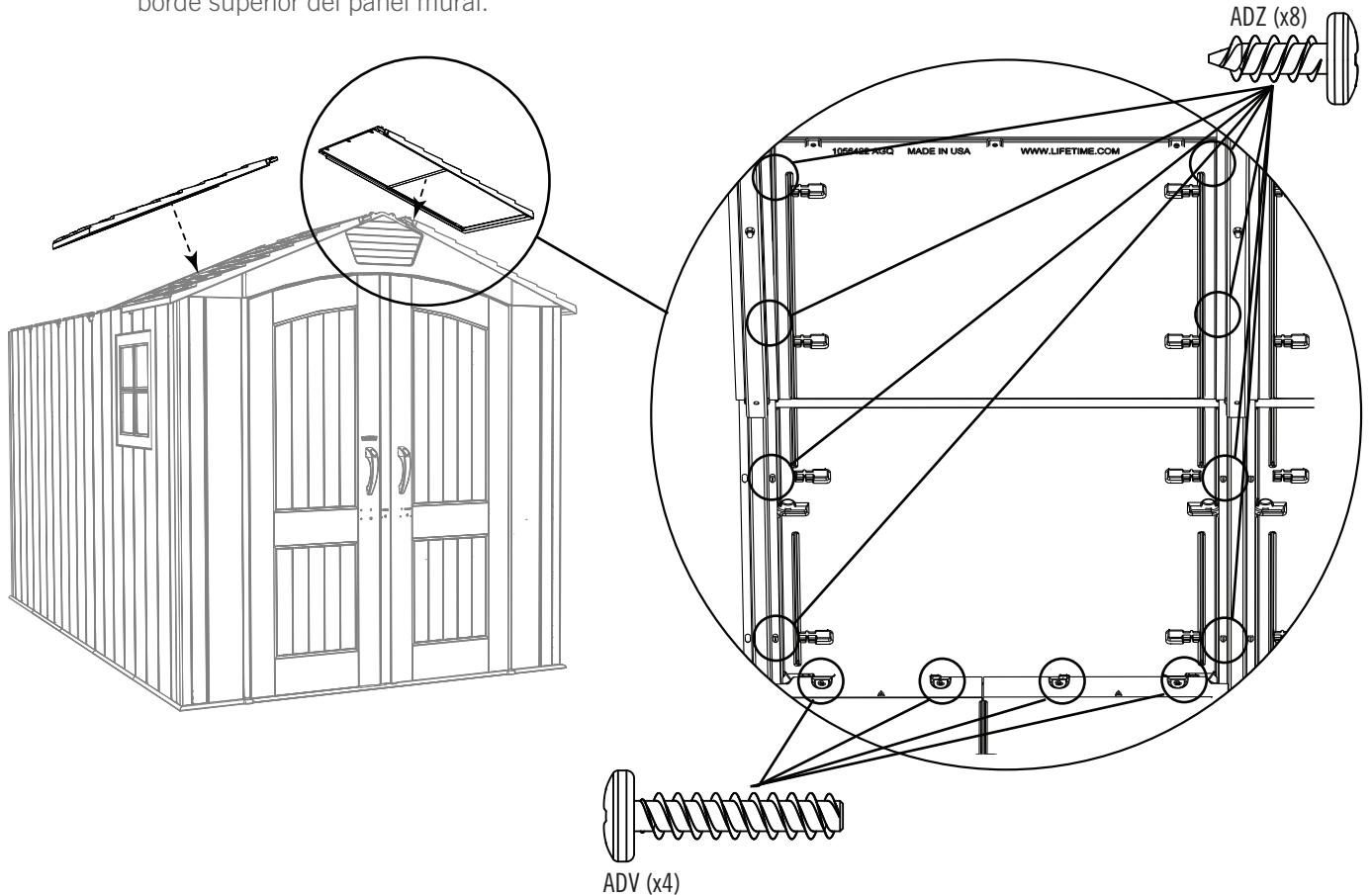

► SECTION 10 (CONTINUED) / SECTION 10 (SUITE) / SECCIÓN 10 (CONTINUACIÓN)

TOOLS AND HARDWARE REQUIRED / OUTILS ET QUINCAILLERIE REQUIS / INSTRUMENTAL Y HERRAJE REQUERIDOS

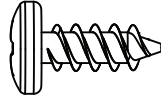

ADZ (x32)

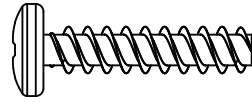

ADV (x16)

10.16

- Repeat steps 10.13–10.15 for the next two Trusses and the next four Roof Panels.
- Répéter les étapes 10.13 – 10.15 pour les deux fermes suivantes et les quatre panneaux de toit suivants.
- Repetir los pasos 10.13–10.15 para las próximas dos cerchas y los próximos dos paneles de tejado.

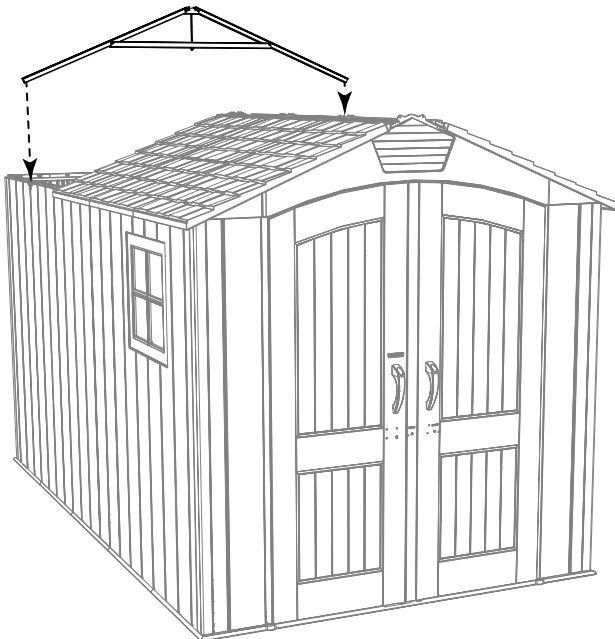
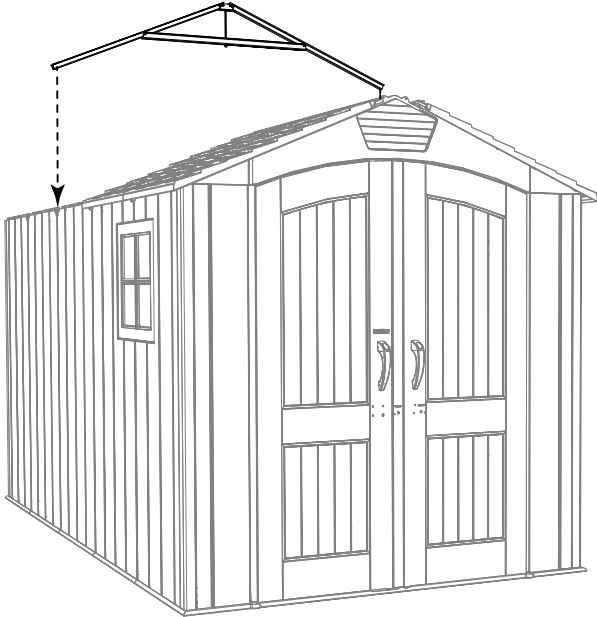

► SECTION 10 (CONTINUED) / SECTION 10 (SUITE) / SECCIÓN 10 (CONTINUACIÓN)

TOOLS AND HARDWARE REQUIRED / OUTILS ET QUINCAILLERIE REQUIS / INSTRUMENTAL Y HERRAJE REQUERIDOS

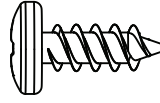

ADZ (x12)

10.17

- Set the Rear Gable onto the back Wall Panels, and secure with twelve (12) **Screws (ADZ)**.
- Mettre le pignon arrière aux panneaux muraux arrière, et attacher-le à l'aide de douze (12) **vis (ADZ)**.
- Colocar la fachada trasera en los paneles murales traseros, y sujetarla usando doce (12) **tornillos (ADZ)**.

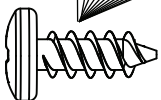
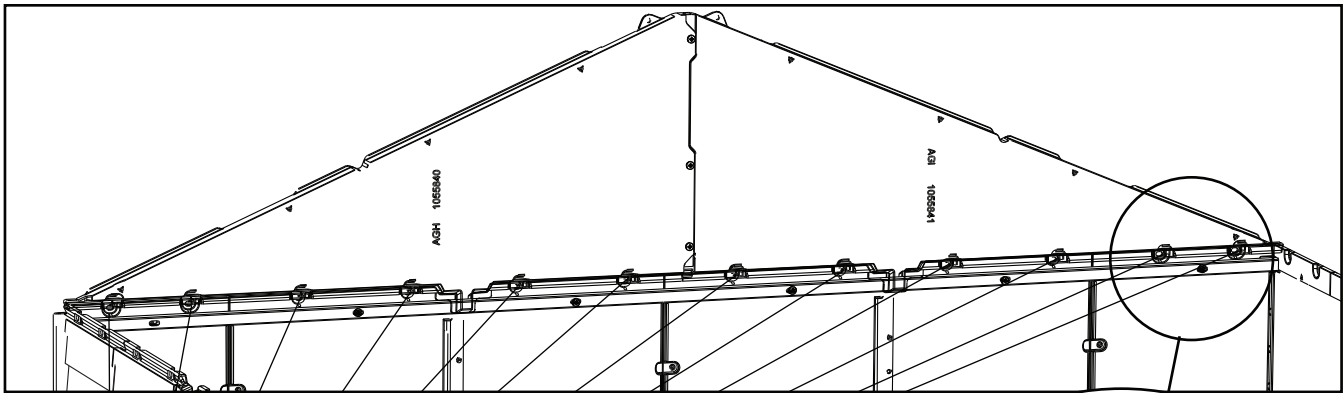
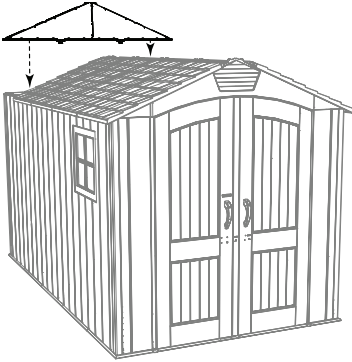

ADZ

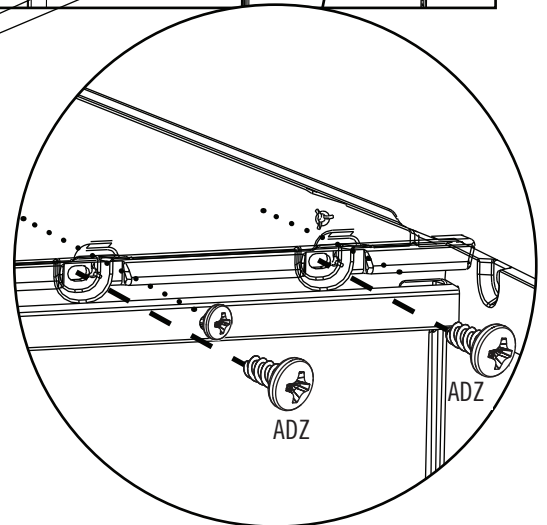

► SECTION 10 (CONTINUED) / SECTION 10 (SUITE) / SECCIÓN 10 (CONTINUACIÓN)

TOOLS AND HARDWARE REQUIRED / OUTILS ET QUINCAILLERIE REQUIS / INSTRUMENTAL Y HERRAJE REQUERIDOS

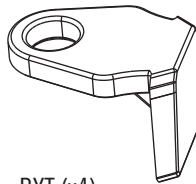

BYT (x4)

10.18

- Lay a Roof Panel upside down as shown. Orient four (4) **Gable Clips (BYT)** as shown, and insert them at an angle into the four slots along the edge of the Roof Panel. **Orient all four Clips face the same way.** Press down with a screwdriver to snap the Clips into place.
- Mettre un panneau de toit comme illustré. Orienter quatre (4) **clips de pignon (BYT)** comme illustré, et insérer-les à un angle dans les fentes le long du bord du panneau de toit. **Orienter tous les quatre clips vont dans la même direction.** Employer un tournevis pour presser bien les clip en place.
- Colocar un panel de techo como se muestra. Orienter cuatro (4) **clips de fachada (BYT)** como se muestra, e insertarlos a un ángulo en las ranuras a lo largo del panel de techo. **Orienter todos los cuatro clips en la misma dirección.** Usar un destornillador para presionar bien los clips en sus lugares.

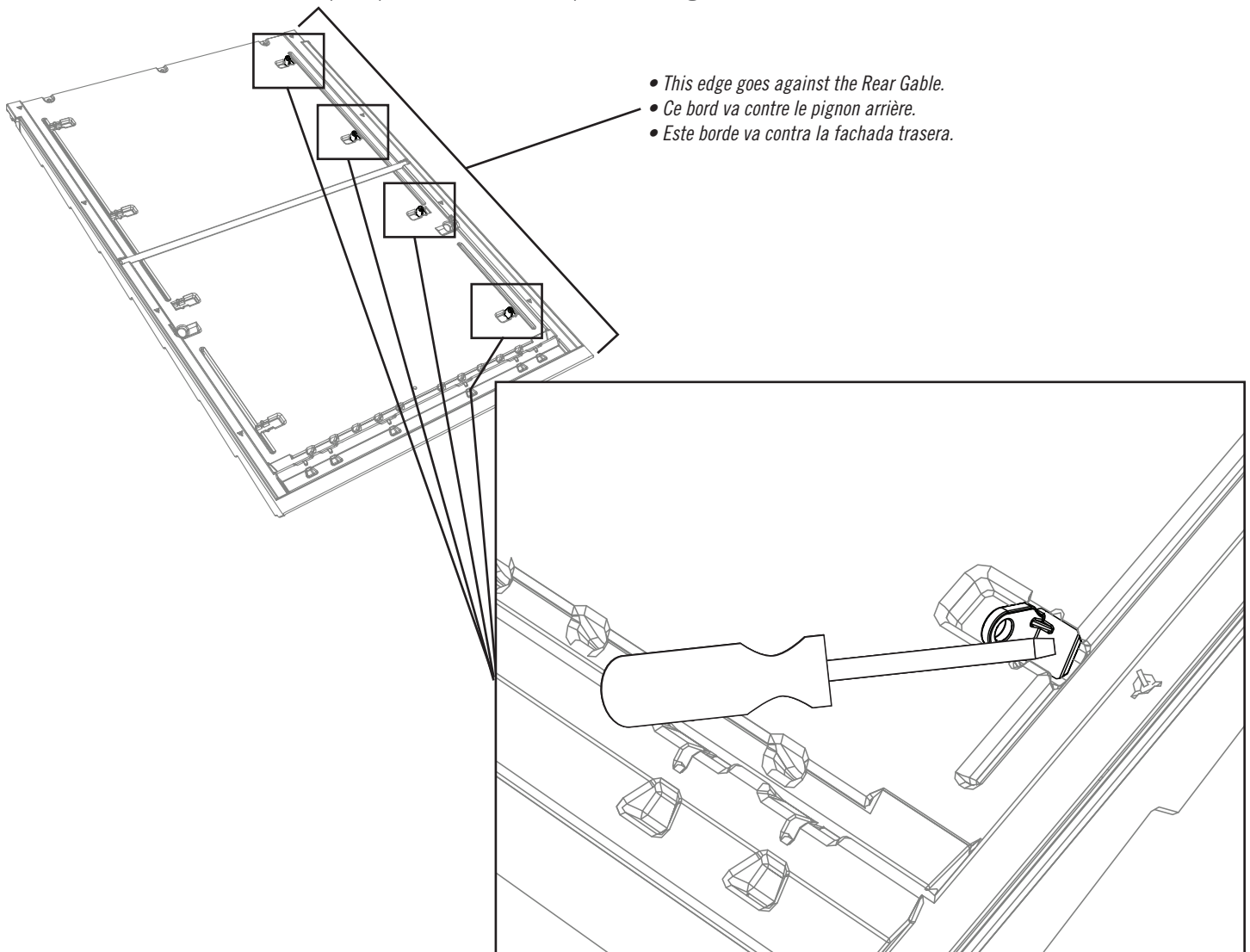

► SECTION 10 (CONTINUED) / SECTION 10 (SUITE) / SECCIÓN 10 (CONTINUACIÓN)

TOOLS AND HARDWARE REQUIRED / OUTILS ET QUINCAILLERIE REQUIS / INSTRUMENTAL Y HERRAJE REQUERIDOS

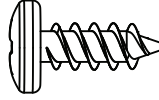

ADZ (x4)

10.19

- Set the Roof Panel from step 10.18 onto the Gable, Wall Panel, and Truss Assembly. Secure to the Gable with four (4) **Screws (ADZ)**. **The Clips go against the Gable.**
- Mettre le panneau de toit de l'étape 10.18 sur le pignon, panneau mural, et la ferme. Fixer-le au pignon avec quatre (4) **vis (ADZ)**. **Les clips vont contre le pignon.**
- Colocar el panel de tejado del paso 10.18 sobre la fachada de entrada, panel mural, y la cercha. Fijarlo a la fachada con cuatro (4) **tornillos (ADZ)**. **Los clips van contra la fachada.**

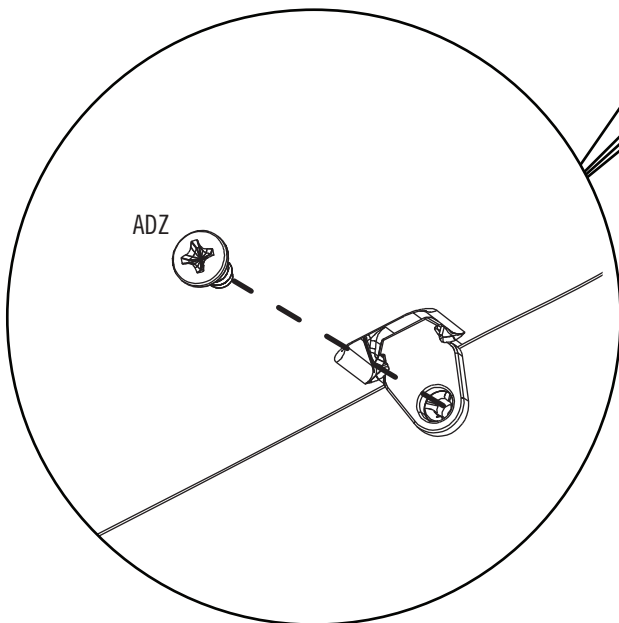
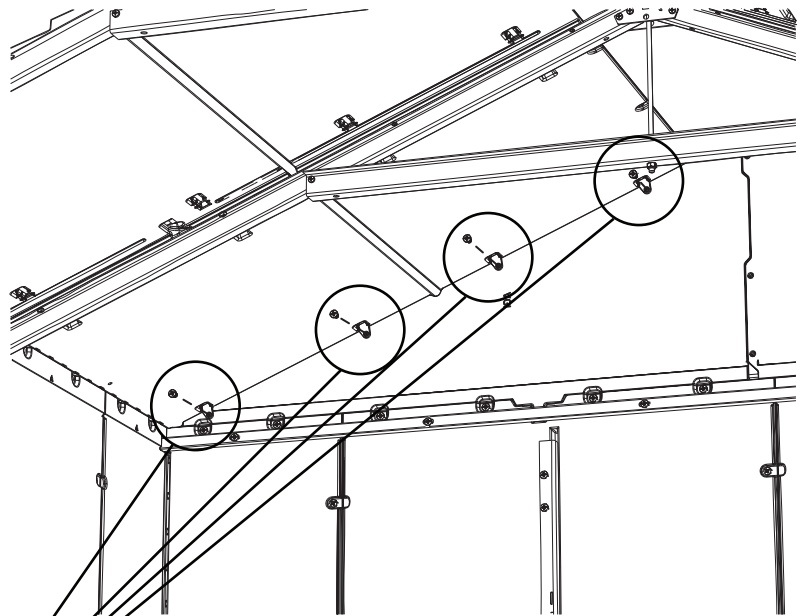
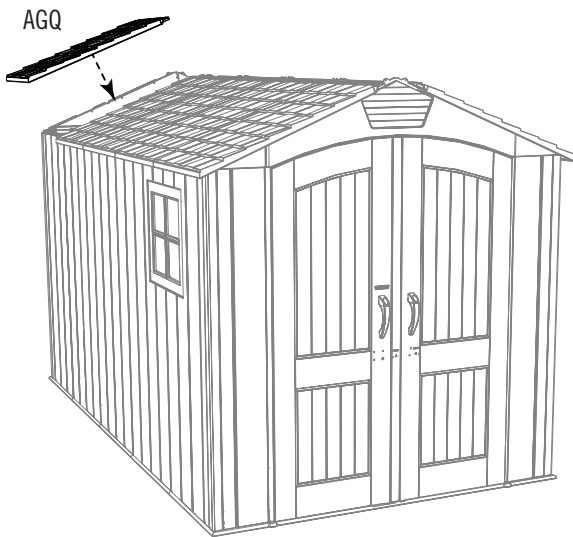

► SECTION 10 (CONTINUED) / SECTION 10 (SUITE) / SECCIÓN 10 (CONTINUACIÓN)

TOOLS AND HARDWARE REQUIRED / OUTILS ET QUINCAILLERIE REQUIS / INSTRUMENTAL Y HERRAJE REQUERIDOS

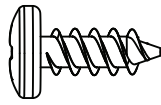

ADZ (x4)

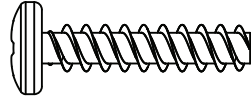

ADV (x4)

10.20

- Insert four (4) long **Screws (ADV)** along the top edge of the Wall Panel and four (4) short **Screws (ADZ)** along the Truss as shown. **Only insert the long Screws (ADV) along the top edge of the Wall Panel.**
- Insérer quatre (4) **vis (ADV)** le long du bord supérieur du panneau mural et quatre (4) **Vis (ADZ)** courtes à travers la ferme comme illustré. **N'insérer les vis (ADV) courtes que le long du bord supérieur du panneau mural.**
- Insertar cuatro (4) **tornillos (ADV)** largos a lo largo del borde superior del panel mural y cuatro (4) **tornillos (ADZ)** cortos a través de la cercha como se muestra. **Insertar los tornillos (ADV) largos sólo a lo largo del borde superior del panel mural.**

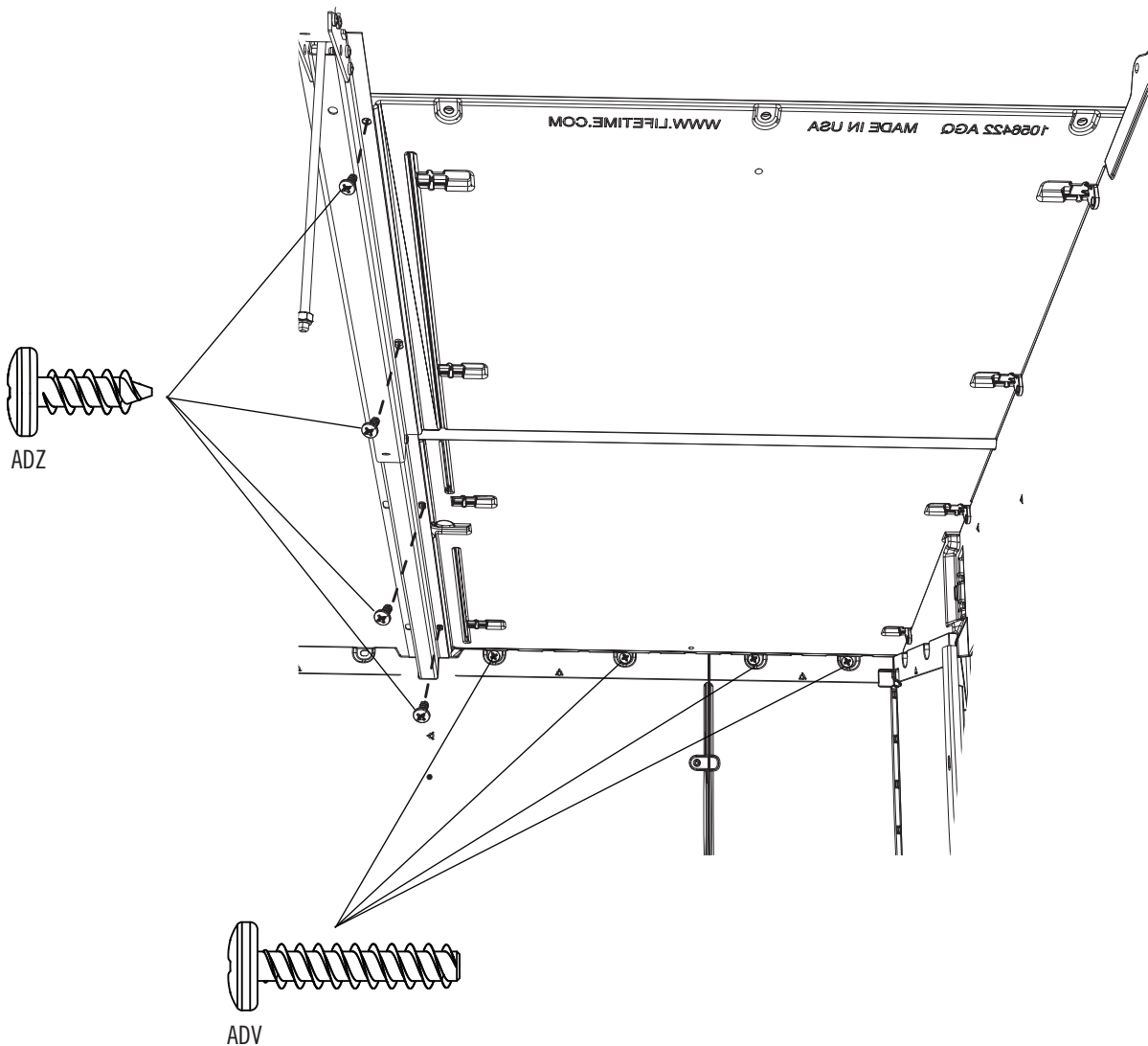

► SECTION 10 (CONTINUED) / SECTION 10 (SUITE) / SECCIÓN 10 (CONTINUACIÓN)

TOOLS AND HARDWARE REQUIRED / OUTILS ET QUINCAILLERIE REQUIS / INSTRUMENTAL Y HERRAJE REQUERIDOS

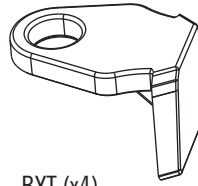

BYT (x4)

10.21

- Lay a Roof Panel upside down as shown. Orient four (4) **Gable Clips (BYT)** as shown, and insert them at an angle into the four slots along the edge of the Roof Panel. **Orient all four Clips face the same way.** Press down with a screwdriver to snap the Clips into place.
- Mettre un panneau de toit comme illustré. Orienter quatre (4) **clips de pignon (BYT)** comme illustré, et insérer-les à un angle dans les fentes le long du bord du panneau de toit. **Orienter tous les quatre clips vont dans la même direction.** Employer un tournevis pour presser bien les clip en place.
- Colocar un panel de techo como se muestra. Orienter cuatro (4) **clips de fachada (BYT)** como se muestra, e insertarlos a un ángulo en las ranuras a lo largo del panel de techo. **Orienter todos los cuatro clips en la misma dirección.** Usar un destornillador para presionar bien los clips en sus lugares.

- *This edge goes against the Rear Gable.*
- *Ce bord va contre le pignon arrière.*
- *Este borde va contra la fachada trasera.*

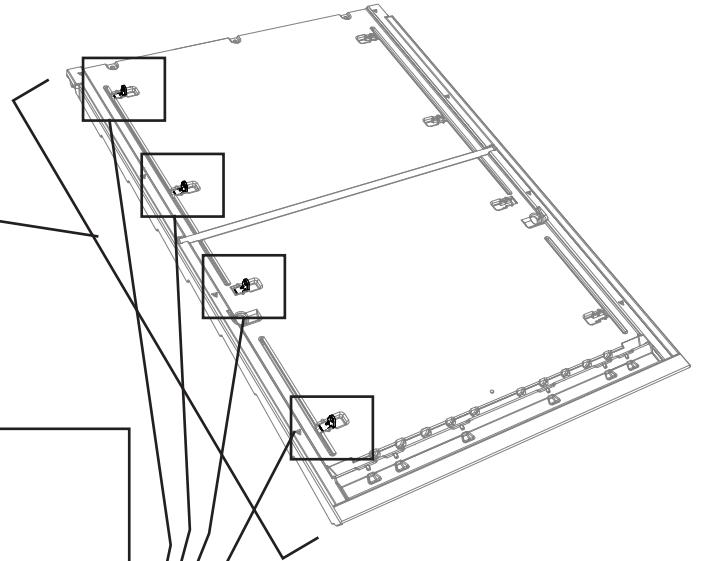
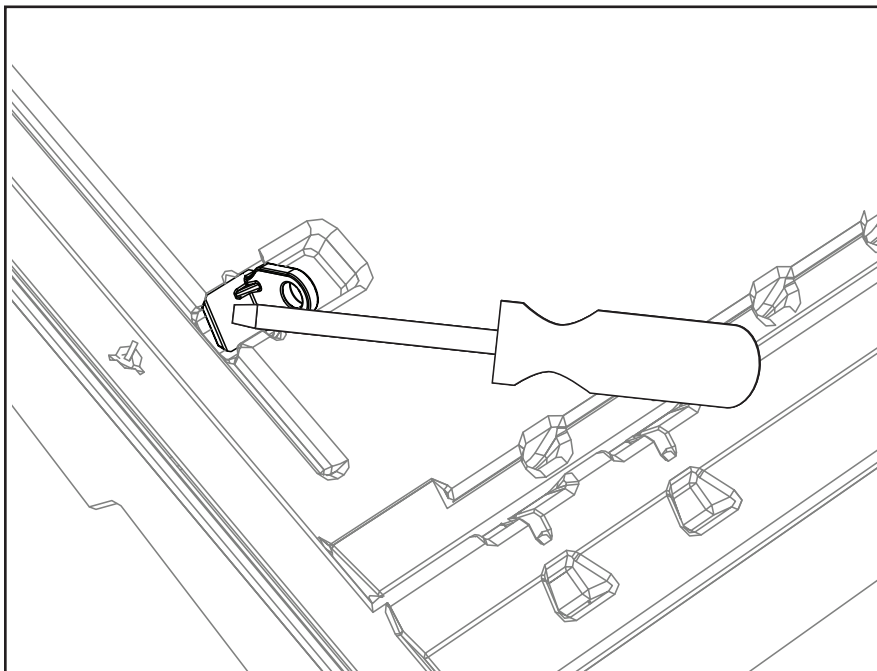

► SECTION 10 (CONTINUED) / SECTION 10 (SUITE) / SECCIÓN 10 (CONTINUACIÓN)

TOOLS AND HARDWARE REQUIRED / OUTILS ET QUINCAILLERIE REQUIS / INSTRUMENTAL Y HERRAJE REQUERIDOS

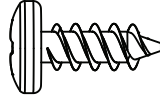

ADZ (x4)

10.22

- Set the Roof Panel onto the Gable, Wall Panel, and Truss Assembly. Orient the **Clips (BYT)** as shown in this image, and insert them in the locations indicated.
- Mettre le panneau de toit sur le pignon, panneau mural, et la ferme. Orienter les **clips (BYT)** comme illustré dans cette image, et insérer-les dans les emplacements indiqués.
- Colocar el panel de tejado sobre la fachada de entrada, panel mural, y la cercha. Orientar los **clips (BYT)** como se muestra en esta imagen, e insertarlos en las ubicaciones indicadas.

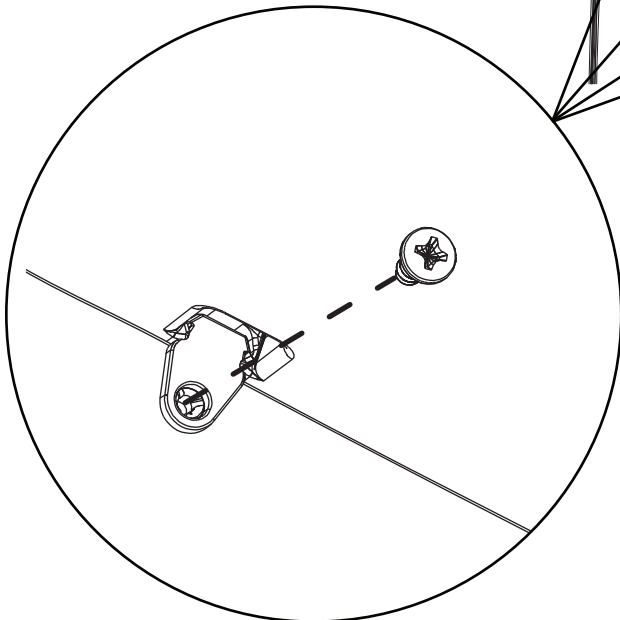
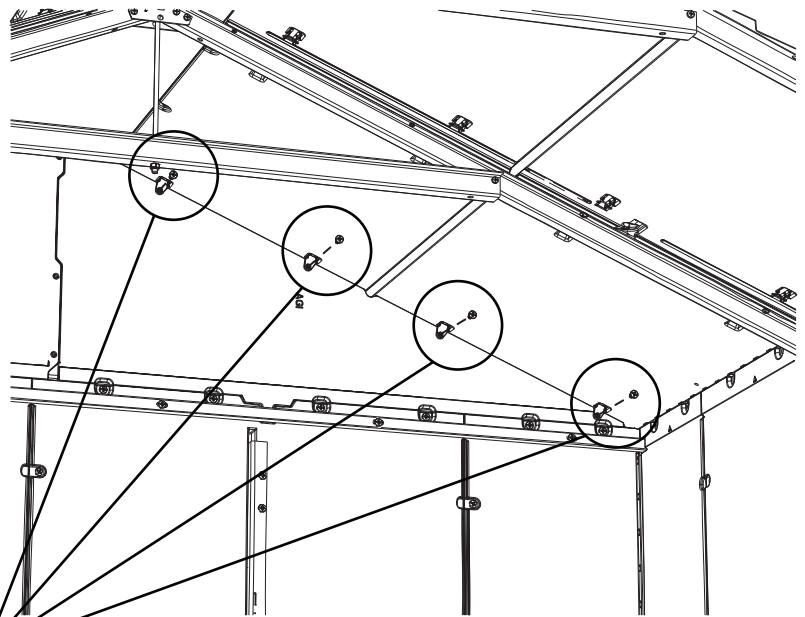
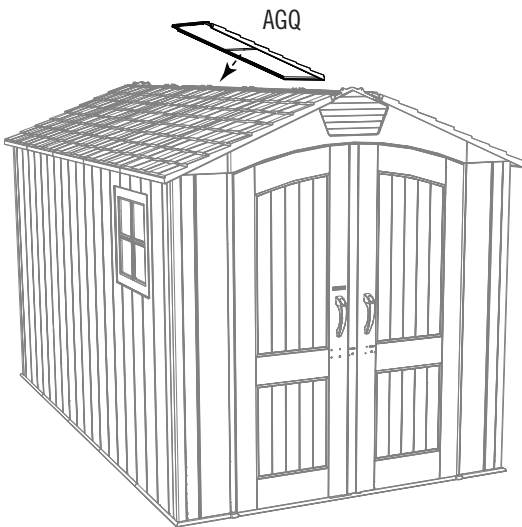

► SECTION 10 (CONTINUED) / SECTION 10 (SUITE) / SECCIÓN 10 (CONTINUACIÓN)

TOOLS AND HARDWARE REQUIRED / OUTILS ET QUINCAILLERIE REQUIS / INSTRUMENTAL Y HERRAJE REQUERIDOS

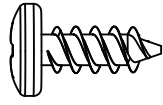

ADZ (x4)

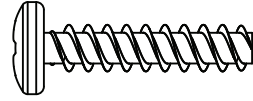

ADV (x4)

10.23

- Insert four (4) long **Screws (ADV)** along the top edge of the Wall Panel and four (4) short **Screws (ADZ)** along the Truss as shown. **Only insert the long Screws (ADV) along the top edge of the Wall Panel.**
- Insérer quatre (4) **vis (ADV)** le long du bord supérieur du panneau mural et quatre (4) **vis (ADZ)** courtes à travers la ferme comme illustré. **N'insérer les vis (ADV) courtes que le long du bord supérieur du panneau mural.**
- Insertar cuatro (4) **tornillos (ADV)** largos a lo largo del borde superior del panel mural y cuatro (4) **tornillos (ADZ)** cortos a través de la cercha se muestra. **Insertar los tornillos (ADV) largos sólo a lo largo del borde superior del panel mural.**

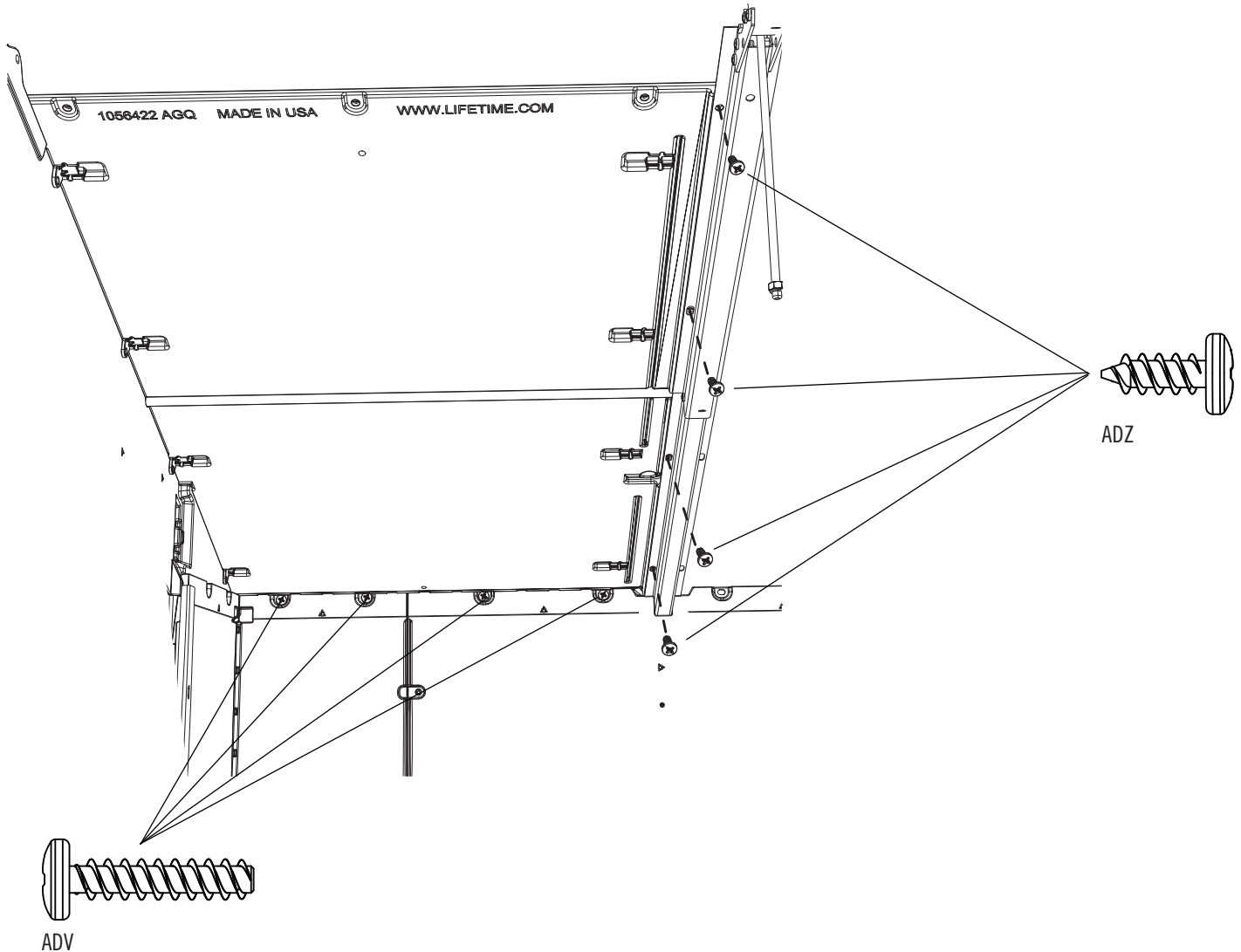

► SECTION 10 (CONTINUED) / SECTION 10 (SUITE) / SECCIÓN 10 (CONTINUACIÓN)

TOOLS AND HARDWARE REQUIRED / OUTILS ET QUINCAILLERIE REQUIS / INSTRUMENTAL Y HERRAJE REQUERIDOS



10.24

- Insert two (2) pieces of **Foam (BYX)** into each **End Cap (BYW)** as shown. **Repeat this step for the second End Caps.**
- Insérer deux (2) pièces de **mousse (BYX)** dans chaque **capuchon (BYW)** comme illustré. **Répéter cette étape pour le deuxième capuchon.**
- Insertar dos (2) piezas de **espuma (BYX)** en cada **tapón (BYW)** como se muestra. **Repetir este paso para el segundo tapón.**

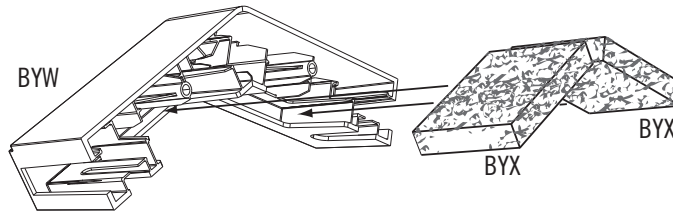

10.25

- Insert the two (2) pieces of **Skylight (BYV and FYV)** into the **Connector (FRW)** as shown.
- Insérer les deux (2) pièces de **lucarne (BYV et FYV)** dans le **connecteur (FRW)** comme illustré.
- Insertar las dos (2) piezas de **tragaluz (BYV y FYV)** en el **conector (FRW)** como se muestra.

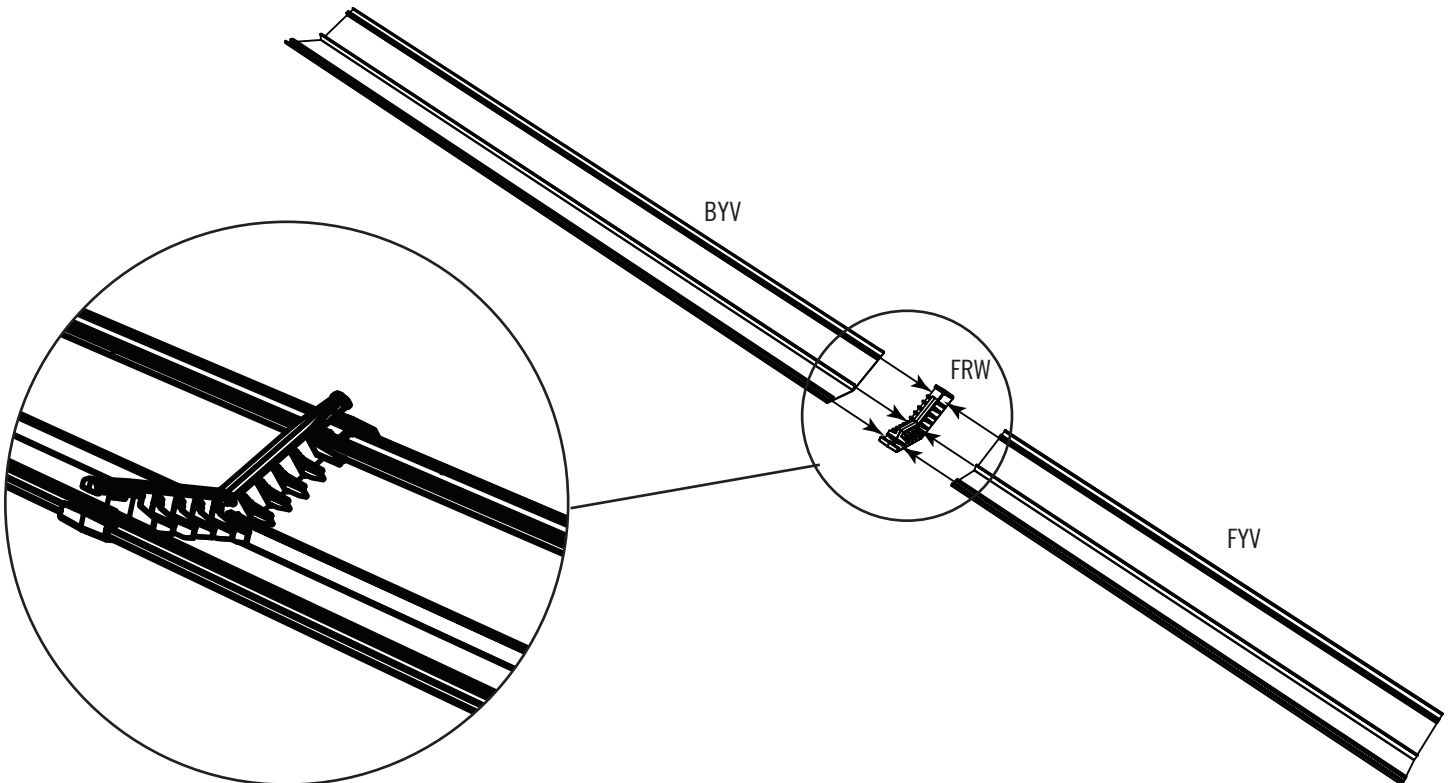

► SECTION 10 (CONTINUED) / SECTION 10 (SUITE) / SECCIÓN 10 (CONTINUACIÓN)

TOOLS AND HARDWARE REQUIRED / OUTILS ET QUINCAILLERIE REQUIS / INSTRUMENTAL Y HERRAJE REQUERIDOS

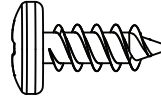

ADZ (x4)

10.26

- Connect the End Cap to the end of the Skylight, and use two (2) **Screws (ADZ)** to secure it to the outside of the shed.
- Fixer le capuchon à l'extrémité de la lucarne, et employer deux (2) **vis (ADZ)** pour le fixer à l'extérieur de l'abri.
- Fijar el tapón al extremo del tragaluz, et usar dos (2) **tornillos (ADZ)** para fijarlo al exterior de la caseta.

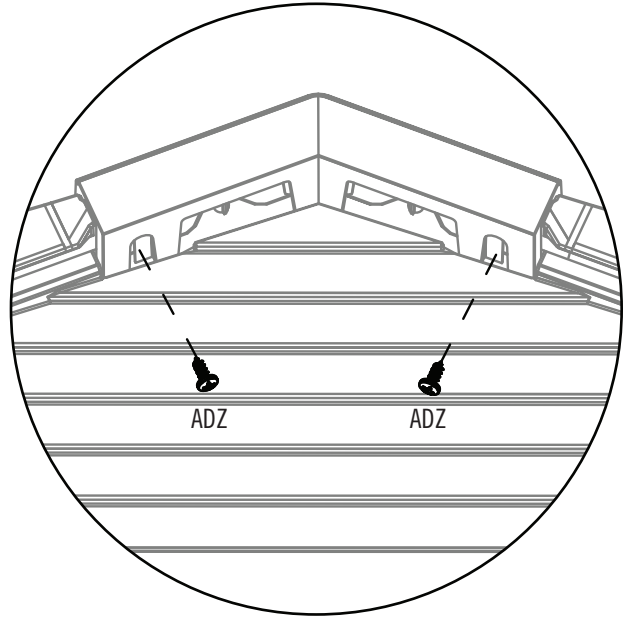
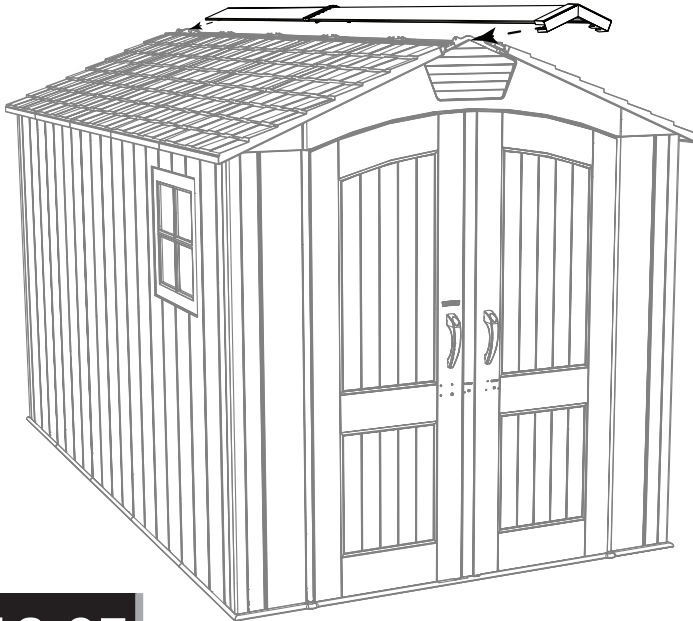

10.27

- Connect the End Cap to the inside of the shed using two (2) **Screws (ADZ)**.
- Fixer le capuchon à l'intérieur de l'abri à l'aide de deux (2) **vis (ADZ)**.
- Fijar el tapón al interior de la caseta usando dos (2) **tornillos (ADZ)**.

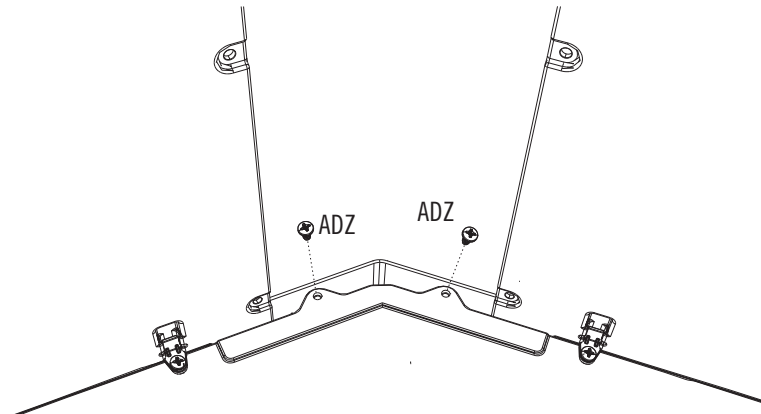

► SECTION 10 (CONTINUED) / SECTION 10 (SUITE) / SECCIÓN 10 (CONTINUACIÓN)

TOOLS AND HARDWARE REQUIRED / OUTILS ET QUINCAILLERIE REQUIS / INSTRUMENTAL Y HERRAJE REQUERIDOS

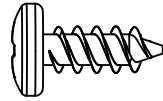

ADZ (x30)

10.28



- Use a hand screwdriver to connect the Skylight to the Roof Panels using thirty (30) **Screws (ADZ)**.
- Employer un tournevis pour fixer la lucarne aux panneaux de toit à l'aide de trente (30) **vis (ADZ)**.
- Usar un destornillador para fijar el tragaluz a los paneles de tejado usando treinta (30) **tornillos (ADZ)**.

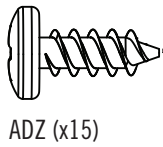

ADZ (x15)

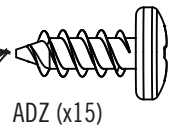
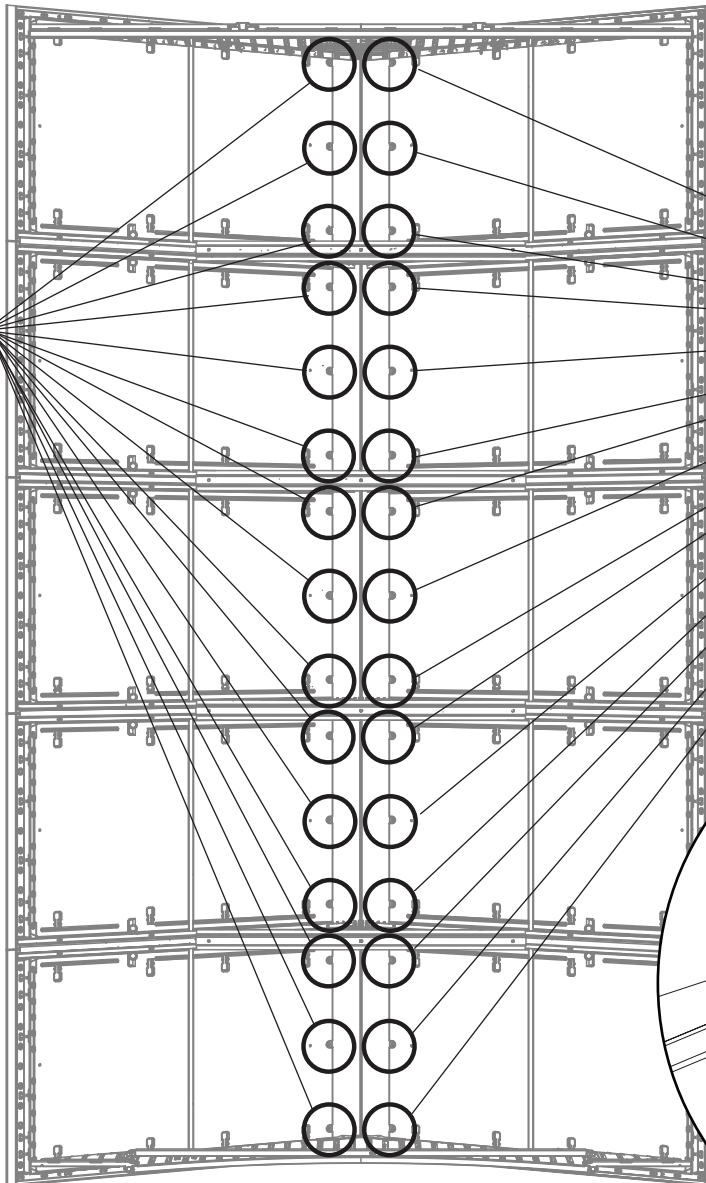

ADZ (x15)

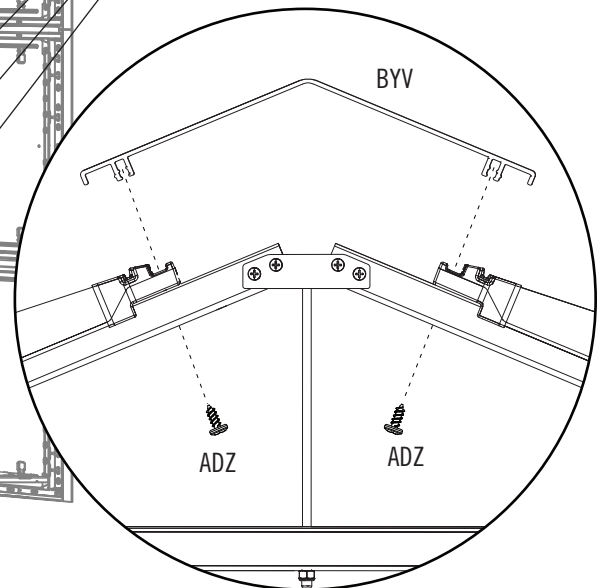

► SECTION 10 (CONTINUED) / SECTION 10 (SUITE) / SECCIÓN 10 (CONTINUACIÓN)

TOOLS AND HARDWARE REQUIRED / OUTILS ET QUINCAILLERIE REQUIS / INSTRUMENTAL Y HERRAJE REQUERIDOS

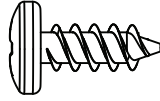

ADZ (x4)

10.29

- Connect the End Cap to the outside of the shed using two (2) **Screws (ADZ)**.
- Fixer le capuchon à l'extérieur de l'abri à l'aide de deux (2) **vis (ADZ)**.
- Fijar el tapón al exterior de la caseta usando dos (2) **tornillos (ADZ)**.

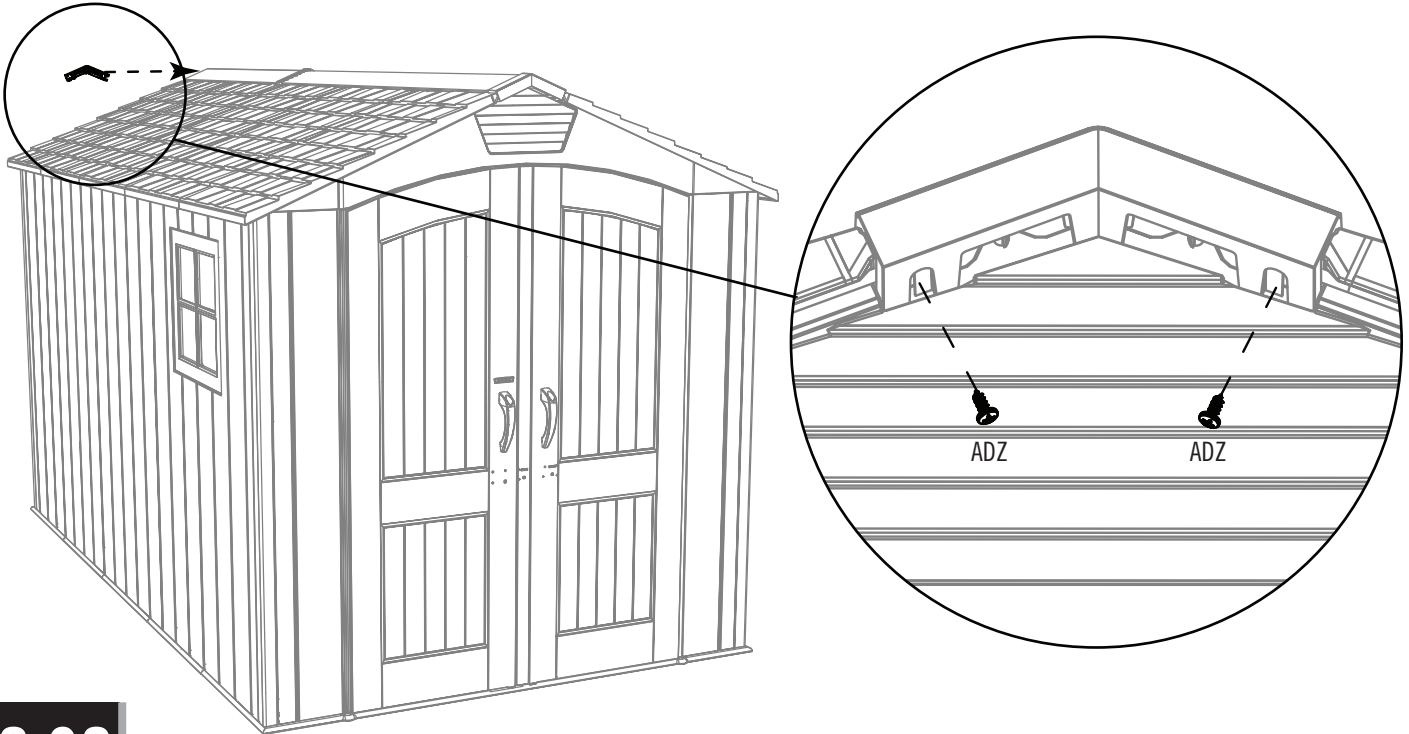

10.30

- Connect the End Cap to the inside of the shed using two (2) **Screws (ADZ)**.
- Fixer le capuchon à l'intérieur de l'abri à l'aide de deux (2) **vis (ADZ)**.
- Fijar el tapón al interior de la caseta usando dos (2) **tornillos (ADZ)**.

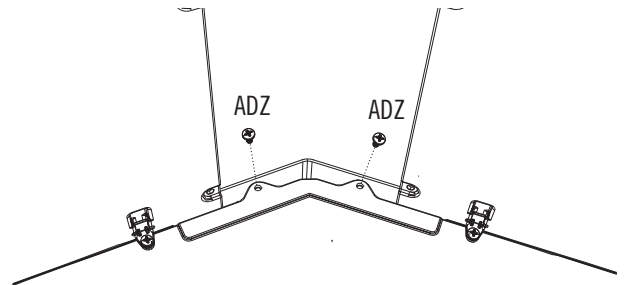

11

DOOR ALIGNMENT / ALIGNEMENT DES PORTES / ALINEACIÓN DE LAS PUERTAS



HARDWARE REQUIRED / HERRAJE REQUERIDO / QUINCAILLERIE REQUISE

Hardware Bag / Sac de quincaillerie / Bolsa de herraje



PARTS REQUIRED / PIÈCES REQUISES / PIEZAS REQUERIDAS

Plastic Parts / Pièces en plastique / Piezas de plástico

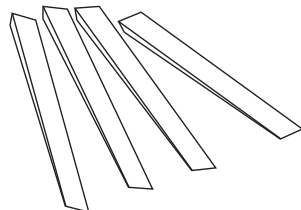

EUG (x4)



TOOLS REQUIRED / OUTILS REQUIS / INSTRUMENTAL REQUERIDO

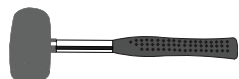

► SECTION 11 (CONTINUED) / SECTION 11 (SUITE) / SECCIÓN 11 (CONTINUACIÓN)

TOOLS AND HARDWARE REQUIRED / OUTILS ET QUINCAILLERIE REQUIS / INSTRUMENTAL Y HERRAJE REQUERIDOS

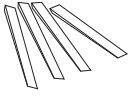

EUG (x4)



- If you have trouble with this section, follow the code below to view a how-to video for this section.
- En cas de problèmes avec cette section, suivre le code en bas pour voir un vidéo comment faire pour cette section.
- En caso de problemas con esta sección, seguir el código debajo para ver un video «cómo» para esta sección.



<http://go.lifetime.com/dooralignment7>

11.1

- If the Doors are not level, follow the steps on the next page to even them out.
- Si les portes ne sont pas niveaux l'une avec l'autre, suivre les étapes sur la page suivante pour les niveler.
- Si las puertas no son niveles, seguir los pasos en la página siguiente para nivelarlas.

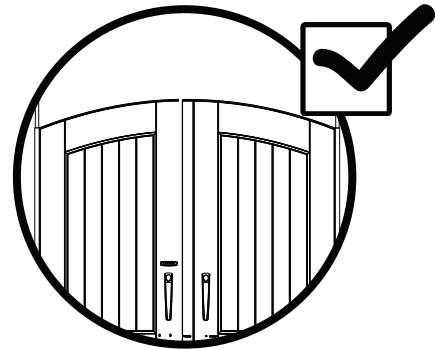

► SECTION 11 (CONTINUED) / SECTION 11 (SUITE) / SECCIÓN 11 (CONTINUACIÓN)

TOOLS AND HARDWARE REQUIRED / OUTILS ET QUINCAILLERIE REQUIS / INSTRUMENTAL Y HERRAJE REQUERIDOS

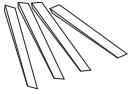

EUG (x4)



11.2

- If the Left Door is higher, insert a shim underneath the Floor and right Hinge Tube until the two Doors are level.
- Si la porte gauche est plus haute, insérer une cale sous le plancher et la charnière de la porte droite jusqu'à ce que les deux portes soient de niveau.
- Si la puerta izquierda es más alta, insertar una cuña debajo el piso y la bisagra derecha hasta que las dos puertas estén al mismo nivel.

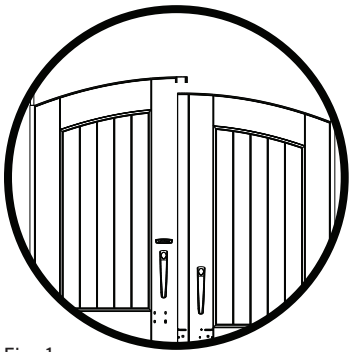

Fig. 1

+

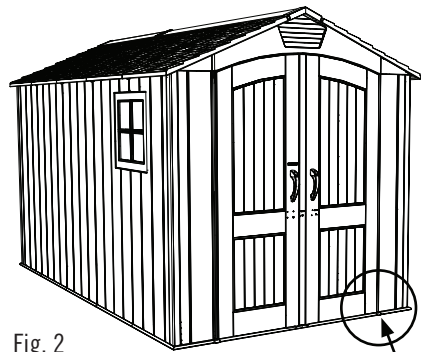

Fig. 2

=

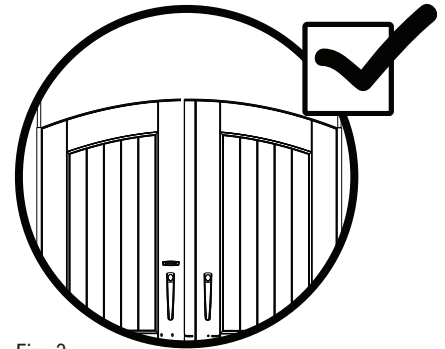

Fig. 3

11.3

- If the Right Door is higher, insert a shim underneath the Floor and left Hinge Tube until the two Doors are level.
- Si la porte droite est plus haute, insérer une cale sous le plancher et la charnière de la porte gauche jusqu'à ce que les deux portes soient de niveau.
- Si la puerta derecha es más alta, insertar una cuña debajo el piso y la bisagra izquierda hasta que las dos puertas estén al mismo nivel.

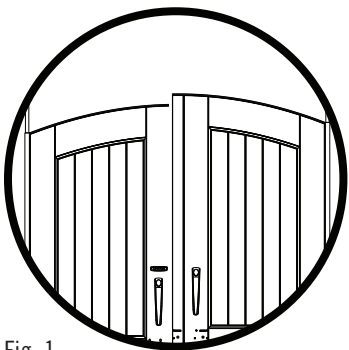
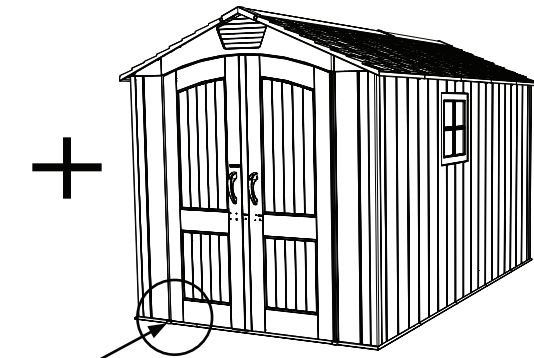

Fig. 1

+



EUG

Fig. 2

=

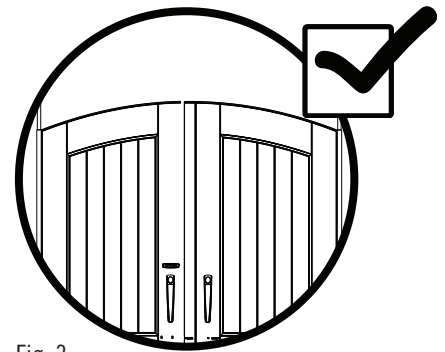

Fig. 3



HARDWARE REQUIRED / QUINCAILLERIE REQUISE / HERRAJE REQUERIDO

*NO HARDWARE INCLUDED FOR THIS SECTION
AUCUNE QUINCAILLERIE INCLUSE POUR CETTE SECTION
NINGÚN HERRAJE INCLUIDO PARA ESTA SECCIÓN*



PARTS REQUIRED / PIÈCES REQUISES / PIEZAS REQUERIDAS

*NO PARTS REQUIRED FOR THIS SECTION
AUCUNE PIÈCE REQUISE POUR CETTE SECTION
NINGUNA PIEZA REQUERIDA PARA ESTA SECCIÓN*



TOOLS REQUIRED / OUTILS REQUIS / INSTRUMENTAL REQUERIDO

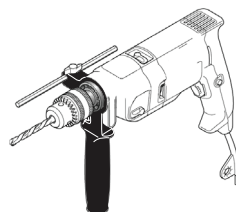
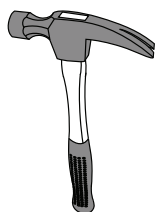



5/16" (8 mm) Wood Drill Bit
8 mm Foret à bois
8 mm Broca para madera

5/16" (8 mm) Masonry Drill Bit
8 mm Foret à maçonnerie
8 mm Broca para albañilería

► SECTION 12 (CONTINUED) / SECTION 12 (SUITE) / SECCIÓN 12 (CONTINUACIÓN)

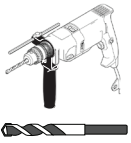
TOOLS AND HARDWARE REQUIRED / OUTILS ET QUINCAILLERIE REQUIS / INSTRUMENTAL Y HERRAJE REQUERIDOS



5/16 in/po
(8 mm)



12.1



• To anchor your shed, you must purchase the correct anchoring hardware. **For a concrete platform**, we recommend using a hammer drill, 5/16" (8 mm) masonry bit, four (4) 3/8" x 2" (10 mm x 5 cm) Concrete Screws and four (4) 3/8" x 1" (10 mm x 2,5 cm) Fender Washers. **Do not exceed a 3/8" (10 mm) diameter screw. Refer to your local hardware store for this hardware.**

• Pour ancrer l'abri, il faut acheter la quincaillerie d'ancrage correcte. **Pour une plate-forme en béton**, nous recommandons que vous utilisiez une perceuse de percussion, un foret à maçonnerie de 8 mm (5/16 po), quatre (4) Vis d'ancrage à béton de 10 mm x 5 cm (3/8 po x 2 po) et quatre (4) Rondelles de protection de 10 mm x 2,5 cm (3/8 po x 1 po). **Ne dépassez pas de diamètre de 10 mm (3/8 po). Votre quincaillerie du coin aura ces accessoires.**

• Para anclar la caseta, es necesario comprar el herraje de anclaje correcto. **Para una plataforma de concreto**, recomendamos que use un martillo perforador, broca de albañilería de 8 mm (5/16 in), cuatro (4) Tornillos de anclaje para concreto de 10 mm x 5 cm (3/8 in x 2 in) y cuatro (4) Rondanas de protección de 10 mm x 2,5 cm (3/8 in x 1 in). **No exceda un diámetro de 10 mm (3/8 in). Refiérase a su ferretería local para obtener este herraje.**

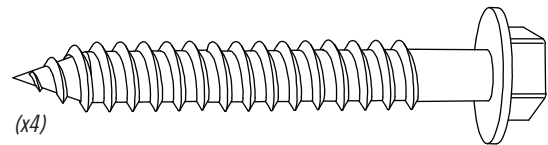
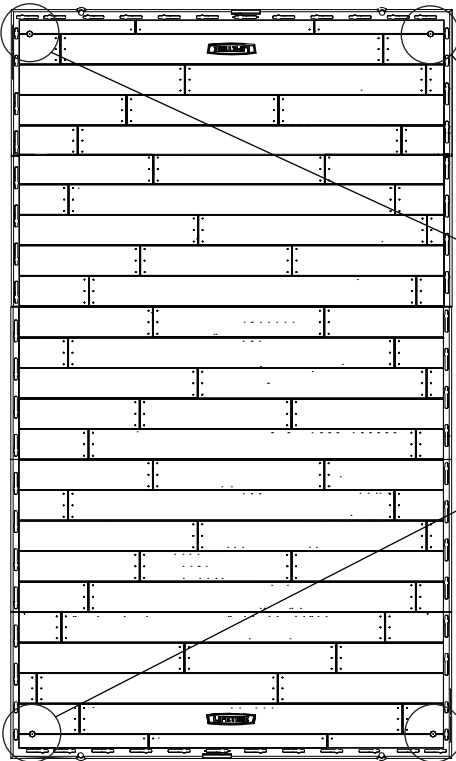

(x4)

(Not included) (Pas incluses) (No incluidas)

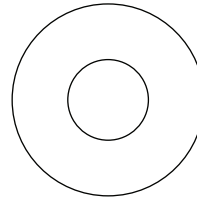

(x4)

(Not included) (Pas incluses) (No incluidas)



WARNING / AVERTISSEMENT / ADVERTENCIA



- Failure to anchor the shed may result in property damage and/or personal injury.
- Si vous n'ancrez pas votre abri, des dommages à la propriété et/ou des blessures peuvent en résulter.
- No anclar la caseta puede resultar en daños a la propiedad y/o en lesiones personales.

▶ SECTION 12 (CONTINUED) / SECTION 12 (SUITE) / SECCIÓN 12 (CONTINUACIÓN)

TOOLS AND HARDWARE REQUIRED / OUTILS ET QUINCAILLERIE REQUIS / INSTRUMENTAL Y HERRAJE REQUERIDOS



5/16 in/po
(8 mm)



12.1



• To anchor your shed, you must purchase the correct anchoring hardware. **For a wood-framed platform**, we recommend using a drill, 5/16" (8 mm) drill bit, four (4) 3/8" x 1 1/2" (10 mm x 4 cm) Lag Screws and four (4) 3/8" x 1" (10 mm x 2,5 cm) Fender Washers. **Do not exceed a 3/8" (10 mm) diameter screw. Refer to your local hardware store for this hardware.**

• Pour ancrer l'abri, il faut acheter la quincaillerie d'ancrage correcte. **Pour une plate-forme en bois**, nous recommandons que vous utilisiez une perceuse électrique, un foret de 8 mm (5/16 po), quatre (4) vis de retard de 10 mm x 4 cm (3/8 po x 1 1/2 po), et quatre (4) rondelles de protection de 10 mm x 2,5 cm (3/8 po x 1 po). **Ne dépassez pas de diamètre de 10 mm (3/8 po). Votre quincaillerie du coin aura ces accessoires.**

• Para anclar la caseta, es necesario comprar el herraje de anclaje correcto. **Para una plataforma hecho de hecho de madera**, recomendamos que use un taladro eléctrico, una broca de 8 mm (5/16 in), cuatro (4) Tornillos para madera de 10 mm x 4 cm (3/8 in x 1 1/2 in) y cuatro (4) Rondanas de protección de 10 mm x 2,5 cm (3/8 in x 1 in). **No exceda un diámetro de 10 mm (3/8 in). Refiérase a su ferretería local para obtener este herraje.**

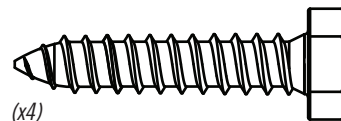
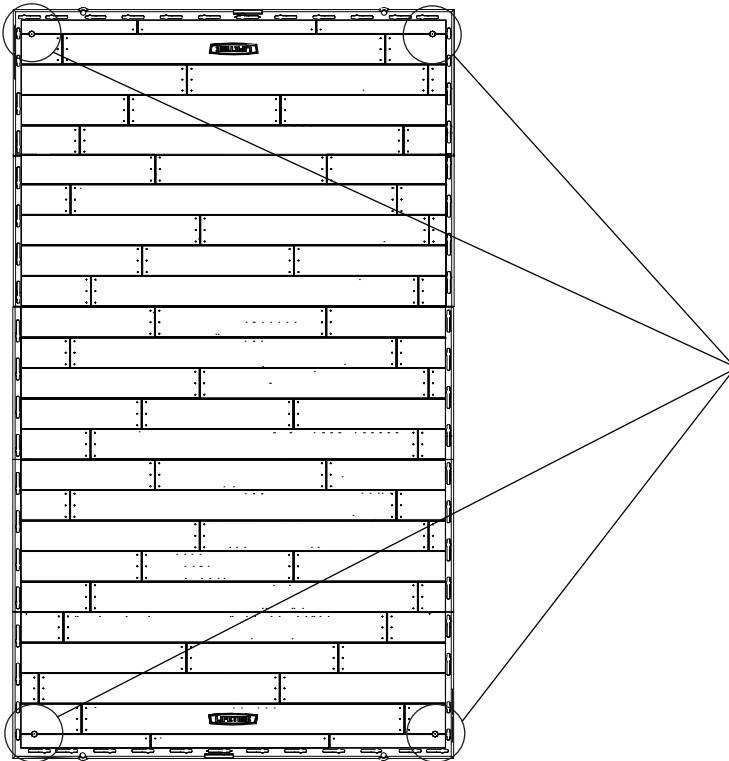

(x4)

(Not included) (Pas incluses) (No incluidas)

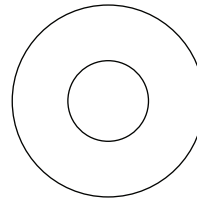

(x4)

(Not included) (Pas incluses) (No incluidas)



WARNING / AVERTISSEMENT / ADVERTENCIA



- Failure to anchor the shed may result in property damage and/or personal injury.
- Si vous n'ancrez pas votre abri, des dommages à la propriété et/ou des blessures peuvent en résulter.
- No anclar la caseta puede resultar en daños a la propiedad y/o en lesiones personales.



HARDWARE REQUIRED / QUINCAILLERIE REQUISE / HERRAJE REQUERIDO

Hardware Bag / Sac de quincaillerie / Bolsa de herraje

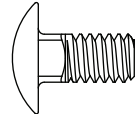

ACA (x3)

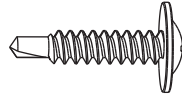

CHK (x2)

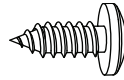

ADX (x9)



CVR (x1)

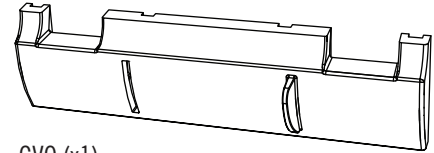

CVQ (x1)

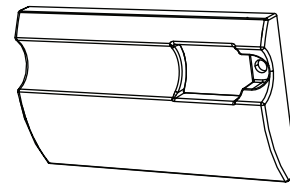

CVS (x1)



AEB (x3)

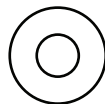

AEE (x9)

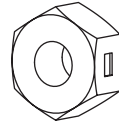

AAB (x3)

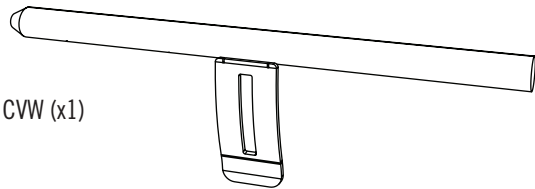

CVW (x1)

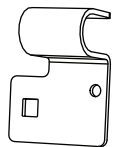

CVT (x1)



CVU (x1)



CVV (x1)



TOOLS REQUIRED / OUTILS REQUIS / INSTRUMENTAL REQUERIDO



7/16 in/po (11 mm)



► SECTION 13 (CONTINUED) / SECTION 13 (SUITE) / SECCIÓN 13 (CONTINUACIÓN)

TOOLS AND HARDWARE REQUIRED / OUTILS ET QUINCAILLERIE REQUIS / INSTRUMENTAL Y HERRAJE REQUERIDOS

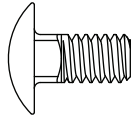

ACA (x1)

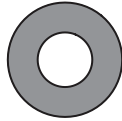

AEB (x1)

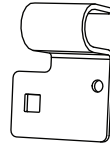

CVT (x1)

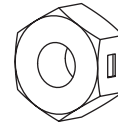

AAB (x1)

13.1

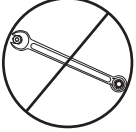

- Only after following the anchoring instructions, attach the **Left Latch Bracket (CVT)** to the Left Door using the hardware provided. **Only hand tighten the Nut at this point.**
- Seulement après avoir ancré votre abri, attacher le **support gauche du loquet (CVT)** à la porte gauche à l'aide de la quincaillerie incluse. **Ne serrer l'écrou que pour la main en ce moment.**
- Sólo después de haber seguido los pasos de anclaje, sujetar el **soporte izquierdo del pestillo (CVT)** a la puerta izquierda usando el herraje incluido. **Sólo apretar la tuerca a mano en este momento.**

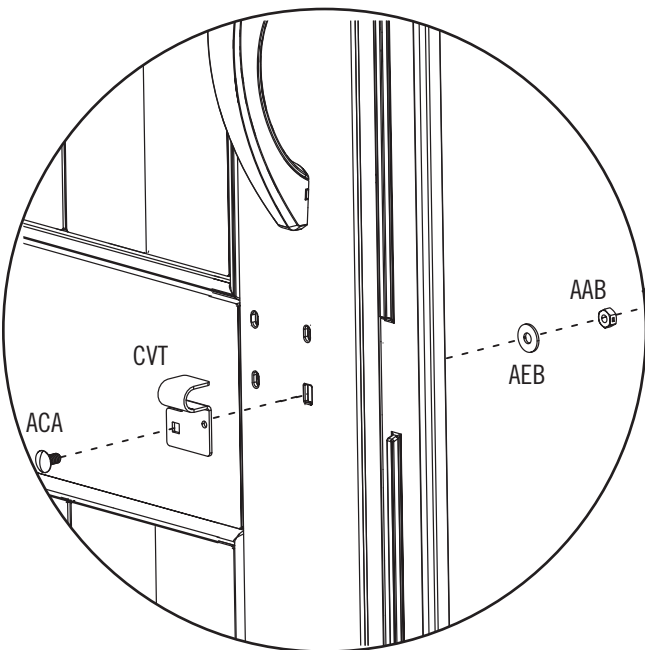
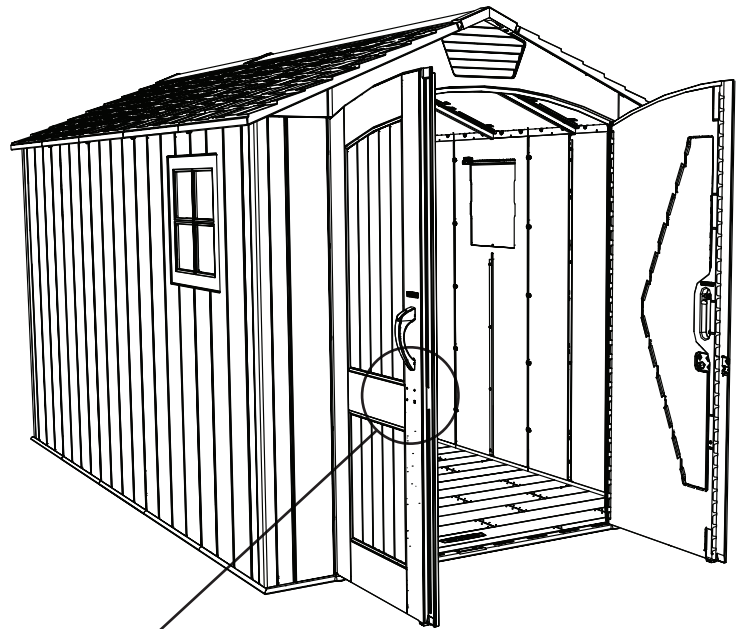

► SECTION 13 (CONTINUED) / SECTION 13 (SUITE) / SECCIÓN 13 (CONTINUACIÓN)

TOOLS AND HARDWARE REQUIRED / OUTILS ET QUINCAILLERIE REQUIS / INSTRUMENTAL Y HERRAJE REQUERIDOS



7/16 in/po
(11 mm)

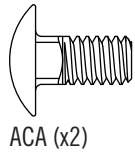

ACA (x2)

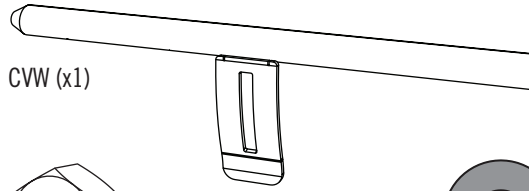

CVW (x1)

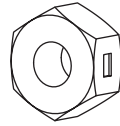

AAB (x2)



AEB (x2)

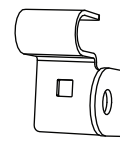

CVU (x1)

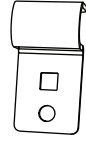

CVV (x1)

13.2

- Slide the **Large Right Latch Bracket (CVU)** and **Small Right Latch Bracket (CVV)** onto the **Latch (CVW)** as shown.
- Faire glisser le **support droit grand du loquet (CVU)** et le **support droit petit du loquet (CVV)** sur le **loquet (CVW)** comme illustré.
- Deslizar el **soporte derecho grande del pestillo (CVU)** y el **soporte derecho pequeño del pestillo (CVV)** en el **pestillo (CVW)** como se muestra.

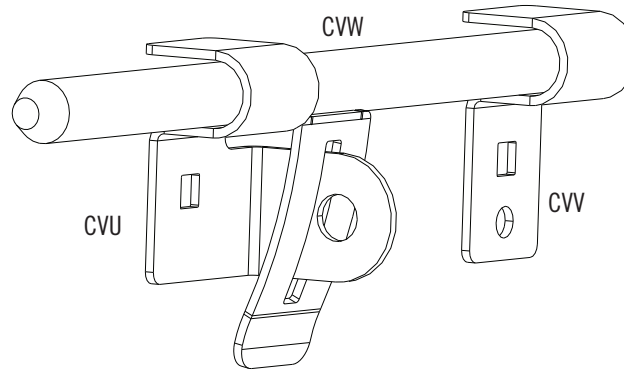

13.3

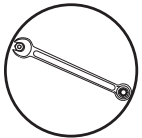

- Attach the Latch Assembly to the Right Door using the hardware provided. **Tighten these Nuts securely.**
- Attacher l'ensemble du loquet à la porte droite à l'aide de la quincaillerie incluse. **Serrer bien ces écrous.**
- Sujetar el conjunto del pestillo a la puerta derecha usando el herraje incluido. **Apretar bien estas tuercas.**

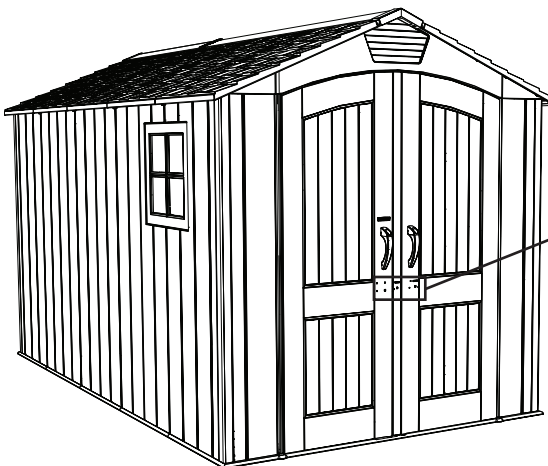
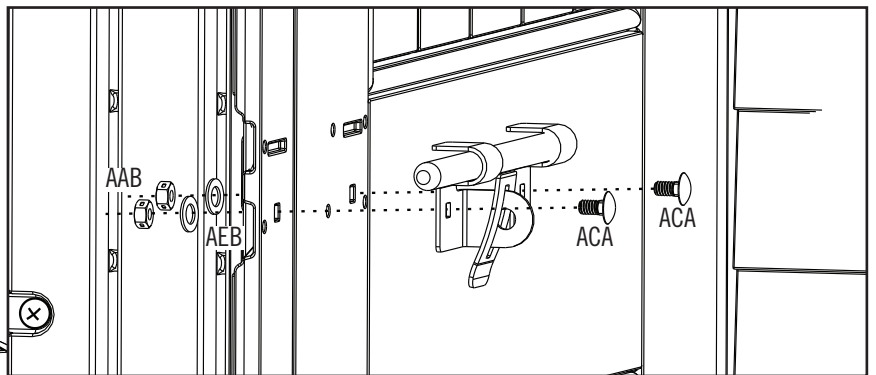

► SECTION 13 (CONTINUED) / SECTION 13 (SUITE) / SECCIÓN 13 (CONTINUACIÓN)

TOOLS AND HARDWARE REQUIRED / OUTILS ET QUINCAILLERIE REQUIS / INSTRUMENTAL Y HERRAJE REQUERIDOS

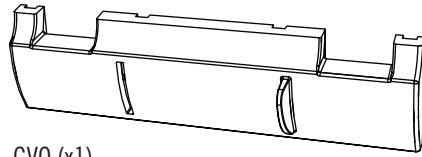

CVQ (x1)

13.4

- Slide the **Large Right Cover Plate (CVQ)** up under the Latch Assembly, and rotate the Latch downward to its locked position as shown.
- Faire glisser la **plaque couvrante grande droite (CVQ)** sous l'ensemble du loquet, et tourner l'ensemble à sa position de verrouillage comme illustré.
- Deslizar la **placa cubrepestillo grande derecha (CVQ)** debajo el conjunto del pestillo, y girar el pestillo en la posición de cierre como se muestra.

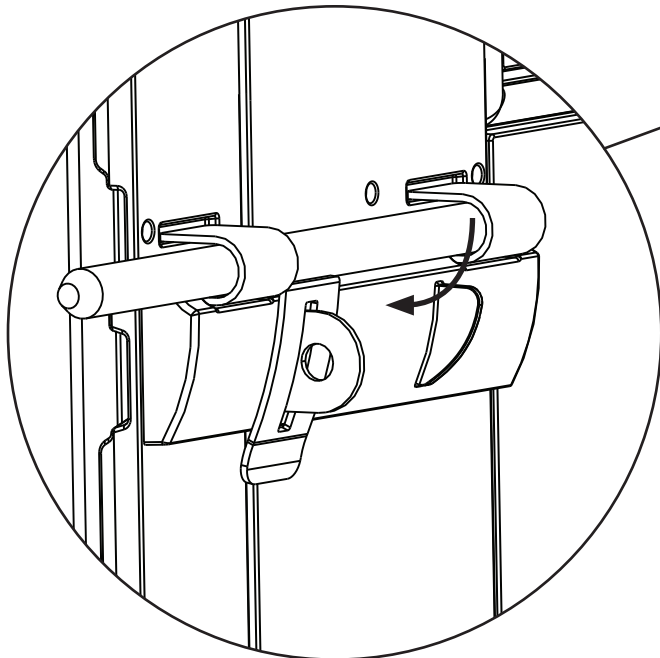
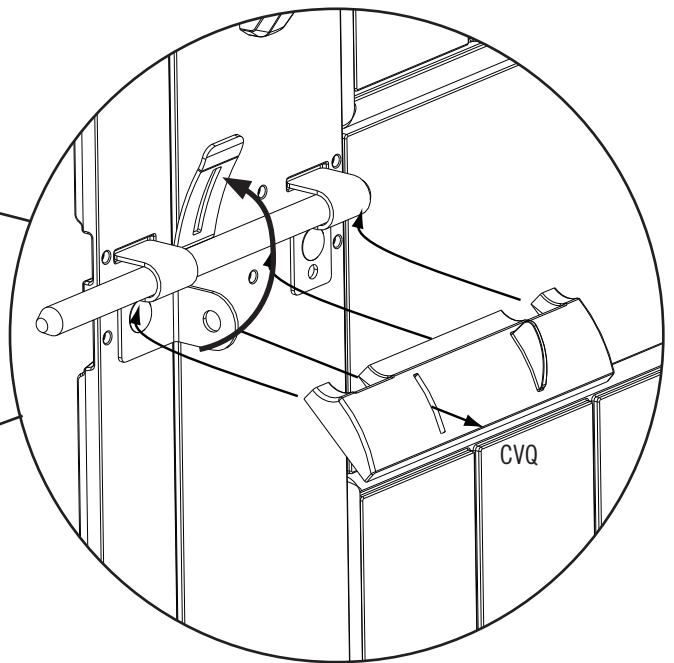
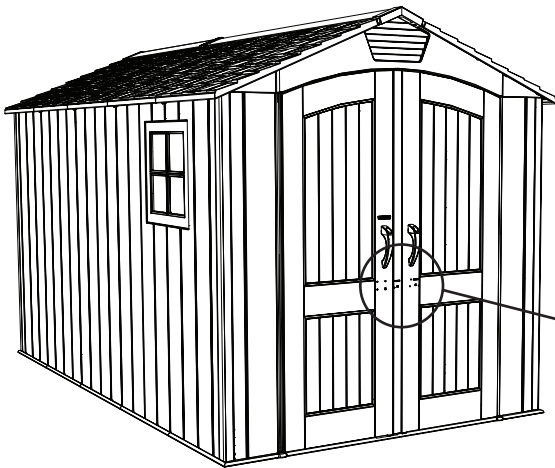

► SECTION 13 (CONTINUED) / SECTION 13 (SUITE) / SECCIÓN 13 (CONTINUACIÓN)

TOOLS AND HARDWARE REQUIRED / OUTILS ET QUINCAILLERIE REQUIS / INSTRUMENTAL Y HERRAJE REQUERIDOS

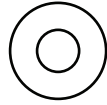

AEE (x3)

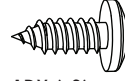

ADX (x3)

13.5

- Secure the Large Cover Plate to the Door as shown using the hardware provided.
- Attacher la plaque couvrante grande à la porte à l'aide de la quincaillerie incluse.
- Sujetar la placa cubrepestillo grande a la puerta usando el herraje incluido.

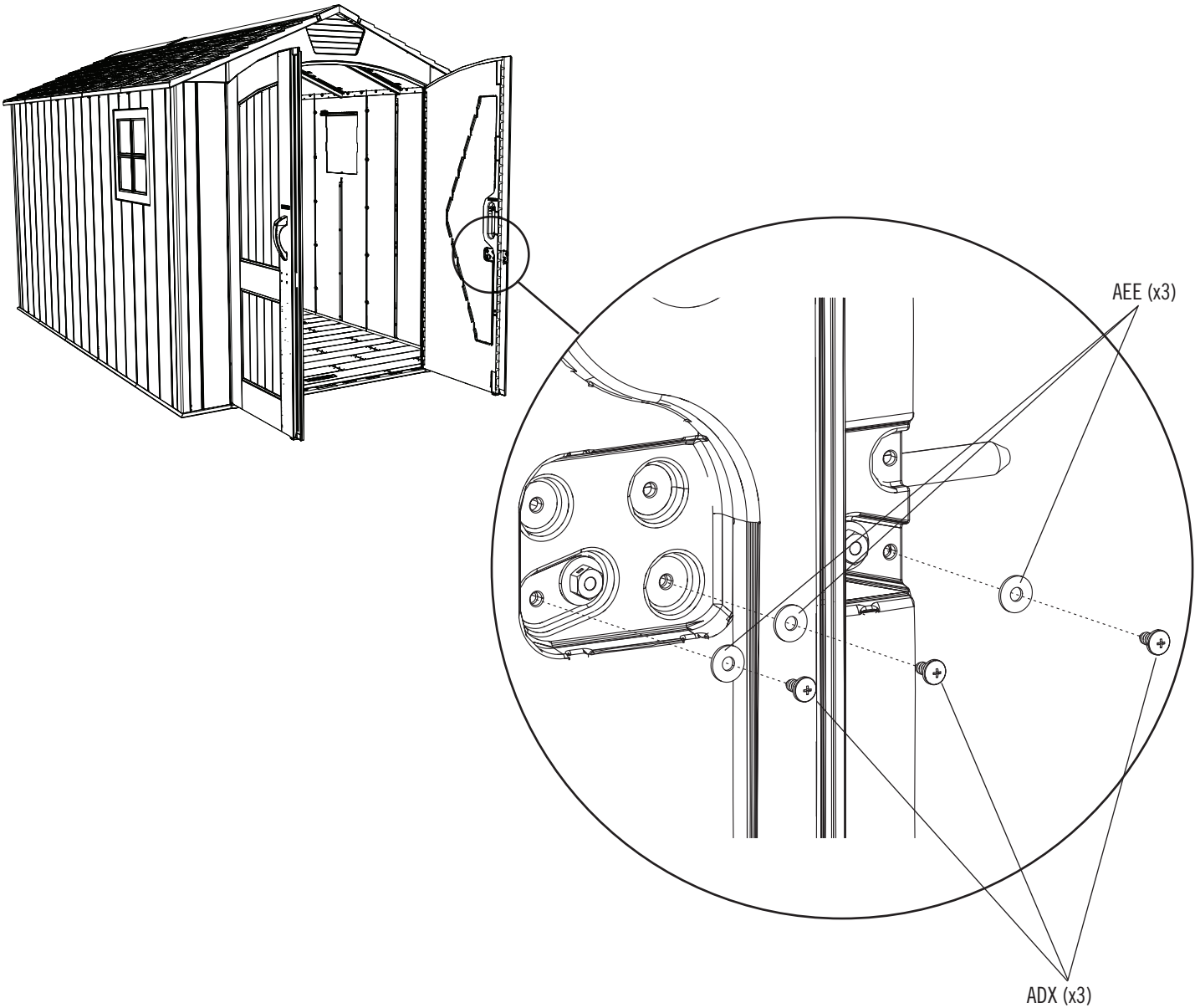

► SECTION 13 (CONTINUED) / SECTION 13 (SUITE) / SECCIÓN 13 (CONTINUACIÓN)

TOOLS AND HARDWARE REQUIRED / OUTILS ET QUINCAILLERIE REQUIS / INSTRUMENTAL Y HERRAJE REQUERIDOS



CVR (x1)

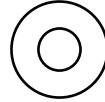

AEE (x3)

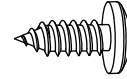

ADX (x3)

13.6

- Slide the **Small Right Cover Plate (CVR)** down under the Latch Assembly, and secure the Cover Plate to the Door as shown using the hardware provided.
- Faire glisser la **petite plaque couvrante droite (CVR)** sous l'ensemble du loquet, et attacher la plaque à la porte à l'aide de la quincaillerie incluse.
- Deslizar la **placa cubrepestillo pequeña derecha (CVR)** debajo el conjunto del pestillo, y sujetar la placa a la puerta usando el herraje incluido.

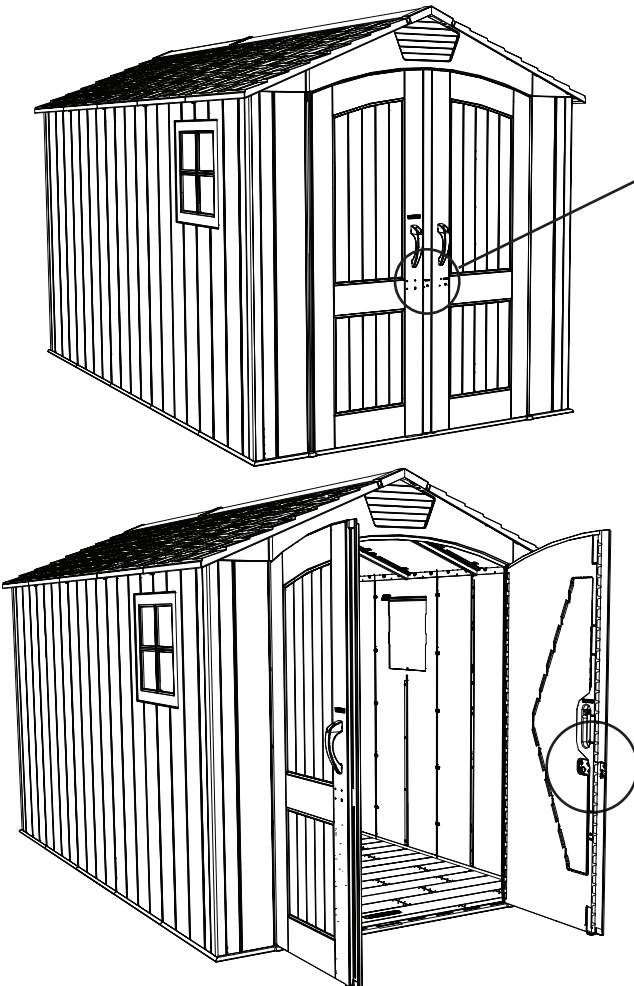
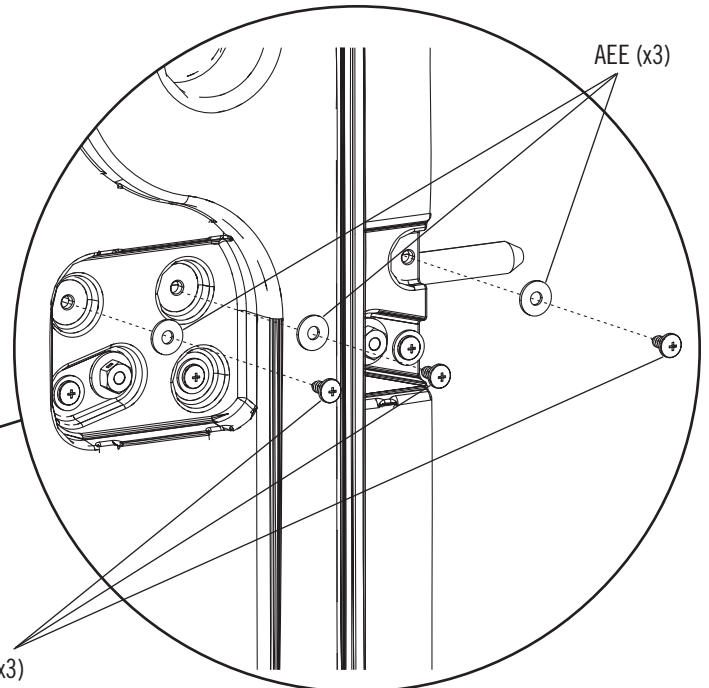
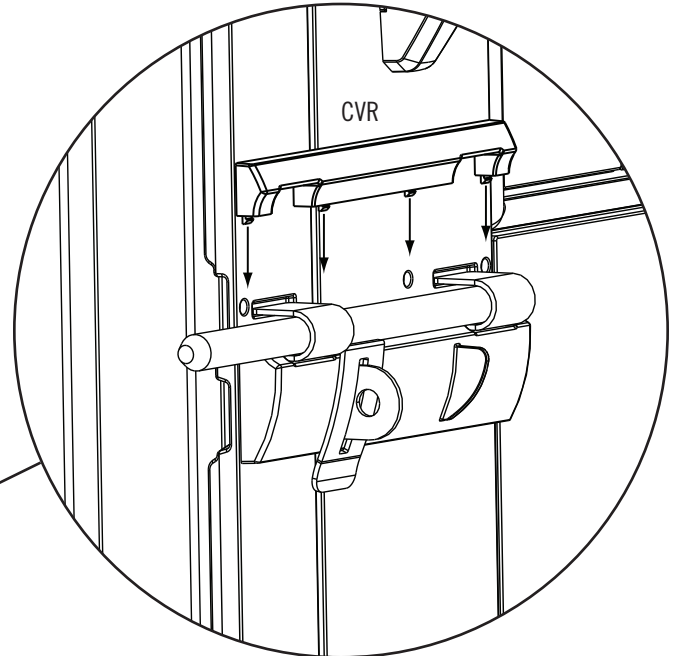

► SECTION 13 (CONTINUED) / SECTION 13 (SUITE) / SECCIÓN 13 (CONTINUACIÓN)

TOOLS AND HARDWARE REQUIRED / OUTILS ET QUINCAILLERIE REQUIS / INSTRUMENTAL Y HERRAJE REQUERIDOS

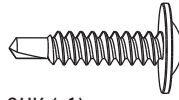

CHK (x1)

13.7

- Close both Doors and lock the Latch. Adjust the Left Latch Bracket so the Latch slides through freely.
- Fermer les deux portes et verrouillez le loquet. Ajuster le support gauche du loquet pour que le loquet verrouille librement.
- Cerrar las dos puertas y el pestillo. Ajustar el soporte izquierdo del pestillo para que el pestillo cierre libremente.

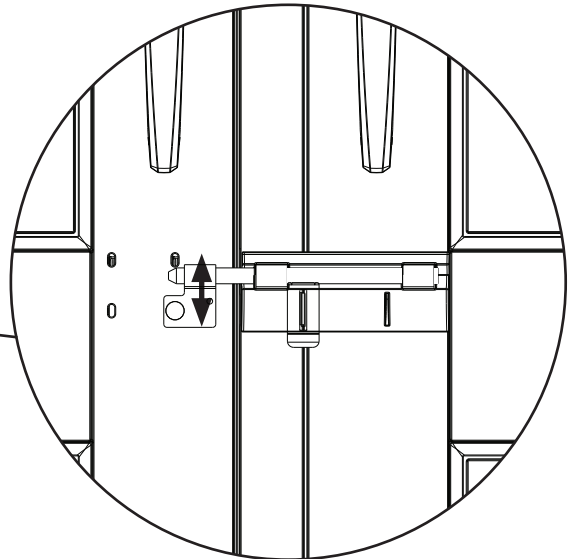
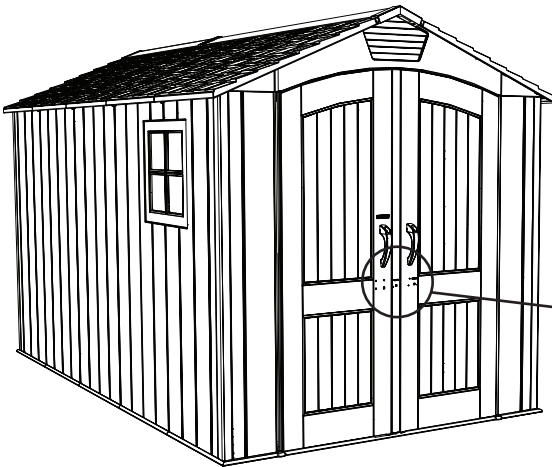

13.8

- Insert one (1) **Self-Drilling/Self-Tapping Screw (CHK)** through the hole in the Left Latch Bracket to secure it in place.
- Insérer une (1) **vis auto-perceuse/auto-taraudeuse (CHK)** à travers le trou dans le support gauche du loquet pour le fixer en place.
- Insertar un (1) **tornillo auto-perforante/auto-roscante (CHK)** a través del agujero en el soporte izquierdo del pestillo para fijarlo en su lugar.

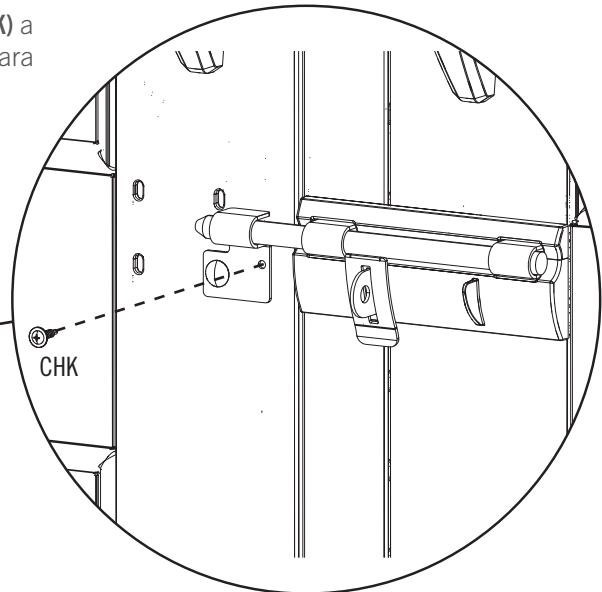
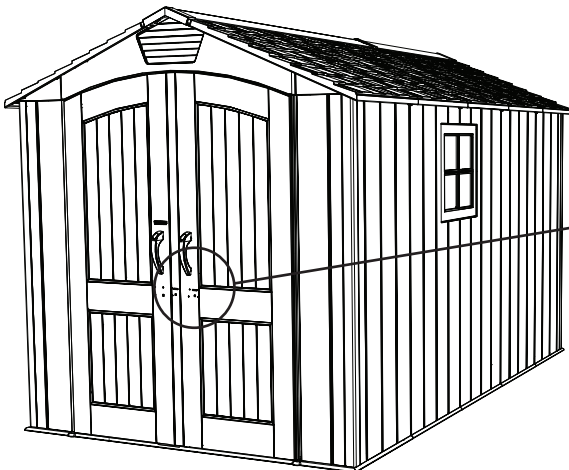

► SECTION 13 (CONTINUED) / SECTION 13 (SUITE) / SECCIÓN 13 (CONTINUACIÓN)

TOOLS AND HARDWARE REQUIRED / OUTILS ET QUINCAILLERIE REQUIS / INSTRUMENTAL Y HERRAJE REQUERIDOS



7/16 in/po
(11 mm)

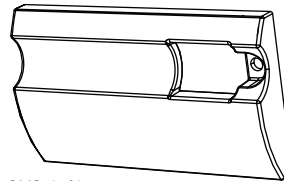

CVS (x1)

13.9

- Tighten the Nut to the Left Latch Bracket.
- Serrer bien l'écrou au support gauche du loquet.
- Apretar bien la tuerca al soporte izquierdo del pestillo.

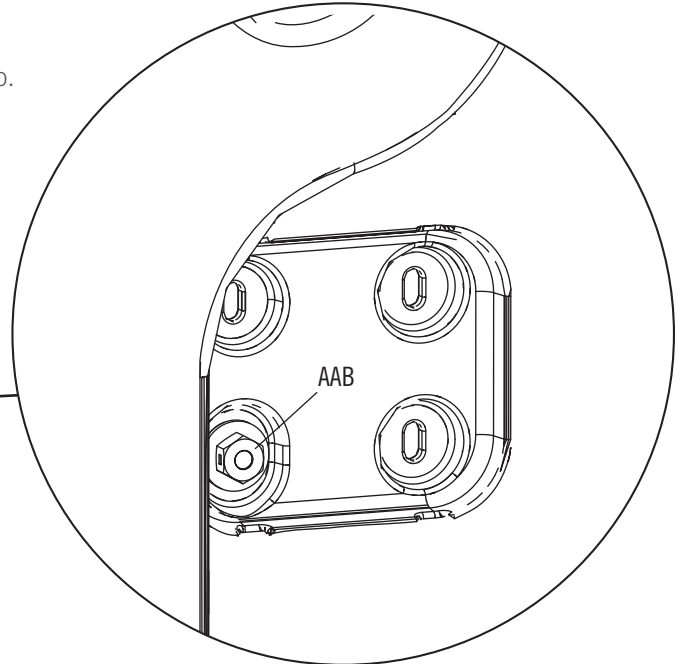
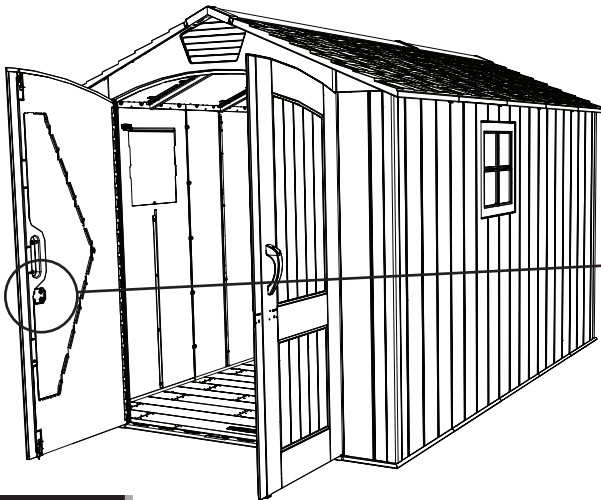

13.10

- Place **Left Cover Plate (CVS)** over the Left Latch Bracket.
- Mettre la **plaque couvrante gauche (CVS)** sur le support gauche du loquet.
- Colocar la **placa de cubierta izquierda (CVS)** encima del soporte izquierdo del pestillo.

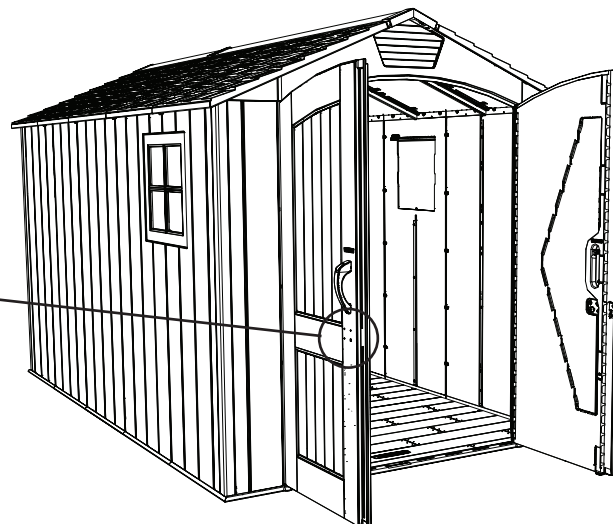
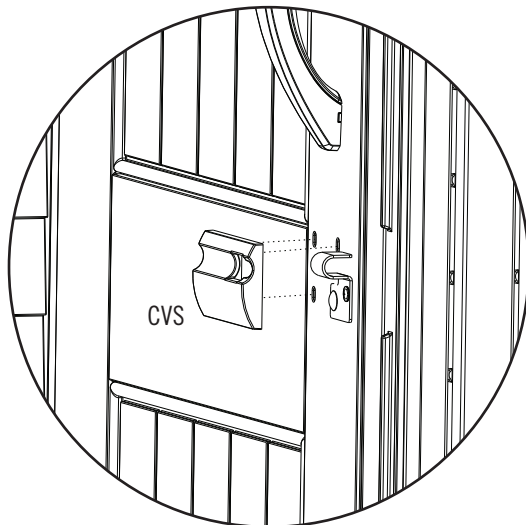

► SECTION 13 (CONTINUED) / SECTION 13 (SUITE) / SECCIÓN 13 (CONTINUACIÓN)

TOOLS AND HARDWARE REQUIRED / OUTILS ET QUINCAILLERIE REQUIS / INSTRUMENTAL Y HERRAJE REQUERIDOS

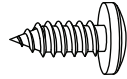

ADX (x3)

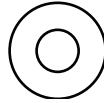

AEE (x3)

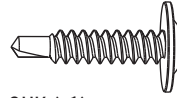

CHK (x1)

13.11

- Secure the Left Cover Plate to the Door as shown using the hardware provided.
- Attacher la plaque couvrante gauche à la porte à l'aide de la quincaillerie incluse.
- Sujetar la placa cubierta izquierda a la puerta usando el herraje incluido.

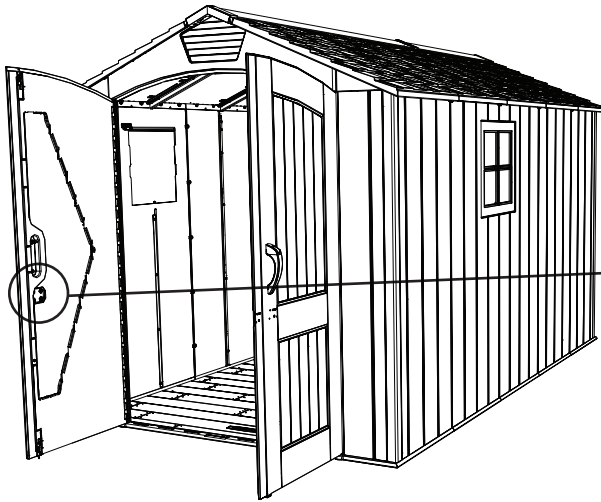

AEE (x3)

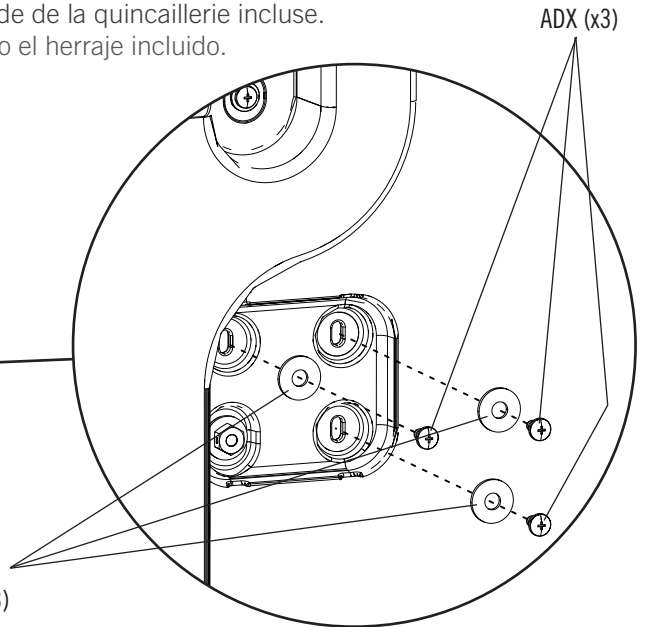

13.12

- Insert one (1) **Self-Drilling/Self-Tapping Screw (CHK)** through the hole in the Left Cover Plate to secure it in place.
- Insérer une (1) **vis auto-perceuse/auto-taraudeuse (CHK)** à travers le trou dans la plaque couvrante gauche pour la fixer en place.
- Insertar un (1) **tornillo auto-perforante/auto-roscante (CHK)** a través del agujero en la placa de cubierta izquierda para fijarla en su lugar.

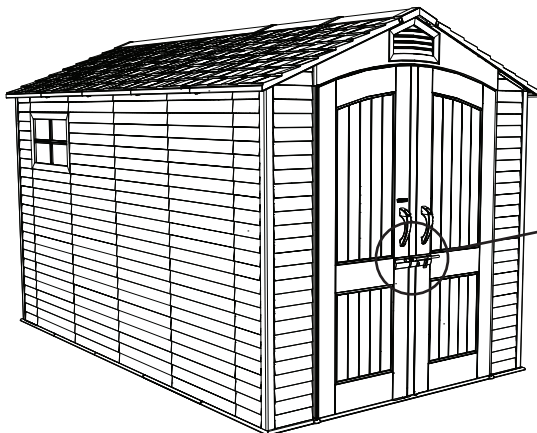

CHK

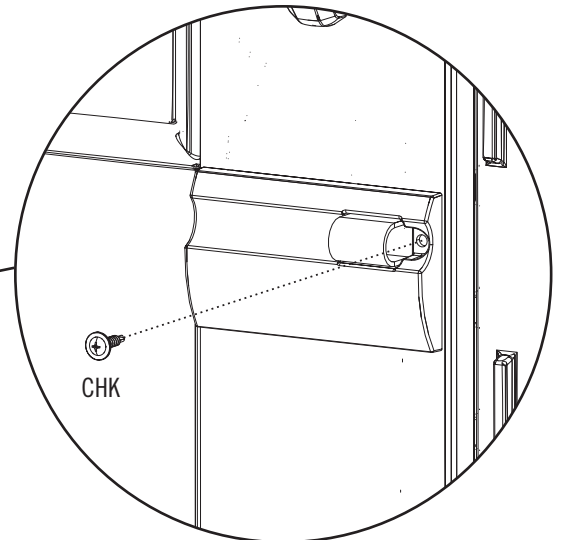



HARDWARE REQUIRED / QUINCAILLERIE REQUISE / HERRAJE REQUERIDO

Hardware Bag / Sac de quincaillerie / Bolsa de herraje

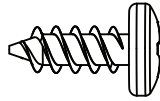
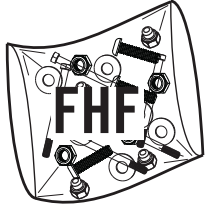

ADZ (x12)



PARTS REQUIRED / PIÈCES REQUISES / PIEZAS REQUERIDAS

Metal Parts / Pièces en métal / Piezas de metal



AIY (x2)



PARTS REQUIRED / PIÈCES REQUISES / PIEZAS REQUERIDAS

Plastic Parts / Pièces en plastique / Piezas de plástico

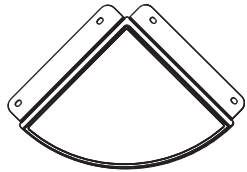

AFZ (x2)



AFS (x1)



TOOLS REQUIRED / OUTILS REQUIS / INSTRUMENTAL REQUERIDO



► SECTION 14 (CONTINUED) / SECTION 14 (SUITE) / SECCIÓN 14 (CONTINUACIÓN)

TOOLS AND HARDWARE REQUIRED / OUTILS ET QUINCAILLERIE REQUIS / INSTRUMENTAL Y HERRAJE REQUERIDOS

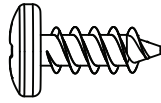

ADZ (x4)



AIY (x2)

14.1

- Insert two (2) **Shelf Brackets (AIY)** into the slots in two adjacent Wall/Shelf Support Channels. **The Shelf Brackets must be at the same height.** Attach a **Shelf (AFS)** to the Brackets using four (4) **Screws (ADZ)**.
- Insérer deux (2) **équerres (AIY)** dans les fentes dans deux canaux de support pour les murs/étagères adjacents. **Les équerres doivent être à la même hauteur.** Attacher une **étagère (AFS)** aux équerres à l'aide de quatre (4) **vis (ADZ)**.
- Insertar dos (2) **escuadras (AIY)** en las ranuras en dos canales de soporte para las paredes/estantes adyacentes. **Las escuadras deben estar a la misma altura.** Sujetar un **estante (AFS)** a las escuadras usando cuatro (4) **tornillos (ADZ)**.

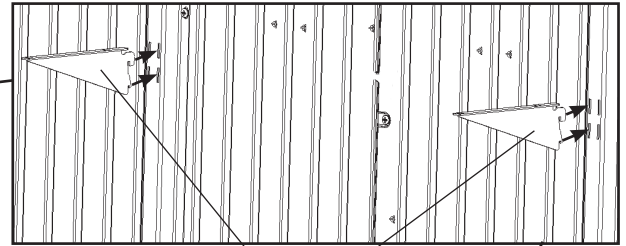
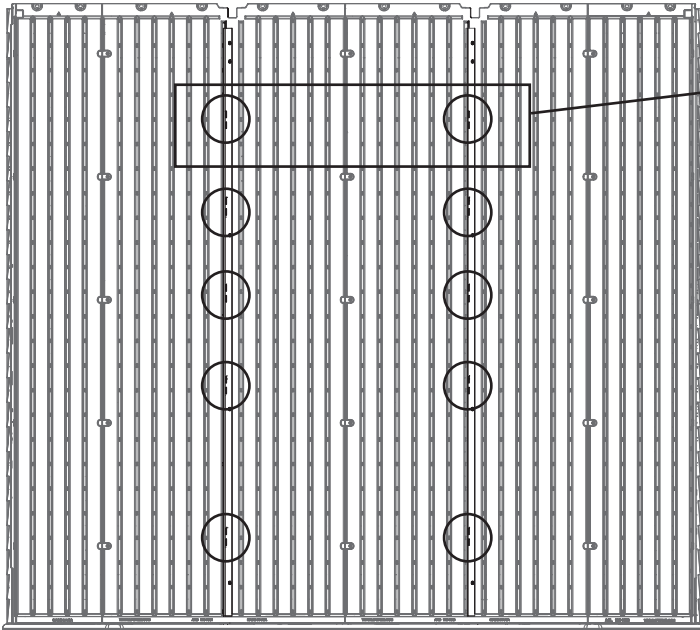

1

AIY

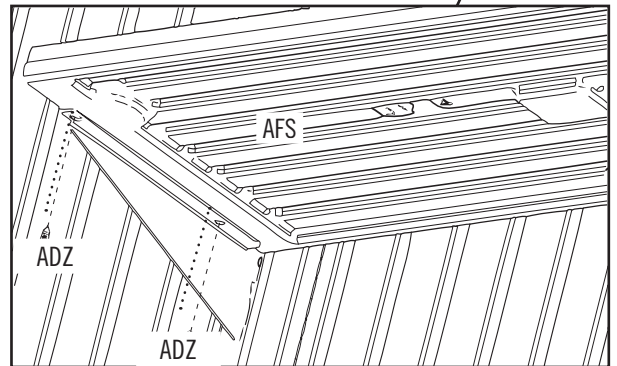

2

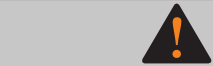

↓ 30 lb. (14 kg)

► SECTION 14 (CONTINUED) / SECTION 14 (SUITE) / SECCIÓN 14 (CONTINUACIÓN)

TOOLS AND HARDWARE REQUIRED / OUTILS ET QUINCAILLERIE REQUIS / INSTRUMENTAL Y HERRAJE REQUERIDOS

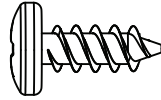

ADZ (x8)

14.2

- Fold up the flaps of a **Corner Shelf (AFZ)** and place it in any corner of the Shed. Align the holes in the flaps with those in the Corner Wall Panel. Secure with four (4) **Screws (ADZ)**.
- Plier les bords de l'**étagère angulaire (AFZ)** et mettez-le dans any corner de l'abri. Aligner les trous dans les bords avec ceux dans le panneau angulaire. Attacher-le au mur à l'aide de quatre (4) **vis (ADZ)**.
- Doblar los bordes del **estante angular (AFZ)** y colocarlo en cualquier esquina de la caseta. Alinear los agujeros en los bordes con los agujeros en el panel angular. Sujetar el estante usando cuatro (4) **tornillos (ADZ)**.

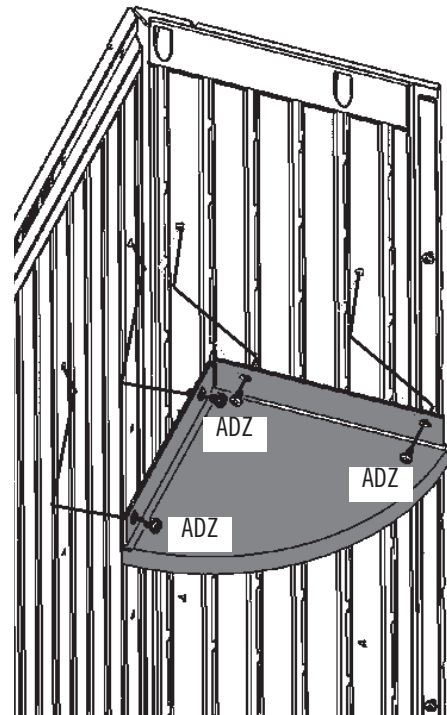
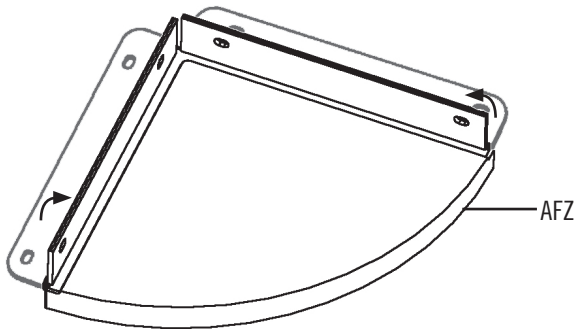

↓ **10 lb. (4.5 kg)**

14.3

- Repeat the previous step for the second Corner Shelf.
- Répéter l'étape précédente pour la deuxième étagère angulaire.
- Repetir paso anterior para el segundo estante angular.



CLEANING & CARE

Congratulations on your Lifetime® product purchase. By following the instructions below, your new Lifetime product should provide you with years of service and enjoyment.

The polyethylene panels are stain and solvent resistant. Most stains can be removed using a mild soap and a soft-bristled brush. Abrasive cleaning materials may scratch the plastic and are not recommended. Repair scratches or rust spots on the metal by sanding the affected area lightly; using a rust preventative spray primer; and finally, spraying with a high-gloss spray enamel paint. Avoid placing a direct heat source on or near surfaces unless using a heat barrier.



NETTOYAGE ET ENTRETIEN

Nous vous félicitons d'avoir acheté ce produit Lifetime®. En suivant les instructions ci-dessous, votre nouveau produit Lifetime devrait vous fournir des années de service et de plaisir.

Les murs et les étagères en polyéthylène sont résistants aux taches et solvants de nettoyage. Pour les nettoyer, servez-vous d'un savon doux et d'une brosse douce. Les produits abrasifs de nettoyage risquent d'égratigner le plastique et ne sont pas recommandés. Pour réparer les égratignures ou taches de rouille sur le métal, frottez légèrement l'endroit affecté au papier de verre, puis passez un couche de produit vaporisant préventif et enfin vaporisez une peinture émail ultrabrillante. Évitez de placer une source de chaleur directe sur ou près des surfaces, ou protégez-les à l'aide d'une protection contre la chaleur.



LIMPIEZA Y CUIDADO

Felicidades por la compra de su producto Lifetime®. Al seguir las siguientes instrucciones, su nuevo producto Lifetime le brindará años de servicio y satisfacción.

Los paneles de polietileno son resistentes a las manchas y solventes. La mayoría de las manchas puede removerse usando un jabón suave y un cepillo de cerdas suaves. Los materiales abrasivos para limpieza pueden rayar el plástico y no se recomiendan. Repare rayones o manchas de óxido en el metal, lijando suavemente la parte afectada; usando un aerosol preventivo de óxido y finalmente, rociando con una pintura de esmalte brillante. Evite poner una fuente de calor directa en o cerca de las superficies a menos que utilice una barrera de calor.



REGISTER YOUR PRODUCT ONLINE AT WWW.LIFETIME.COM

At Lifetime®, we are committed to providing innovative and quality products. While registering, you will have the opportunity to give us your feedback. Your input is valuable to us.

- You can also opt in to receive new product notifications or promotions.
- In the unlikely event of a product recall or safety modification, your registration provides the information we need to notify you directly.
- Registration is fast, easy, and completely voluntary.

LIFETIME'S PROMISE TO YOU:

Maintaining your privacy is our long-standing policy at Lifetime®. And you can rest assured that Lifetime® will not sell or provide your personal data to other third parties, or allow them to use your personal data for their own purposes.

We invite you to read our privacy policy at www.lifetime.com

REGISTER today!



ENREGISTRER CE PRODUIT EN LIGNE À WWW.LIFETIME.COM

Chez Lifetime®, nous nous engageons à fournir des produits innovateurs de qualité. Lors de votre inscription, vous aurez l'occasion de nous faire parvenir vos commentaires. Votre opinion est importante pour nous.

- On peut également choisir de recevoir des avis ou des promotions dans le cadre de nouveaux produits.
- Dans l'éventualité improbable d'un rappel ou d'un avis de sécurité, l'inscription fournit les renseignements nécessaires nous permettant de communiquer avec vous.
- L'inscription est rapide, facile et complètement volontaire.

LA PROMESSE DE LIFETIME :

Conserver votre confidentialité est notre politique de longue date chez Lifetime®. Vous pouvez donc être rassuré par le fait que Lifetime® ne vendra pas ou ne fournira pas vos données personnelles à des tiers, et ne leur permettra pas d'utiliser vos données personnelles à leurs propres fins.

Nous vous invitons à lire notre politique de confidentialité à www.lifetime.com

ENREGISTRER CE PRODUIT aujourd'hui!



REGISTRAR EL PRODUCTO EN LÍNEA EN WWW.LIFETIME.COM

En Lifetime®, estamos comprometidos a ofrecer productos innovadores y de calidad. Al registrarse, usted tendrá la oportunidad de darnos su retroalimentación. Su información es valiosa para nosotros.

- También puede optar por recibir nuestras notificaciones o promociones.
- En el caso improbable de que el producto tenga que salir del mercado o que sufra alguna modificación, su registro provee la información que necesitamos para notificarle directamente.
- El registro es rápido, fácil y completamente voluntario.

LA PROMESA DE LIFETIME® PARA USTED:

Mantener privacidad es nuestra política permanente en Lifetime®. Y puede estar seguro que Lifetime® no venderá ni dará datos personales a terceros, ni les permitirá usar datos personales para fines propios.

Lo invitamos a leer nuestra política de privacidad en www.lifetime.com

¡REGISTRARSE hoy mismo!



10-YEAR LIMITED FACTORY WARRANTY

THE MANUFACTURER RESERVES THE RIGHT TO MAKE SUBSTITUTIONS TO WARRANTY CLAIMS IF PARTS ARE UNAVAILABLE OR OBSOLETE.

1. Lifetime outdoor sheds are warranted to the original purchaser to be free from defects in material or workmanship for a period of ten years from the date of original retail purchase. The word “defects” is defined as imperfections that impair the use of the product. Defects resulting from misuse, abuse or negligence will void this warranty. This warranty does not cover defects due to improper installation, alteration or accident. This warranty does not cover damage caused by vandalism, rusting, “acts of nature” or any other event beyond the control of the manufacturer.
2. This warranty is nontransferable and is expressly limited to the repair or replacement of defective product. If the product is defective within the terms of this warranty, Lifetime Products, Inc. will repair or replace defective parts at no cost to the purchaser. Shipping charges to and from the factory or distribution center are not covered and are the responsibility of the purchaser. Labor charges and related expenses for removal, installation or replacement of the shed or its components are not covered under this warranty.
3. This warranty does not cover scratching or scuffing of the product that may result from normal usage. In addition, defects resulting from intentional damage, negligence, unreasonable use or hanging from the truss will void this warranty.
4. Liability for incidental or consequential damages is excluded to the extent permitted by law. While every attempt is made to embody the highest degree of safety in all equipment, freedom from injury cannot be guaranteed. The user assumes all risk of injury resulting from the use of this product. All merchandise is sold on this condition, and no representative of the company may waive or change this policy.
5. This product is not intended for institutional or commercial use; Lifetime Products, Inc. does not assume any liability for such use. Institutional or commercial use will void the warranty.
6. Our goods come with guarantees that cannot be excluded under the Australian Consumer Law. You are entitled to a replacement or refund for a major failure and for compensation for any other reasonably foreseeable loss or damage. You are also entitled to have the goods repaired or replaced if the goods fail to be of acceptable quality and the failure does not amount to a major failure.
7. This warranty is expressly in lieu of all other warranties, expressed or implied, including warranties of merchantability or fitness for use to extent permitted by Federal and state law. Neither Lifetime Products, Inc., nor any representative assumes any other liability in connection with this product. This warranty gives you specific legal rights, and you may also have other rights which vary from state to state (or province to province, as applicable in Canada).

PLEASE INCLUDE YOUR DATED SALES RECEIPT AND PHOTOGRAPHS OF DAMAGED PARTS.

REPORT PRODUCT DEFECTS IN WRITING TO:

Lifetime Products, Inc., PO Box 160010 Clearfield, UT 84016-0010
or call 1-800-225-3865 M-F 7 a.m. to 5 p.m. MST.

REGISTER YOUR PRODUCT FOR QUICKER CUSTOMER SERVICE.

Visit www.lifetime.com or call 1-800-225-3865 to register your product today.

FOR INTERNATIONAL WARRANTY CLAIMS:

All warranty claims must be accompanied by a sales receipt. Report all warranty claims in writing to your regional sales support representative. Please include your dated sales receipt and photographs of damaged parts.

To identify the representative for your region, please visit: www.lifetime.com/international



www.lifetime.com



GARANTIE DE FABRICATION LIMITÉE DE 10 ANS

LE FABRICANT RÉSERVE LE DROIT DE FAIRE DES SUBSTITUTIONS EN CAS DE RECOURS EN GARANTIE SI LES PIÈCES NE SONT PAS DISPONIBLES OU SONT OBSOÈTES

1. Les abris extérieurs Lifetime® sont garantis à l'acheteur d'origine contre tous défauts de matériau ou de fabrication pendant une durée de dix ans à partir de la date d'achat d'origine. Le mot « défauts » signifie des défauts qui empêchent l'utilisation du produit. Les défauts résultant de mauvais usage, d'abus ou de négligence annulent cette garantie. Cette garantie ne couvre pas les dommages causés par le vandalisme, la rouille, « les calamités naturelles » ou tout autre événement en dehors du contrôle du fabricant.
2. Cette garantie n'est pas transférable et est expressément limitée à la réparation ou au remplacement du produit défectueux. Si le produit est déclaré défectueux selon les termes de cette garantie, Lifetime® Products, Inc. réparera ou remplacera les parties défectueuses gratuitement pour l'acheteur. Les frais d'expéditions aller et retour de l'usine ne sont pas couverts et sont à la charge de l'acheteur. Les frais de main-d'œuvre et frais associés à l'enlèvement, au montage ou au remplacement de l'abri ou de ses composantes ne sont pas couverts par cette garantie.
3. Cette garantie ne couvre pas les égratignures ou éraillures du produit résultant d'une utilisation normale. Par ailleurs, les défauts résultant de dommages intentionnels, négligence, utilisation abusive ou suspension à partir de l'entretoise annulent cette garantie.
4. Toute responsabilité pour dommages incidents ou consécutifs est exclue dans la mesure permise par la loi. Bien que toutes les mesures aient été prises pour intégrer le plus haut degré de sécurité dans l'ensemble du matériel, l'impossibilité de blessure ne peut pas être garantie. L'utilisateur assume tous les risques de blessure résultant de l'utilisation de ce produit. L'ensemble de la marchandise est vendu en vertu de cette condition et aucune personne représentant la société ne peut déroger à cette politique, ni la modifier.
5. Ce produit n'est pas prévu pour l'usage institutionnel ni commercial; Lifetime® Products, Inc. n'assume aucune responsabilité pour tel usage. L'utilisation institutionnelle ou commerciale annulera cette garantie.
6. Nos articles sont offerts avec des garanties qui ne peuvent connaître d'exclusions au regard de la loi australienne sur la protection des consommateurs. Vous avez droit au remplacement ou au remboursement en cas de défaillance majeure de votre article ainsi qu'à une compensation en cas de perte ou de dommage prévisible. Vous avez aussi droit à la réparation ou au remplacement de l'article s'il n'est pas d'une qualité acceptable et que la défaillance n'est pas majeure.
7. Cette garantie remplace expressément toutes autres garanties, expresses ou tacites, y compris les garanties de commercialisation ou d'adaptation à un but particulier dans la mesure permise par les lois fédérales et des états. Ni Lifetime® Products, Inc. ni aucun de ses représentants n'assume aucune autre responsabilité concernant ce produit. Cette garantie vous accorde des droits particuliers, et vous aurez peut-être d'autres droits qui varient d'un état à l'autre (ou d'une province à l'autre, selon le cas au Canada).

TOUS LES RECOURS EN GARANTIE DOIVENT ÊTRE ACCOMPAGNÉS DU REÇU DE VENTE.

FAIRE PARVENIR UN RAPPORT PAR ÉCRIT DE DÉFECTUOSITÉ DU PRODUIT A :

Lifetime Products, Inc., PO Box 160010 Clearfield, UT 84016-0010
ou composer 1.800.225.3865 lundi à vendredi 0700 - 1700 (HNR)

ENREGISTRER VOTRE ARTICLE À :

www.lifetime.com, ou composer 1.800.225.3865 pour enregistrer votre article aujourd'hui.

POUR RECOURS EN GARANTIE INTERNATIONAUX:

Tous les recours en garantie doivent être accompagnés du reçu de vente. Faire parvenir un rapport par écrit de défectuosité du produit au représentant régional de ventes. Veiller à inclure votre reçu de vente daté et photographies des pièces endommagées. Pour identifier le représentant régional, visiter www.lifetime.com/international



www.lifetime.com



GARANTÍA DE FÁBRICA LIMITADA POR 10 AÑOS

EL FABRICANTE SE RESERVA EL DERECHO DE HACER SUSTITUCIONES EN LOS ELEMENTOS REEMPLAZADOS BAJO GARANTÍA SI LAS PIEZAS NO ESTÁN DISPONIBLES O SON OBSOLETAS.

1. El comprador original recibe la garantía de que las casetas Lifetime estarán libres de defectos de material o de mano de obra por un período de 10 años a contar desde la fecha de la compra original. La palabra “defectos” se define como imperfecciones que perjudican el uso del producto. Los defectos emergentes de un mal uso, abuso o negligencia invalidarán esta garantía. Esta garantía no cubre defectos debidos a una instalación o alteración incorrecta o a un accidente. Esta garantía no cubre daños causados por vandalismo, oxidación, “actos de la naturaleza” u otros eventos que estén más allá del control del fabricante.
2. Esta garantía es intransferible, y queda expresamente limitada a la reparación o reemplazo de los productos defectuosos. Si el producto se encuentra defectuoso dentro de los términos de esta garantía, Lifetime Products, Inc. reparará o reemplazará las piezas defectuosas sin costo alguno para el comprador. Los gastos de envío hacia y desde la fábrica no están cubiertos, y quedan bajo la responsabilidad del comprador.
3. Esta garantía no cubre raspaduras ni marcas en el producto que pueden resultar de su uso normal. Además, los defectos causados por daños intencionales, negligencia, uso irrazonable o por colgarse de las cabriadas invalidarán esta garantía.
4. La responsabilidad por daños incidentales o consecuentes queda excluida hasta el punto en que lo permita la ley. Si bien se hace el mayor esfuerzo posible para lograr el más alto grado de seguridad en todos nuestros equipos, no puede garantizarse la libertad de cualquier tipo de lesión. El usuario asume todos los riesgos de lesiones emergentes del uso de este producto. Toda nuestra mercadería se vende bajo esta condición, y ningún representante de la compañía puede anular ni cambiar esta política.
5. Este producto no está pensado para el uso institucional ni comercial; Lifetime Products, Inc. no asume ninguna otra responsabilidad en conexión con este producto. El uso institucional o comercial invalidará la garantía.
6. Nuestros productos vienen con garantías que no se pueden excluir bajo la Ley del consumidor de Australia. Ustedes están autorizados para reemplazarlos u otorgar una devolución o reembolso en caso de falla mayor y en compensación por cualquier otra falla o daño previsible. También, están autorizados para hacer reparar los productos o reemplazarlos si éstos no cumplen con una calidad aceptable y si la falla no es motivo de una deficiencia mayor.
7. Esta garantía se otorga en reemplazo expreso de toda otra garantía, expresa o implícita, incluidas las garantías de comercialización o adaptación para el uso en la medida permitida por las leyes federales y estatales. Ni Lifetime Products, Inc., ni ninguno de sus representantes asume ninguna otra responsabilidad en conexión con este producto. Esta garantía le otorga derechos legales específicos, y usted puede tener otros derechos que varían de estado a estado (o de una provincia a otra, según corresponda en Canadá).

NINGUNA GARANTÍA OFRECIDA POR EL FABRICANTE ES VÁLIDA EN MÉXICO

TODOS LOS RECLAMOS DE GARANTÍA DEBEN ESTAR ACOMPAÑADOS POR UN RECIBO DE COMPRA

INFORME POR ESCRITO LOS DEFECTOS EN EL PRODUCTO A:

Por favor, incluir el recibo de compra fechado y fotografías de las piezas dañadas.

Lifetime Products, Inc., PO Box 160010 Clearfield, UT 84016-0010,

o marcar al 1.800.225.3865 de lunes a viernes de 0700 hasta 1700 (Hora de las Montañas)

REGISTRAR SU PRODUCTO

Visitar nuestra página en Internet www.lifetime.com, o marcar al 1.800.225.3865 para registrar el producto hoy.

PARA RECLAMOS DE GARANTÍA INTERNACIONALES:

Todos los reclamos de garantía deben estar acompañados por un recibo de compra. Informar por escrito todos los reclamos de garantía a su representante regional de ventas. Favor de incluir el recibo de compra fechado y fotografías de las piezas dañadas.

Para identificar el representante regional, visitar www.lifetime.com/international



www.lifetime.com



IMPORT INFORMATION / IMPORTATIONS / INFORMACIÓN DE IMPORTACIONES

Distributed by:

Costco Wholesale Corporation
P.O. Box 34535
Seattle, WA 98124-1535
USA
1-800-774-2678
www.costco.com

Importado por:

Importadora Primex S.A. de C.V.
Blvd. Magnocentro No.4
San Fernando La Herradura
Huixquilucan, Estado de México
C.P. 52765
RFC: IPR-930907-S70
(55)-5246-5500
www.costco.com.mx

Imported by:

Costco Wholesale UK Ltd /
Costco Online UK Ltd
Hartspring Lane
Watford, Herts
WD25 8JS
United Kingdom
01923 213113
www.costco.co.uk

Imported and Distributed by:

Costco Wholesale Korea, Ltd.
40, Iljik-ro
Gwangmyeong-si
Gyeonggi-do, 14347, Korea
1899-9900
www.costco.co.kr

Imported by:

Costco Wholesale Japan Ltd.
3-1-4 Ikegami-Shincho
Kawasaki-ku, Kawasaki-shi,
Kanagawa 210-0832 Japan
044-281-2600
www.costco.co.jp

Distributed by:

Costco Wholesale Iceland ehf.
Kauptún 3-7, 210 Gardabaer
Iceland
www.costco.is

Imported by / Importé par :

Costco Wholesale Canada Ltd.*
415 W. Hunt Club Road
Ottawa, Ontario
K2E 1C5, Canada
1-800-463-3783
www.costco.ca

* faisant affaire au Québec sous le nom Les Entrepôts Costco

Imported by:

Costco Wholesale Australia Pty Ltd
17-21 Parramatta Road
Lidcombe NSW 2141
Australia
www.costco.com.au

Importado por:

Costco Wholesale Spain S.L.U.
Polígono Empresarial Los Gavilanes
C/ Agustín de Betancourt,17
28906 Getafe (Madrid) España
NIF : B86509460
900 111 155
www.costco.es

Imported by / Manufactured for:

Costco President Taiwan, Inc.
No. 656 Chung-Hwa 5th Road
Kaohsiung, Taiwan
Company Tax ID: 96972798
449-9909 or 02-449-9909 (if cellphone)
www.costco.com.tw

Distribué par :

Costco France
1 avenue de Bréhat
91140 Villebon-sur-Yvette
France
01 80 45 01 10
www.costco.fr

Imported by / Distributed by:

Shanghai Minhang Costco Trading Co., Ltd
Unit 109, No 388, Lian You Road
Minhang District, Shanghai
China 201107
+86-21-6257-7065

Made in China
Fabriqué en Chine
Hecho en China



ENHANCE YOUR LIFETIME® PURCHASE BY ADDING ACCESSORIES OR OTHER GREAT PRODUCTS

To purchase accessories or other Lifetime® products, visit us at:

www.lifetime.com

Or call: 1-800-424-3865

7:00 am–5:00 pm (M–F) MST and 9:00 am–1:00 pm Saturday MST

AMÉLIORER L'ACHAT LIFETIME® EN AJOUTANT DES ACCESSOIRES OU D'AUTRES PRODUITS

Pour acheter des accessoires ou des autres produits Lifetime®, visiter le :

www.lifetime.com

Ou composer le 1-800-424-3865

Du lundi au vendredi de 7 h à 17 h, HR et le samedi de 9 h à 13 h, HR

MEJORAR LA COMPRA DE LIFETIME® AGREGANDO ACCESORIOS U OTROS MARAVILLOSOS PRODUCTOS

Para comprar accesorios u otros productos de Lifetime®, visitarnos en:

www.lifetime.com

O marcar al: 1-800-424-3865

De lunes hasta viernes 7:00 h–17:00 h Horario Estándar de la Montaña (MST) y sábados 9:00 h–13:00 h (MST)



www.lifetime.com

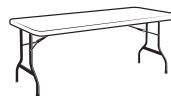

Made in China / Fabriqué en Chine / Hecho en China