

Shark

Shark® Cordless Vacuum

BU3500 series

OWNER'S GUIDE



THANK YOU

for purchasing the Shark® Cordless Vacuum.



TIP: You can find the model and serial numbers on the QR code label located on the back of your unit.

TIP: You can locate the date code on one of the prongs of the power cord plug.

REGISTER YOUR PURCHASE

TO BENEFIT FROM YOUR PRODUCT'S EXTENDED GUARANTEE, SIMPLY REGISTER YOUR PURCHASE AT:

 sharkclean.co.uk/register-guarantee

 +44 (0)800 862 0453

 Scan QR code using mobile device

Please note, products purchased directly from Shark® are automatically registered.

Benefits of registering your product and creating an account:

- Get easier, faster product support and access to guarantee information
- Access troubleshooting and product care instructions
- Be among the first to know about exclusive product promotions

RECORD THIS INFORMATION

Model Number: _____

Serial Number: _____

Date Code: _____

Date of Purchase (Keep Receipt): _____

Store of Purchase: _____

TECHNICAL SPECIFICATIONS

Voltage: 21.6V

Body Motor Watts: 240W

Nozzle Watts: 60W

PLEASE READ CAREFULLY AND KEEP FOR FUTURE REFERENCE.

This instruction manual is designed to help you get a complete understanding of your new Shark® Cordless Vacuum.

If you have any questions, please call the customer service line on +44 (0)800 862 0453.

CONTENTS

Product Registration	2
Important Safety Instructions	4
Assembling your Shark® Vacuum Cleaner	6
LI-ION Battery	7
Using Your Vacuum	8
Controls And Cleaning Modes	8
Using The Auto Empty Dock (BU3500 Series Only)	9
Quiet Mode	9
Battery removal	9
Charging your Li-ion Battery	10
Maintaining your Vacuum Cleaner	11
Emptying The Dock Dust Bin (BU3500 Series Only)	11
Emptying the Handheld Vacuum Dust Cup	11
Cleaning The Dust Cup And Filter	12
Cleaning The Auto Empty Dock Filter (BU3500 Series Only)	13
Nozzle Maintenance	13
Checking For Blockages In The Vacuum	14
Checking For Blockages In The Auto Empty Dock (BU3500 Series Only) ..	14
Troubleshooting	15
Additional Accessories Available	16
Guarantee	17



This marking indicates that this product should not be disposed with other household wastes. To prevent possible harm to the environment or human health from uncontrolled waste disposal, recycle it responsibly to promote the sustainable reuse of material sources. To return your used device, please use the return and collection systems or contact the retailer where this product was purchased. They can take this product for environmentally safe recycling.



IMPORTANT SAFETY INSTRUCTIONS

FOR HOUSEHOLD USE ONLY • PLEASE READ ALL INSTRUCTIONS BEFORE USING THIS VACUUM.

To reduce the risk of shock and unintended operation, turn off power and remove the ION Power Pack battery before servicing.

NOTE: If you have delicate or wool carpets, particularly loop pile, please try the vacuum on a hidden area first to ensure the spinning brush-rolls do not damage or unpick carpet fibres.



⚠ WARNING

REDUCE THE RISK OF FIRE, ELECTRIC SHOCK, INJURY, OR PROPERTY DAMAGE:

1. This vacuum consists of a motorised nozzle, wand, and handheld vacuum. These components contain electrical connections, electrical wiring, and moving parts that potentially present risk to the user.
 2. Before each use, carefully inspect all parts for any damage. If a part is damaged, discontinue use.
 3. Use only identical replacement parts.
 4. This vacuum contains no serviceable parts.
 5. Use only as described in this manual. **DO NOT** use the vacuum for any purpose other than those described in this manual.
 6. With the exception of the filters and dust cup, **DO NOT** expose any parts of the vacuum to water or other liquids.
 7. **DO NOT** allow the appliance to be used by children. Keep the appliance and its cord out of reach of children. Do not allow to be used as a toy. Close supervision is necessary when used near children.
- ### GENERAL USE
8. This appliance can be used by persons with reduced physical, sensory or mental capabilities or lack of experience and knowledge if they have been given supervision or instruction concerning use of the appliance in a safe way and understand the hazards involved. Cleaning and user maintenance should not be done by children.
 9. Always turn off the vacuum before connecting or disconnecting any current carrying hoses, motorised nozzles, chargers, batteries, or other electrical or mechanical parts.
 10. **DO NOT** handle plug or vacuum with wet hands.
 11. **DO NOT** use without dust cup, filters, and brush-roll in place.
 12. Only use Shark® branded filters and accessories. Damage caused by non-Shark® filters and accessories may not be covered by the guarantee.
 13. **DO NOT** put any objects into nozzle or accessory openings. **DO NOT** use with any opening blocked; keep free of dust, lint, hair, and anything that may reduce airflow.
 14. **DO NOT** use if nozzle or accessory airflow is restricted. If the air paths or the motorised floor nozzle become blocked, turn the vacuum off. Remove all obstructions before you turn on the unit again.
 15. Keep nozzle and all vacuum openings away from hair, face, fingers, uncovered feet, or loose clothing.
 16. **DO NOT** use if vacuum is not working as it should, or has been dropped, damaged, left outdoors, or dropped into water.
 17. Use extra care when cleaning on stairs.
 18. **DO NOT** leave the vacuum unattended while powered on.
 19. When powered on, keep the vacuum moving over the carpet surface at all times to avoid damaging the carpet fibres.
 20. If you have delicate or wool carpets, particularly loop pile, please try the vacuum on a hidden area first to ensure the spinning brush-rolls do not damage or unpick carpet fibres.
 21. **DO NOT** use to pick up:
 - a) Liquids
 - b) Large objects
 - c) Hard or sharp objects (glass, nails, screws, or coins)
 - d) Large quantities of dust (including drywall, fireplace ash, or embers). **DO NOT** use as an attachment to power tools for dust collection.
 - e) Smoking or burning objects (hot coals, cigarette butts, or matches)
 - f) Flammable or combustible materials (lighter fluid, petrol, or kerosene)
 - g) Toxic materials (chlorine bleach, ammonia, or drain cleaner)

22. **DO NOT** use in the following areas:
 - a) Poorly lit areas
 - b) Wet or damp surfaces
 - c) Outdoor areas
 - d) Spaces that are enclosed and may contain explosive or toxic fumes or vapours (lighter fluid, petrol, kerosene, paint, paint thinners, mothproofing substances, or flammable dust)
 23. Turn off the vacuum before plugging in or unplugging the charger.
 24. Turn off the vacuum before any adjustment, cleaning, maintenance or troubleshooting.
 25. During cleaning or routine maintenance, **DO NOT** cut anything other than hair, fibres, or string wrapped around the brush-roll.
 26. Allow all filters to air-dry completely before replacing in the vacuum to prevent liquid from being drawn into electric parts.
 27. **DO NOT** modify or attempt to repair the vacuum or the battery yourself, except as indicated in this manual. **DO NOT** use the battery or vacuum if it has been modified or damaged. Damaged or modified batteries may exhibit unpredictable behavior resulting in fire, explosion or risk of injury.
 28. Turn off all controls before unplugging.
 29. Always turn off this appliance before connecting or disconnecting motorised nozzle or hand tool.
- ### BATTERY PACK
30. The battery is the power source for the vacuum. Carefully read and follow all charging instructions.
 31. To prevent unintentional starting, ensure the vacuum is powered off before picking up or carrying the vacuum. **DO NOT** carry the appliance with your finger on the power switch.
 32. For BU3500 Series, use only the XDCKBU3500SUK charging dock, DK25A-263080H-B or YLS0251A-U263080 chargers. Use of incorrect charger may result in no charging and/or unsafe conditions. If the power supply cord is damaged, it must be replaced by the manufacturer or approved service agent.
 33. Keep the battery away from all metal objects such as paper clips, coins, keys, nails, or screws. Shorting the battery terminals increases the risk of fire or burns.
 34. Under abusive conditions, liquid may be ejected from the battery. Avoid contact with this liquid, as it may cause irritation or burns. If contact occurs, flush with water. If liquid contacts eyes, seek medical help.
 35. Battery should not be stored at temperatures below 3°C (37.4°F) or above 40°C (104°F) to maintain long-term battery life.
 36. **DO NOT** charge battery at temperatures below 5°C (40°F) or above 40°C (104°F). Charging improperly or at temperatures outside of the specified range may damage the battery and increase the risk of fire.
 37. Store the appliance indoors.
 38. **DO NOT** expose the battery to fire or temperatures above 130°C (265°F) as it may explode.
 39. Use appliances only with specifically designated battery packs. Use of any other battery packs may create a risk of injury and fire.
 40. Disconnect the battery pack from the appliance before making any adjustments, changing accessories, or storing appliance. Such preventive safety measures reduce the risk of starting the appliance accidentally.
 41. For BU3500 Series use only Shark® battery pack XBTR625KSLEUN.

AUTO-EMPTY ASSEMBLY (BU3500 SERIES)

1. Slide the **Wand** onto the neck of the **Floor Nozzle** until it clicks into place.
2. Align the **Hand Vacuum** nozzle opening with the top of the wand and slide it on until it clicks into place.
3. Make sure the **Dock** is facing upright. Slide the **Charging Post** into the slot on front of dock until it clicks.
4. Place the dock on the floor near a wall outlet. Plug the **Power Cord** into the outlet, then connect the cord to the port on the back of the charging post.
5. Store the crevice tool accessory on the mount on the dock.

For proper operation, ensure all components are completely connected and clicked into place.

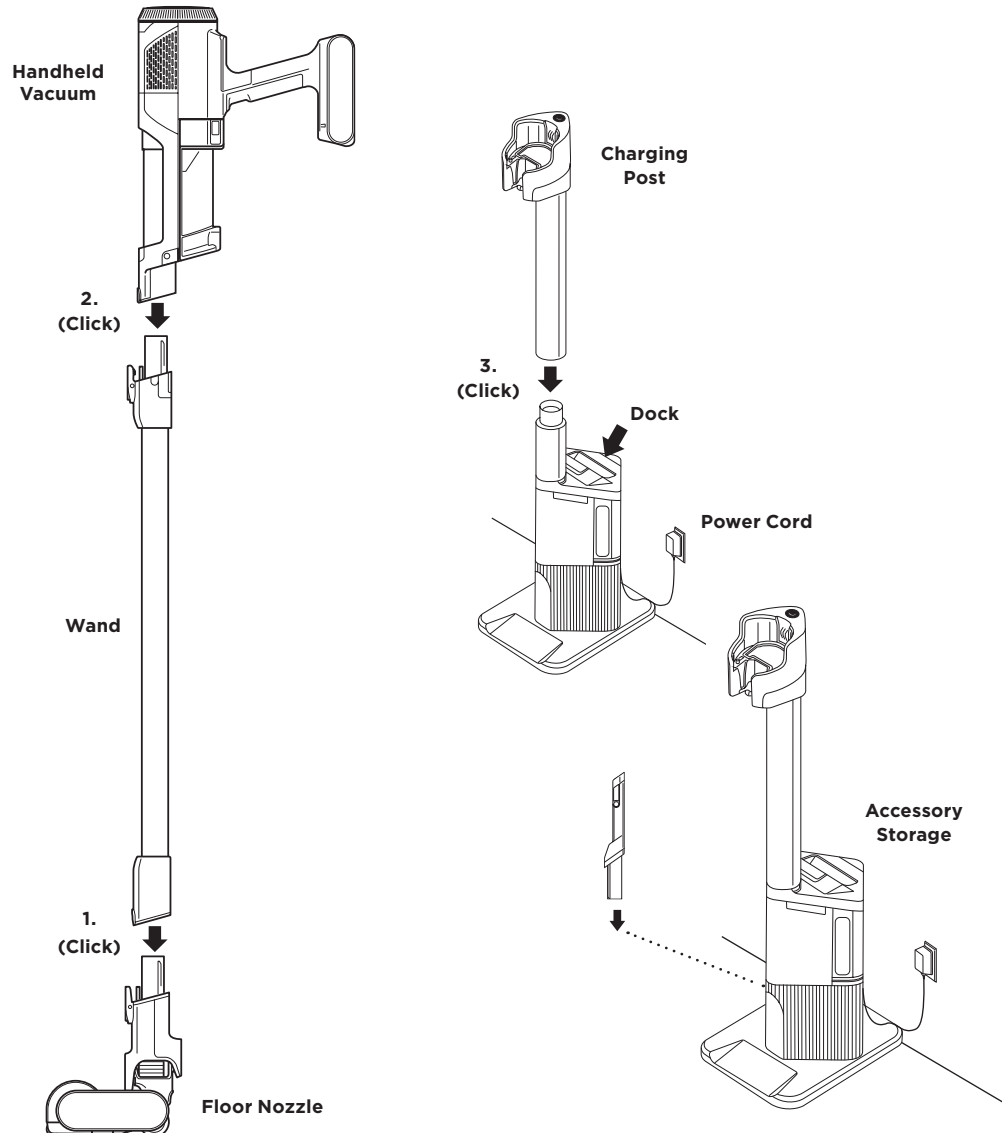

LI-ION BATTERY

Prior to first use, charge the battery completely. A full charge takes approximately 5 hours.

RUNTIMES PER FULLY CHARGED BATTERY

With a full charge, the unit will have up to a 40-minute runtime. Visit sharkclean.co.uk/support online for more information.

LED BATTERY POWER AND CHARGING INDICATORS

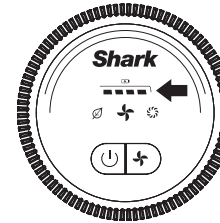

	Full Charge
	Mid Charge
	Low Charge
	Nearly Empty
	No Charge

Charging

LED on the battery pack will pulse yellow when reaching 0-74% charge.

LED on the battery pack will pulse green from 75% - 100% charge.

White LED the battery pack is fully charged.

NOTE: Full charge takes approximately 4.5 hours.

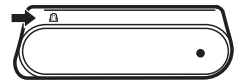

RECYCLING THE LI-ION BATTERY



When the Shark® Li-ion battery needs to be replaced, dispose of it or recycle it in accordance with local ordinances or regulations. In some areas, it is illegal to place spent lithium-ion batteries in the standard rubbish bin. Return spent batteries to an authorised recycling centre or to the retailer for recycling. Contact your local recycling centre for information on where to drop off the spent battery.

NOTE: The Shark® battery, like all lithium-ion batteries, will naturally decrease in capacity over time from the 100% capacity of a new battery.

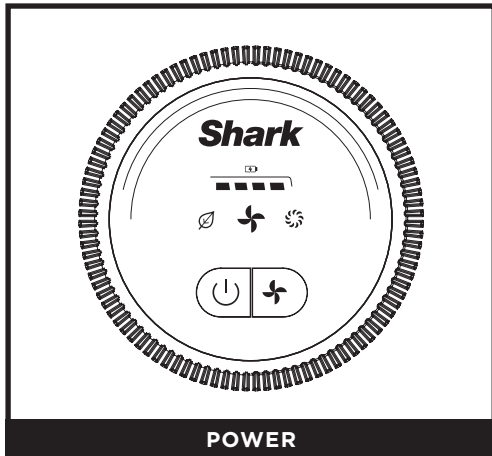
CONTROLS AND CLEANING MODES



POWER

Press the  button on the UI Screen to turn on power. To turn off power, press the button again. To toggle between ECO, AUTO and BOOST modes, press the mode  selection button.

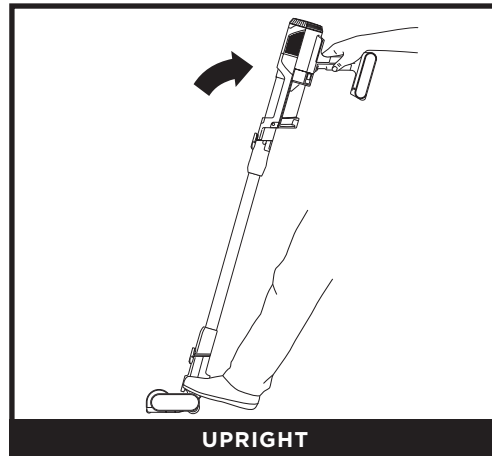

UPRIGHT

When upright, the nozzle will lock to allow for free standing storage when the hand vac is detached. Place your foot on the nozzle to disengage the lock to begin floor cleaning.

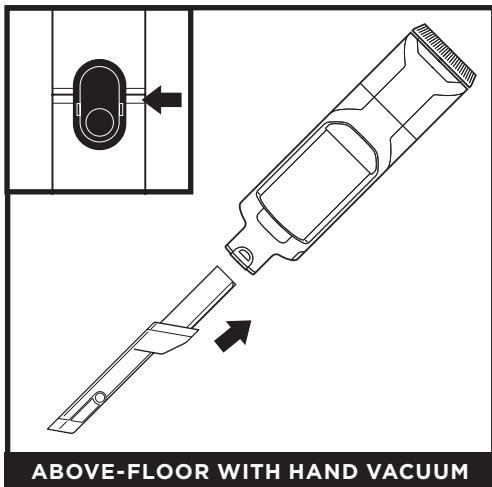

ABOVE-FLOOR WITH HAND VACUUM

Detach the hand vacuum to clean above-floor areas. Press the front latch release button on the hand vac where it meets the wand, then lift off the hand vacuum. To attach an accessory to the hand vacuum, slide it into the opening in the nozzle. To remove, press the front latch release button on the hand vac where it meets the wand, and slide out the accessory.

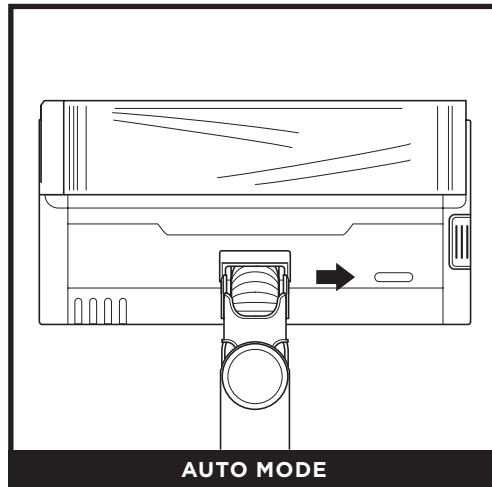

AUTO MODE

When the vacuum is in Auto mode, FloorDetect will automatically adjust the brushroll speed to optimize cleaning on different floor surfaces. The LED indicator on the nozzle will change color based on the floor type detected. When the nozzle detects a bare floor surface, the light will turn blue. When carpet is detected, the light will turn purple.

USING THE AUTO-EMPTY DOCK (BU3500 SERIES)

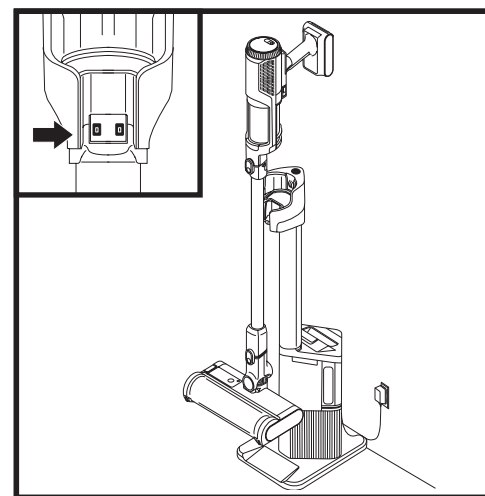

Place the vacuum on the dock in a downward motion. Once properly attached, the auto evacuation process will begin. The evacuation cycle will last for 10 seconds.

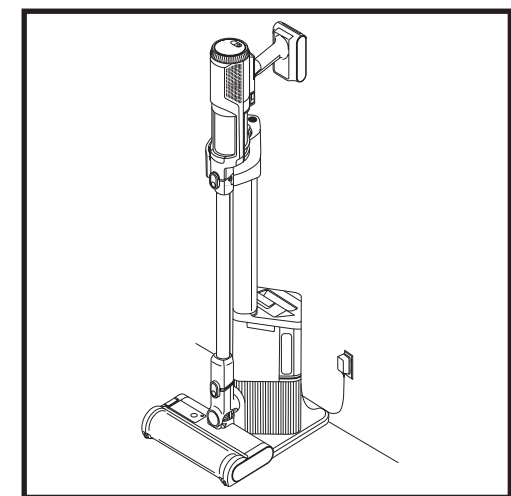

Once evacuation is complete, the vacuum will continue charging until it is removed from the dock.

QUIET MODE



QUIET MODE BUTTON LOCATION

Press the button on the top of the dock that shows an image of a moon. This will initiate Quiet Mode. When the dock is in Quiet Mode, you can dock the vacuum without auto evacuation occurring.

REMOVING THE BATTERY

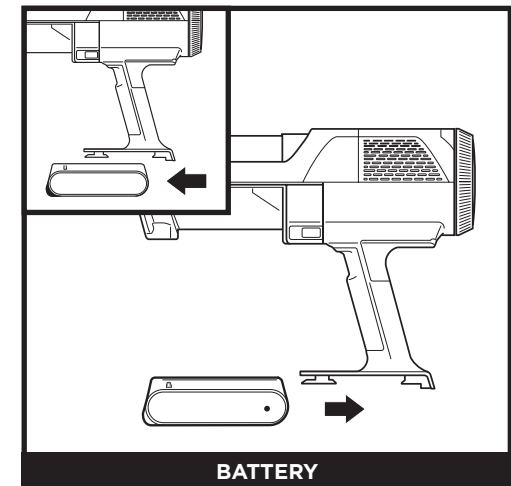

BATTERY

To remove the battery from the hand vacuum, press the release tab on the battery cap and slide out the battery. To reinstall, slide the battery into the compartment in the handle until it clicks into place.

CHARGING YOUR LI-ION BATTERY

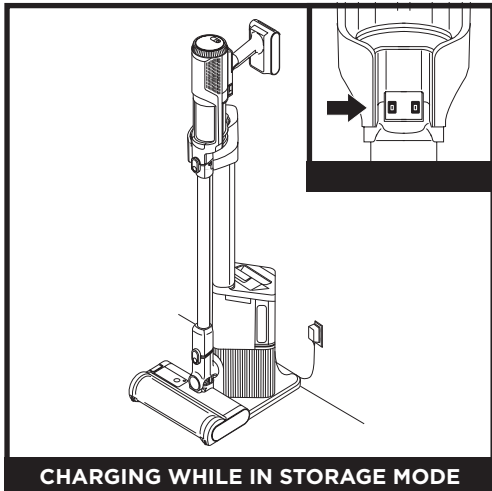

CHARGING WHILE IN STORAGE MODE

Charge the unit by placing it on the dock. Make sure the contacts on the wand are aligned with the contacts on the charging post. When charging is complete and you need to use the unit again, lift it off the dock.

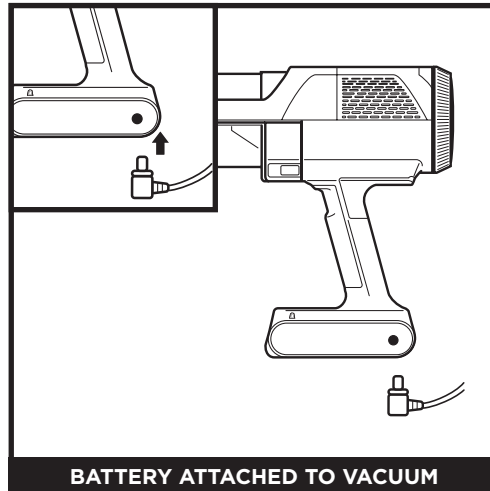

BATTERY ATTACHED TO VACUUM

To charge the battery whilst attached to the handheld vacuum, connect the charger to an electrical outlet, then insert the charger plug into the charging port on the battery.

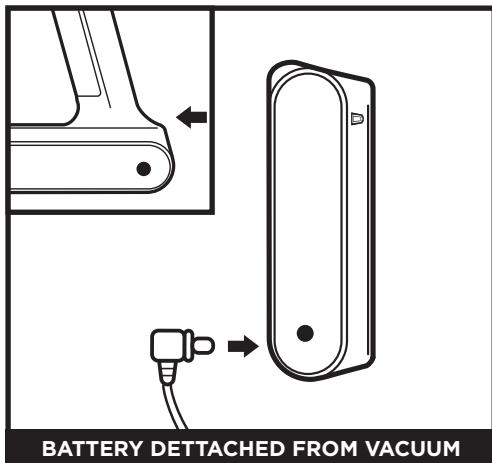

BATTERY DETTACHED FROM VACUUM

Press and hold the **Battery Release Button**, then pull out the battery. Plug the charger into the charging port on the battery. To reinstall the battery, insert it into the slot in the back of the handheld vacuum.

NOTE: When the unit is docked properly, the charging lights on the battery will blink, indicating that charging has begun.

NOTE: The main unit comes with a partial charge. For maximum runtime, charge fully before first use (approximately 5 hours). Leaving the unit plugged in will not damage battery life.

MAINTAINING YOUR VACUUM

EMPTYING THE DOCK DUST BIN (BU3500 SERIES)

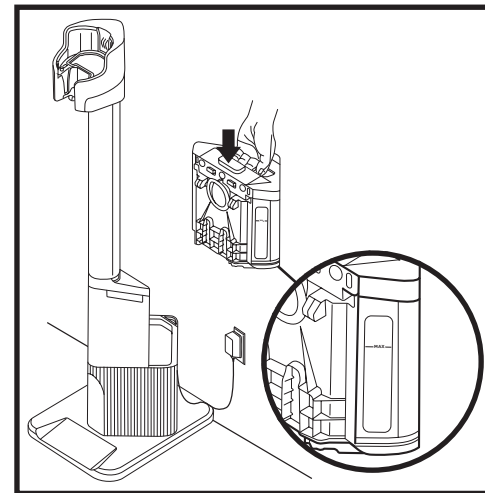

The dock dust bin holds up to 30 days' worth of dust and debris. Empty the dock dust bin when debris reaches "Max" fill line. To remove the bin, lift it out by the handle.

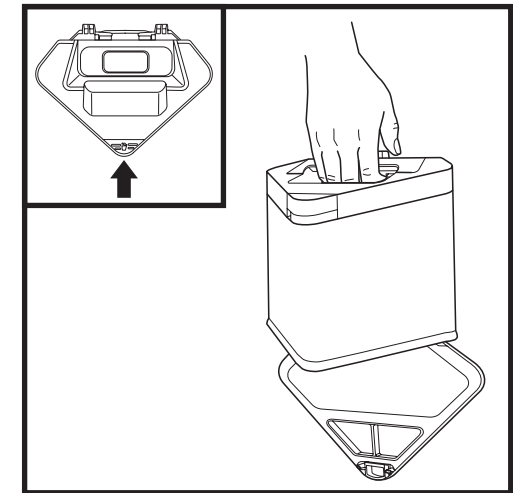

To empty the bin, hold it over the bin and press the release button on the side. The bottom will open to release the debris.

EMPTYING THE HANDHELD VACUUM DUST CUP

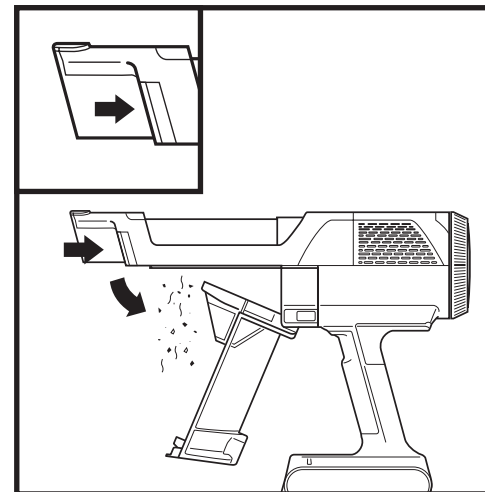

To empty the handheld vacuum dust cup, turn off the power and hold the hand vac over the bin. Press the release button and the dust cup lid will drop open, releasing debris.

CLEANING THE DUST CUP AND FILTER

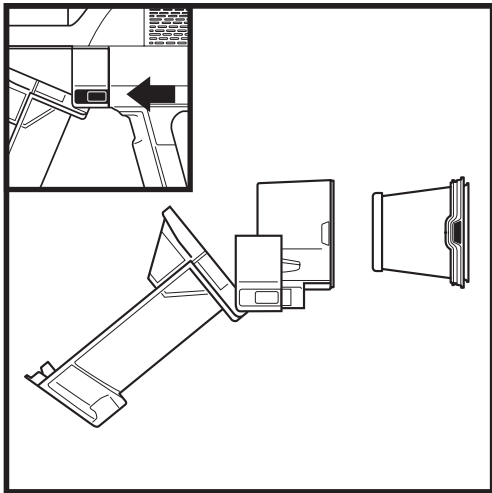

With the dust cup open and the power off, press both release buttons and slide the dust cup out of the hand vac. Press the tabs on both sides of the filter housing and pull the filter out of the housing. To clean the filter, rinse it with water only and allow it to air-dry for at least 24 hours before reinstalling. To reinstall the filter, slide it back into the housing, then slide the housing back into place.

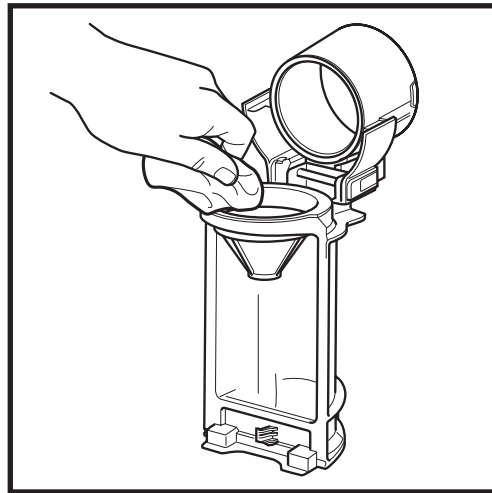

To deep-clean the dust cup, slide the release button until the lid opens completely. Wipe away any dust and debris with a dry cloth, then rinse it out with water. Use a damp cloth to remove any remaining debris. Allow the dust cup to air-dry completely for at least 24 hours before reinstalling it.

IMPORTANT: DO NOT use soap when cleaning the filters. Use water only. The vacuum will not have suction if the post-motor filter is not installed. Ensure that all filters are installed before using.

CLEANING THE AUTO-EMPTY DOCK FILTER (BU3500 SERIES)

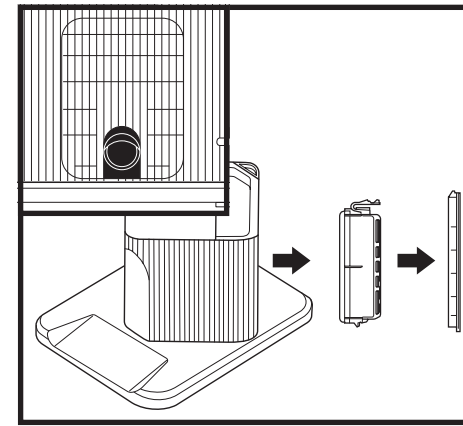

To access the filter in the dock, remove the Filter Door. Press the button at the bottom of the door, then tilt the door and lift it off. Remove the filter from the dock. After the filter has been rinsed and dried, reinstall it by reinserting it into the dock and replacing the filter door.

For best results, clean your Auto-Empty filters at least once a month and replace the filters regularly. To clean filters, rinse with cold water ONLY to prevent damage from cleaning chemicals. Allow all filters to air-dry for at least 24 hours before reinstalling them to prevent liquid from being drawn into electrical parts. Maintaining your Exhaust Foam Filter will ensure successful Auto-Empty evacuation.

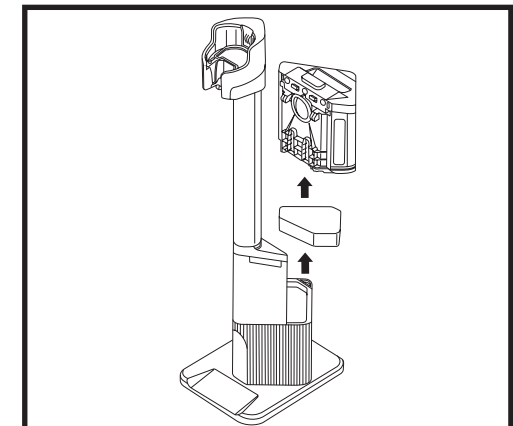

To access the the Auto-Empty Exhaust Foam Filter, remove the dust bin. Before removing the Exhaust Foam Filter, vacuum off any fine debris from the surface. Lift the Exhaust Foam Filter out of the dock, then rinse it with water only (do not use soap). Allow the filter to air-dry completely before reinstalling it.

NOZZLE MAINTENANCE

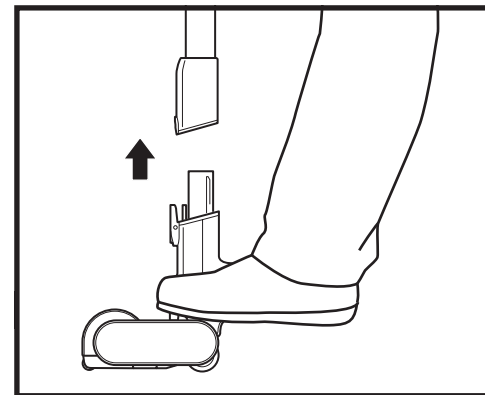

1. Turn off the vacuum.
2. Press the nozzle release button to detach the nozzle from the wand.
3. Press the brushroll release button and slide the brushroll out of the nozzle.
4. Clear any blockages and remove any debris from the brushroll and floor nozzle.

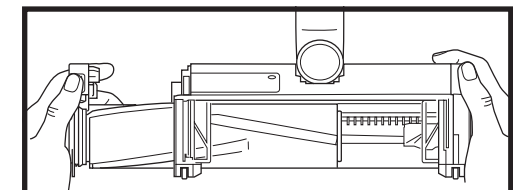
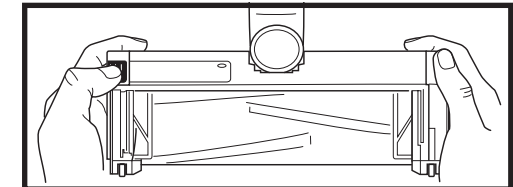

5. Tap off loose debris and wipe the brushroll clean with a dry towel. Hand wash the brushroll if needed, using only water, and then let it air dry completely for at least 24 hours.
6. When the brushroll is dry, reinstall it into the nozzle by inserting it into the nozzle until it clicks.

CHECKING FOR BLOCKAGES IN THE VACUUM

If you run over a hard or sharp object or notice a noise change while vacuuming, check for blockages or objects caught in the brushroll.

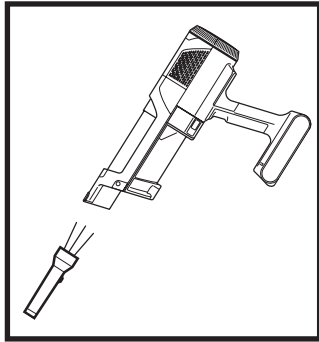

Checking for Blockages in the Hand Vacuum:

1. Turn off the vacuum.
2. Remove the hand vacuum from the wand.
3. Check all intake openings to the dust cup and remove any debris or blockages.

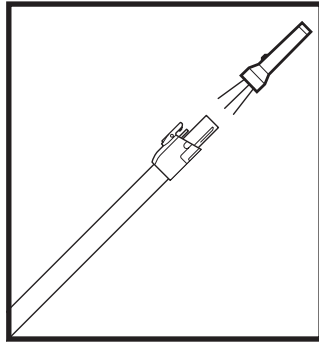

Checking for Blockages in the Wand:

1. Turn off the vacuum.
2. Detach the hand vacuum and floor nozzle from the wand.
3. Check both ends of the wand for blockages and debris.
4. Clear away any debris or blockages.

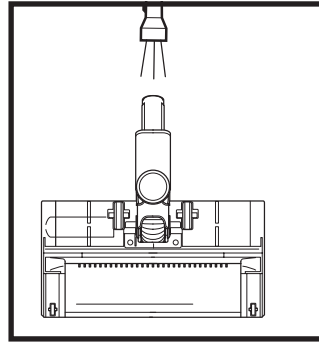

Checking for Blockages in the Floor Nozzle:

1. Turn off the vacuum.
2. Detach the wand from the floor nozzle.
3. Press the brushroll release button and slide the brushroll out of the nozzle.
4. Clear any blockages and release any debris from the brushroll and floor nozzle.
5. Slide the brushroll back into the nozzle, ensuring everything is lined up and in place.

CHECKING FOR BLOCKAGES IN THE AUTO-EMPTY DOCK (BU3500 SERIES)

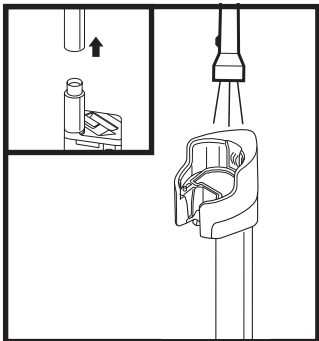

Checking for Blockages in the Charging Post:

1. Unplug the dock.
2. Remove the vacuum from the dock.
3. Press the latch on the back of the charging post and lift the post away from the dock.
4. Check the end of the charging post and top of the dock for any debris or blockages.

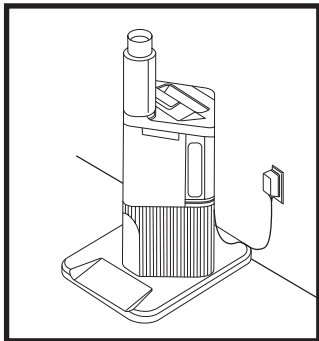

Checking for Blockages in the Dock:

1. Unplug the dock.
2. Remove the vacuum from the dock.
3. Remove the dust bin from the dock.
4. Check the exit for any debris or blockages.

TROUBLESHOOTING

WARNING: To reduce the risk of shock and unintended operation, turn off power and remove the battery before servicing.

Vacuum is not picking up debris. No suction or light suction. Third indicator light on hand vacuum is solid yellow. (Refer to Checking for Blockages section for more information.)

1. Dust cup may be full; empty dust cup.
2. Check floor nozzle for blockages; clear blockages if required.
3. Remove any string, carpet fibres, or hair that may be wrapped around the brushroll.
4. Check connection between hand vacuum and wand for blockages; clear blockages if required.
5. Check filters to see if they need cleaning. Follow instructions for rinsing and completely air-drying the filters before reinstalling them.

Vacuum lifts area rugs.

1. Make sure you are not engaging Boost mode. Take care when vacuuming area rugs or rugs with delicately sewn edges.
2. Turn off the unit to disengage from the carpet, then restart.

The brushroll in the floor nozzle doesn't spin.

1. Immediately turn off the vacuum. Remove any blockages before turning the vacuum back on. Make sure the hand vacuum is tilted back far enough for the brushroll to engage while in use.
2. If the floor nozzle has headlights and they are not illuminated, there is a connection issue between the hand vacuum, wand, and nozzle. Try detaching the parts, then reconnecting them.

Vacuum turns off on its own.

There are several possible reasons for the vacuum turning off on its own, including blockages, battery issues, and overheating. If vacuum turns off on its own, perform the following steps:

1. Turn on the vacuum and check the battery indicator lights on the hand vacuum. If recharging is needed, make sure vacuum power is off before connecting to battery charger.
2. Empty dust cup and clean filters (See the Cleaning the Dust Cup and Filter section).
3. Check wand, accessories, and inlet openings and remove any blockages.
4. Allow unit and battery to cool for at least 45 minutes, until they return to room temperature.
5. Press the On/Off switch to restart the vacuum.

Battery Indicator Lights on hand vacuum are flashing.

- Nozzle Ring Light flashes red (Fig. A): Nozzle clog. (See the Maintaining Your Vacuum section.) **Contact Customer Service at www.sharkclean.eu if you experience any of the indications listed below:**
- ECO and BOOST LEDs are flashing (Fig. B): Overcurrent or short.
- All LEDs except ECO are flashing (Fig. C): Motor is overheating.
- All LEDs except ECO and AUTO are flashing (Fig. D): Overspeed.
- All LEDs except BOOST and AUTO are flashing (Fig. E): Communication.
- AUTO and BOOST LEDs are flashing (Fig. F): There may be an electrical problem with the nozzle.

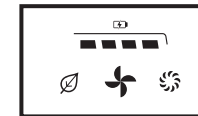

Fig. A

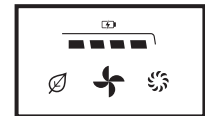

Fig. B

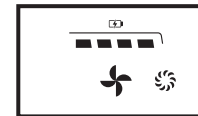

Fig. C

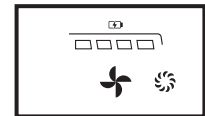

Fig. D

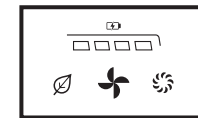

Fig. E

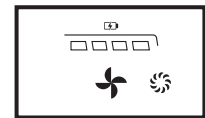
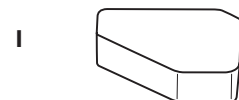
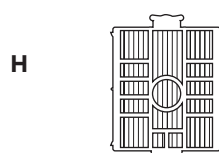
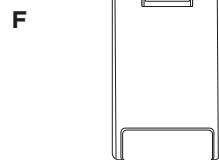
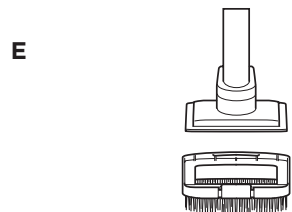
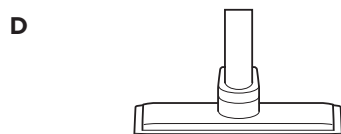
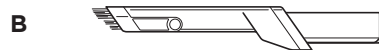

Fig. F

NOTE: If vacuum still does not operate properly, contact Customer Service at sharkclean.co.uk

- A** Crevice Tool
- B** Duster Crevice Tool
- C** Upholstery Tool
- D** Wide Upholstery Tool
- E** Pet Multi-Tool
- F** Replacement Battery
- G** Hand Vac Pre-Motor Filter
- H** Auto-Empty Dock
Post-Motor Anti-Allergen Filter (BU3500 SERIES)
- I** Auto-Empty Exhaust Foam Filter (BU3500 SERIES)



NOTE: Not all accessories come with all units. Please see the Quick Start Guide on the packaging box for your unit's configuration. To order additional accessories, visit sharkclean.co.uk.

MANUFACTURER'S GUARANTEE

The Shark Guarantee

When a consumer buys a product in the UK, they get the benefit of legal rights relating to the quality of the product (your "legal rights"). You can enforce your legal rights against your retailer, including Shark if you bought your appliance from sharkclean.co.uk. However, at Shark we are so confident about the quality of our products that we give the owner an additional, free parts and labour manufacturer's guarantee of up to 5 years (2 years for batteries).

The guarantee it comes with is an important consideration - and reflects how much confidence the manufacturer has in its product and manufacturing quality.

The manufacturer's guarantee does not affect your legal rights.

How long are new Shark machines guaranteed for?

Our manufacturer's guarantee lasts for one year from the date of purchase as standard, or for five years (two years for batteries) if you register your purchase with us within 28 days.

How do I register my Shark guarantee?

If you have purchased your Shark appliance directly from sharkclean.co.uk your guarantee is registered automatically. If you bought it from anywhere else in the UK, you can register your guarantee online within 28 days of purchase.

- To register online, please visit sharkclean.co.uk/register-guarantee or scan the QR code in your instruction booklet.
- Keep a note of the date you purchased the machine.

IMPORTANT:

- Keep your receipt if you bought your Shark appliance from anywhere except sharkclean.co.uk. You will need it to claim under your guarantee.
- The free Shark guarantee only applies in the UK.

What are the benefits of registering my free Shark guarantee?

When you register your guarantee, you will get an extra four years of cover (extra one year for batteries). We'll also have your details to hand if we ever need to get in touch. If you further agree to receive communications from us, you can also receive tips and advice on how to get the best out of your Shark appliance and hear the latest news about new Shark technology and launches.

What is covered by the free Shark guarantee?

Repair or replacement (at Shark's discretion) of your Shark machine, including all parts and labour.

What is not covered by the free Shark guarantee?

- Normal wear and tear.
- Accidental damage or faults caused by negligent use or care, misuse, neglect, careless operation or handling of the Shark appliance which is not in accordance with the Shark Operating Manual supplied with your machine.
- Damage caused by use of the Shark appliance for anything other than normal domestic household purposes.
- Damage caused by use of parts not assembled or installed in accordance with the operating instructions.
- Damage caused by use of parts and accessories which are not Shark Genuine Components
- Faulty installation (except where installed by Shark).
- Repairs or alterations carried out by parties other than Shark or its agents.

How can I claim under the free Shark guarantee?

Contact our customer service helpline on 0800 862 0453. For service hours please visit our website under 'Contact Us'. It's free to call, and you'll be put straight through to a Shark representative. You'll also find online support at support.sharkclean.co.uk. The Shark representative will go through some troubleshooting with you, and if we conclude that the item has failed, we will send you a replacement part or a returns label to send the defective item back to us free of charge. When you have delivered the defective product to us, we will send you a replacement.

Please remember that the item will need to be boxed when you return it to us. It can be any suitable box, it does not have to be the original packaging.

Where can I buy genuine Shark spares and accessories?

Shark spares and accessories are developed by the same engineers who developed your Shark appliance. You'll find a full range of Shark spares, replacement parts and accessories for all Shark machines at sharkclean.co.uk. Please remember that damage caused by the use of non-Shark spares may not be covered under your guarantee.

NOTES

A series of horizontal dotted lines for taking notes on page 18.

NOTES

A series of horizontal dotted lines for taking notes on page 19.



**SharkNinja Europe Ltd,
1st/2nd Floor Building 3150,
Thorpe Park, Century Way, Leeds,
England, LS15 8ZB, UK
+44 (0)800 862 0453
www.sharkclean.co.uk**

**SharkNinja Germany GmbH,
Rotfeder-Ring 9,
60327 Frankfurt am Main,
Germany**

Illustrations may differ from actual product. We are constantly striving to improve our products; therefore the specifications contained herein are subject to change without notice.

©2024 SharkNinja Operating LLC. FLOOR DETECT and SHARK are registered trademarks of SharkNinja Operating LLC in the United Kingdom.

BU3500UK_IB_MP_240322_Mv1
PRINTED IN CHINA

 @sharkcleaninguk

 @sharkcleanuk

 @sharkcleanuk