

QuickJack™ Portable Car Jack Setup and Operation Manual

Manual P/N 5900263 — Manual Revision B5 — Released November 2022

Models:

- 3500SLX
- 5000TL
- 7000TL
- 6000ELX
- 5000TLX
- 7000TLX

Original instructions in the English language.



A video of how to set up your **QuickJack** is available [online](#).

Always check for the latest revision of the QuickJack Setup and Operation Manual at quickjack.com.

QuickJack is designed and engineered by BendPak Inc. in Southern California, USA. Made in China.



IMPORTANT SAFETY INSTRUCTIONS, SAVE THESE INSTRUCTIONS!

Read the *entire contents* of this manual *before* installing, operating, servicing, or maintaining this lift. Failure to follow the instructions and safety precautions in this manual can result in serious injury or death. Make sure all other operators also read this manual. Keep the manual near the product for future reference. *By proceeding with setup and operation, you agree you fully understand the contents of this manual and assume full responsibility for product use.*****

Manual. QuickJack™ Portable Car Jack, *Setup and Operation Manual*, P/N 5900263, Manual Revision B5, Released November 2022.

Copyright. Copyright © 2022 by BendPak Inc. All rights reserved. You may make copies of this document if you agree that: you will give full attribution to BendPak Inc., you will not make changes to the content, you do not gain any rights to this content, and you will not use the copies for commercial purposes.

Trademarks. BendPak and the BendPak logo are registered trademarks of BendPak Inc. QuickJack and JackPak are trademarks of BendPak Inc. All other company, product, and service names are used for identification only. All trademarks and registered trademarks are the property of their respective owners.

Limitations. Every effort has been made to ensure complete and accurate instructions are included in this manual. However, product updates, revisions, and/or changes may have occurred since this manual was published. BendPak reserves the right to change any information in this manual without incurring any obligation for equipment previously or subsequently sold. BendPak is not responsible for typographical errors in this manual. The latest version of the manual for this product is **available on the QuickJack website**.

Warranty. The QuickJack warranty is more than a commitment to you: it is also a commitment to the value of your new product. For full warranty details and to register your new QuickJack product, contact your nearest QuickJack dealer or visit quickjack.com/warranty.

Safety. Your new product was designed and manufactured with safety in mind. Your safety also depends on proper training and thoughtful operation. Do not set up, operate, maintain, or repair the unit without reading and understanding this manual and the labels on the unit.

Owner Responsibility. In order to maintain your product properly and to ensure operator safety, it is the responsibility of the product owner to read and follow these instructions:

- Follow all setup, operation, and maintenance instructions.
- Make sure product setup conforms to all applicable local, state, and federal codes, rules, and regulations, such as state and federal OSHA regulations and electrical codes.
- Consult a qualified person or organization to address any special regional structural and/or seismic requirements specified by any other agencies and/or codes. The QuickJack must be installed on a flat surface which can support the load of the vehicle being lifted without subsidence or movement.
- Read and follow all safety instructions. Keep them readily available for operators.
- Make sure all operators are properly trained, know how to safely operate the unit, and are properly supervised.
- Do not operate the product until you are certain that all parts are in place and operating correctly.
- Carefully inspect the product on a regular basis and perform all maintenance as required.
- Service and maintain the unit only with approved replacement parts.
- Keep all instructions permanently with the product and make sure all labels are clean and visible.
- **Only use this product if it can be used safely!**

Unit Information. Enter the Model Number, Serial Number, and the Date of Manufacture from the label on your unit. This information is required for part or warranty issues.

Model: _____

Serial: _____

Date of Manufacture: _____

QUICKJACK™ 1645 Lemonwood Dr. Santa Paula, CA USA	
MODEL NUMBER / NUMÉRO DE MODÈLE	
DESCRIPTION	
LIFT CAPACITY (PAIR) / CAPACITÉ DE LEVAGE (PAIRE)	
DATE CODE / CODE DATE	UPC / CUP
SERIAL NUMBER NUMÉRO DE SÉRIE	⚠ DANGER! Disconnect Power Before Servicing Couper l'alimentation avant toute intervention.
CE EAC UK	
WARRANTY VOID IF DATA PLATE IS REMOVED GARANTIE NULLE SI LA PLAQUE DE DATE A ÉTÉ ENLEVÉE	
MADE IN CHINA / FABRIQUÉ EN CHINE PN 5905433	

Table of Contents

Introduction	3	Operation	35
Shipping	5	Maintenance	48
Safety	5	Troubleshooting	50
Components	8	Wiring Diagrams	53
Accessories	10	Labels	55
Specifications	11	Parts Sheets	58
FAQ	13	Declaration of Conformity	66
Setup Checklist	14	Maintenance Log	68
Setup	15	ALI Store	71

Introduction

This manual covers all models of the QuickJack portable car jack, which makes Vehicle maintenance in your garage or at the track fast and easy. QuickJack models include:

- **3500SLX**: Raises Vehicles up to 3,500 lbs. / 1,588 kg on a medium-length frame.
- **5000TL**: Raises Vehicles up to 5,000 lbs. / 2,267 kg on a longer frame.
- **7000TL**: Raises Vehicles up to 7,000 lbs. / 3,175 kg on a longer frame.
- **5000TLX**: Raises Vehicles up to 5,000 lbs. / 2,267 kg on an **extended** frame.
- **7000TLX**: Raises Vehicles up to 7,000 lbs. / 3,175 kg on an **extended** frame.
- **6000ELX**: Raises Vehicles up to 6,000 lbs. / 2,721 kg on an **extremely long** frame.

This manual is mandatory reading for all QuickJack users, including anyone who sets it up, operates it, maintains it, or repairs it. You can always find the latest version of the Manual on the **QuickJack Website**.

 **DANGER** Be very careful when setting up, operating, maintaining, or repairing your unit; failure to do so could result in property damage, product damage, injury, or (in very rare cases) death. Make sure only authorized personnel operate the unit. All repairs must be performed by an authorized technician. Do not make modifications to the unit; this voids the warranty and increases the chances of injury or property damage. Make sure to read and follow the instructions on the labels on the unit.

Keep this manual on or near your QuickJack so that anyone who uses or services it can read it.

For technical support, visit quickjack.com/support or email QuickJack Technical Support at support@quickjack.com. You can also request parts (be sure to have the serial and model numbers of your unit available).



IMPORTANT! PLEASE READ

Only raise your QuickJack Frames with a Vehicle on them!

The QuickJack is designed and engineered to be used with the weight of a Vehicle on it. You should only raise the QuickJack Frames with the weight of a Vehicle on them, *even the very first time you use them (with the exception of bleeding the Hydraulic Cylinders)*. There is simply no reason to raise your QuickJack Frames unless there's a Vehicle on them.

Why are we telling you to do it this way? Because your QuickJack Frames may occasionally become stuck up in the air if you raise them without the weight of a Vehicle. There is nothing wrong with them if this happens, and the issue can be quickly and easily fixed, it's just that they are designed and engineered to work with the weight of a Vehicle. ***Only raise your QuickJack Frames with a Vehicle on them.***

And since we have your attention...

Do *not* remove your Vehicle's tires then lower the QuickJack to the ground.

The QuickJack requires space between the ground and your Vehicle to build up enough force to raise a Vehicle. It cannot raise a full load from a completely flat starting position.



**Do
Not
Do
This!**

This is not a problem in normal operation, as the Vehicles you want to raise are being held well above the ground by their tires. The problem generally happens when people lower the QuickJack to a completely flat position with the Vehicle's tires removed.

What do you do if either of these problems happens to you? Refer to [Troubleshooting](#).

Shipping

Your QuickJack was carefully checked before shipping. Nevertheless, you should thoroughly inspect the shipment **before** you sign to acknowledge that you received it.

When you sign the bill of lading, it tells the carrier that the items on the invoice were received in good condition. **To protect yourself, do not sign the bill of lading until after you have inspected the shipment.** If any of the items listed on the bill of lading are missing or are damaged, do not accept the shipment until the carrier makes a notation on the bill of lading that lists the missing and/or damaged goods.

If you discover missing or damaged goods **after** you receive the shipment and have signed the bill of lading, notify the carrier at once and request the carrier to make an inspection. If the carrier will not make an inspection, prepare a signed statement to the effect that you have notified the carrier (on a specific date) and that the carrier has failed to comply with your request.

It is difficult to collect for loss or damage after you have given the carrier a signed bill of lading. If this happens to you, file a claim with the carrier promptly. Support your claim with copies of the bill of lading, freight bill, invoice, and photographs, if available. Our willingness to assist in helping you process your claim does not make us responsible for collection of claims or replacement of lost or damaged materials.

Safety

Refer to ANSI/ALI ALIS Standard (R2015) *Safety Requirements for Installation and Service of Automotive Lifts* for more information about safely installing your QuickJack.

Important **Before** proceeding any further, we suggest checking the **QuickJack Website** to ensure you have the latest version of the manual for your QuickJack.

 **WARNING** **California Proposition 65:** This product can expose you to chemicals including styrene and vinyl chloride which are on the list of over 900 chemicals identified by the State of California to cause cancer, birth defects or reproductive harm. Always use this product in accordance with BendPak's instructions. For more information, visit www.p65warnings.ca.gov.

Important Safety Instructions

When using your garage equipment, basic safety precautions should always be followed, including:

1. Read all instructions.
2. Do not touch hot parts; you could be burned. Always use care with the equipment.
3. Do not operate equipment with a damaged cord or if the equipment has been dropped or damaged — until it has been examined by a qualified service person.
4. Do not let a cord hang over the edge of a table, bench, or counter or come in contact with hot manifolds or moving fan blades.
5. If an extension cord is necessary, a cord with a current rating equal to or greater than that of the equipment should be used. Cords rated for less current than the equipment may overheat. Care should be taken to arrange the cord so that it will not be tripped over or pulled.

-
6. Always unplug equipment from electrical outlet when not in use. Never use the cord to pull the plug from the outlet. Grasp plug and pull to disconnect.
 7. Let equipment cool completely before putting away. Loop cord loosely around equipment when storing.
 8. To reduce the risk of fire, do not operate equipment in the vicinity of open containers of flammable liquids (gasoline).
 9. Adequate ventilation should be provided when working on operating internal combustion engines.
 10. Keep hair, loose clothing, fingers, and all parts of your body away from moving parts.
 11. To reduce the risk of electric shock, do not use on wet surfaces or expose to rain.
 12. Use only as described in this manual. Use only manufacturer's recommended attachments.
 13. Always wear safety glasses. Everyday glasses only have impact resistant lenses, they are not safety glasses.
 14. To reduce the risk of injury, close supervision is necessary when this product will be used around children.
 15. To reduce the risk of injury, never overload the drawers or shelves. Refer to loading instructions.
 16. To reduce the risk of electric shock or fire, never overload receptacles. Refer to markings for the proper load on receptacles.

Save these instructions!

QuickJack Safety Information





Please note the following:

- The product is a portable car jack. Use it only for its intended purpose.
- Read this manual thoroughly before installing, operating, servicing, or maintaining your QuickJack.
- The product should only be operated by authorized personnel.
- Do not make any modifications to the product.
- ***QuickJack is approved for indoor installation and use only.*** Outdoor installation is prohibited. Your QuickJack is portable, however, so if you end up taking it outdoors, remember to protect it from the weather (for example, from falling dirt, rain, sleet, and snow).
- Never exceed the rated capacity of the jack.
- Make sure all operators read and understand this *Setup and Operation Manual*. Keep the manual near the device at all times.
- Do not use the product while tired or under the influence of drugs, alcohol, or medication.
- Make a visual inspection of the product before using it ***each time***. Check for damage or missing parts. Do not use the product if you find any of these issues. Instead, stop using it, then contact QuickJack at quickjack.com/support or support@quickjack.com.
- Make a ***thorough*** inspection of the product at least once a year. Replace any damaged or severely worn electrical cables, Hydraulic Hoses, decals, or warning labels. Do not use the product until damaged or worn items have been replaced.
- You ***must*** wear OSHA-approved (publication 3151) personal protective equipment at all times when installing, using, maintaining, or repairing the QuickJack: leather gloves, steel-toed work boots, eye protection, back belts, and hearing protection.
- Remove all jewelry while working with the product. Dangling jewelry can get caught in moving parts; metal jewelry can conduct electricity. Avoid wearing loose-fitting clothing.

- While handling a Hydraulic Cylinder or a Hydraulic Hose, also wear gloves. In rare cases, a needle-like stream of hydraulic fluid (even at low pressure) can penetrate fingers, hands, or arms; such a puncture can feel like a bite, electric shock, or a prick. While it may seem like a minor issue, any amount of Hydraulic Fluid injected into the human body is a serious issue. Anyone suffering such a puncture wound should be **immediately** taken to a hospital emergency room to determine the extent of the injury. Explain the circumstances of the injury to the attending physician, including what kind of Hydraulic Fluid was involved. Do not assume a puncture wound that could have been caused by Hydraulic Fluid is a minor issue; it could be life threatening.
- Floor surface must be dry, flat, and have a minimum compressive strength of 500 PSI. The Lift must not sink into the ground or crack the surface under the weight of the Vehicle.
- Avoid using an extension cord; they can overheat. If you must use an extension cord, make sure it is No. 14 AWG / 2.5mm² minimum.
- Take care locating the electrical cable and Hydraulic Hoses; you do not want them driven over or stepped on.
- Clear the area if a Vehicle is in danger of falling off the jack.
- **Make sure both Lock Bars are engaged before nearing an elevated Vehicle.**
- *As an added precaution, you must **always** use auxiliary safety stands under the Vehicle while elevated on both QuickJack Frames.*

Symbols

Following are the symbols used in this manual:

-  **DANGER** Calls attention to an immediate hazard that **will** result in death or severe injury.
-  **WARNING** Calls attention to a hazard or unsafe practice that **could** result in death or severe personal injury.
-  **CAUTION** Calls attention to a hazard or unsafe practice that could result in minor personal injury, product, or property damage.
-  **Tip** Calls attention to information that can help you use your QuickJack better.

Liability Information

BendPak assumes **no** liability for damages resulting from:

- Use of the equipment for purposes other than those described in this manual.
- Modifications to the equipment without prior, written permission from BendPak.
- Injury or death caused by modifying, disabling, overriding, or removing safety features.
- Damage to the equipment from external influences.
- Incorrect operation of the equipment.

Components

The following image shows the main components of a QuickJack.

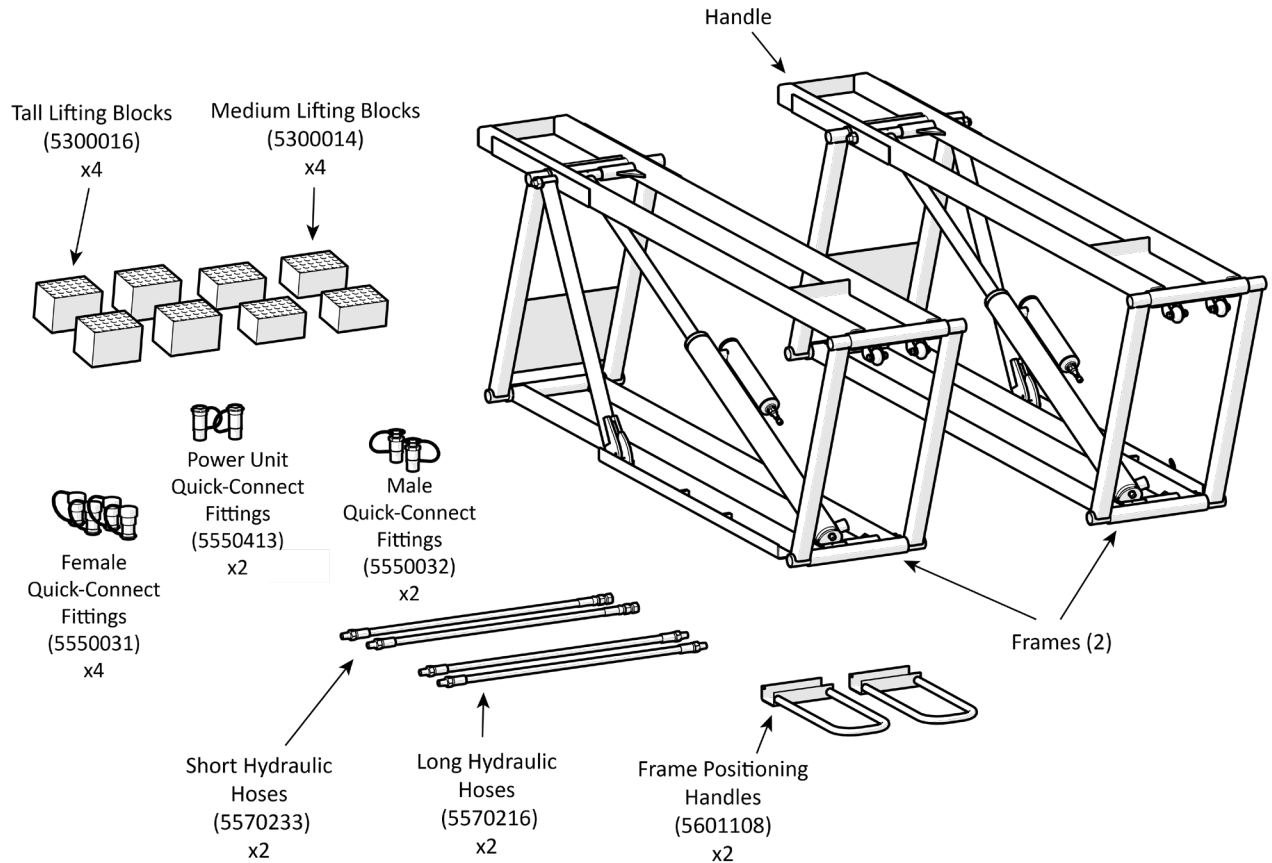

Not all components shown. Not necessarily drawn to scale.

QuickJack components include:

- **Two QuickJack Frames.** The Frames, working together, raise and lower Vehicles. The two Frames are **not** interchangeable. The Lock Bars, described below, must be on the **outside** when you orient the Frames.
- **Eight rubber Lift Blocks.** Four are medium height (2 inches) and four are tall (3 inches high). The Lift Blocks can be placed in different locations in the Receiver Trays, allowing you to hit the factory-recommended Lifting Points on a wide variety of Vehicles. *Always use Lift Blocks; do not raise a Vehicle on just the QuickJack Frames.*

Note: You can stack one medium and one tall block together, but not more than that.

If you have a Vehicle with a unibody/pinch-weld frame, QuickJack recommends ordering optional Pinch-Weld Blocks, **available on the QuickJack website**. If you have an SUV or truck, there is an SUV and Light Truck Adapter available for these Vehicles, also on the QuickJack website.

If you are going to be raising Vehicles with very low ground clearance, low-profile Lift Blocks are available as **Accessories**.

- **One Power Unit** (includes Pendant Control). *Not shown.* Provides power to the QuickJack Frames. There are three Power Units available: 110 VAC, 220/240 VAC, CE-approved 220 VAC. CE/UKCA approved Power Units part numbers 5585360 / 5585760 / 5585739.
- **Parts Bag.** Holds the components used during setup; includes the Hydraulic Fittings.
- **Two Power Unit Quick-Connect Fittings.** One end connects to the Long Hydraulic Hose, while the other end connects to a Hydraulic Port on the Power Unit.
- **Two Male Quick-Connect Fittings.** One end connects the Short Hydraulic Hose, and the other end connects to the Long Hydraulic Hose.
- **Four Female Quick-Connect Fittings.** One goes on each end of the Long Hydraulic Hose. Two per each Long Hydraulic Hose.
- **Two Short Hydraulic Hoses.** Connect on one end to the Hydraulic Cylinder on each Frame and on the other end to one of the Long Hydraulic Hoses. Note that the Short Hydraulic Hoses **must** be routed **under** the bottom of the Frame, *never over the Frame.*
- **Two Long Hydraulic Hoses.** Connect on one end to the Power Unit and on the other end to one of the Short Hydraulic Hoses.



Tip

To move your QuickJack components: disconnect the Long Hydraulic Hoses either at the Power Unit or at the Short Hydraulic Hoses. This is easier than trying to move the QuickJack with all components connected.

- **Two Frame Positioning Handles.** Used to easily move the QuickJack Frames, usually to position the Frames under the Vehicle's factory-recommended Lifting Points.
- **Lock Bars.** The two Lock Bars, one on each QuickJack Frame, hold the Frames in position when they are raised.
Only leave the QuickJack either fully lowered or engaged on a Locking Position.
- **Hydraulic Cylinder** and **Air Cylinder.** Each QuickJack Frame has one Hydraulic Cylinder and one Air Cylinder. The Hydraulic Cylinder receives Hydraulic Fluid from the Power Unit, which is used to move the Frames up and down. The Air Cylinder acts like an air spring, which means they assist in lowering the Frames.
- **Wheels.** The two Wheels on the non-sticker end of each QuickJack Frame allow you to easily move the Frame to a different location. Note that the Wheels and the weight of the Frame can leave marks on some floors, so be careful using them.
- **Handles.** On the sticker end of each QuickJack Frame is an opening that can be used as a Handle when you are moving the Frame. To pick up a Frame by its Handle, with one hand raise the Frame just off the ground under the large yellow sticker, then put the other hand in the Handle and continue to raise the Frame.



WARNING

Be very careful when putting down the Frame; you do not want to crush your fingers.

Accessories

Note that the following accessories are **not** ALI-certified.

Crossbeam Adapter

The Crossbeam Adapter lets you hit the Lifting Points with uneven Frames/Lifting Points.

The Crossbeam Adapter components include: one Crossbeam, two Crossbeam Lift Pads, two Crossbeam Bases, and two Round Lift Pads and Base Adapters. Visit the [Accessories page of the QuickJack website](#) for more information.

SUV and Light Truck Adapter Kit

The optional SUV and Light Truck Adapter Kit increases the service capability of your QuickJack by providing stackable Lift Blocks that mount inside the Receiver Trays; for 5000TL/TLX and 7000TL/TLX models.

The Adapter Kit includes: four low-profile, round Contact Pads, four Bases that accommodate the Contact Pads with Extenders, and four 3-inch Extenders. Visit the [Accessories page of the QuickJack website](#) for more information.

Frame Extension Kit

The Frame Extension Kit is a pair of QuickJack frame extenders that increase the lift-point spread for **5000TL** and **7000TL** models by 6 inches, for a total lift point spread of 66 inches. They fit snugly into your QuickJack with no setup required and can be easily taken off and put back on. Visit the [Accessories page of the QuickJack website](#) for more information.

Motorcycle Lift Adapter Kit

The Motorcycle Lift Adapter Kit lets you add a platform on top of your QuickJack Frames, converting it into a motorcycle lift. This product is not CE certified.

The Adapter Kit includes: a tread plate, heavy-duty tie-down rings, a support axle, a large clamp with treaded-rubber padding, and an easy-to-use crank for wheel security. Visit the [Accessories page of the QuickJack website](#) for more information.

Ranger RML-1100 Motorcycle Jack

The Ranger RML-1100 Motorcycle Jack is ideal for servicing motorcycles and ATVs up to 1,100 lbs. / 499 kg. It is the perfect accessory for the QuickJack Motorcycle Lift Adapter Kit. This product is not CE certified. Visit the [Accessories page of the QuickJack website](#) for more information.

JackPak

The portable JackPak lets you add air to the Air Cylinders on each QuickJack Frame. It also includes additional features for roadside assistance and emergencies. Refer to [jackpak.com](#) for more information.

Specifications

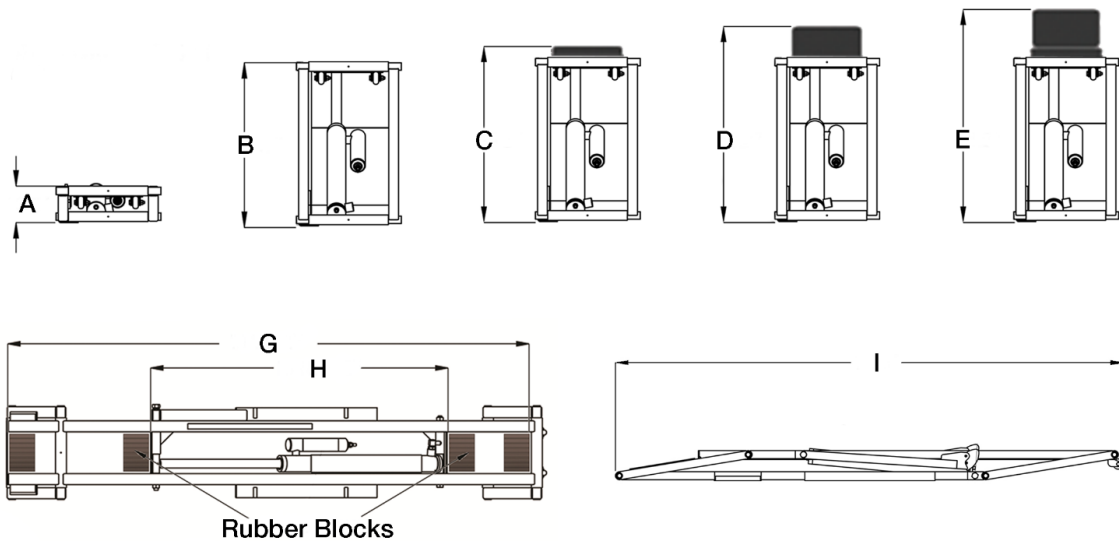

Specifications are subject to change without notice.

Model	3500SLX	5000TL	7000TL
Lifting capacity	3,500 lbs / 1,588 kg	5,000 lbs / 2,268 kg	7,000 lbs / 3,175
A Lowered height (frame only)	3" / 76 mm	3" / 76 mm	3.5" / 89 mm
B Height, frame only *	16" / 404 mm	20.25" / 512 mm	20.75" / 527 mm
C Height, small blocks	17" / 431 mm	20.5" / 520 mm	21" / 533 mm
D Height, tall blocks	18" / 457 mm	21.5" / 546 mm	21.75" / 552 mm
E Height, stacked blocks	21" / 533 mm	24" / 610 mm	24.5" / 622 mm
F Frame width	10.5" / 267 mm	11" / 279 mm	12.5" / 318 mm
G Max lifting point spread	50.5" / 1,283 mm	60" / 1,524 mm	60" / 1,524 mm
H Min lifting point spread	27" / 686 mm	37" / 940 mm	37" / 940 mm
I Frame length	62.5" / 1,588 mm	70" / 1,778 mm	70.75" / 1,797mm
Individual frame weight	60 lbs / 27 kg	78 lbs / 35 kg	98 lbs / 45 kg
Power unit weight (no fluid)	50 lbs / 23 kg	50 lbs / 23 kg	50 lbs / 23 kg
Power Unit PRV setting	2,400 psi	2,400 psi	2,400 psi
Maximum Operating Pressure	2,100 psi	2,100 psi	2,100 psi
Sound (when raising/lowering)	<70 dBA	<70 dBA	<70 dBA
Maximum allowed wind speed	<60 mph / <96.5 kph	<60 mph / <96.5 kph	<60 mph / <96.5 kph

For power requirements see [Connect the Power Unit to a Power Source](#).

* For reference purposes only; **do not** raise a Vehicle without Lift Blocks.

Height values may be .25 in / 7 mm different if measurement done with mechanism at full rise or on top lock.

Measurements may be up to 3 percent different based on amount of weight on lift, weight distribution, and manufacturing tolerances.

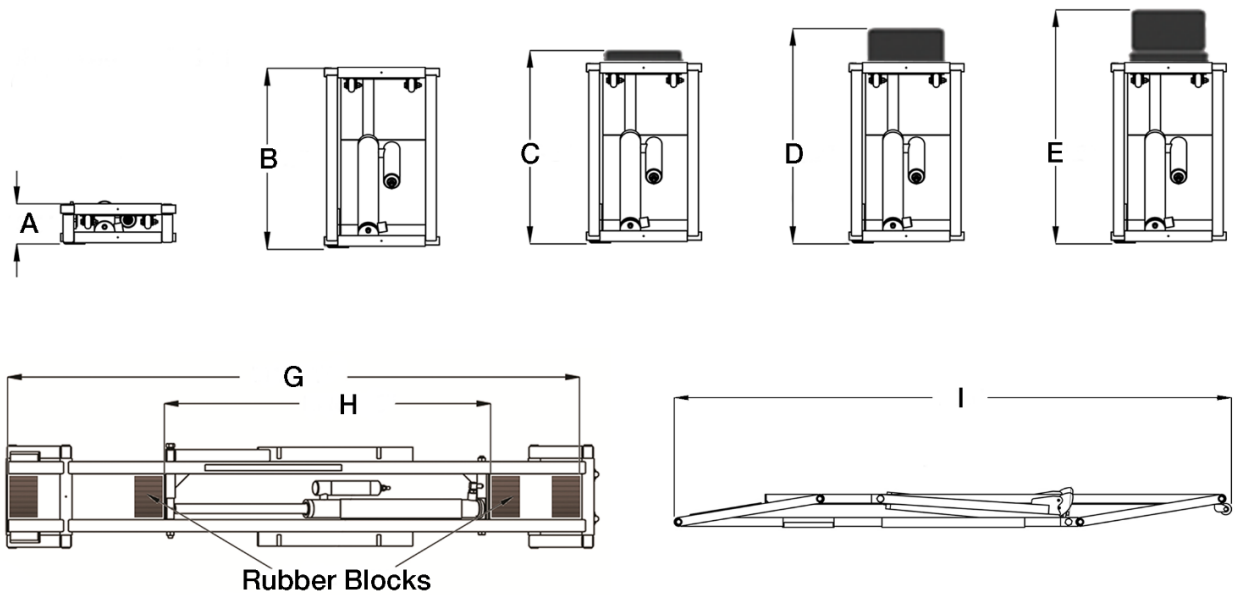

Specifications are subject to change without notice.

Model	6000ELX	5000TLX	7000TLX
Lifting capacity per pair	6,000 lbs / 2,722 kg	5,000 lbs / 2,268 kg	7,000 lbs / 3,175 kg
A Lowered height (frame only)	3.5" / 89 mm	3" / 76 mm	3.5" / 89 mm
B Height, frame only *	20.75" / 527 mm	20.25" / 512 mm	20.75" / 527 mm
C Height, small blocks	21" / 533 mm	20.5" / 520 mm	21" / 533 mm
D Height, tall blocks	21.75" / 552 mm	21.5" / 546 mm	21.75" / 552 mm
E Height, stacked blocks	24.5" / 622 mm	24" / 610 mm	24.5" / 622 mm
F Frame width	12.5" / 318 mm	11" / 279 mm	12.5" / 318 mm
G Max lifting point spread	76" / 1,930 mm	66" / 1,676 mm	66" / 1,676 mm
H Min Lifting point spread	53" / 1,346 mm	43" / 1,092 mm	43" / 1,092 mm
I Frame length	86.75" / 2,203 mm	76" / 1,930 mm	76" / 1,930 mm
Individual frame weight	112 lbs / 51 kg	81.5 lbs / 37 kg	103 lbs / 47 kg
Power unit weight (no fluid)	50 lbs / 23 kg	50 lbs / 23 kg	50 lbs / 23 kg
Power Unit PRV setting	2,400 psi	2,400 psi	2,400 psi
Maximum Operating Pressure	2,100 psi	2,100 psi	2,100 psi
Sound (when raising/lowering)	<70 dBA	<70 dBA	<70 dBA
Maximum allowed wind speed	<60 mph / <96.5 kph	<60 mph / <96.5 kph	<60 mph / <96.5 kph

For power requirements see [Connect the Power Unit to a Power Source](#).

* For reference purposes only; **do not** raise a Vehicle without Lift Blocks.

Height values may be .25 in / 7 mm different if measurement done with mechanism at full rise or on top lock.

Measurements may be up to 3 percent different based on amount of weight on lift, weight distribution, and manufacturing tolerances.

Frequently Asked Questions

Question: What kinds of Vehicles can I raise using my QuickJack?

Answer: A wide variety. The two main criteria are: is the curb weight of the Vehicle under the weight capacity of your QuickJack and do the QuickJack's Lift Blocks hit the Vehicle's factory-recommended Lifting Points? If the answers are yes, and for most Vehicles the answers are yes, then you can raise the Vehicle.

Q: What if I want to raise a Vehicle that is slightly over the weight capacity of my QuickJack?

A: This is **not** an intended use of the product. We strongly recommend against trying to raise a Vehicle that is heavier than the rated capacity of your QuickJack.

Q: Do the QuickJack Frames have a "left" and "right" orientation?

A: Yes. Put your QuickJack Frames next to each other with both Lock Bars on the outside and the *end with the QuickJack Sticker away from you.*

Q: Can I use my QuickJack outdoors?

A: No. The QuickJack is approved for indoor installation and use only. **Outdoor installation is prohibited.** Your QuickJack is portable, however, so if you end up taking it outdoors, remember to protect it from the weather (for example, from falling dirt, rain, sleet, and snow).

Q: Can I drive on the QuickJack Frames?

A: A Vehicle can be **above** your QuickJack Frames (this is normal operation, in fact), but **do not** drive a Vehicle **on** the QuickJack Frames or the Hydraulic Hoses; this damages them.

Q: What happens if I raise a Vehicle on my QuickJack but **do not** leave it in a locked position?

A: First, do not do this; it is a safety hazard. Second, because the QuickJack is not in a locked position, the weight of the Vehicle will eventually lower it to the ground. Always follow this rule: **if you raise a Vehicle, engage it on a locking position or lower it back to the ground.**

Q: How long can I leave a Vehicle raised on my QuickJack?

A: As long as you want, **if it is engaged on a locking position.** Once your QuickJack is engaged on a locking position, gravity holds it in place; a loss of power or leaking Hydraulic Fluid would **not** cause the QuickJack to lower.

Q: Anything else I should know about my QuickJack?

A: Two things. First, **do not raise your QuickJack Frames to full height with no Vehicle on it.** QuickJack Frames are built to hold the weight of a Vehicle; they may get stuck at full rise if there is no weight on them. *Always raise your QuickJack Frames with a Vehicle on them.* Second, do not try to raise a Vehicle from no net rise (meaning, if you lower the QuickJack Frames to the ground while the Vehicle's tires are removed). QuickJack needs some space to build up enough force to raise a Vehicle.

Setup Checklist

Following are the steps needed to install a QuickJack. Perform them in the order shown.

- 1. Review the setup Safety Rules.
- 2. Make sure you have the necessary Tools.
- 3. Select the setup Site.
- 4. Unpack the Components that came with the QuickJack.
- 5. Make sure there is adequate Clearance on all sides and above.
- 6. Locate and examine the Air and Hydraulic Cylinders.
- 7. Install the Hydraulic Elbow Fittings.
- 8. Prepare the Short Hydraulic Hoses.
- 9. About Thread Sealants.
- 10. Understand Quick-Connect Fittings.
- 11. Prepare and connect the Long Hydraulic Hoses.
- 12. Pressurize the Air Cylinders.
- 13. Find a location for the Power Unit.
- 14. Install Hydraulic Fittings on the Power Unit.
- 15. Connect the Power Unit to a Power Source.
- 16. Fill the Hydraulic Fluid Reservoir.
- 17. Check the Breather Valve.
- 18. Connect the Hydraulic Hoses.
- 19. Bleed the Hydraulic Cylinders.
- 20. Review the Final Checklist.
- 21. Test the QuickJack.
- 22. Leave the Manual for the owner/operator.

Setup

This section describes how to set up your QuickJack.

⚠ WARNING *Use only the factory-supplied parts that came with your QuickJack.* If you use any attachments, accessories, or configuration modifying components that are located in the load path and/ or affect operation of the Lift, affect the Lift electrical listing, or affect the intended Vehicle accommodation, and if they are not certified for use with this Lift, then you void the warranty of your QuickJack as well as compromising the safety of everyone who sets up or uses the Lift. If you are missing parts, visit quickjack.com/support or contact QuickJack Technical Support at support@quickjack.com, or call **(888) 262-3880** or **(805) 933-9970**.

Your QuickJack is supplied with setup instructions that meet the criteria set by the latest version of the American National Standard “Automotive Lifts – Safety Requirements for Construction, Testing, and Validation” ANSI/ALI ALCTV.

Setup Safety Rules

When setting up a QuickJack, your safety depends on proper training and thoughtful operation.

⚠ WARNING Always use proper tools, such as a forklift or shop crane, to move heavy components. Do not install this equipment without reading and understanding this manual and the labels on the unit.

BendPak recommends referring to the ANSI/ALI ALIS Standard (Current Version) *Safety Requirements for Installation and Service* for more information about safely setting up, using, and servicing your QuickJack.

Pay attention at all times during setup. Use appropriate tools and equipment. Stay clear of moving parts. Keep hands and fingers away from pinch points.

⚠ WARNING You must wear protective equipment at all times during setup: leather gloves, steel-toed work boots, eye protection, back belts, and hearing protection.

Tools

You need the following tools to set up your QuickJack:

- Metric and SAE hex key set
- Metric and SAE socket and ratchet set
- Metric and SAE Combination wrench set
- 8 or 10 inch Adjustable wrench
- Screwdriver set



Tip Keep a rag handy during setup; Hydraulic Fluid sometimes leaks.

At some point during setup, you will need to provide some air pressure (up to 50 psi, for the Air Cylinder) and 2.1 quarts / 2 liters of Hydraulic Fluid.

Selecting a Site

Keep the following in mind when selecting a site for your QuickJack:

- **Enough space.** Make sure there is adequate space for the QuickJack and the Vehicles you will be raising.
- **Radial Shift.** When you raise your QuickJack with a Vehicle on it, the geometry of the Frames moves the Vehicle up at a slight angle, towards the sticker end of the QuickJack; refer to the graphic in **Unpacking**. Radial shift is always towards the sticker end of the QuickJack, no matter which way the Vehicle is facing.

Radial shift can be anywhere from 11 to 15 inches, depending on QuickJack model.

Make sure to account for radial shift when choosing where to set up and use your QuickJack

- **No overhead obstructions.** Make sure your site is free of overhead obstructions such as heaters, building supports, electrical lines, low-hanging lights, and so on. We recommend leaving at least three feet above the top of the Vehicle when raised on the QuickJack.
- **Level floor.** Inspect the floor and check for defective concrete or asphalt. Make sure the floor is dry, level, and has a minimum compressive strength of 500 psi (3.5N/mm²). The Lift must not sink into the ground or crack the surface under the weight of the Vehicle.
- **Power in the right place.** You will need to have a power source for your Power Unit. If you are using 110 or 208 - 240 VAC power, the Power Unit must be close enough to the power source for the cord to reach.

 **WARNING** Do not set up or use a QuickJack on a surface with 3° of slope or more, as this could lead to personal injury or death if a raised Vehicle were to fall off the QuickJack. The greater the slope, the more likely the Vehicle will become unbalanced and fall off the QuickJack, which could damage the Vehicle and injure anyone in the area.

Unpacking

Open the boxes and arrange the QuickJack components where you will be setting them up.

The components needed to set up a QuickJack:

- **Box 1.** Includes the Left Frame.
- **Box 2.** Includes the Right Frame.
- **Box 3.** Includes the Power Unit (Voltage decided at time of purchase), Parts Bag, Hydraulic Hoses, 4 Medium Lifting Blocks, and 4 Tall Lifting Blocks.

⚠ WARNING Your two QuickJack Frames are similar, but they are **not** interchangeable. Always line up your Frames as parallel to each other as the Lifting Points will allow, with the **Lock Bars on the outside**, as shown below.

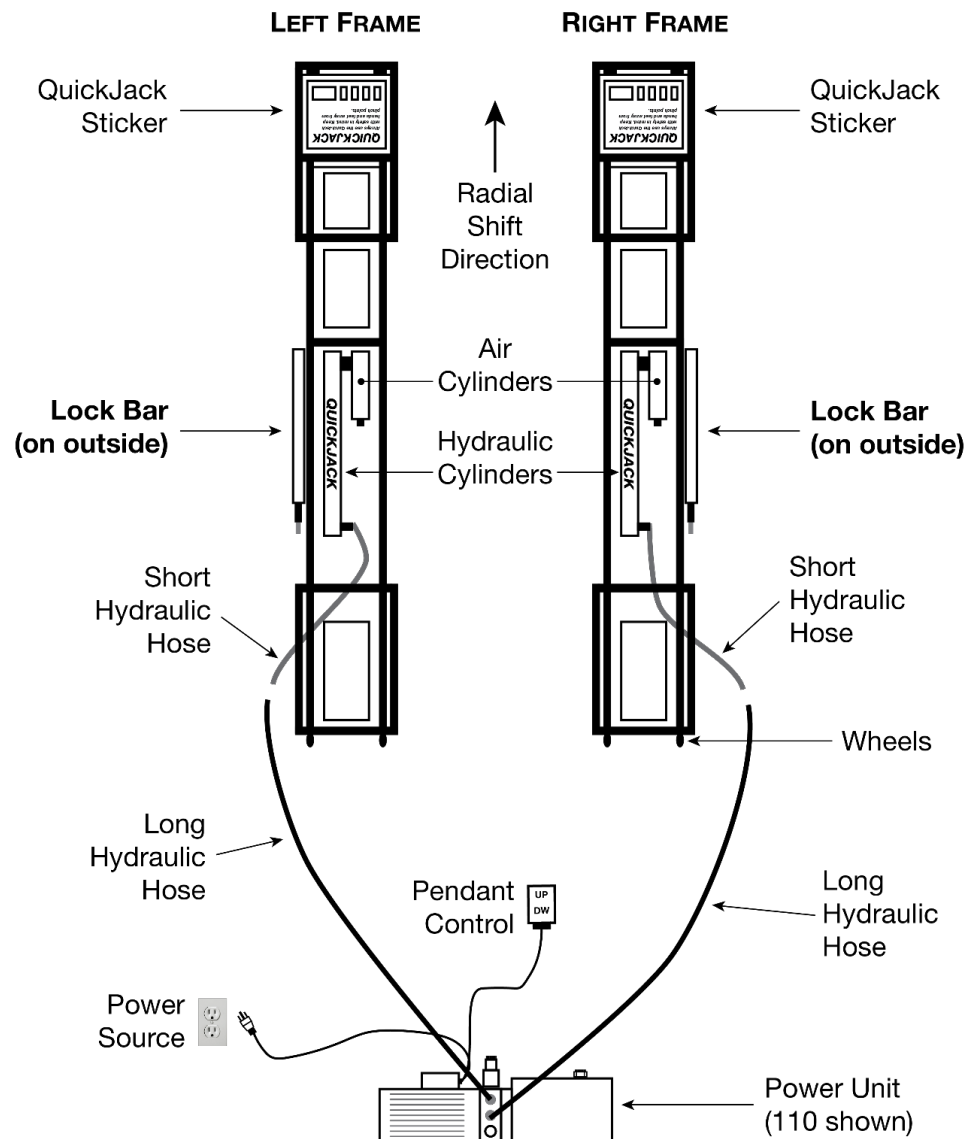

⚠ CAUTION Be sure to route the Short Hydraulic Hoses **under** the QuickJack Frames. If they are routed over the QuickJack Frames, the QuickJack will not work correctly and the Hoses could be damaged.

Clearances

For safety purposes, a certain amount of clear space around the Frames is **required**.

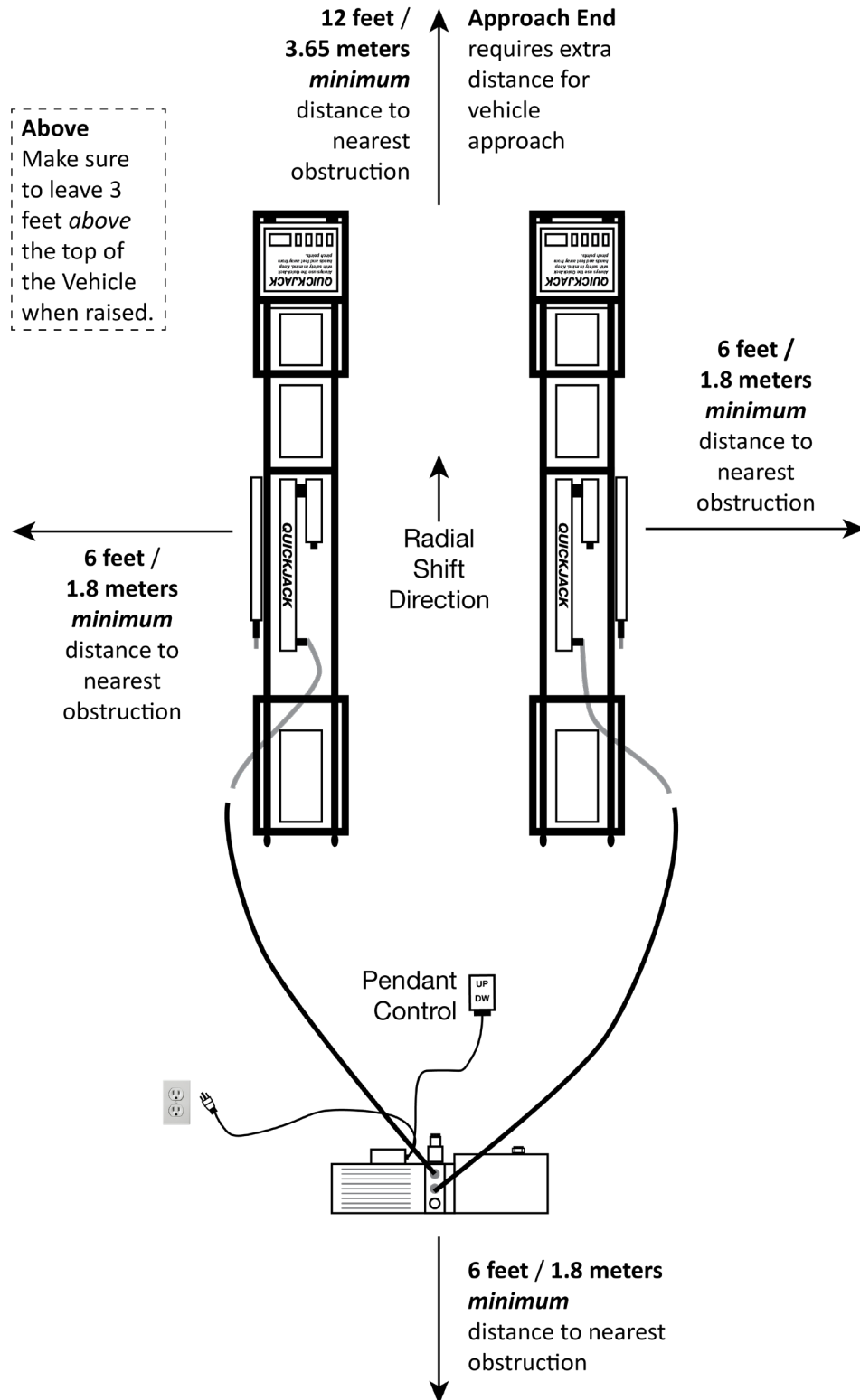

Vehicle approach must be opposite Power Unit. Do not drive Vehicle on Hydraulic Hoses, Power Unit, or QuickJack Frames. **Always** place the Power Unit and Pendant in a position so that the Operator has a clear view of **both Frames** while operating the QuickJack.

Air and Hydraulic Cylinders

Each QuickJack Frame has one Air Cylinder and one Hydraulic Cylinder.

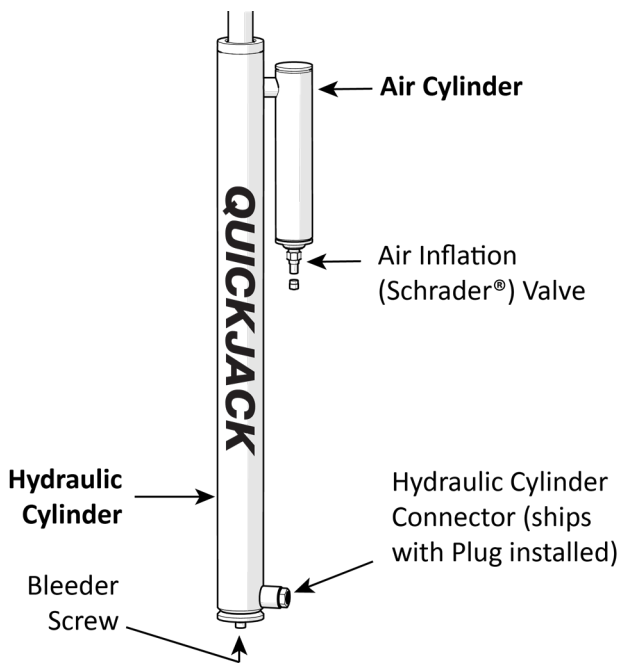

The components of the Air and Hydraulic Cylinders are:

- **Air Inflation Valve.** Used to add air pressure to the Air Cylinder. Comes with the appropriate valve (also called a Schrader® valve) installed.
- **Hydraulic Cylinder Connector.** Hydraulic Elbow Fitting attaches here. Use a 6 mm hex key to remove the shipping plug before installing the Hydraulic Elbow Fitting.

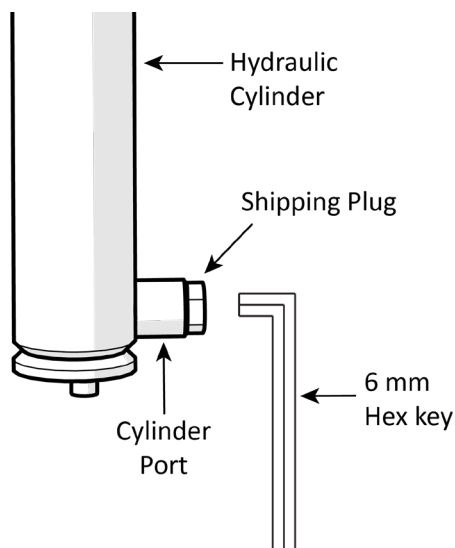

- **Bleeder Screw.** Used to “bleed” the air from the Hydraulic System, if necessary. Refer to [Troubleshooting](#) for more information.

Installing the Hydraulic Elbow Fittings

You need to install one Hydraulic Elbow Fitting (5550103) on each Hydraulic Cylinder.



Tip Raising the QuickJack Frame and putting a Lift Block under it or manually raising the Platform to a locking position can provide a little bit of extra room, making it easier to secure the Hydraulic Elbow Fitting.

To install the Hydraulic Elbow Fittings:

1. Remove the shipping plug from the Hydraulic Cylinder Port using a 6 mm Hex Key.
2. Take a Hydraulic Elbow Fitting from the Parts Bag and attach the ORB end into the Hydraulic Cylinder Port.

Important: Do *not* use Thread Sealant on either end of the Hydraulic Elbow Fitting.

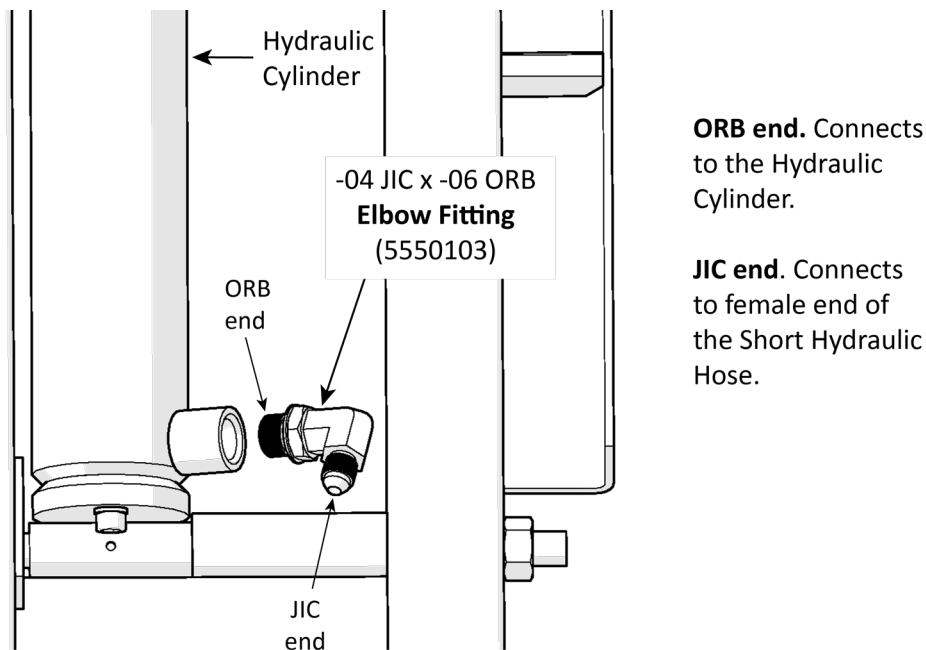

Drawing shows the hydraulic connections to make to the bottom of the Hydraulic Cylinder. Not all components are shown.

3. Position the threaded fitting end as shown above; accessible but not pointed up.
You want the threaded fitting end accessible but *not* pointed **up**, as the Short Hydraulic Hose would then angle up and could possibly impact the underside of a Vehicle.
4. Turn the Nut until fully snug.
5. Perform the same process for the Hydraulic Cylinder on the other QuickJack Frame.

About Thread Sealants

Your QuickJack comes with a bottle of Liquid Thread Sealant. Thread Sealant lubricates and fills the gaps between the Fitting threads, and leaves no residue that could contaminate the Hydraulic Fluid.

When Hydraulic Fittings are assembled and tightened properly, there should be no Hydraulic Fluid leaks during equipment operation and no internal fluid contamination to disrupt the performance of your QuickJack.

The same goes for Thread Seal Tape (like Teflon® Tape) or Liquid TPFE (Thread Sealer). Both are approved Thread Sealants for QuickJack, and if used correctly, there should be no evidence of Hydraulic Fluid leaks during equipment operation or Hydraulic Fluid contamination that could cause equipment malfunction.

To apply Liquid Thread Sealant:

1. Make sure the Fittings and connectors you are going to use are clean and dry.

If you are adding Thread Sealant to a Fitting or connector that has already been used with a different sealant, use a wire brush to thoroughly remove the old sealant before adding more.

2. Apply a small amount of Thread Sealant to the first four threads (skipping the first thread) of the Fitting.

 **WARNING** Make sure to wear the proper protective equipment when handling Thread Sealant.

You only need a small amount because the sealant spreads to the other threads as it is tightened into place. If you put too much, the excess liquid will be pushed out when the Fitting is tightened; use a rag to wipe the excess.

3. Hand tighten the Fitting into the connector, then fully secure by making 2-3 full turns with the appropriately sized wrench.
4. Allow a minimum of **24 hours** curing time, before pressurizing the system.

Liquid Thread Sealant or Thread Seal Tape?

We have found that much QuickJack criticism or warranty-related incidences were caused by Hydraulic Fluid contamination, with evidence of Thread Seal Tape particles inside the Power Unit components and the Reservoir.

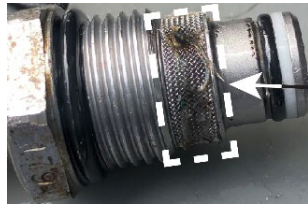

Thread Seal Tape stuck to Power Unit components

In an attempt to prevent this contamination, we have begun using a Liquid Thread Sealant in lieu of Thread Seal Tape. If you want to use Thread Seal Tape over Liquid Thread Sealant, by all means, use what you are most familiar with. However, you **must** carefully read and use the following instructions.

Important Notes:

- Thread Seal Tape **must** wrap **Clockwise** around the threads for it to work properly. Some customers incorrectly wrap it backward, resulting in the Tape *unwinding* as the Fitting is being tightened.
- Use only 2-3 turns of Thread Seal Tape. **Never allow Thread Seal Tape to overlap the end of the NPT Fitting threads**, the overlapping Tape will separate during tightening and enter the Hydraulic System and contaminate the Power Unit components and the Reservoir, resulting in equipment malfunction.

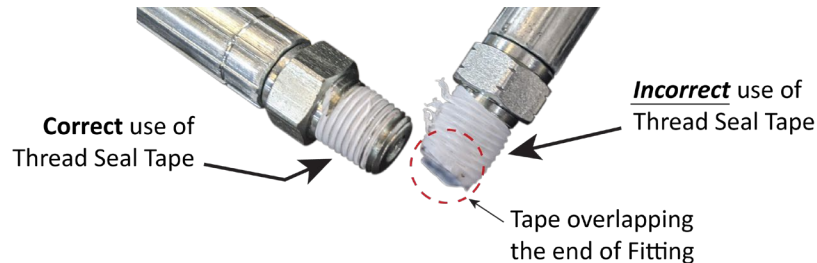

- As a general rule, Fittings with tapered threads should **not** be assembled to a specific torque, as the amount of torque varies with thread quality, Port and Fitting materials, sealant used, and other factors.
- When installing the QuickJack Hose Fittings, hand-tighten the Fittings together, then 2-3 turns after using a Wrench. Once done, **make sure to check all Hydraulic Hoses and Fitting connections before raising a Vehicle**.

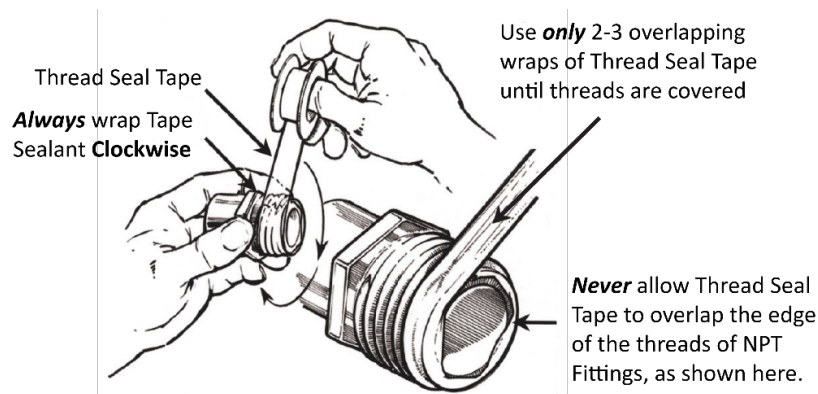

Preparing the Short Hydraulic Hoses

To prepare the Short Hydraulic Hoses, you will need from Box 3:

- **Two Short Hydraulic Hoses** (5570233).
- **Two Male Quick-Connect Fittings** (5550032).

The following graphic shows the connections to make to the Short Hydraulic Hoses.

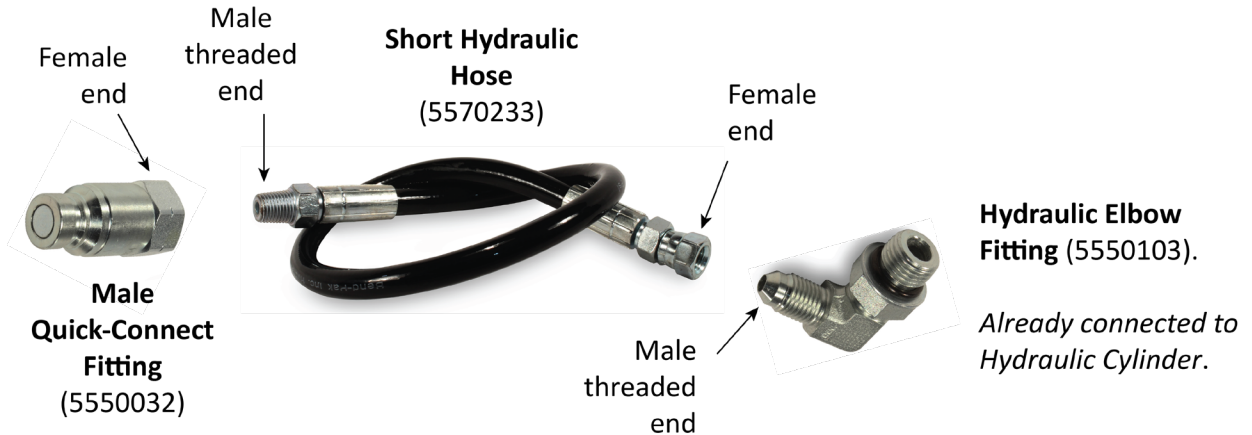

To set up and connect the Short Hydraulic Hoses:

1. Locate both Short Hydraulic Hoses and remove their protective caps.
2. Prepare the threaded fitting on the male end of each Short Hydraulic Hose with Thread Sealant.
3. Attach a Male Quick-Connect Fitting to the male threaded end of the Short Hydraulic Hose; make 2-3 full turns using a wrench to securely tighten in place.
4. Connect the other end of the Short Hydraulic Hose to the male connector on the Hydraulic Elbow Fitting on the Hydraulic Cylinder; make 2-3 full turns using a wrench to securely tighten in place.
5. Route both Short Hydraulic Hoses **under** the Frame ends; **keep them clear of pinch points!**

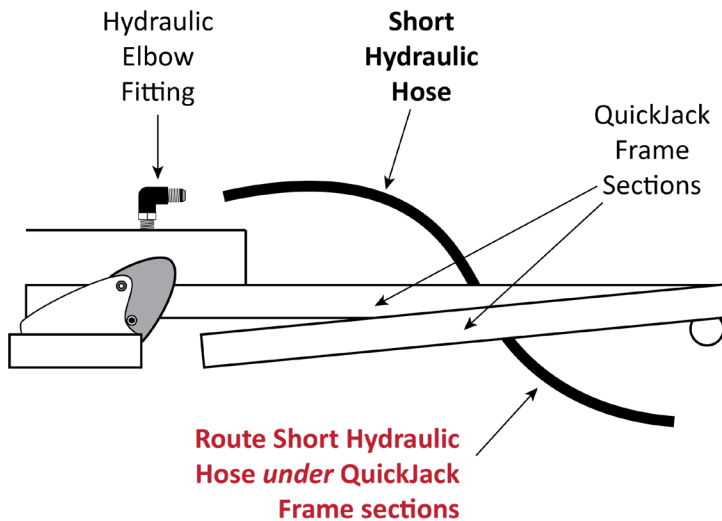

CAUTION

If you mistakenly route a Short Hydraulic Hose over the QuickJack Frame, the QuickJack will not work correctly and you could damage the hose and/or cause the Vehicle on the QuickJack to become unstable.

About Quick-Connect Fittings

Quick-Connect Fittings let you quickly connect and disconnect the QuickJack's Hydraulic Hoses.

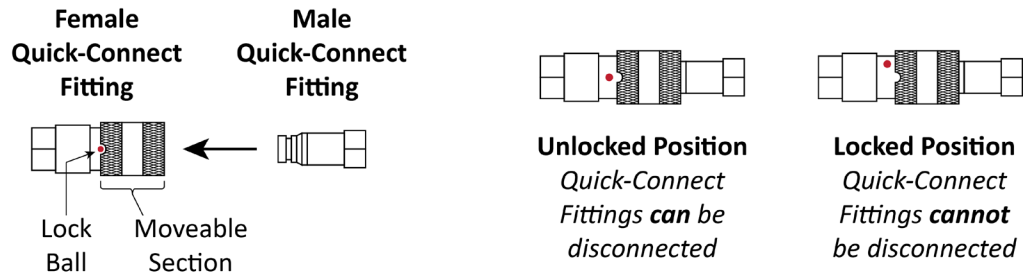

To lock a connection: Push the Male Quick-Connect Fitting into the Female Quick-Connect Fitting, then turn the Moveable Section so that the Lock Ball is not opposite the Notch.

To unlock and disconnect a connection: Turn the Moveable Section so the Lock Ball is opposite the Notch, then pull back on the Moveable Section and pull out the Male Quick-Connect Fitting.

Preparing and Connecting the Long Hydraulic Hoses

To connect the Long Hydraulic Hoses, you will need from Box 3:

- **Two Long Hydraulic Hoses** (5570216).
- **Four Female Quick-Connect Fittings** (5550031).

The following graphic shows the connections to make to the Long Hydraulic Hoses.



To prepare and connect the Long Hydraulic Hoses:

1. Locate both Long Hydraulic Hoses and remove their protective caps.
2. Prepare the Threaded ends with the supplied Thread Sealant.
3. Connect the Female Quick-Connect Fittings to the male threaded connectors on both ends of both Long Hydraulic Hoses.

To tighten, use one wrench to hold the Male connector in place and a second wrench on the Female Quick-Connect Fitting to tighten it; make 2-3 full turns using a wrench to securely tighten in place.

4. Connect one end of the Long Hydraulic Hose to the Short Hydraulic Hose; the other end of the Long Hydraulic Hose connects to the Power Unit; do the same for the other Long Hydraulic Hose and Short Hydraulic Hose.

Pressurizing the Air Cylinders

The Air Cylinders need to be pressurized before you can use your QuickJack.

Note: The Valve Stems on the Air Cylinders are installed at the factory.

⚠ CAUTION Make sure the QuickJack Frames are **fully lowered** when you pressurize the Air Cylinders.

To pressurize the Air Cylinders:

1. Use a valve tool to release a short hiss of air to check the air inflation valve for proper operation and to drain any accumulated oil.

Holding the valve open releases the air currently in the Air Cylinder.

2. Using a pump or air compressor, inflate the Air Cylinder to from 40 to 50 psi / 2.75 to 3.4 BAR; **do not exceed 50 psi / 3.4 BAR**.

The **JackPak accessory** can also be used to pressurize the Air Cylinders.



3. When the pressure is between 40 and 50 psi / 2.75 to 3.4 BAR, remove the pump or air compressor.

⚠ WARNING Do **not** exceed 50 psi / 3.4 BAR with the QuickJack Frames in the fully lowered position, as there is a chance of explosion. Make sure to remove power and bleed off air pressure before servicing.

4. Repeat Steps 1 through 3 for the other Air Cylinder.

Find a Location for the Power Unit

Based on the combined length of the included Hydraulic Hoses, the Power Unit can be about **10 to 12 feet (3-3.5m) away** from your QuickJack Frames and out of the way of the Vehicles you will be working on.

Note: Some Power Units come with a carrier and handle, some with just a handle. They work the same.

CAUTION Do not drive vehicles **on** the Hydraulic Hoses; this damages the hoses, making it more likely that they will leak.

WARNING **Risk of explosion.** The QuickJack Power Unit has arcing or sparking parts that should not be exposed to flammable vapors. The Power Unit should be located at least 460 mm (18 inches) above the floor.

Installing the Hydraulic Fittings on the Power Unit

Before you can connect your Power Unit to the Long Hydraulic Hose, you first need to install Quick-Connect Fittings to the Hydraulic Ports on the Power Unit.



Tip

QuickJack recommends installing the bottom Power Unit Quick-Connect Fitting first, then the top one. It is difficult to access the bottom Fitting if you install the top Fitting first.

You usually only have to install these Fittings once. To move your QuickJack later, just disconnect the Power Unit from the Long Hydraulic Hoses using the Quick-Connect Fittings.

To connect Power Unit Quick-Connect Fittings to Power Unit Hydraulic Ports:

1. On the Power Unit, remove the plastic Shipping Plugs from the two Hydraulic Ports on the front.
2. Take a Quick-Connect Fitting (5550413) from the Parts Bag, insert the ORB end into one of the two Hydraulic Ports on the front of the Power Unit; do the same for the second Quick-Connect Fitting on the Power Unit.

NOTICE **The ORB end can be hand-tightened in place.** Use a wrench for an additional half of a turn to ensure snugness, if needed.

Do not use Thread Sealant on the O-ring threads.

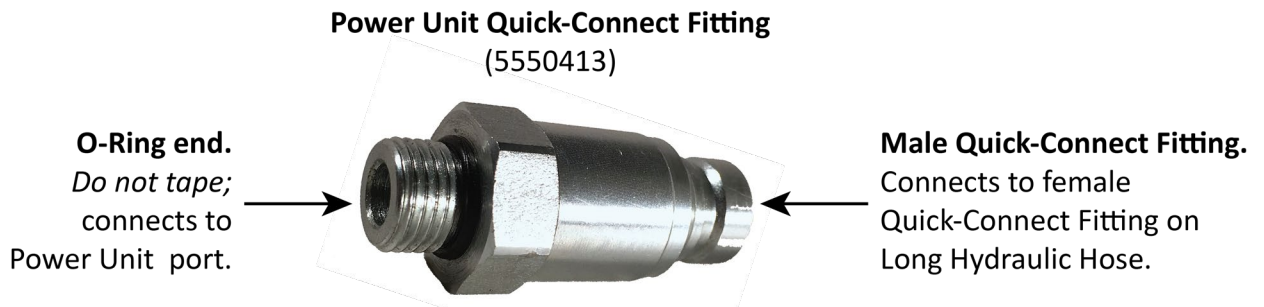

Connect the Power Unit to a Power Source

Your Power Unit must also be located near an appropriate power source. Refer to the manufacturer's data tag on the QuickJack to confirm the Power Unit's Voltage/Current requirements on your specific unit before connecting to electrical power.

Power Sources for Model Series 5000, 6000 and 7000 Power Units

Connect your QuickJack to an appropriate power source.

110 VAC Power Unit 60 Hz. 1 Ph. at 10 Amps min.

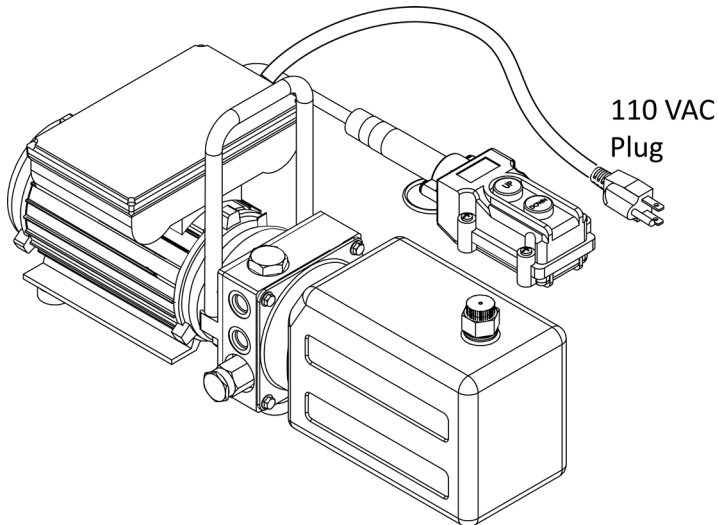

208-240 VAC Power Unit 50/60 Hz. 1 Ph. At 5 Amps min.

208 - 240 VAC Power Units include an IEC 60320 C14 Power Inlet Connector.

Due to the wide variety of 220 VAC plug configurations a mating Power Cord is not included with the QuickJack

You must purchase a cord with a mating plug/receptacle configured to operate in your locality. A Type D plug is illustrated below as an example. **The interconnecting cord must be rated for 250 VAC at 5 Amps minimum.**

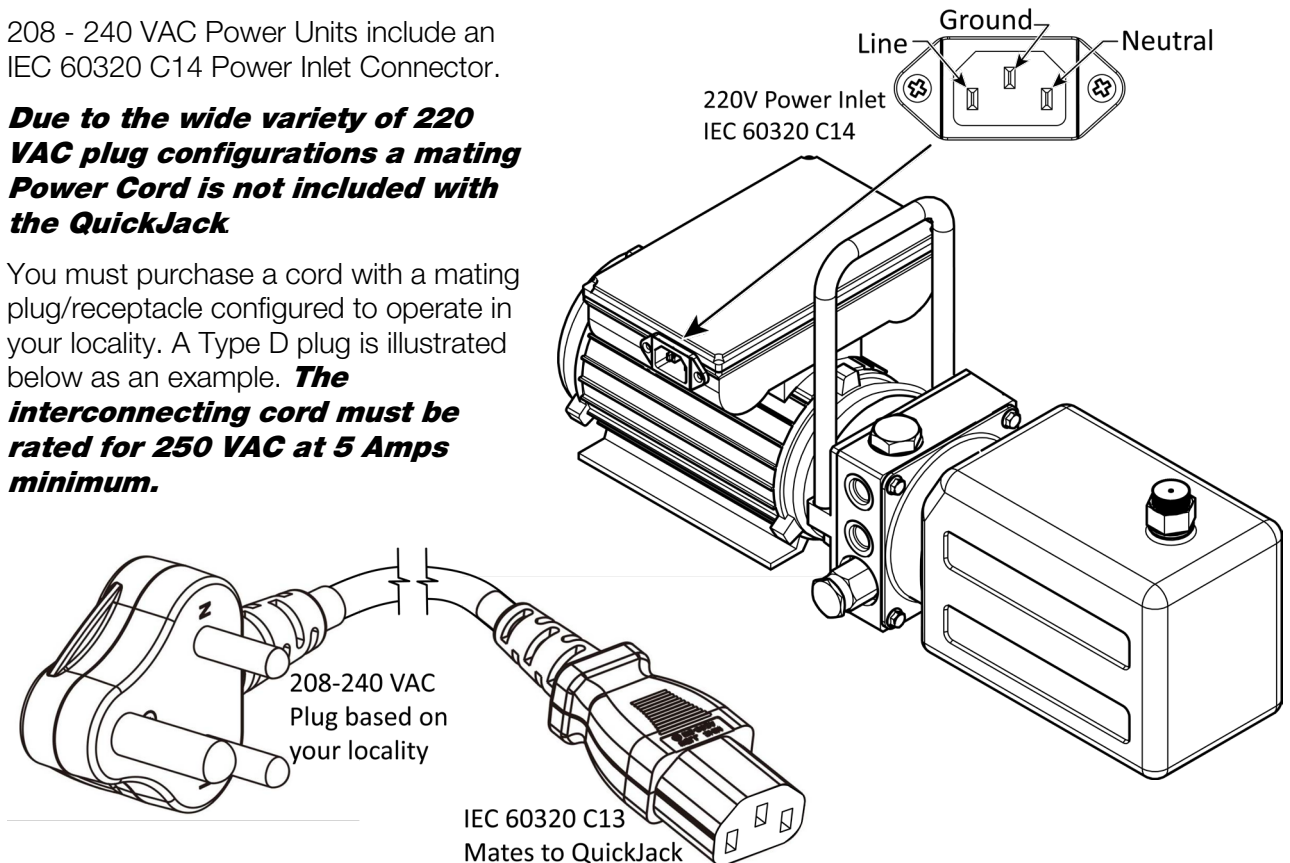

Filling the Hydraulic Fluid Reservoir on the Power Unit

The Hydraulic Fluid Reservoir must be filled with Hydraulic Fluid or Automatic Transmission Fluid **before** you begin operation of the QuickJack.

When you receive it, the Fluid Reservoir is empty. The Power Unit will not work correctly until it is filled with approved fluids.

The fluid level should be approximately .5 inch (12 mm) below the Fill Hole when the QuickJack is fully lowered.

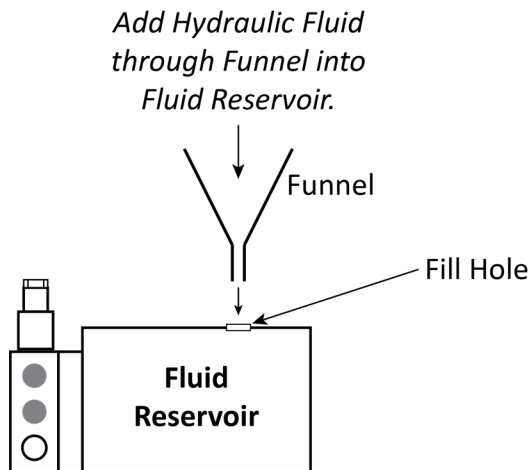

CAUTION If you use the QuickJack **without** fluid in the reservoir, you could damage the Power Unit.

WARNING Hydraulic Fluid under pressure is dangerous. You must wear OSHA-approved (publication 3151) Personal Protective Equipment **at all times** when handling hydraulic components: eye protection and leather gloves are mandatory.

Approved fluids are any general purpose ISO-32, ISO-46, or ISO-68 Hydraulic Fluid, approved Automatic Transmission Fluids such as Dexron III, Dexron VI, Mercon V, Mercon LV, or any synthetic multi-vehicle Automatic Transmission Fluid.

Note: The fluid level drops some after you start using the QuickJack; this is because some fluid stays in the Hydraulic Hoses. If you notice that the fluid level has dropped more than a little, you should fill it back up to half an inch below the Fill Hole (with the Frames on the ground).

Important: Do not completely fill the Fluid Reservoir while there is fluid in the hoses. If you do, the Reservoir could overflow when the fluid in the hoses returns (when you lower the QuickJack Frames).

QuickJack recommends having a couple of rags nearby in case any fluid leaks.

Check the Breather Valve

If your Power Unit has a Reservoir Cap with a Breather Valve, you need to loosen the Breather Valve **before** using the Power Unit. It ships tightened, so that no contaminants will get inside.

If your Power Unit has a Self-Venting Reservoir Cap (see drawing below), you do **not** need to loosen it.

To check the Breather Valve:

1. Determine what Breather Valve is on your Power Unit:

- **Reservoir Cap, with Breather Valve.** The Breather Valve comes from the factory tightened. You must loosen it before you start using the Power Unit.

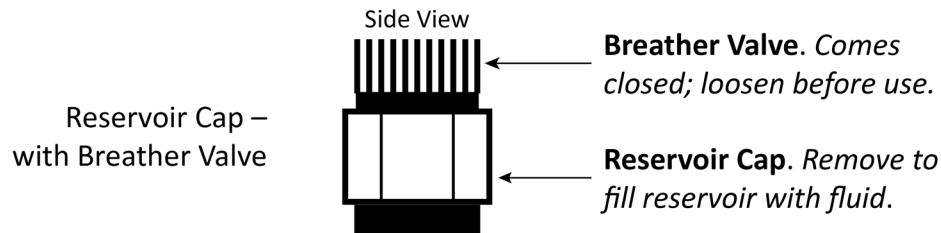

- **Reservoir Cap, Self-Venting.** There's nothing to loosen; proceed to the next section.

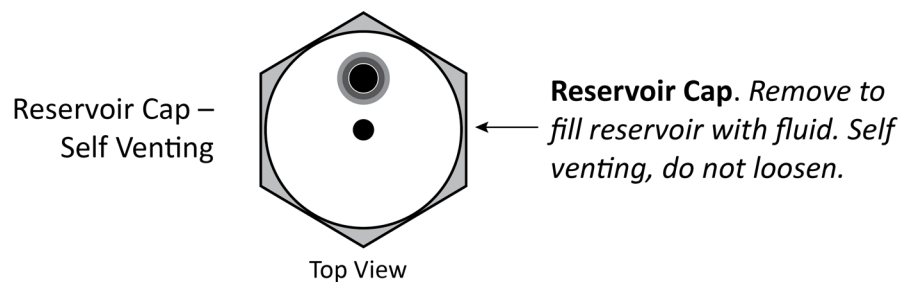

⚠ CAUTION If you have a Reservoir Cap with a Breather Valve, you **must** loosen it about half a turn counterclockwise before using the Power Unit. If you do not, the excess pressure could damage the pump or cause the Fluid Reservoir to overflow.

2. To loosen a Breather Valve, turn it from one quarter to one half turn **counterclockwise**.
3. If you are going to move the Power Unit to a different location, tighten the Breather Valve before you move it.

This helps prevent fluid from leaking and contaminants from getting into the Fluid Reservoir during transport.

Make sure to loosen the Breather Valve again **before** using the Power Unit at the new location.

Bleeding the Hydraulic Cylinders

Bleeding the Hydraulic Cylinders removes air from the Hydraulic System.

If you have air in the Hydraulic System, you can experience shaking, jerking, one frame rising faster than the other, and so on during raising and lowering. This does not damage the QuickJack or the Hydraulic Cylinder, but it is not the normal *smooth* experience you should be getting.

To bleed the Hydraulic Cylinders, you are going to need:

- multiple **rags** to wipe up fluid
- a **3/16" hex key** (also called an Allen® key) to loosen and tighten the Bleeder Screws
- **six of the Lift Blocks** that came with the QuickJack: four Tall and two Medium

Do **not** put a Vehicle on the QuickJack Frames when bleeding the Hydraulic Cylinders.

Important In general, you should **never** raise your QuickJack Frames without weight. However, for bleeding the Hydraulic Cylinders, we recommend **not** adding weight to the QuickJack Frames. **Do not raise beyond the First Locking Position without weight!**

To bleed the QuickJack's Hydraulic Cylinders:

1. Lay the two QuickJack Frames next to each other on the ground.

⚠ CAUTION Keep hands clear of pinch points at all times; you could be injured.

2. Stack two of the Tall Lift Blocks on each other, and then put one of the Medium Lift Blocks on top of them. Do this twice, so you have 2 sets of three stacked Lift Blocks.
3. Raise the Wheels end of the QuickJack Frames, one Frame at a time, and put one set of stacked Lift Blocks under the Flat Plate that is under the Bleeder Screw.

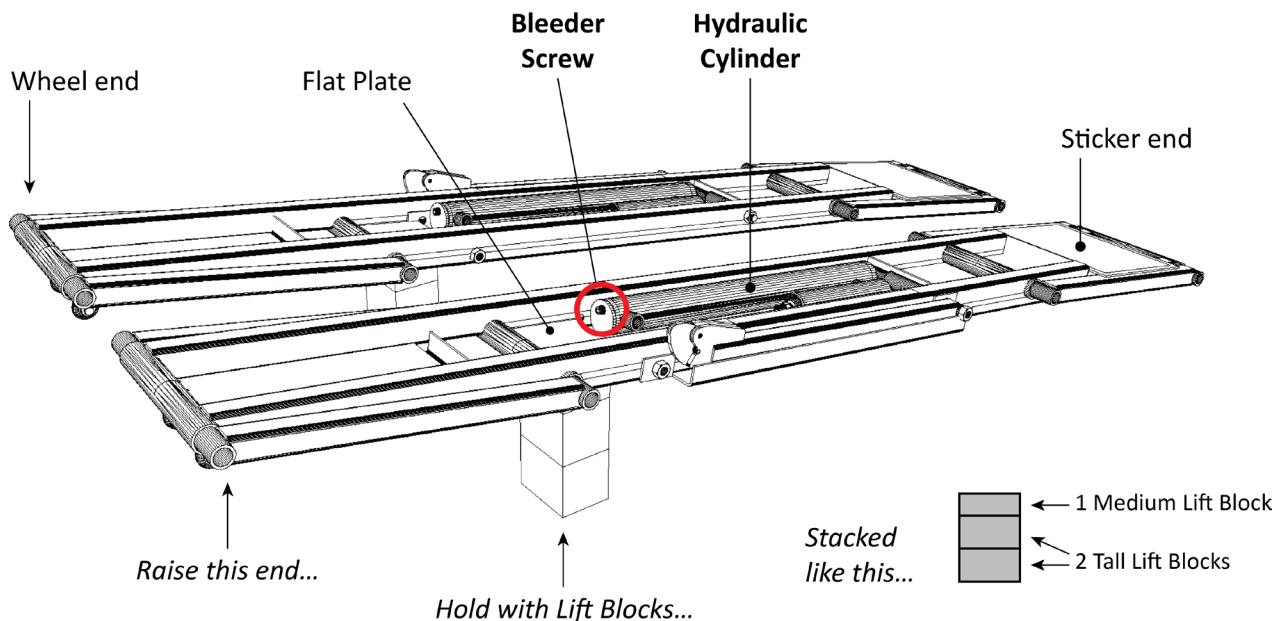

⚠ CAUTION Do **not** put the stacked Lift Blocks under the Wheel end of the Frame. The Wheel end of the Frame moves when the QuickJack is being raised or lowered, which could lead to the stacked Lift Blocks falling over.

4. Gently rock each QuickJack Frame to make sure it is stable on the stacked Lift Blocks.

-
5. If a Frame is **not** stable, adjust the Lift Blocks and/or the QuickJack Frame until it is stable.

Do not proceed until both QuickJack Frames are stable on the stacked Lift Blocks.

6. Using the Pendant Control, raise and then lower both Frames about 8 in / 203 mm or so off the ground (do not pass the First Locking Position) **three times**.

Note: Without the weight of a Vehicle on them, the QuickJack Frames may lower unevenly and slower than normal.

Raising and lowering the Frames moves Hydraulic Fluid into the Hydraulic System and pushes air towards the Bleeder Screws.

7. Put a clean rag under the Bleeder Screw on the Hydraulic Cylinder you are going to bleed first.
There is definitely going to be Hydraulic Fluid coming out, so it is better to be ready for it.
8. Loosen the Bleeder Screw using the hex key.
9. When you hear air escaping, stop loosening the Bleeder Screw—air and some Hydraulic Fluid come out.

 **WARNING** You must wear OSHA-approved (publication 3151) Personal Protective Equipment **at all times** when handling hydraulic components: eye protection and leather gloves are mandatory.

10. When no more **air** is coming out, tighten the Bleeder Screw and wipe up the Hydraulic Fluid.

11. Put another rag under the Bleeder Screw.

12. Press **Up** on the Pendant Control for a couple of seconds, then stop.

This helps to move any remaining air towards the Bleeder Screw.

13. Open the Bleeder Screw a small amount.

14. Press **Up** on the Pendant Control for a couple of seconds *only*, then stop.

A combination of air and Hydraulic Fluid comes out.

15. Tighten the Bleeder Screw.

The Bleeder Screw must be tightened before you press **Down** on the Pendant Control. If it is not tightened, air will be pulled **in** as the QuickJack Frames lower.

16. Press **Down** on the Pendant Control; return the QuickJack Frames to flat.

Note: Without the weight of a Vehicle on them, the QuickJack Frames may lower unevenly and slower than normal.

17. Repeat Steps 13 through 16 until no more air comes out.

18. Clean up any remaining Hydraulic Fluid.

19. Tighten the Bleeder Screw with the hex key: **do not overtighten**.

20. Lift one of the QuickJack Frames, remove the stacked Lift Blocks, lower the frame back down to the ground, and then repeat for the other QuickJack Frame.

Final Checklist Before Operation

Make sure these things have been done **before** using your QuickJack:

- Review the **Setup Checklist** to make sure all steps have been performed.
- Make sure the Power Unit is getting power from the power source.
- Check the Hydraulic Fluid Reservoir; it must be full of approved Hydraulic Fluid or automatic transmission fluid. **You can harm the motor by running it without enough fluid.**
- Check the Hydraulic System for leaks. Verify all Hydraulic Hose connections, Hydraulic Fittings, and Auxiliary Port Plugs on the Frames and Power Unit are secure.
- Make sure both Lock Bars are moving freely and in their tracks; make sure there are no obstructions in the tracks.

Test the QuickJack

Make a visual check of all components to make sure they are in good working order **prior** to raising a Vehicle; do this **every time** you use your QuickJack. Check the Quick-Connect Fittings for wear, damage, or leakage; do not raise a Vehicle if the Quick-Connect Fittings are damaged or worn—you must replace them.

Important: **Only raise the QuickJack Frames with a Vehicle on them.** The QuickJack Frames are engineered and designed to support the weight of a Vehicle; they can occasionally get stuck at full height if there is no Vehicle on them.

 **WARNING** **When raising or lowering a QuickJack, pay attention!** A common safety issue is lack of Operator attention; for example, **do not** be looking at a smartphone while raising or lowering the QuickJack. It is your responsibility to pay attention; if you do not, you could damage the QuickJack or the Vehicle on it and/or injure people near it.

See **Raising the QuickJack Frames** for detailed information about raising the QuickJack Frames.

To test your QuickJack:

1. Place the QuickJack Frames in the desired location with **both Lock Bars on the outside**.
2. Check both Lock Bars and all of the Hydraulic Hoses.

The Lock Bars must be able to move freely along the bottom of their Channels; they must not stay up in the air when you raise the Frames (if they do, the most likely problem is that the Lock Bar Bolt is over-tightened). The Hydraulic Hoses must all be connected.

3. Make sure the Power Unit has been set up correctly and is connected to a power source.

The fluid level should be approximately .5 inch (12 mm) below the fill hole.

Important: If you do not put enough Hydraulic Fluid in the reservoir, the QuickJack may start to rise but will slow and then stop when the reservoir is out of fluid. To fix this, lower the QuickJack Frames back down to the ground and then add additional fluid to the reservoir. Fill it to approximately .5 inch (12 mm) below the Fill Hole.

4. Check the pressure in the Air Cylinders; they should register from 40 to 50 psi (2.75 to 3.4 BAR).
Do **not** exceed 50 psi / 3.4 BAR.
5. Put a Vehicle into place. **Do not raise your QuickJack without the weight of a Vehicle.**
6. Position the Lift Blocks in the Receiver Trays for the Vehicle you are going to raise.

Be sure to use the factory-recommended Lifting Points for the Vehicle.

7. Press **Up** on the Pendant Control for a couple of seconds.

After a few seconds, the QuickJack Frames will start moving up. As this is the first use, it takes a couple of seconds for the Hydraulic Hoses to fill with fluid.

If the QuickJack Frames do not move, make sure the Power Unit is connected to an appropriate power source, make sure the Hydraulic Hoses are connected to the Power Unit, and make sure there is sufficient Hydraulic Fluid in the reservoir. If you find any of these issues, fix them and then try again. If the Frames still do not move, refer to **Troubleshooting**.

8. Just **before** the Frames make contact with the Lifting Points on the Vehicle, release **Up**.
9. Check the locations where the Lift Blocks will hit the Lifting Points. If necessary, adjust the Lift Blocks so they are properly positioned.
10. Press **Up** to raise the Frames to just past the First Locking Position, then press **Down** for 3 to 4 seconds.

⚠ WARNING If one Frame goes up faster than the other with the weight of a Vehicle on it, this is a safety hazard. Release **Up** immediately and then press **Down** to lower the Vehicle back down to the ground. Wait a minute and then try again. If the issue continues, refer to **Troubleshooting**.

The Lock Bar will lock at the First Locking Position and the Frames will stop moving.

11. With the QuickJack engaged on the First Locking Position, check all Hydraulic Hose connections for leaks. If you find any, tighten the leaking connection and wipe up the fluid.

If the motor gets hot or sounds irregular, check the Power Unit and all electrical connections.

12. Carefully rock the Vehicle to test its stability.

If the Vehicle seems stable, the QuickJack is ready for normal operation.

If the Vehicle does **not** seem stable, lower it back to the ground and check the positioning of the Lift Blocks in the Receiver Trays.

13. If everything appears to be working normally, lower the QuickJack Frames back down to the ground. To do this: press **Up** for a second or two so that the Lock Bars go past the Lock Blocks, then press **Down** until the Lock Bars lower past the Lock Blocks.

When the Frames get to the ground, hold **Down** for another ~5 seconds so that the Hydraulic Fluid returns to the reservoir.

If there are issues you cannot resolve, stop using the QuickJack, then refer to **Troubleshooting**, or call QuickJack at **(888) 262-3880** or **(805) 933-9970**.

Leave the Manual with the Owner/Operator

Make sure to leave the *Setup and Operation Manual* with the owner/operator so that it is available to everyone who is going to use the QuickJack.



Operation

This section describes how to operate your QuickJack. This manual must be delivered to the owner/user/employer and be kept near the QuickJack.

QuickJack recommends using *Vehicle Lifting Points for Frame-Engaging Lifts* for proper positioning of Vehicles on your QuickJack. It shows the factory-recommended Lifting Points for a wide variety of Vehicles. It is available on the [ALI website](#).

QuickJack also recommends SAE Standard J2184, *Vehicle Lift Points for Service Garage Lifting*, as a resource to assist you in the proper positioning of a Vehicle for raising.

⚠ WARNING Make sure to properly position each Vehicle on its Lifting Points. Improper positioning of a Vehicle could lead to it being unstable and potentially falling off the QuickJack. This could damage the Vehicle, damage the QuickJack, and potentially injure anyone nearby. Do not use QuickJack on slippery floors.

Safety

Before you raise or lower a Vehicle using your QuickJack:

- **Check the QuickJack.** Check the QuickJack Frames for any missing, heavily worn, or damaged parts. Make sure the Lift Blocks are in their Receiver Trays. Do not operate the QuickJack if you find any issues; instead, stop using it, then visit quickjack.com/support, email support@quickjack.com, or call **(888) 262-3880**.
- **Check the area.** Check the area around the QuickJack for obstructions; anything that might impact the raising or lowering of the Vehicle. Do not forget to check **above** the QuickJack. If you find an obstruction, move it out of the way. Do not allow unauthorized people, children, or animals near the QuickJack while it is being used.
- **Check the operators.** Make sure everyone who is going to operate the QuickJack has been trained in its use, has read the labels on the unit, is not under the influence of drugs or alcohol, and has read the manual.

⚠ WARNING ***When raising or lowering a QuickJack, the Operator must pay attention!*** A common safety issue is lack of attention; for example, Operators must **not** be looking at a smartphone.

- **Check for safety.** Make sure everyone who is going to be walking near the QuickJack is aware of its presence and takes appropriate safety measures. ***When raising a Vehicle, always leave the QuickJack engaged on a locking position.*** When lowering the QuickJack, do not leave it until it is on the ground.

⚠ WARNING You must **always** use auxiliary safety stands under the Vehicle while elevated on both QuickJack Frames.

⚠ WARNING ***Risk of explosion.*** The QuickJack Power Unit has arcing or sparking parts that should not be exposed to flammable vapors. The Power Unit should be located at least 460 mm (18 inches) above the floor.

- **Check the Vehicle.** Never exceed the QuickJack's weight rating. Do not allow people inside a Vehicle you are raising. Make sure the Vehicle is not overbalanced on either end. You must use the factory-recommended Lifting Points for the Vehicle. Never raise just one side, one corner, or one end of a Vehicle.

About Lift Blocks

When raising a Vehicle with your QuickJack, the Vehicle should not touch the QuickJack Frames. Instead, they should touch the Lift Blocks that are sitting in the QuickJack's Receiver Trays.

There are three types of Lift Blocks available:

- **Medium/Tall.** Four Medium and four Tall Lift Blocks are *included with each QuickJack*. You can stack one Medium on one Tall, but no more than that; make sure they are centered under the Lifting Points.
- **Pinch Weld.** Ideal for raising Vehicles by their pinch welds. *Separate purchase.*
- **SUV and Light Truck Adapter.** Each set includes four round Contact Pads, four Extenders, and four Bases. Perfect for Vehicles with high ground clearance or non-standard Lifting Points. *Separate purchase.*

CAUTION

Do not raise a Vehicle on the QuickJack Frames; always use Lift Blocks, Pinch-Weld Blocks, or SUV and Light Truck Adapters in the Receiver Trays. Raising a Vehicle on the Frames could damage the Vehicle and/or damage the QuickJack.

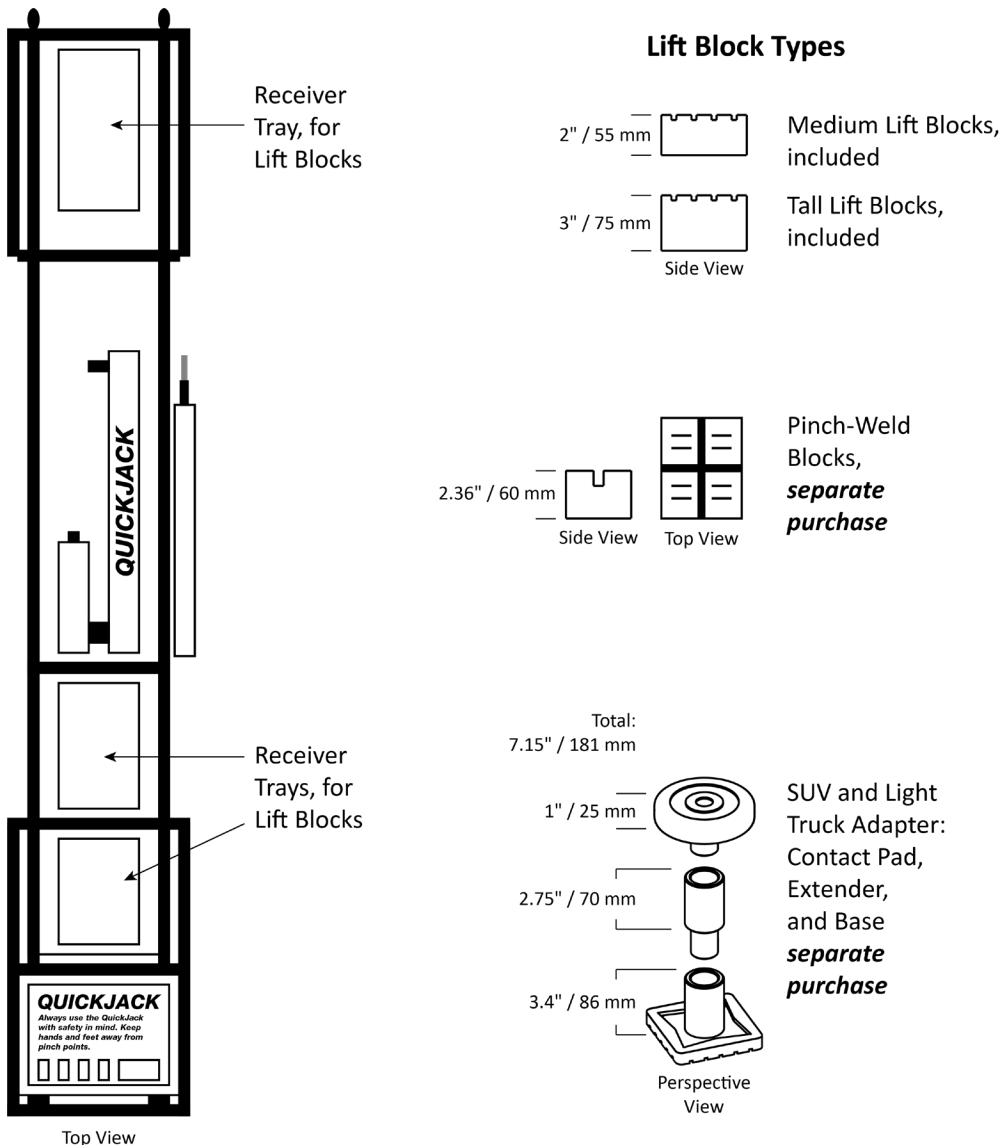

Drawing not necessarily to scale. Not all components shown.

Special QuickJack Warnings

There are two special cases with QuickJack of which you need to be aware:

- **Do not raise QuickJack Frames without a Vehicle on them.** QuickJack Frames are designed and engineered to be used with the weight of a Vehicle on them. You should only raise the QuickJack Frames with the weight of a Vehicle on them, ***even the very first time you use them.*** The only exception to this rule is if you are bleeding the Hydraulic Cylinders.

QuickJack Frames can occasionally get stuck in a raised position if you raise them without the weight of a Vehicle. There is nothing wrong with them if this happens, and the issue can be quickly and easily fixed, it's just that they are designed and engineered to work with the weight of a Vehicle. ***Only raise your QuickJack Frames with a Vehicle on them.***

- **Do not try to raise a load at no net rise.** Your QuickJack requires some space between the ground and your Vehicle to build up enough pressure to raise a load. It cannot raise a full load from a completely flat starting position, as shown below.

This is not a problem in normal operation, as the Vehicles you want to raise are being held well above the ground by their tires. The problem happens if you lower the QuickJack to a completely flat position when the Vehicle's tires are removed.



- ⚠ WARNING** This image shows the QuickJack Frames at a completely flat position holding a Vehicle with no tires. **Do not do this**; the QuickJack will not be able to raise the weight of the Vehicle under these circumstances. If this happens to you, refer to **Troubleshooting**, visit quickjack.com/support, or send email to support@quickjack.com for instructions.

Positioning the Lift Blocks and Frames

⚠ WARNING Always position the two QuickJack Frames as close to parallel as the Lifting Points of the Vehicle allow; load stability can be compromised if they are too far off from parallel.

There are two methods for positioning your QuickJack Frames:

- **Outside in:** Drive the Vehicle to the desired location, position the QuickJack Frames **outside** the Vehicle on different sides and between the wheels. If the distance between the wheels is not long enough to accommodate the length of the QuickJack Frames, turn the Frames and push one end under the Vehicle first, then the other end. Quick Frame Handles are typically not required. Make sure **not** to drive on the QuickJack's Hydraulic Hoses. Slide each Frame to the desired location under the Vehicle when ready. **Make sure each Lock Bar is on the outside.**
- **Inside out:** Position the QuickJack Frames next to each other, drive the Vehicle above the Frames, then use your Quick Frame Handles to pull each Frame out to the desired location under the Vehicle based on the factory-recommended Lifting Points. Make sure **not** to drive on the QuickJack's Hydraulic Hoses. **Make sure each Lock Bar is on the outside.**

⚠ CAUTION Before positioning QuickJack Frames, make sure they are both fully lowered and that your working area is clear of obstructions. Also, make sure the Vehicle you will be raising is neither rear or front heavy, which throws off its balance.

To position the QuickJack Frames:

1. Determine the desired method for positioning your QuickJack Frames.
2. Position the Lift Blocks, Pinch-Weld Blocks, or SUV and Light Truck Adapters in the Receiver Trays.

Note: You can stack one Medium and one Tall Lift Block together, but not more than that.

⚠ CAUTION Do not raise any load on the Frames alone; **always** use Lift Blocks, Pinch-Weld Blocks, or the SUV and Light Truck Adapters in the Receiver Trays.

3. Move the QuickJack Frames to the appropriate locations, based on positioning method.
4. If you are using the Inside out method, drive the Vehicle above the Frames.
5. Move the QuickJack Frames to the correct locations under the Vehicle based on the factory-recommended Lifting Points.

⚠ WARNING If you do not know the factory-recommended Lifting Points for the Vehicle you are raising, consult *Vehicle Lifting Points for Frame-Engaging Lifts*, and SAE Standard J2184, *Vehicle Lift Points for Service Garage Lifting*, as a resource to assist you in the proper positioning of a Vehicle for raising (these documents are available on the [ALI website](#)). If the Vehicle has an additional or uniquely positioned payload, have a qualified person calculate the Vehicle center of gravity or have the Vehicle center of gravity determined at a Vehicle scale.

6. Adjust the Lift Blocks in the Receiver Trays so that they are roughly underneath the factory-recommended Lifting Points for the Vehicle you are raising.

Important: Make sure to account for radial shift when raising larger Vehicles on QuickJack.

The QuickJack Frames and Lift Blocks are now positioned correctly for raising a Vehicle.

Raising the QuickJack Frames

QuickJack Frames have two locking positions. When you raise the QuickJack Frames, always engage both Frames on a Locking position of the same height or lower them back down to the ground.

⚠ WARNING Do not raise a Vehicle unless the QuickJack Frames are properly positioned under the Vehicle, the Frames are as close to parallel as possible, all personnel are a sufficient distance away from the Vehicle, both Lock Bars are on the outside, there is open space on all sides and above the Vehicle, and the operator is paying attention (the operator must maintain visual contact with the Vehicle and the surrounding area while raising or lowering the QuickJack Frames).

To raise a Vehicle:

1. Position the Lift Blocks, Pinch-Weld Blocks, or SUV and Light Truck Adapters in the Receiver Trays.

Note: You can stack one Medium Lift Block on one Tall Lift Block, but ***not more than that***. Do not stack Lift Blocks on Pinch-Weld Blocks or SUV and Light Truck Adapters.

⚠ CAUTION Do not raise any load on the Frames alone; ***always*** use Lift Blocks, Pinch-Weld Blocks, or the SUV and Light Truck Adapters in the Receiver Trays.

2. Move the QuickJack Frames to the appropriate locations, based on positioning method.
3. Drive the Vehicle over the Frames if you are using the Inside out method.

Only raise your QuickJack with a Vehicle on it.

4. Move the QuickJack Frames to the correct locations under the Vehicle based on the factory-recommended Lifting Points.

⚠ WARNING If you do not know the factory-recommended Lifting Points for the Vehicle you are raising, consult *Vehicle Lifting Points for Frame-Engaging Lift* and SAE Standard J2184, *Vehicle Lift Points for Service Garage Lifting*, as a resource to assist you in the proper positioning of a Vehicle for raising (these documents are available on the [ALI website](#)). If the Vehicle has an additional or uniquely positioned payload, have a qualified person calculate the Vehicle center of gravity or have the Vehicle center of gravity determined at a Vehicle scale.

5. Adjust the Lift Blocks in the Receiver Trays so that they are directly underneath the factory-recommended Lifting Points for the Vehicle you are raising.
6. Check both Lock Bars; raise them up and let them drop.

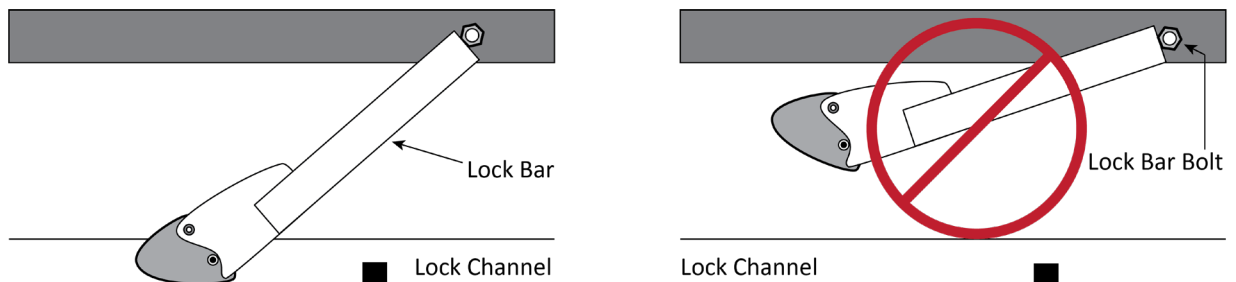

*Not necessarily to scale. Not all components shown. Left side shows Lock Bar moving freely in Lock Channel, right side shows Lock Bar stuck up in air, which **must** be corrected.*

If the Lock Bar *Bolt* is too tight, it does not allow the Lock Bar to move freely in the Lock Channel. ***This is a safety issue***; the QuickJack locks cannot be engaged unless each Lock Bar is moving freely in its Lock Channel. If the Lock Bar moves up with the Vehicle as it is raised (as shown above on the right), it cannot lock.

⚠ WARNING The Lock Bar ***must*** be moving freely in the Lock Channel. If it is not, the QuickJack cannot be put into a safe, locked position.

To fix an overtight Lock Bar Bolt, loosen the Lock Bar Bolt until the Lock Bar moves freely and stays in the Lock Channel (as shown above, on the left).

7. Walk around the Vehicle and the QuickJack Frames; make sure everything is set up correctly.
8. Press and hold **Up** on the Pendant Control.
9. Just ***before*** the Frames make contact with the Vehicle, release **Up**. The Frames stop moving.
10. Check the locations where the Lift Blocks will hit the factory-recommended Lifting Points on the Vehicle. If necessary, adjust the Lift Blocks so that they are properly positioned (you may need to lower the Vehicle some to adjust the Lift Blocks).
11. Make sure both Lock Bars are moving freely in their respective Lock Channels.
12. After confirming the Lift Blocks and Lock Bars are properly positioned, press **Up**.

The QuickJack Frames start going up and the Lift Blocks hit the Vehicle's Lifting Points.

⚠ WARNING Do not stop raising the Frames until you have passed the First Locking Position.

13. Make sure all Lift Blocks are still in contact with the factory-recommended Lifting Points.

If the Lift Blocks ***are*** in the right positions, continue with raising the QuickJack Frames.

If the Lift Blocks are ***not*** in the right positions, press **Down** on the Pendant Control and ***carefully*** return the Vehicle to the ground, then make the necessary adjustments.

14. To engage the QuickJack on a Locking Position, release **Up** and then press **Down** to lower the Frames until they lock.

The following drawing shows the Frame securely engaged on a locking position.

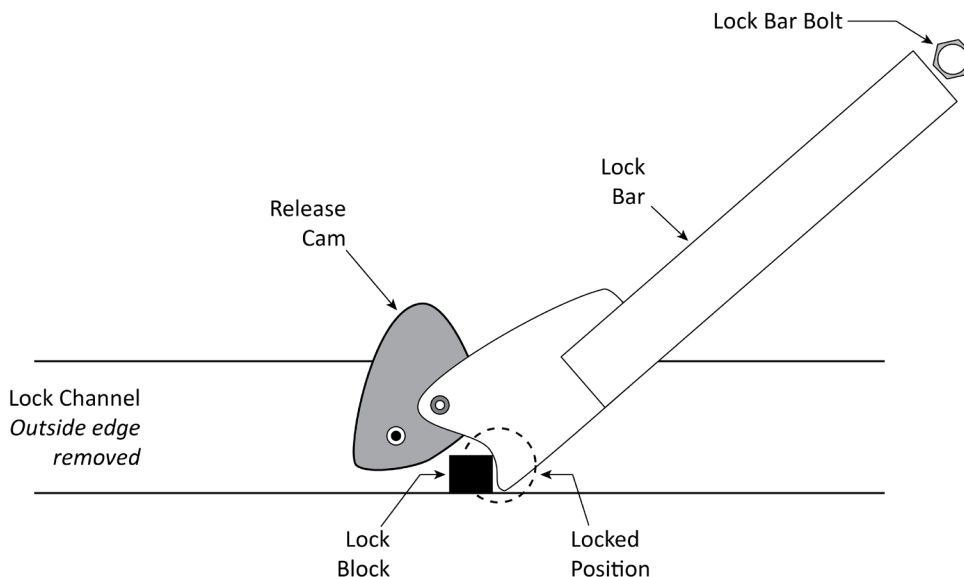

Not to scale. Not all components shown. Shows Release Cam and Lock Bar in Locked Position.

15. After 3 to 4 seconds release **Down**.

Holding the **Down** button for those 3 to 4 extra seconds helps to relieve hydraulic pressure in the system.

16. Visually check to make sure both QuickJack Frames are engaged on the same locking position.

The following graphic shows the Release Cam **not** engaged on a locking position; do **not** leave your Frames like this!

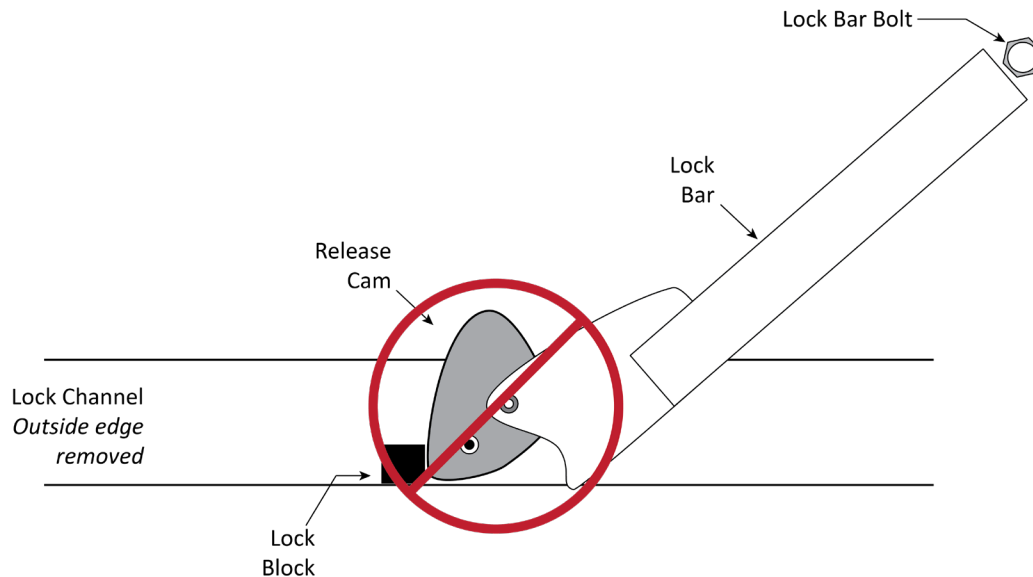

⚠ WARNING Before doing anything else (like starting work on the Vehicle or leaving the area), **visually confirm** that **both** QuickJack Frames are on the same locking positions and that all Lift Blocks are in contact with the factory-recommended Lifting Points of the Vehicle.

You can work on your Vehicle once you have visually confirmed that both Frames are engaged on the same locking position and that all Lift Blocks are in contact with the Vehicle at the factory-recommended Lifting Points.

⚠ WARNING As an added safety precaution, you must **always** use auxiliary safety stands under the Vehicle while elevated on both QuickJack Frames.

Lowering the Frames from the First Locking Position

Lowering the QuickJack's Frames from the First Locking Position is different from lowering them from the Top Locking Position, so it is described separately.

⚠ WARNING When lowering QuickJack Frames, make sure the Lock Bar and the Release Cam stay in their Lock Channel. If they get knocked sideways they can get stuck on the rail of the Lock Channel, which results in the QuickJack not lowering correctly.

To lower QuickJack Frames from the First Locking Position:

1. Press and hold **Up** on the Pendant Control just until the Release Cam clears the Lock Block, then release **Up**.

The Release Cam / Lock Bar moves away from the Lock Block towards the Top Locking Position.

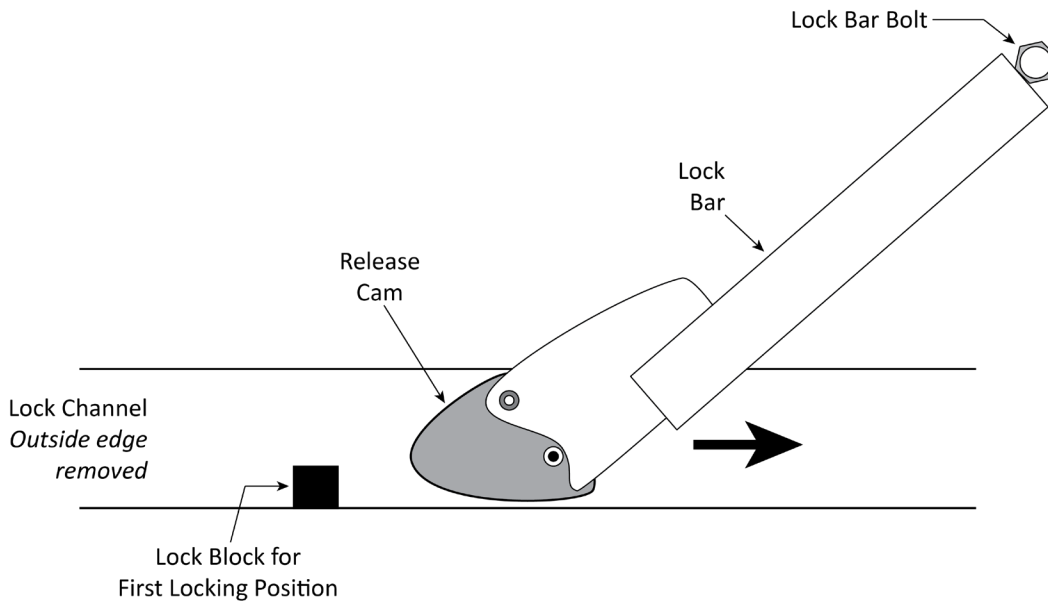

Not necessarily to scale. Not all components shown. Release Cam and the Lock Bar shown moving off of the First Locking Position towards the Top Locking Position.

2. When the Release Cam and Lock Bar are clear of the Lock Block, press and hold **Down** until both QuickJack Frames lower to the ground.

The Release Cam moves the Lock Bar over the Lock Block.

Note: If the Lock Bar locks again on the Lock Block, try again, going up a little bit further this time. What you want is for the Release Cam to be in the Down position, as shown in the drawing above.

Do not lower the Release Cam / Lock Bar if the Release Cam is in the Up position, as shown below. The Release Cam needs to be in the Down position, as shown in the drawing on the previous page.

If the Release Cam is in the Up position, *carefully* use your hand to move it to the Down position.

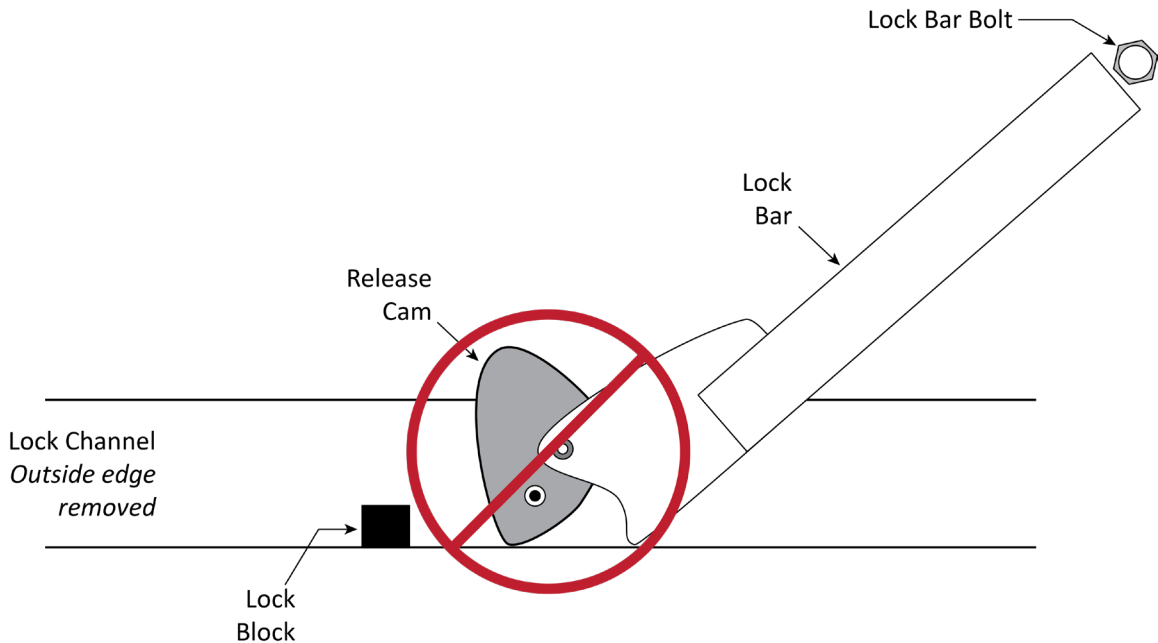

Not necessarily to scale. Not all components shown. Release Cam shown in the Up position, which must be changed to the Down position before lowering.

If one side re-engages on the Lock Block but the other does not, immediately release **Down**, press and hold **Up**, go further past the Lock Block, release **Up**, and then press and hold **Down**. If this issue continues, refer to [Troubleshooting](#).

Note: QuickJack recommends pressing **Down** for ~5 seconds *after* the Frames are on the ground; this ensures that as much Hydraulic Fluid as possible returns to the Fluid Reservoir.

3. Remove the QuickJack Frames from underneath the Vehicle; you may want to use the Quick Frame Handles.
4. Move the Vehicle, if desired.

CAUTION Do not drive on the QuickJack Frames or the Hydraulic Hoses.

Lowering the Frames from the Top Locking Position

Lowering the QuickJack's Frames from the Top Locking Position is different from lowering them from the First Locking Position, so it is described separately.

⚠ WARNING When lowering QuickJack Frames, make sure the Lock Bar and the Release Cam stay in their Lock Channel. If they get knocked sideways they can get stuck on the rail of the Lock Channel, which results in the QuickJack not lowering correctly.

To lower the QuickJack Frames from the Top Locking Position:

1. Press and hold **Up** until the Lock Bar is off the Lock Block, then release **Up**.
2. Raise the Lock Bar **on both QuickJack Frames** so that the Release Cam is on top of the Lock Block on both Frames, as shown below.

You can use your hand or your foot to raise the Lock Bar.

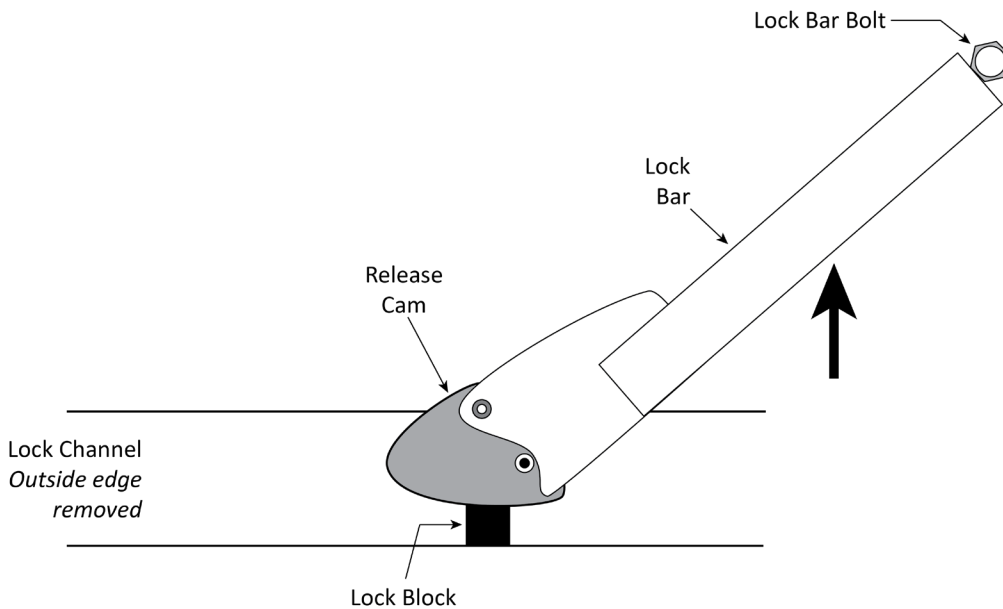

Not drawn to scale. Not all components shown. Release Cam shown on top of the Lock Block.

3. When the Release Cam is on top of the Lock Block on both Frames, press and hold **Down** until both QuickJack Frames lower to the ground.

If the Lock Bars engage on the Lock Block as the Frames go back down, start the process over again.

If one side re-engages on the Lock Block but the other does not, immediately release **Down** and then start the process again. If this issue continues, refer to [Troubleshooting](#).

Note: QuickJack recommends pressing **Down** for ~5 seconds **after** the Frames are on the ground; this ensures that as much Hydraulic Fluid as possible returns to the Fluid Reservoir.

4. Remove the QuickJack Frames from underneath the Vehicle; you may want to use the Quick Frame Handles.
5. Move the Vehicle, if desired.

⚠ CAUTION Do not drive the Vehicle on the QuickJack Frames or the Hydraulic Hoses.

Additional Operating Information

Keep the following in mind when operating your QuickJack:

- Use it only on a hard, flat surface. Your QuickJack is portable; if you move it to a new location, make sure the new location has a hard, flat surface.
- Check the weight of a Vehicle before attempting to raise it. Do not guess. Never exceed the rated load capacity of your QuickJack.
- Always use Lift Blocks. Do not raise a load on the QuickJack Frames alone.
- Lift Blocks must be used in the Receiver Trays only. The provided Lift Blocks are **not** designed for use with pinch-weld frames. If you have a Vehicle with a pinch-weld frame, QuickJack recommends ordering optional Pinch-Weld Blocks, [available on the QuickJack website](#).
- If you purchased the SUV and Light Truck Adapter Kit, the square pieces go rubber-down in the Receiver Trays on the QuickJack Frames. You can then put the round stackable adapter in the hole on the top of the square piece either by itself or combined with the extension.
- **Visually inspect your QuickJack before each use.** Do not use it if you find any damage or severe wear.
- Do not rock Vehicle while raised or remove heavy items that could cause excessive weight shift.
- The QuickJack uses a parallelogram lifting system. As the Frames rise, both the mechanical forces of the jack and pressure of the hydraulic system are reduced significantly as the parallel arms elevate through the rise motion.
- When the parallel lifting arms are elevated (the angles increase), hydraulic system pressure is reduced and mechanical load on the structure is minimized.
- Raising the QuickJack to the Top Locking Position and engaging it there is the most secure method of support.
- Stopping the QuickJack prior to reaching the first Locking Position makes it difficult for the hydraulic system to maintain equal pressure and properly support the load.
- Do not stop raising the QuickJack Frames until you have passed the First Locking Position.
- Never leave a raised load unless your QuickJack Frames are engaged on a locking position. If you do not want to engage them on a locking position, lower the raised load back down to the ground.

Hydraulic System Warnings

 **WARNING** Failure to observe these precautions can result in serious personal injury, including, in rare cases, death.

- All Hydraulic Hose connections must be correctly fastened together before using your QuickJack.
- Do not attempt to connect or disconnect Hydraulic Hoses while equipment is loaded or while the Hydraulic System is under pressure.
- Keep the Quick-Connect Fittings clean and free from debris; use every precaution to guard against dirt entering the Hydraulic System.
- Keep bare hands away from Hydraulic Fluid; always wear gloves when handling Hydraulic Cylinders and Hydraulic Hoses.
- When dealing with Hydraulic Fluid, observe the safety instructions from the manufacturer.
- Use protective equipment (safety goggles, protective gloves, suitable working clothes, safety boots, and so on) when dealing with the Hydraulic System.
- If Hydraulic Fluid comes into contact with the eyes, gets into the bloodstream, or is swallowed, seek immediate medical attention.

Maintenance

Refer to ANSI/ALI ALIS Standard (R2015) *Safety Requirements for Installation and Service of Automotive Lifts* for more information about safely servicing your QuickJack.

⚠ DANGER Before performing any maintenance to your QuickJack, make sure it is **completely** disconnected from power. If your organization has Lockout/Tagout policies, make sure to implement those procedures after connecting to the power source.

Reorder labels and worn, damaged, or broken parts from quickjack.com/replacement-parts. Only use factory-supplied parts as replacement parts.

All maintenance tasks can be performed by the owner/operator of the QuickJack.

To maintain your QuickJack:

- **Daily.** Make a visual inspection of all moving parts and check for damage or excessive wear. Replace any damaged or worn parts before equipment is put back into operation.
- **Daily.** Keep all QuickJack components clean.
- **Daily.** Make sure the Safety Locks are in good operating condition. *Do not use your QuickJack if the Safety Locks are damaged or excessively worn.*
- **Daily.** Inspect Lift Blocks for damage or excessive wear. Replace as required.
- **Weekly.** Check all hose and fitting connections to make sure they are tight.
- **Monthly.** Lubricate all hinge points and check for excessive wear.
- **Monthly.** Check Air Cylinders to make sure they have the correct amount of pressure.
- **Every other month.** Check Hydraulic Fluid levels and refill if required.
- **When noticed.** Replace all caution, warning, and safety-related labels if illegible or missing.

Lubrication Points

QuickJack recommends using white lithium grease (or equivalent) and a grease gun with an appropriate tip (a Lube-Link™, for example) for lubrication. Lubrication points are shown below.

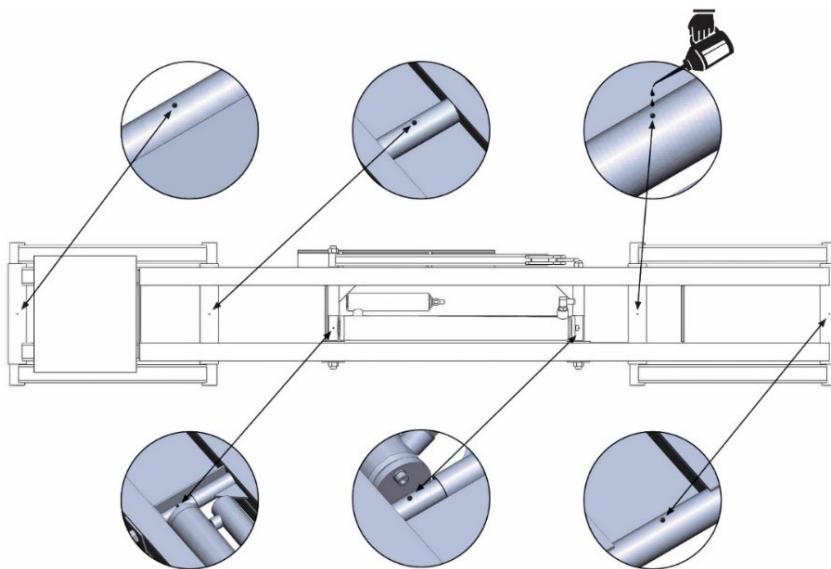

About Outdoor Operation

Your QuickJack is approved for indoor installation and use only. ***Outdoor installation is prohibited.***

Your QuickJack is portable, however, so if you end up taking it outdoors, remember to protect it from the weather (for example, from falling dirt, rain, sleet, and snow).

Here are some additional things to consider if you end up taking your QuickJack outside:

- **Extreme environmental conditions must be avoided.** The QuickJack warranty does not cover damage from rain, snow, sleet, excessive humidity, corrosive agents, hazardous and/or combustible fibers and flyings, or other contaminants. Keep your QuickJack protected from these environmental conditions at all times.
- **The QuickJack lifetime may be reduced.** Taking a QuickJack outside means it is subject to a harsher environment: a QuickJack ages more quickly the more it is outside.
- **Maintenance and replacement parts costs may increase.** The longer you keep your QuickJack outside, even when protected from the weather, the more often it will need maintenance: metal parts rust, plastic parts break down and dry out, hydraulic fluid gets dirty faster, and so on. Keeping your QuickJack outside for long periods is usually going to require extra maintenance and more frequent replacement parts.

Here are some things customers have told us they did with QuickJacks they took outside:

- **Move it back inside when done.** It may seem obvious, but here it is: when you are done with your QuickJack outside, even if it was protected from the weather, bring it back inside and thoroughly clean it.
- **Cover the Power Unit. *This one is really important.*** The Power Unit includes an electric motor. If that motor gets wet, people could get electrocuted, a fire could start, and almost certainly the motor will short circuit and stop functioning. ***These things are not covered by the QuickJack warranty.*** This advice applies your QuickJack at all times; *keep the Power Unit protected from all sources of moisture.*
- **Put up a carport canopy, party tent, or other structure.** And then put the QuickJack under the structure. It blocks the sun and the rain, reducing the impact the outside environment has on the QuickJack.
- **Use Ground Fault Circuit Interrupter (GFCI) protection.** If available, use a GFCI circuit breaker in the service panel (breaker box) to protect the entire circuit. Also referred to as Residual Current Devices (RCD).
- **Increase the maintenance.** If the maintenance instructions say to do something every day, check it twice a day; if they say to do something once a week, check it two times a week; and so on. This will help minimize the impact the outside environment has on your QuickJack.
- **Increase the replacement parts.** Parts on a QuickJack you take outside are not going to last as long as normal. Be prepared to start ordering replacement parts sooner.

Troubleshooting

This section describes how to troubleshoot your QuickJack. All repair work must be done by qualified personnel.

⚠ WARNING *Only use factory-supplied parts as replacement parts.* If you use parts from a different source, you void your warranty and compromise the safety of everyone who uses the QuickJack.

Note: If your QuickJack is not functioning correctly, you **must** stop using it until it is fixed.

If you continue to have an issue, visit quickjack.com/support or contact QuickJack Support at support@quickjack.com, **(888) 262-3880**, or **(805) 933-9970**.

Issue	Action to Take
Frames do not go up or down.	Make sure the Power Unit is getting appropriate power; if not, check the circuit breaker. Make sure none of the Hydraulic Hoses are pinched or leaking. Make sure there is sufficient Hydraulic Fluid in the Fluid Reservoir. Bleed the cylinders.
Frames do not come down.	Make sure there is a Vehicle on the Frames; if not, add one (the QuickJack is designed to work with weight). Check the pressure in the Air Cylinders; inflate to 40 to 50 psi, but do not exceed 50 psi.
Frames are stuck at full height with no weight.	QuickJack Frames require weight to come down from a fully raised position. Refer to Frames at Full Height with No Load .
Frames, loaded with Vehicle, will not lower to the ground.	Check the pressure in the Air Cylinders; inflate to 40 to 50 psi (2.75 – 3.4 Bar), but do not exceed 50 psi (3.4 Bar). If this does not correct the issue, contact QuickJack Technical Support at support@quickjack.com , or call (888) 262-3880 or (805) 933-9970 .
Frames do not rise from a zero net rise position.	QuickJack Frames cannot raise a full load from a completely flat position. Refer to Vehicle with No Tires Fully Lowered .
Hydraulic Fluid is dirty.	Replace the dirty Hydraulic Fluid with clean fluids.
Jack makes odd noises	Lubricate hinge points using white lithium grease.
Frames lower without using the Pendant Control.	Make sure the QuickJack is engaged on a locking position (if it is not, the Frames will slowly lower).
Air Cylinder is not holding pressure.	Make sure the valve core inside the valve stem is tightly in place; that is, it is not letting air escape. You can use a standard valve tool to check. Do not overtighten the valve core.
Quick-Connect Fittings becoming increasingly difficult to connect.	Pressure is building up in the hydraulic system. To release it, hold Down on the Pendant Control for ~5 seconds after the Frames reach the ground, allowing as much Hydraulic Fluid as possible to return to the Fluid Reservoir.

Issue	Action to Take
Frames stop raising before reaching the Top Locking Position	There is not enough Hydraulic Fluid in the reservoir. Return the QuickJack Frames to the ground, then add fluid to the reservoir to .5 inch below the fill hole.
No pressure from pump.	Prime the pump.

Frames at Full Height with No Load

The issue is that the QuickJack is designed and engineered to work with the weight of a Vehicle on it. If there is no Vehicle on the Frames at full height, the QuickJack can occasionally get stuck.

Do not raise the QuickJack Frames unless there is the weight of a Vehicle on them.

Methods that have fixed this issue include:

- Use lifting equipment to get weight onto the QuickJack Frames.
- Reduce the hydraulic force that is holding the QuickJack Frames. If you do this, keep a rag handy in case there is some Hydraulic Fluid leakage.

If you are still unable to lower the frames, contact QuickJack Technical Support for assistance.

Vehicle with No Tires Fully Lowered

The issue is that there is too much weight on the QuickJack Frames with no room to get upward force started. You need to reduce the weight by at least half or raise the Vehicle off the QuickJack Frames some different way.

Methods that have fixed this issue include:

- Use a floor jack to raise the Vehicle from four to six inches.
- Using lifting equipment to raise the Vehicle.

If you are still unable to raise your Vehicle, contact QuickJack Technical Support for assistance at support@quickjack.com, or call **(888) 262-3880** or **(805) 933-9970**.

Priming the Pump

Priming the pump pushes Hydraulic Fluid into the system. On rare occasions, there may not be enough Hydraulic Fluid in the system for the pump to produce force. Priming the pump usually resolves this issue.

Note that if your Power Unit does not have a Relief Valve, you **cannot** prime it.

A video of how to [Prime your QuickJack Power Unit is available online](#).

⚠ CAUTION Safety glasses and gloves are required for this procedure.

NOTICE There may be minor differences in the look and feel between Power Units. Nevertheless, all Power Units of the same type provide the same level of functionality.

To prime the pump:

1. On a flat and solid surface, place the Power Unit on its back.
2. Identify the Relief Valve located under the two Quick-Connect Fittings (5550413).
3. Remove the Relief Valve Assembly, as shown below. **Make sure to remove the complete assembly, and not just the Cap.**

Power Unit:

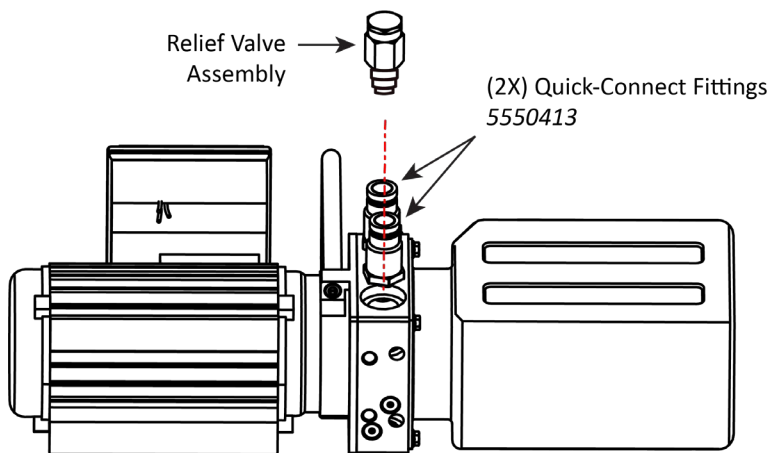

Pendant Control:

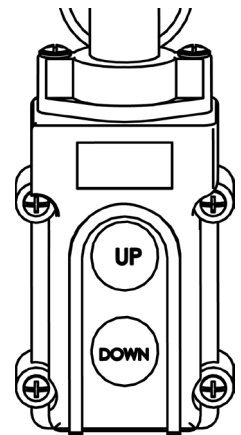

4. Place a shop rag over the cavity and hold it there with your thumb.
5. Press **Up** on the Pendant Control for a few seconds until you feel Hydraulic Fluid penetrate through the Shop Rag.
6. Reinstall the Relief Valve Assembly.

The pump should now have enough Hydraulic Fluid to operate normally.

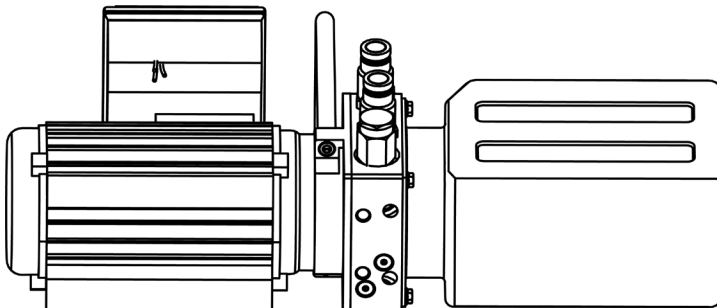

Relieving Hydraulic Pressure from the Hydraulic Hoses

After placing both Frames on a Locking Position, customers occasionally fail to hold down the **Down** Button for an extra five seconds to relieve the Hydraulic Pressure in the Hoses. Failure to do so makes it extremely difficult to reconnect the Hydraulic Hoses after they have been disconnected.

Important Do *not* press the Seal on the Quick Disconnect Fittings in an effort to release the pressure, Hydraulic Fluid will spray out from the Hydraulic Hoses while under pressure.

 **WARNING** Hydraulic Fluid under pressure is dangerous. You must wear OSHA-approved (publication 3151) Personal Protective Equipment *at all times* when handling hydraulic components: eye protection and leather gloves are mandatory.

How to release Hydraulic Pressure from the Hydraulic Hoses:

1. Release the air pressure from the Air Cylinder by pressing the Pin in the Shrader Valve.
2. Reconnect the Hydraulic Hoses at the Quick-Disconnect Fittings.
3. Press **Up** on the Pendant Control to raise the Frames up and off the Locking Position.
4. Completely lower the Lift back to the ground.
5. Re-pressurize the Air Cylinder to 40-50 psi.

Wiring Diagrams

Always follow the 208-230 VAC electrical rules for the country in which you are using the unit.

208 - 240 VAC Wiring Diagram (CE-approved)

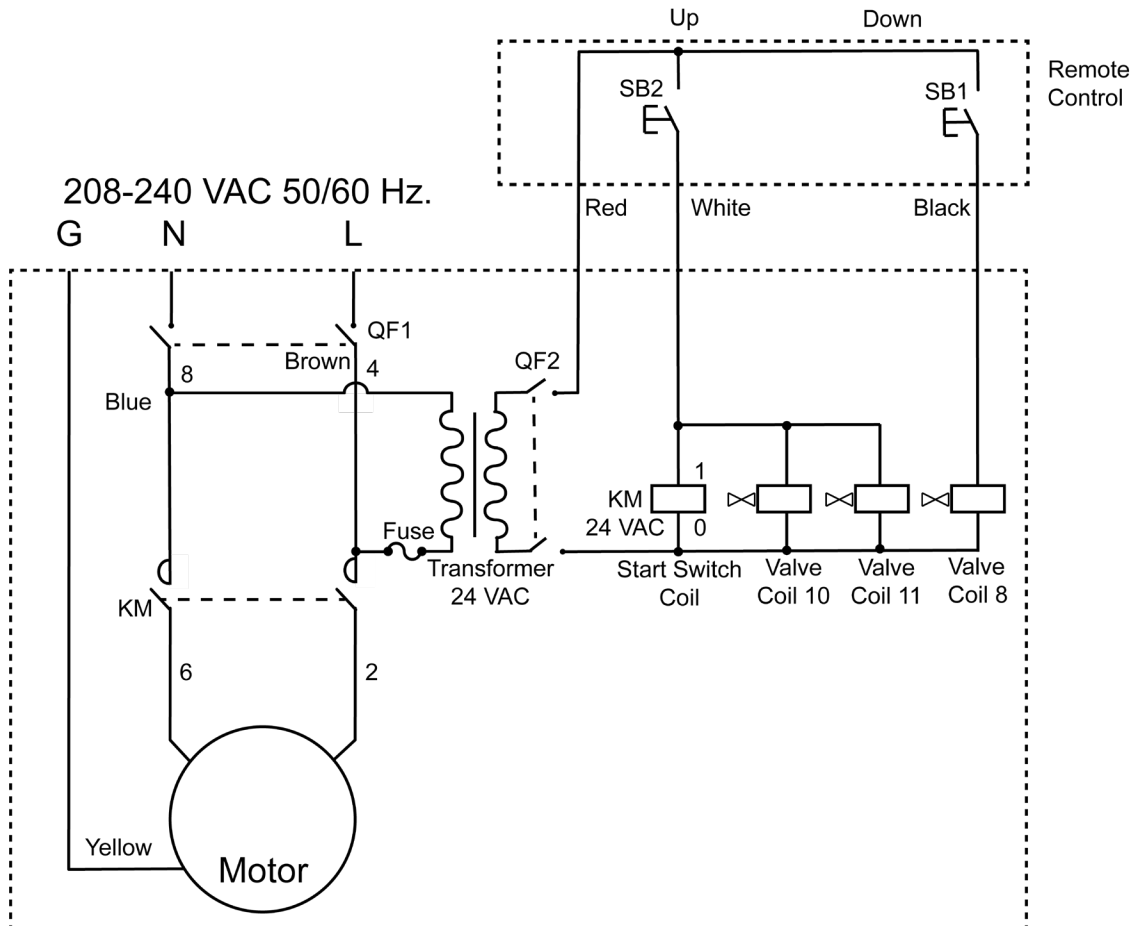

CE/UKCA approved Power Units:

- 5585360
- 5585760
- 5585739

A

7000TL

QUICKJACK™ 7000TL

NET FRAME WT. EA.: 97.75 lbs | POIDS NET DU CADRE: 44.5 kg | MAX. CAPACITY / PAIR: 7,000 lbs | CAPACITÉ MAX. / PAIRE: 3,175 kg

WARNING / AVERTISSEMENT: RANGER / RANGER CANNOT BE RESPONSIBLE FOR DAMAGE OR INJURY RESULTING FROM LACK OF MAINTENANCE OR UNSAFE USE OF THIS PRODUCT. READ AND UNDERSTAND ALL WARNINGS AND INSTRUCTIONS BEFORE USE.

IMPORTANT OPERATION INSTRUCTIONS:
 - Use on level floor surface only.
 - Always check vehicle weight before attempting to use this equipment.
 - RUBBER CONTACT BLOCKS must only be used on the RUBBER CONTACT BLOCK TRAYS. DO NOT attempt to raise any load on the upper frame rails. Use RUBBER CONTACT BLOCKS only.
 - Always inspect all components for damage prior to use. Any damage to fluid, DO NOT USE THIS EQUIPMENT.

HYDRAULIC POWER SYSTEM WARNINGS:
 - All hose couplers must be correctly and completely fastened together before using this equipment or applying pressure.
 - NEVER ATTEMPT to connect or disconnect hose couplers while hydraulic system is under pressure.
 - Never attempt to clean or bleed air. Consult agent for refilling the system.
 - Care must be taken to ensure that type or thread standard does not enter the hydraulic system. Type or thread standard is that will accept fluid from existing system installation.

INSTRUCTIONS D'UTILISATION:
 - Utilisez sur une surface de sol ferme et de niveau.
 - Toujours vérifier le poids total de charge du véhicule avant d'essayer d'utiliser ce matériel.
 - Les CALES D'APPUI EN CAOUTCHOUC doivent toujours être placées dans les TRAYS EN CAOUTCHOUC. NE PAS tenter de lever une charge sur les rails supérieurs du cadre. Utilisez impérativement les CALES D'APPUI EN CAOUTCHOUC.
 - Vérifier minutieusement le cadre de tous les composants avant utilisation. En cas de dommages, NE PAS UTILISER CE MATÉRIEL.

MISES EN GARDE CONCERNANT L'ALIMENTATION:
 - Tous les raccords de tuyau doivent être correctement et complètement attachés avant d'utiliser ce matériel ou de le mettre sous pression.
 - NE JAMAIS TENTER de raccorder ni déconnecter des raccords de tuyaux alors que le système hydraulique est sous pression.
 - Ne tentez jamais de nettoyer ou de purger le système hydraulique sans avoir consulté l'agent pour le remplissage de ce système.
 - Prenez soin d'éviter toute pollution de votre sol ou d'échappement dans le circuit hydraulique. Le placement de votre sol ou d'échappement dans le système hydraulique entrave son bon fonctionnement et provoque des problèmes de fonctionnement.

USE ONLY AS ILLUSTRATED / UTILISER UNiquement COMME ILLUSTRÉ

CE mark and other markings are present on the product. See the label for more information. © 2012 QuickJack, Inc. All rights reserved. PN 5905693

Right Frame Only

PN 5905693

B

QUICKJACK™ 7000TL

NET FRAME WT. EA.: 97.75 lbs | POIDS NET DU CADRE: 44.5 kg | MAX. CAPACITY / PAIR: 7,000 lbs | CAPACITÉ MAX. / PAIRE: 3,175 kg

WARNING / AVERTISSEMENT: RANGER / RANGER CANNOT BE RESPONSIBLE FOR DAMAGE OR INJURY RESULTING FROM LACK OF MAINTENANCE OR UNSAFE USE OF THIS PRODUCT. READ AND UNDERSTAND ALL WARNINGS AND INSTRUCTIONS BEFORE USE.

IMPORTANT OPERATION INSTRUCTIONS:
 - Use on level floor surface only.
 - Always check vehicle weight before attempting to use this equipment.
 - RUBBER CONTACT BLOCKS must only be used on the RUBBER CONTACT BLOCK TRAYS. DO NOT attempt to raise any load on the upper frame rails. Use RUBBER CONTACT BLOCKS only.
 - Always inspect all components for damage prior to use. Any damage to fluid, DO NOT USE THIS EQUIPMENT.

HYDRAULIC POWER SYSTEM WARNINGS:
 - All hose couplers must be correctly and completely fastened together before using this equipment or applying pressure.
 - NEVER ATTEMPT to connect or disconnect hose couplers while hydraulic system is under pressure.
 - Never attempt to clean or bleed air. Consult agent for refilling the system.
 - Care must be taken to ensure that type or thread standard does not enter the hydraulic system. Type or thread standard is that will accept fluid from existing system installation.

INSTRUCTIONS D'UTILISATION:
 - Utilisez sur une surface de sol ferme et de niveau.
 - Toujours vérifier le poids total de charge du véhicule avant d'essayer d'utiliser ce matériel.
 - Les CALES D'APPUI EN CAOUTCHOUC doivent toujours être placées dans les TRAYS EN CAOUTCHOUC. NE PAS tenter de lever une charge sur les rails supérieurs du cadre. Utilisez impérativement les CALES D'APPUI EN CAOUTCHOUC.
 - Vérifier minutieusement le cadre de tous les composants avant utilisation. En cas de dommages, NE PAS UTILISER CE MATÉRIEL.

MISES EN GARDE CONCERNANT L'ALIMENTATION:
 - Tous les raccords de tuyau doivent être correctement et complètement attachés avant d'utiliser ce matériel ou de le mettre sous pression.
 - NE JAMAIS TENTER de raccorder ni déconnecter des raccords de tuyaux alors que le système hydraulique est sous pression.
 - Ne tentez jamais de nettoyer ou de purger le système hydraulique sans avoir consulté l'agent pour le remplissage de ce système.
 - Prenez soin d'éviter toute pollution de votre sol ou d'échappement dans le circuit hydraulique. Le placement de votre sol ou d'échappement dans le système hydraulique entrave son bon fonctionnement et provoque des problèmes de fonctionnement.

USE ONLY AS ILLUSTRATED / UTILISER UNiquement COMME ILLUSTRÉ

CE mark and other markings are present on the product. See the label for more information. © 2012 QuickJack, Inc. All rights reserved. PN 5905693

Left Frame Only

PN 5905693

C

7000TLX

QUICKJACK™ 7000TLX

NET FRAME WT. EA.: 100 lbs | POIDS NET DU CADRE: 45 kg | MAX. CAPACITY / PAIR: 7,000 lbs | CAPACITÉ MAX. / PAIRE: 3,175 kg

WARNING / AVERTISSEMENT: RANGER / RANGER CANNOT BE RESPONSIBLE FOR DAMAGE OR INJURY RESULTING FROM LACK OF MAINTENANCE OR UNSAFE USE OF THIS PRODUCT. READ AND UNDERSTAND ALL WARNINGS AND INSTRUCTIONS BEFORE USE.

IMPORTANT OPERATION INSTRUCTIONS:
 - Use on level floor surface only.
 - Always check vehicle weight before attempting to use this equipment.
 - RUBBER CONTACT BLOCKS must only be used on the RUBBER CONTACT BLOCK TRAYS. DO NOT attempt to raise any load on the upper frame rails. Use RUBBER CONTACT BLOCKS only.
 - Always inspect all components for damage prior to use. Any damage to fluid, DO NOT USE THIS EQUIPMENT.

HYDRAULIC POWER SYSTEM WARNINGS:
 - All hose couplers must be correctly and completely fastened together before using this equipment or applying pressure.
 - NEVER ATTEMPT to connect or disconnect hose couplers while hydraulic system is under pressure.
 - Never attempt to clean or bleed air. Consult agent for refilling the system.
 - Care must be taken to ensure that type or thread standard does not enter the hydraulic system. Type or thread standard is that will accept fluid from existing system installation.

INSTRUCTIONS D'UTILISATION:
 - Utilisez sur une surface de sol ferme et de niveau.
 - Toujours vérifier le poids total de charge du véhicule avant d'essayer d'utiliser ce matériel.
 - Les CALES D'APPUI EN CAOUTCHOUC doivent toujours être placées dans les TRAYS EN CAOUTCHOUC. NE PAS tenter de lever une charge sur les rails supérieurs du cadre. Utilisez impérativement les CALES D'APPUI EN CAOUTCHOUC.
 - Vérifier minutieusement le cadre de tous les composants avant utilisation. En cas de dommages, NE PAS UTILISER CE MATÉRIEL.

MISES EN GARDE CONCERNANT L'ALIMENTATION:
 - Tous les raccords de tuyau doivent être correctement et complètement attachés avant d'utiliser ce matériel ou de le mettre sous pression.
 - NE JAMAIS TENTER de raccorder ni déconnecter des raccords de tuyaux alors que le système hydraulique est sous pression.
 - Ne tentez jamais de nettoyer ou de purger le système hydraulique sans avoir consulté l'agent pour le remplissage de ce système.
 - Prenez soin d'éviter toute pollution de votre sol ou d'échappement dans le circuit hydraulique. Le placement de votre sol ou d'échappement dans le système hydraulique entrave son bon fonctionnement et provoque des problèmes de fonctionnement.

USE ONLY AS ILLUSTRATED / UTILISER UNiquement COMME ILLUSTRÉ

CE mark and other markings are present on the product. See the label for more information. © 2012 QuickJack, Inc. All rights reserved. PN 5905694

Right Frame Only

PN 5905694

D

QUICKJACK™ 7000TLX

NET FRAME WT. EA.: 100 lbs | POIDS NET DU CADRE: 45 kg | MAX. CAPACITY / PAIR: 7,000 lbs | CAPACITÉ MAX. / PAIRE: 3,175 kg

WARNING / AVERTISSEMENT: RANGER / RANGER CANNOT BE RESPONSIBLE FOR DAMAGE OR INJURY RESULTING FROM LACK OF MAINTENANCE OR UNSAFE USE OF THIS PRODUCT. READ AND UNDERSTAND ALL WARNINGS AND INSTRUCTIONS BEFORE USE.

IMPORTANT OPERATION INSTRUCTIONS:
 - Use on level floor surface only.
 - Always check vehicle weight before attempting to use this equipment.
 - RUBBER CONTACT BLOCKS must only be used on the RUBBER CONTACT BLOCK TRAYS. DO NOT attempt to raise any load on the upper frame rails. Use RUBBER CONTACT BLOCKS only.
 - Always inspect all components for damage prior to use. Any damage to fluid, DO NOT USE THIS EQUIPMENT.

HYDRAULIC POWER SYSTEM WARNINGS:
 - All hose couplers must be correctly and completely fastened together before using this equipment or applying pressure.
 - NEVER ATTEMPT to connect or disconnect hose couplers while hydraulic system is under pressure.
 - Never attempt to clean or bleed air. Consult agent for refilling the system.
 - Care must be taken to ensure that type or thread standard does not enter the hydraulic system. Type or thread standard is that will accept fluid from existing system installation.

INSTRUCTIONS D'UTILISATION:
 - Utilisez sur une surface de sol ferme et de niveau.
 - Toujours vérifier le poids total de charge du véhicule avant d'essayer d'utiliser ce matériel.
 - Les CALES D'APPUI EN CAOUTCHOUC doivent toujours être placées dans les TRAYS EN CAOUTCHOUC. NE PAS tenter de lever une charge sur les rails supérieurs du cadre. Utilisez impérativement les CALES D'APPUI EN CAOUTCHOUC.
 - Vérifier minutieusement le cadre de tous les composants avant utilisation. En cas de dommages, NE PAS UTILISER CE MATÉRIEL.

MISES EN GARDE CONCERNANT L'ALIMENTATION:
 - Tous les raccords de tuyau doivent être correctement et complètement attachés avant d'utiliser ce matériel ou de le mettre sous pression.
 - NE JAMAIS TENTER de raccorder ni déconnecter des raccords de tuyaux alors que le système hydraulique est sous pression.
 - Ne tentez jamais de nettoyer ou de purger le système hydraulique sans avoir consulté l'agent pour le remplissage de ce système.
 - Prenez soin d'éviter toute pollution de votre sol ou d'échappement dans le circuit hydraulique. Le placement de votre sol ou d'échappement dans le système hydraulique entrave son bon fonctionnement et provoque des problèmes de fonctionnement.

USE ONLY AS ILLUSTRATED / UTILISER UNiquement COMME ILLUSTRÉ

CE mark and other markings are present on the product. See the label for more information. © 2012 QuickJack, Inc. All rights reserved. PN 5905694

Left Frame Only

PN 5905694

E

QUICKJACK™ 1645 Lemonwood Dr. Santa Paula, CA USA

MODEL NUMBER / NUMÉRO DE MODÈLE

DESCRIPTION

LIFT CAPACITY (PAIR) / CAPACITÉ DE LEVAGE (PAIRE)

DATE CODE / CODE DATE

UPC / CUP

SERIAL NUMBER / NUMÉRO DE SÉRIE

⚠ DANGER!
 Disconnect Power Before Servicing / Déconnecter l'alimentation avant toute intervention.

WARRANTY VOID IF DATA PLATE IS REMOVED / GARANTIE NULLE SI LA PLAQUE DE DATE A ÉTÉ ENLEVÉE

MADE IN CHINA / FABRIQUÉ EN CHINE

PN 5905433

F

CERTIFIED AUTOMOTIVE LIFT

INDEPENDENTLY TESTED AND VALIDATED

ALI CERTIFIED
 To the provisions of ANSI/UL ALCTV-2017 SAFETY REQUIREMENTS FOR CONSTRUCTION, TESTING AND VALIDATION

Automotive Lift Institute, Inc. | Cortland, NY 13045

MET LISTED
 Conforms to ANSI/UL 2017 SAFETY STANDARD FOR GARAGE EQUIPMENT

MET LISTED
 MET Laboratories, Inc. BALTIMORE, MD 21208

Certification Label Serial Number

AL00617000N

PN 5905653

G

QUICKJACK™

PN 5905745

PN 5905745

H

WARNING SAFETY LOCK DEVICE Always confirm in locked position when platforms are raised.

AVERTISSEMENT MÉCANISME DE VERROUILLAGE Toujours vérifier qu'il est en position verrouillée lorsque les plateformes sont levées.

PN 5905428

I

CAUTION KEEP HANDS CLEAR OF PINCH POINTS. DO NOT ATTEMPT TO LIFT ANY LOAD ON UPPERFRAME RAILS. USE RUBBER CONTACT BLOCKS ONLY.

ATTENTION TENIR LES MAINS À L'ÉCART DES POINTS DE PINCEMENT. NE PAS TENTER DE LEVER DES CHARGES PAR LES RAILS SUPÉRIEURS DU CADRE. UTILISER LES CALES D'APPUI EN CAOUTCHOUC.

PN 5905429

J

CAUTION

POSITION JACK FRAMES UNDER PARKED VEHICLE. NEVER DRIVE OVER OR ON TOP OF JACK FRAMES.

MISE EN GARDE

PLACER LES CADRES DE LEVAGE SOUS LE VÉHICULE STATIONNÉ. NE JAMAIS ROULER SUR OU AU-DESSUS DES CADRES DE LEVAGE.

PN 5905432

K

ATTENTION

MAX. CAPACITY / PAIR: 7,000 LBS.
CAPACITÉ MAX. / PAIRE: 3,175 KG

PN 5905438

L

DANGER

AVOID SERIOUS INJURY OR DEATH FROM EXPLOSION. MAXIMUM PRESSURE ON AIR BOTTLE SHOULD NOT EXCEED 50-PSI/3.4 BAR WITH JACK FRAMES IN FULLY LOWERED POSITION. LOCK-OUT POWER SOURCE AND BLEED OFF AIR PRESSURE BEFORE SERVICING.

ÉVITER LES BLESSURES GRAVES ET LA MORT PAR EXPLOSION. LA PRESSION MAXIMALE SUR LE RÉSERVOIR D'AIR NE DOT PAS DÉPASSER 50 PSI/3.4 BAR LORSQUE LES CADRES DE LEVAGE SONT DANS LA POSITION LA PLUS BASSE. VERROUILLER LA SOURCE D'ALIMENTATION ET PURGER LA PRESSION D'AIR AVANT TOUTE INTERVENTION.

PN 5905434

M

CAUTION ROUTE HYDRAULIC LINE UNDER THIS SECTION OF THE FRAME.

ATTENTION PASSER LA LIGNE HYDRAULIQUE SOUS CETTE PARTIE DU CADRE.

PN 5905036

Parts Sheets

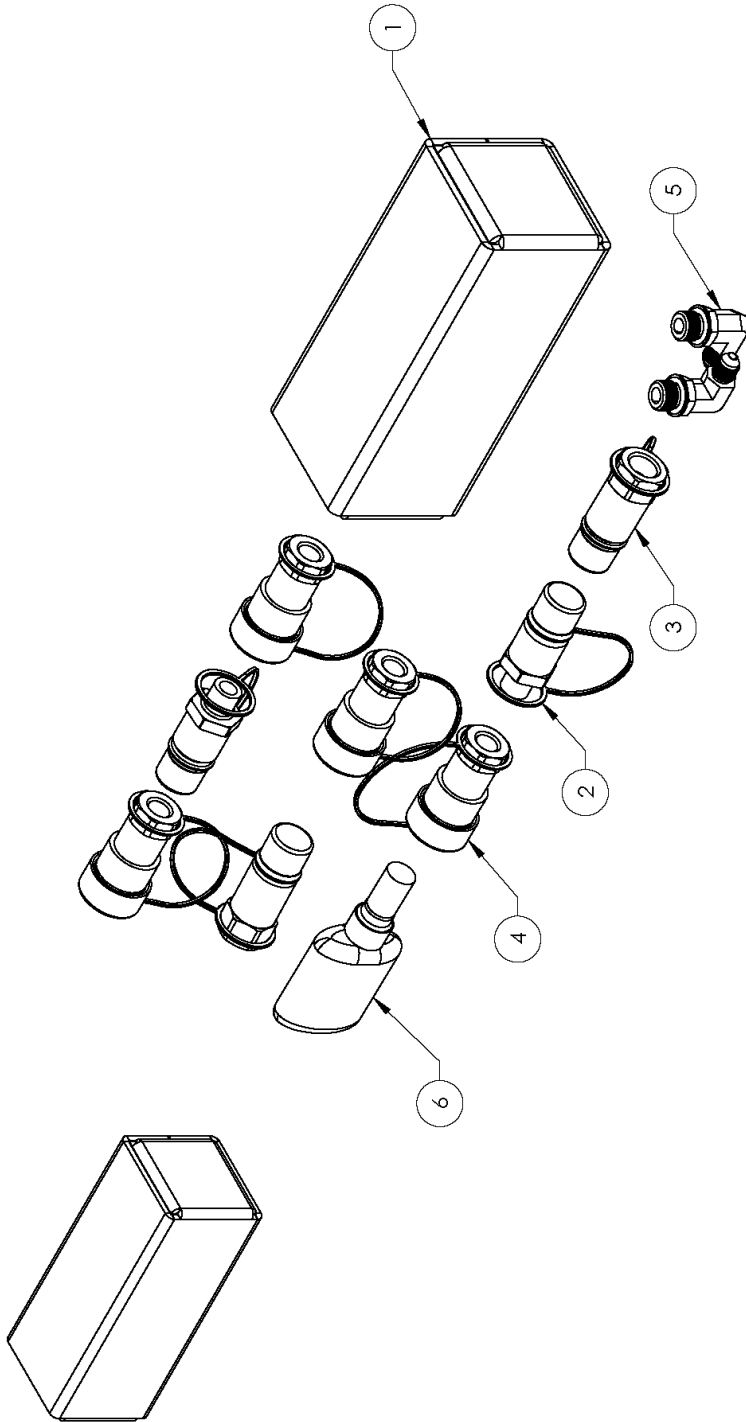

ITEM NO	PART NUMBER	DESCRIPTION	QTY	REV
1	5910092	QUICKJACK PARTS BAG BOX	1	B
2	5550413	FIG NPL-06 ORB x 1/4 NS; QUICK-CON COUP MALE	2	--
3	5550032	FIG NPL-04 NPT FX 1/4 QUICK-CONNECTOR COUPLER MALE; NON SPILL DESIGN	2	--
4	5550031	FIG NPL-04 NPT F X 1/4 QUICK-CONNECTOR COUPLER FEMALE; NON SPILL DESIGN	4	--
5	5550103	FIG ELB-04 JIC -06 ORB	2	--
6	5580012	LIQUID PTFE THREAD SEALANT .50ml	1	--

DO NOT SCALE DRAWING		NAME	DATE
DRAWN	TIA	10/28/2019	
CHECKED	OR	09/03/2020	
THIRD ANGLE PROJECTION			
PROPRIETARY AND CONFIDENTIAL THE INFORMATION CONTAINED HEREIN IS THE SOLE PROPERTY OF BENDPAK INC. ANY REPRODUCTION OR TRANSMISSION OF THIS INFORMATION WITHOUT THE WRITTEN PERMISSION OF BENDPAK INC. IS PROHIBITED.			

		DIMENSIONS ARE IN MM
--	--	----------------------

BP BendPak® 1645 LEMONWOOD DR. SANTA PAULA, CA 93060	
TITLE:	QUICKJACK PARTS BAG
SEE DWG. NO.	A
REV	B
5174043	
SCALE: 1:3	SHEET 1 OF 1

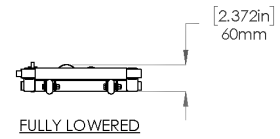
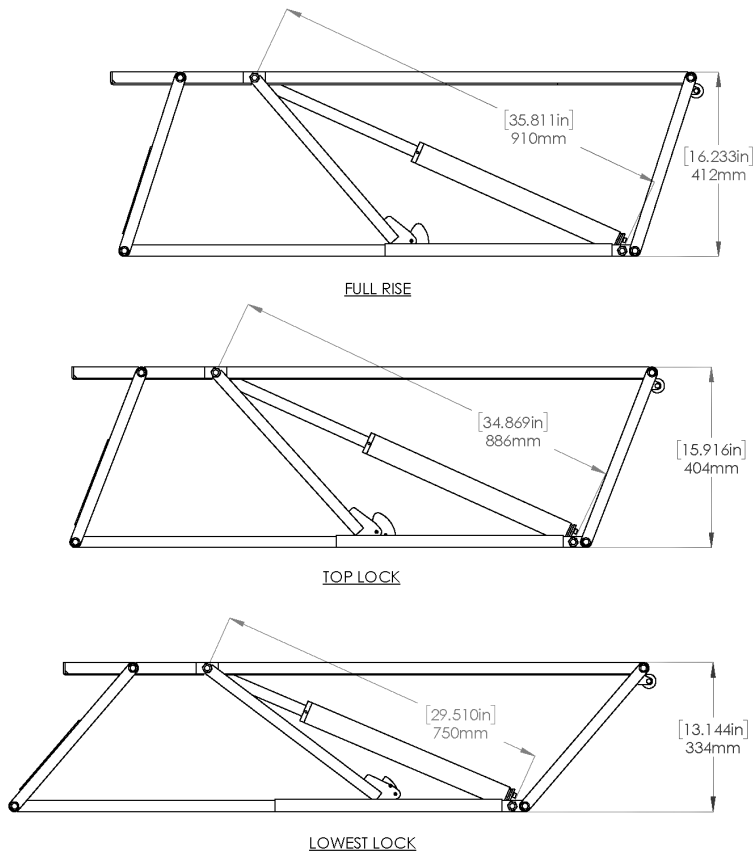

BP BendPak.	
1645 LEMONWOOD DR. SANTA PAULA, CA 93060	
TITLE: 3500SLX FRAME ASSEMBLY	
SIZE: DWG. NO.	REV
A 5215416	U
SCALE: 1:10	SHEET 2 OF 2

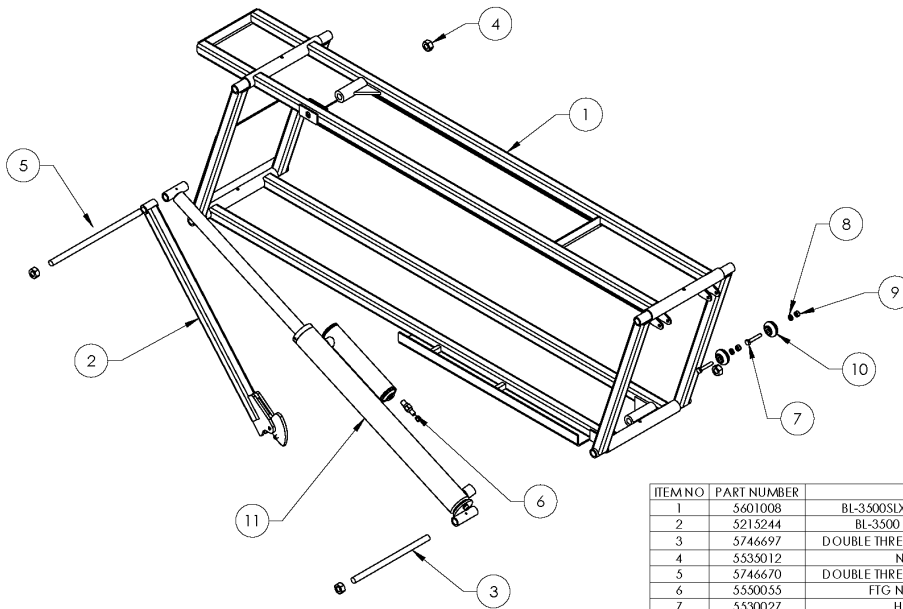

ITEM NO	PART NUMBER	DESCRIPTION	QTY	REV
1	5601008	BL-3500SLX FRAME WELDMENT, L.H.	1	K
2	5215244	BL-3500 SAFETY BAR ASSEMBLY	1	D
3	5746697	D DOUBLE THREADED ROD M12 x 1.75 x 212	1	B
4	5535012	NUT M12x1.75 NL	4	-
5	5746670	D DOUBLE THREADED ROD M12 x 1.75 x 254	1	G
6	5550055	FTG NPT -02 STM x -02 NPT	1	-
7	5530027	HHB M6 x 1.0 x 35	2	-
8	5545026	WASHER M6 x Ø12 SL	2	-
9	5535357	NUT M6 x 1.0 NL	2	-
10	5716192	QUICK JACK POLYURETHANE WHEEL	2	E
11	5502520	OFFSET CYLINDER ASSEMBLY Ø1.5 x 15	1	M

DO NOT SCALE DRAWING

NAME: TM DATE: 06/18/2015

CHECKED: OR DATE: 10/30/2020

DIMENSIONS ARE IN MM

THIRD ANGLE PROJECTION

BP BendPak.
 1645 LEMONWOOD DR.
 SANTA PAULA, CA 93060

TITLE: 3500SLX FRAME ASSEMBLY

SIZE: DWG. NO. **A** 5215416 REV U
 SCALE: 1:10 SHEET 1 OF 2

PROPRIETARY AND CONFIDENTIAL
 THE INFORMATION CONTAINED IN THIS DRAWING IS
 THE SOLE PROPERTY OF BENDPAK INC.
 REPRODUCTION IN PART OR AS A WHOLE WITHOUT
 THE WRITTEN PERMISSION OF BENDPAK INC. IS
 PROHIBITED.

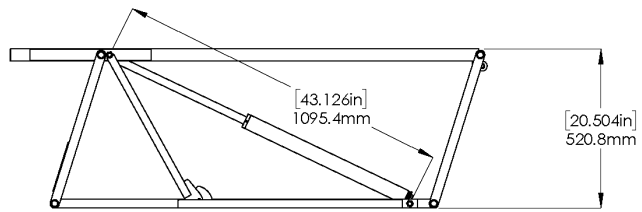

FULL RISE

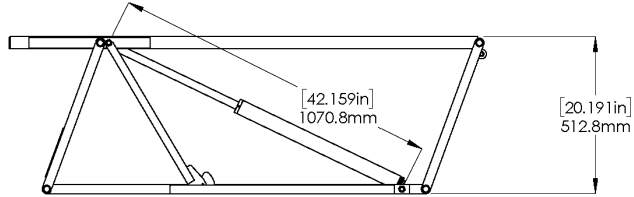

TOP LOCK

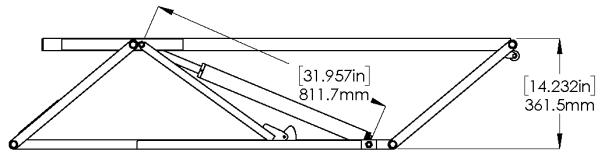

LOWEST LOCK

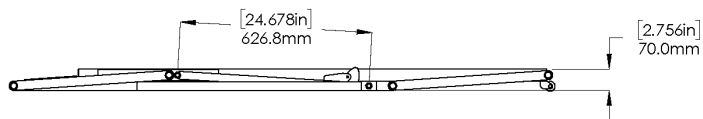

FULLY LOWERED

BendPak.
 1645 LEMONWOOD DR.
 SANTA PAULA, CA 93060

TITLE: 5000TL FRAME ASSEMBLY

SIZE DWG. NO. REV
 A 5215920 C

SCALE: 1:15 SHEET 2 OF 2

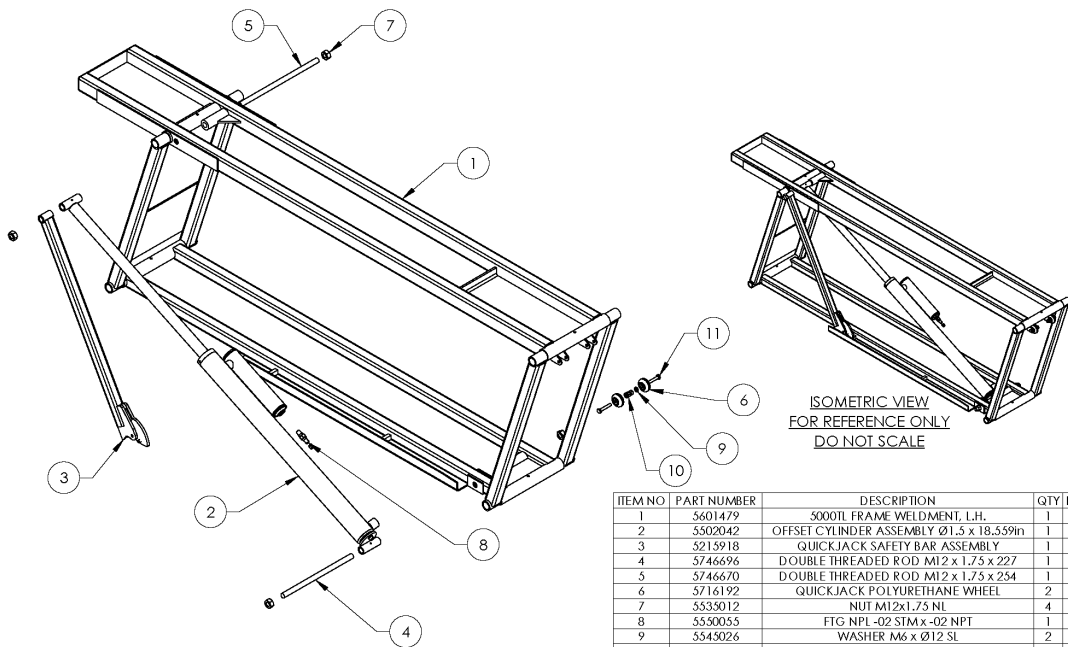

ISOMETRIC VIEW FOR REFERENCE ONLY
DO NOT SCALE

ITEM NO	PART NUMBER	DESCRIPTION	QTY	REV
1	5601479	5000TL FRAME WELDMENT, L.H.	1	D
2	5502042	OFFSET CYLINDER ASSEMBLY Ø1.5 x 18.559in	1	C
3	5215918	QUICKJACK SAFETY BAR ASSEMBLY	1	B
4	5746696	DOUBLE THREADED ROD M12 x 1.75 x 227	1	E
5	5746670	DOUBLE THREADED ROD M12 x 1.75 x 234	1	G
6	5714192	QUICKJACK POLYURETHANE WHEEL	2	E
7	5533012	NUT M12x1.75 NL	4	-
8	5550055	FIG NPT -02 STM x -02 NPT	1	-
9	5545026	WASHER M6 x Ø12 SL	2	-
10	5533357	NUT M6 x 1.0 NL	2	-
11	5530027	HHB M6 x 1.0 x 35	2	-

DO NOT SCALE DRAWING

DRAWN TM 04/03/2020
 CHECKED OR 01/25/2021

THIRD ANGLE PROJECTION

BendPak.
 1645 LEMONWOOD DR.
 SANTA PAULA, CA 93060

TITLE: 5000TL FRAME ASSEMBLY

SIZE DWG. NO. REV
 A 5215920 D

SCALE: 1:10 SHEET 1 OF 2

PROPRIETARY AND CONFIDENTIAL
 THIS DRAWING IS THE PROPERTY OF BENDPAK INC. AND IS NOT TO BE REPRODUCED OR TRANSMITTED IN ANY FORM OR BY ANY MEANS, ELECTRONIC OR MECHANICAL, WITHOUT THE WRITTEN PERMISSION OF BENDPAK INC. © 2020

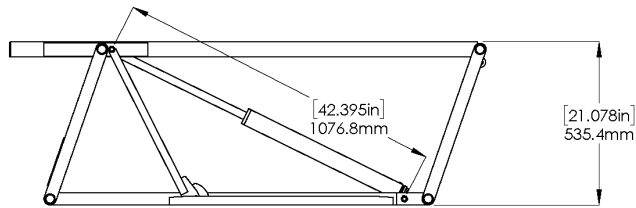

FULL RISE

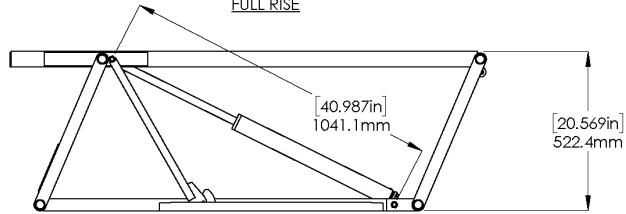

TOP LOCK

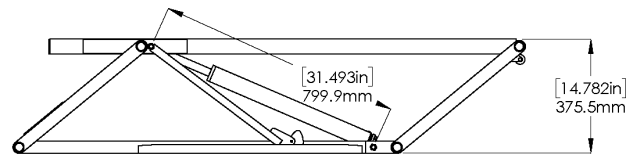

LOWEST LOCK

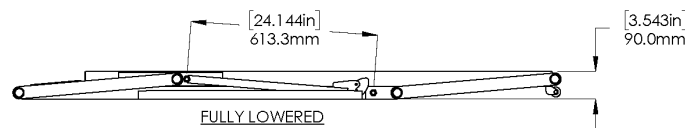

FULLY LOWERED

BP BendPak.
1645 LEMONWOOD DR.
SANTA PAULA, CA 93060

TITLE: 7000TL FRAME ASSEMBLY

SIZE	DWG. NO.	REV
A	5215919	D

SCALE: 1:15 SHEET 2 OF 2

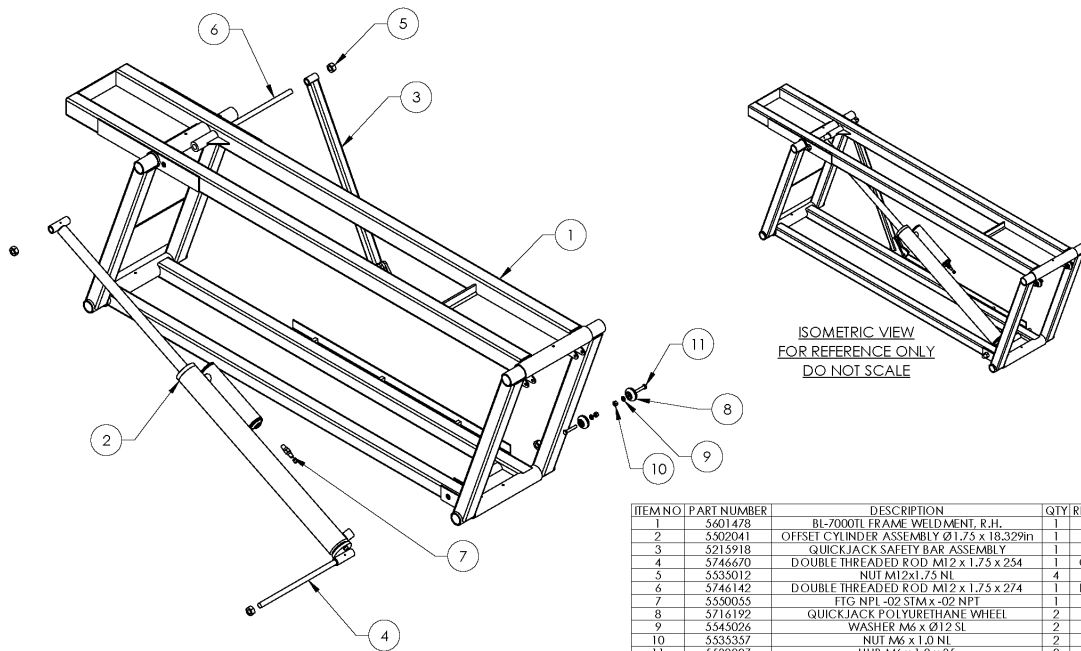

ISOMETRIC VIEW
FOR REFERENCE ONLY
DO NOT SCALE

ITEM NO	PART NUMBER	DESCRIPTION	QTY	REV
1	3601478	BL-7000TL FRAME WELDMENT, R.H.	1	B
2	5502041	OFFSET CYLINDER ASSEMBLY Ø1.75 x 18.329in	1	B
3	5215918	QUICK JACK SAFETY BAR ASSEMBLY	1	B
4	3746670	DOUBLE THREADED ROD M12 x 1.75 x 254	1	G
5	5535012	NUT M12x1.75 NL	4	-
6	3746142	DOUBLE THREADED ROD M12 x 1.75 x 274	1	D
7	5530055	FTG NPL -02 STM X -02 NPT	1	-
8	3716192	QUICK JACK POLYURETHANE WHEEL	2	E
9	5545026	WASHER M6 x Ø12 SL	2	-
10	5535357	NUT M6 x 1.0 NL	2	-
11	5530027	HHB M6 x 1.0 x 35	2	-

DO NOT SCALE DRAWING

DRAWN: TM 04/17/2020
CHECKED: OR 10/30/2020

THIRD ANGLE PROJECTION

BP BendPak.
1645 LEMONWOOD DR.
SANTA PAULA, CA 93060

TITLE: 7000TL FRAME ASSEMBLY

SIZE	DWG. NO.	REV
A	5215921	B

SCALE: 1:10 SHEET 1 OF 2

PROPRIETARY AND CONFIDENTIAL
NO INFORMATION DISCLOSED TO THE TRADE OR
BE SOLE PROPERTY OF BENDPAK INC. ANY
REPRODUCTION IN WHOLE OR IN PART WITHOUT
THE WRITTEN PERMISSION OF BENDPAK INC. IS
PROHIBITED.

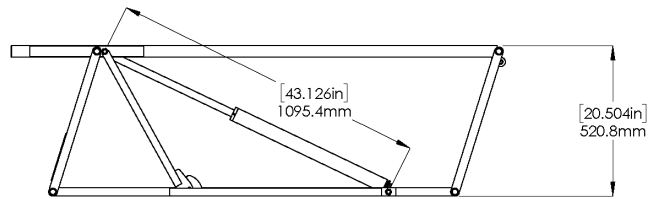

FULL RISE

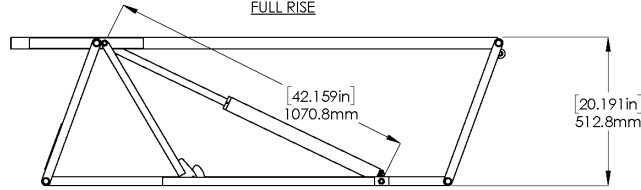

TOP LOCK

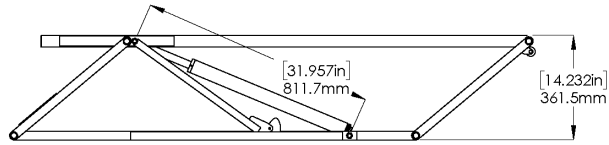

LOWEST LOCK

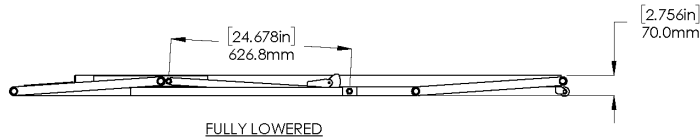

FULLY LOWERED

BendPak.
 1645 LEMONWOOD DR.
 SANTA PAULA, CA 93060

TITLE: 5000TLX FRAME ASSEMBLY

SIZE DWG. NO. REV
A 5215924 **B**

SCALE: 1:15 SHEET 2 OF 2

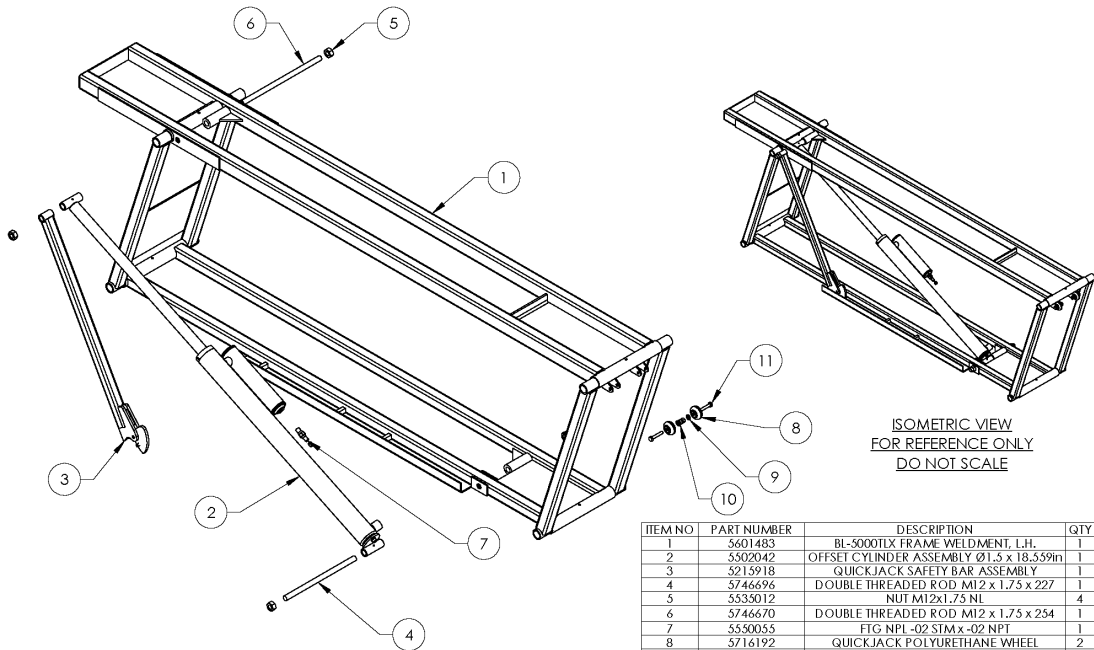

ITEM NO.	PART NUMBER	DESCRIPTION	QTY	REV
1	5601483	BL-5000TLX FRAME WELDMENT, L.H.	1	B
2	5502042	OFFSET CYLINDER ASSEMBLY Ø1.5 x 18.559in	1	B
3	5215918	QUICK JACK SAFETY BAR ASSEMBLY	1	B
4	5746696	DOUBLE THREADED ROD M12 x 1.75 x 227	1	E
5	5535012	NUT M12x1.75 NL	4	-
6	5746670	DOUBLE THREADED ROD M12 x 1.75 x 254	1	G
7	5550055	FTG NPI -02 STM x -02 NPT	1	-
8	5716192	QUICK JACK POLYURETHANE WHEEL	2	E
9	5545026	WASHER M6 x Ø12 SL	2	-
10	5535357	NUT M6 x 1.0 NL	2	-
11	5530027	HHB M6 x 1.0 x 35	2	-

DO NOT SCALE DRAWING

NAME: DATE: **BendPak.**
 1645 LEMONWOOD DR.
 SANTA PAULA, CA 93060

DRAWN: TM 04/03/2020
 CHECKED: OR 10/30/2020

THIRD ANGLE PROJECTION

TITLE: 5000TLX FRAME ASSEMBLY

SIZE DWG. NO. REV
A 5215924 **B**

SCALE: 1:10 SHEET 1 OF 2

PROPRIETARY AND CONFIDENTIAL
 THE INFORMATION CONTAINED ON THIS DRAWING IS
 THE SOLE PROPERTY OF BENDPAK, INC.
 REPRODUCTION IN PART OR AS A WHOLE WITHOUT
 THE WRITTEN PERMISSION OF BENDPAK, INC. IS
 PROHIBITED.

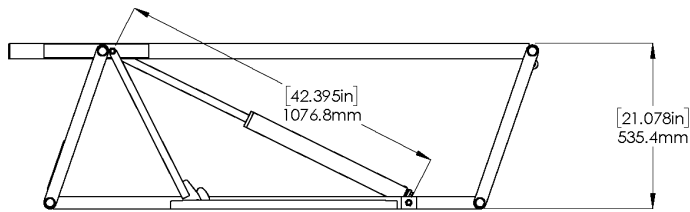

FULL RISE

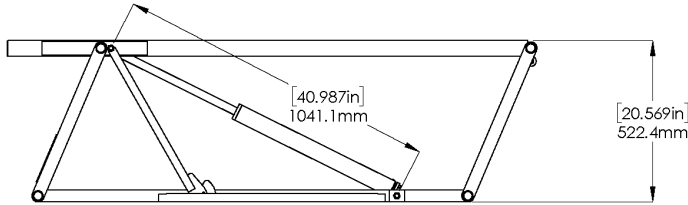

TOP LOCK

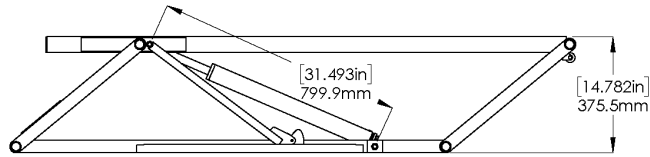

LOWEST LOCK

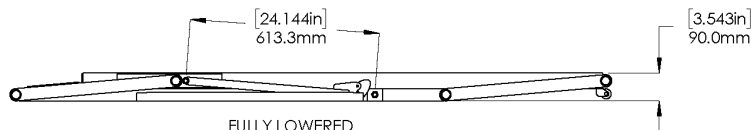

FULLY LOWERED

BendPak		
1645 LEMONWOOD DR. SANTA PAULA, CA 93060		
TITLE: 7000TLX FRAME ASSEMBLY		
SIZE	DWG. NO.	REV
A	5215923	D
SCALE: 1:15		SHEET 2 OF 2

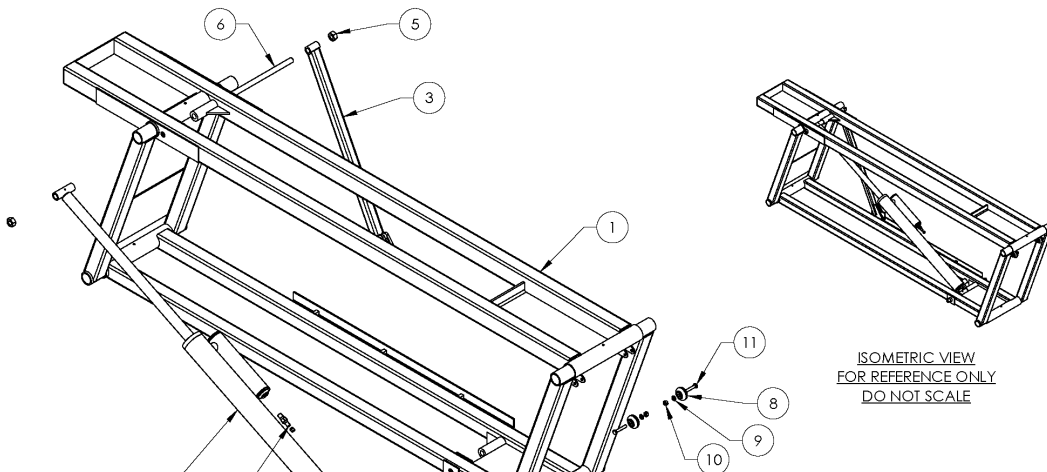

ITEM NO	PART NUMBER	DESCRIPTION	QTY	REV
1	5601482	BL-7000TLX FRAME WELDMENT, R.H.	1	B
2	5502041	OFFSET CYLINDER ASSEMBLY Ø1.75 x 18.329in	1	B
3	5215918	QUICK JACK SAFETY BAR ASSEMBLY	1	B
4	5746670	DOUBLE THREADED ROD M12 x 1.75 x 254	1	G
5	5535012	NUT M12x1.75 NL	4	-
6	5746142	DOUBLE THREADED ROD M12 x 1.75 x 274	1	D
7	5530055	FTG NPT-02 STMx-02 NPT	1	-
8	5716192	QUICK JACK POLYURETHANE WHEEL	2	E
9	5545026	WASHER M6 x Ø12 SL	2	-
10	5535357	NUT M6 x 1.0 NL	2	-
11	5530027	HHB M6 x 1.0 x 35	2	-

DRAWN		TM	04/15/2020	BendPak	
CHECKED		OR	10/30/2020	1645 LEMONWOOD DR. SANTA PAULA, CA 93060	
THIRD ANGLE PROJECTION			TITLE: 7000TLX FRAME ASSEMBLY		
SIZE		DWG. NO.	REV		
A		5215925	B		
SCALE: 1:10			SHEET 1 OF 2		

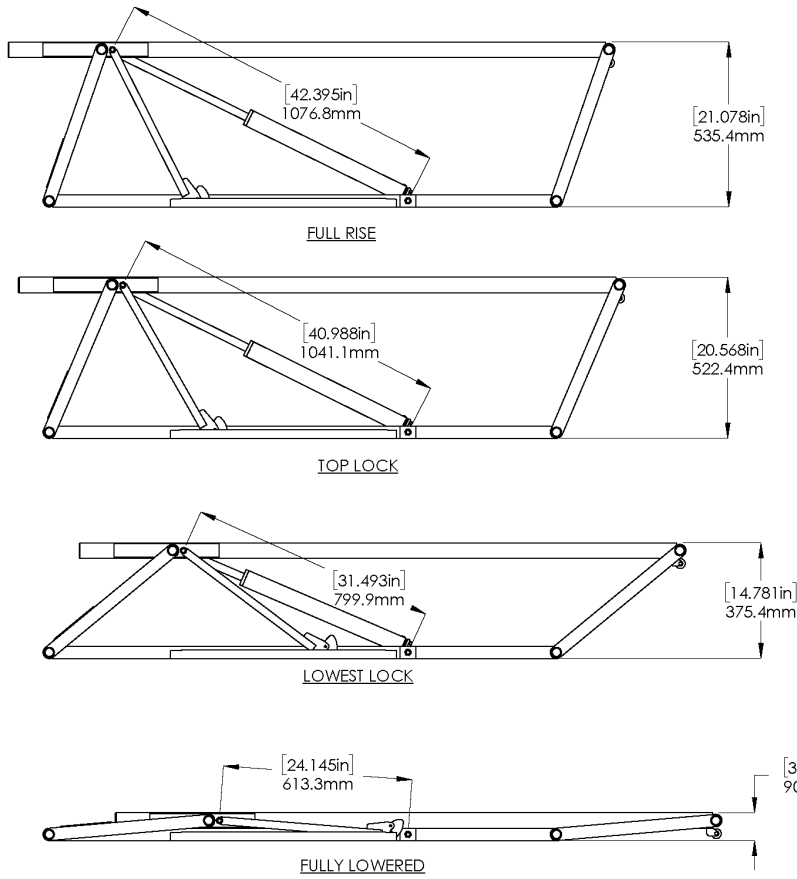

EP BendPak.
 1645 LEMONWOOD DR.
 SANTA PAULA, CA 93060

TITLE: 6000ELX FRAME ASSEMBLY

SEE DWG. NO.	REV
A 5215937	D

SCALE: 1:15 SHEET 2 OF 2

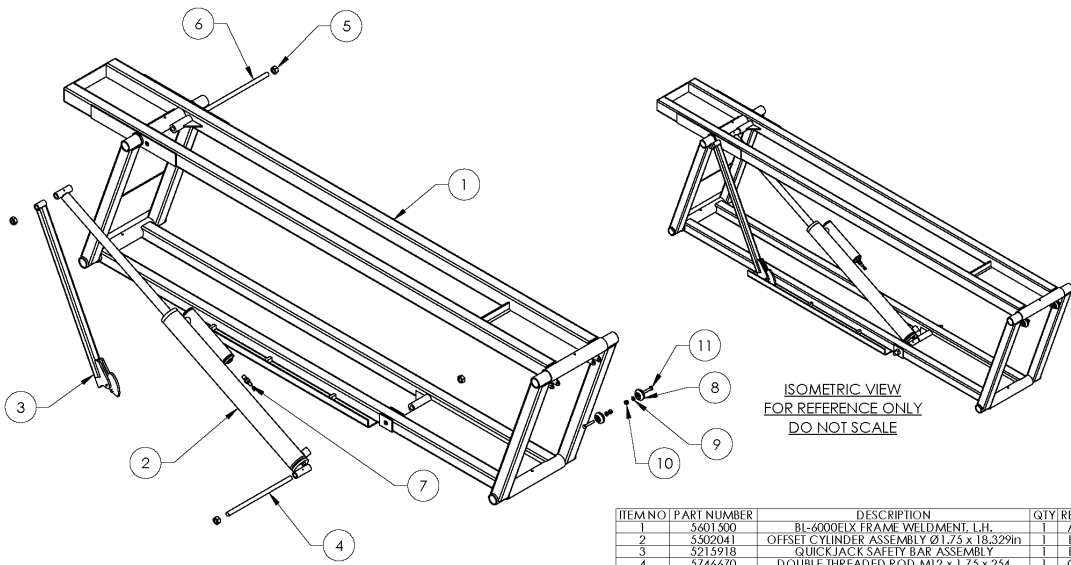

ITEM NO.	PART NUMBER	DESCRIPTION	QTY	REV
1	5601300	BL-6000ELX FRAME WELDMENT, L.H.	1	A
2	5302041	OFFSET CYLINDER ASSEMBLY Ø1.75 x 18.329in	1	B
3	5215918	QUICKJACK SAFETY BAR ASSEMBLY	1	B
4	5746670	DOUBLE THREADED ROD, M12 x 1.75 x 254	1	C
5	5335012	NUT M12x1.75 NL	4	-
6	5746142	DOUBLE THREADED ROD, M12 x 1.75 x 274	1	D
7	5350055	FTG NPT -02 STM x -02 NPT	1	-
8	5716192	QUICKJACK POLYURETHANE WHEEL	2	E
9	5545026	WASHER M6 x Ø12 SL	2	-
10	5335357	NUT M6 x 1.0 NL	2	-
11	5330027	HHB M6 x 1.0 x 35	2	-

DO NOT SCALE DRAWING

NAME	DATE
TM	05/28/2020
OR	10/30/2020

EP BendPak.
 1645 LEMONWOOD DR.
 SANTA PAULA, CA 93060

TITLE: 6000ELX FRAME ASSEMBLY

SIZE DWG. NO.	REV
A 5215937	B

SCALE: 1:12 SHEET 1 OF 2

PROPRIETARY AND CONFIDENTIAL
 THE INFORMATION CONTAINED IN THIS DRAWING IS THE SOLE PROPERTY OF BENDPAK INC. AND IS NOT TO BE REPRODUCED OR TRANSMITTED IN ANY FORM OR BY ANY MEANS WITHOUT THE WRITTEN PERMISSION OF BENDPAK INC. © 2020

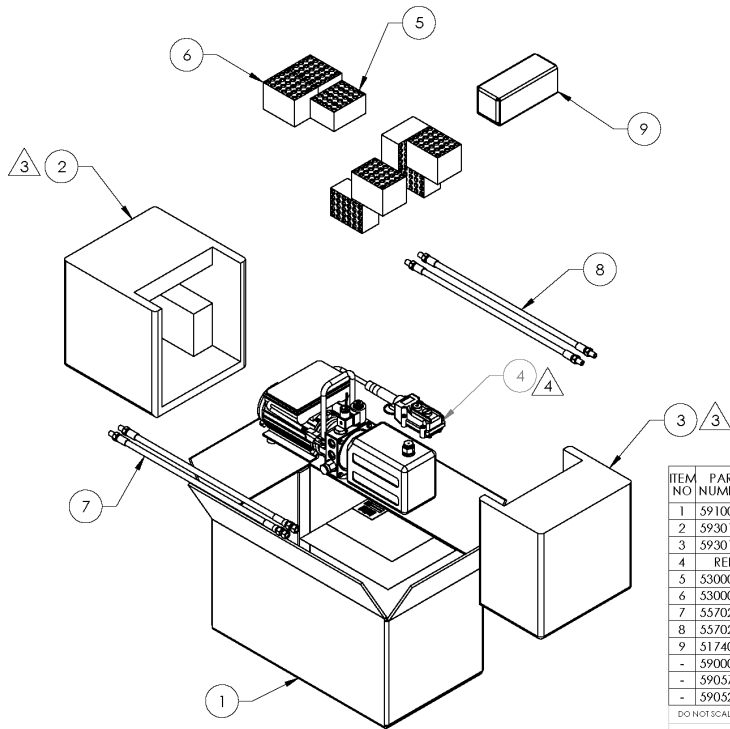

ITEM NO	PART NUMBER	DESCRIPTION	QTY	REV
1	5910038	QUICKJACK SLX/TL/ELX PRINTED BOX 3 ENG-FRE	1	A
2	5930171	QUICKJACK POWER UNIT BOX STYROFOAM PACKAGING, MOTOR	1	--
3	5930169	QUICKJACK POWER UNIT BOX STYROFOAM PACKAGING, TANK	1	--
4	REF	QUICKJACK POWER UNIT AC-110	1	--
5	5300014	55mm DIMPLED RUBBER PAD	4	A
6	5300016	75mm DIMPLED RUBBER PAD	4	A
7	5570233	HOSE ASSEMBLY Ø6.4 x 1005mm	2	B
8	5570216	HOSE ASSEMBLY Ø6.4 x 3734mm DS MALE	2	B
9	5174043	QUICKJACK PARTS BAG	1	B
-	5900088	DO NOT RETURN SHEET	1	-
-	5905756	DO NOT RETURN LABEL	1	-
-	5905250	QUICKJACK BOX 3 UPC-LOT NUMBER PACKAGING LABEL	1	-

DO NOT SCALE DRAWING		NAME	DATE	BendPak 1645 LEMONWOOD DR. SANTA PAULA, CA 93060
DRAWN	CA	12/21/2020		
CHECKED				TITLE: QUICKJACK SLX/TL/ELX BOX 3 OF 3 EN-FR: 110V AC
DIMENSIONS ARE IN MM		THIRD ANGLE PROJECTION		SEE DWG. NO. A 5174064
				REV C
<small>PROPRIETARY AND CONFIDENTIAL THE INFORMATION CONTAINED IN THIS DRAWING IS THE SOLE PROPERTY OF BENDPAK INC. ANY REPRODUCTION IN PART OR AS A WHOLE WITHOUT THE WRITTEN PERMISSION OF BENDPAK INC. IS PROHIBITED.</small>				SCALE: 1:10 SHEET 1 OF 1

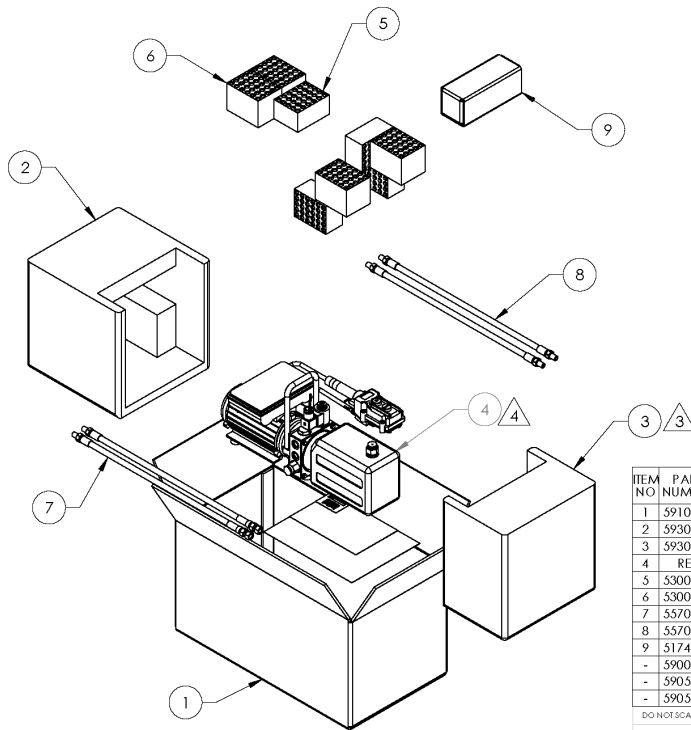

ITEM NO	PART NUMBER	DESCRIPTION	QTY	REV
1	5910038	QUICKJACK SLX/TL/ELX PRINTED BOX 3 ENG-FRE	1	A
2	5930171	QUICKJACK POWER UNIT BOX STYROFOAM PACKAGING, MOTOR	1	--
3	5930169	QUICKJACK POWER UNIT BOX STYROFOAM PACKAGING, TANK	1	--
4	REF	QUICKJACK POWER UNIT 208-240V AC	1	--
5	5300014	55mm DIMPLED RUBBER PAD	4	A
6	5300016	75mm DIMPLED RUBBER PAD	4	A
7	5570233	HOSE ASSEMBLY Ø6.4 x 1005mm	2	B
8	5570216	HOSE ASSEMBLY Ø6.4 x 3734mm DS MALE	2	B
9	5174043	QUICKJACK PARTS BAG	1	B
-	5900088	DO NOT RETURN SHEET	1	-
-	5905756	DO NOT RETURN LABEL	1	-
-	5905250	QUICKJACK BOX 3 UPC-LOT NUMBER PACKAGING LABEL	1	-

DO NOT SCALE DRAWING		NAME	DATE	BendPak 1645 LEMONWOOD DR. SANTA PAULA, CA 93060
DRAWN	CA	12/21/2020		
CHECKED				TITLE: QUICKJACK SLX/TL/ELX BOX 3 OF 3 EN-FR: 220V AC
DIMENSIONS ARE IN MM		THIRD ANGLE PROJECTION		SEE DWG. NO. A 5174065
				REV C
<small>PROPRIETARY AND CONFIDENTIAL THE INFORMATION CONTAINED IN THIS DRAWING IS THE SOLE PROPERTY OF BENDPAK INC. ANY REPRODUCTION IN PART OR AS A WHOLE WITHOUT THE WRITTEN PERMISSION OF BENDPAK INC. IS PROHIBITED.</small>				SCALE: 1:10 SHEET 1 OF 1

Declaration of Conformity

CE Declaration of Conformity

The equipment which accompanies this declaration is in conformity with EU Directives:

2006/42/EC Machinery Directive
2011/65/EU RoHS 2

Manufacturer

BendPak Inc.
1645 E. Lemonwood Drive,
Santa Paula, CA,
United States of America

Authorised Representative in the EU

Flexrep EU OÜ
Attn: E-Residency Hub
Ahtri tn 12, 10151 Tallinn, Estonia

A copy of the Technical file for this equipment is available from:

The EU address above

Description of Equipment

QuickJack range of dual platform short stroke, moveable, parallelogram vehicle servicing lifts
3500SLX 3500lbs/1588kg capacity
5000TL 5000lbs/2268kg capacity
5000EXT 5000lbs/2268kg capacity
5000TLX 5000lbs/2268kg capacity. Long frame
6000ELX 6000lbs/2722kg capacity. Extra-long frame
7000TL 7000lbs/3175kg capacity
7000TLX 7000lbs/3175kg capacity. Long frame
Hydraulic powerpacks drawing reference
5585360 (230VAC)
5585760 (230VAC)
5585739 (12VDC)

A sample of this machinery has been presented to Notified Body number 1105
CCQS Certification Services Ltd. Block B, The Crescent Building, Northwood, Santry, Dublin, D09 C6X8
Who have issued an EU type-examination certificate
Number CE-MI-20210618-01-16-5A dated September 2022

The equipment in respect of which this declaration is made conforms to the example to which that certificate relates,
and that certificate remains valid.

This declaration of conformity is issued under the sole responsibility of the manufacturer.

The following harmonised standards have been used:

EN ISO 12100:2010 Safety of machinery - Risk assessment
EN 1493:2010 Vehicle lifts
EN IEC 63000:2018 RoHS Documentation

Authorised signatory of Manufacturer



Signature:

Name of signatory: Jeffrey S. Kritzer

Position in company: President
Date signed: September 13, 2022

Place signed: Santa Paula, CA, USA

UKCA Declaration of Conformity

The equipment which accompanies this declaration is in conformity with UK Regulations

Supply of Machinery (Safety) Regulations (SI 2008 No 1597), as amended
Restriction of the Use of Certain Hazardous Substances in Electrical and Electronic Equipment Regulations 2012 (SI 2012/3032) as amended

Manufacturer

BendPak Inc.
1645 E. Lemonwood Drive,
Santa Paula, CA,
United States of America

A copy of the Technical file for this equipment is available from:

The above address

Description of Equipment

Machinery models:

3500SLX 1588 kg (3500 lb) capacity serial numbers XXXXX-00001-00000 to 99999-99999-99999
5000TL 2268 kg (5000 lb) capacity serial numbers XXXXX-00001-00000 to 99999-99999-99999
7000TL 3175 kg (7000 lb) capacity serial numbers XXXXX-00001-00000 to 99999-99999-99999
5000TLX: 2268 kg (5000 lb) capacity serial numbers XXXXX-00001-00000 to 99999-99999-99999
7000TLX: 3175 kg (7000 lb.) capacity serial numbers XXXXX-00001-00000 to 99999-99999-99999
6000ELX: 2721 kg (6000 lb) capacity serial numbers XXXXX-00001-00000 to 99999-99999-99999

Hydraulic power packs drawing reference:

5585360 (230VAC)
5585760 (230VAC)
5585739 (12VDC)

A sample of this machinery has been presented to Approved Body number 1105.

CCQS UK Ltd.25 Wilton Rd, Pimlico, London, SW1V 1LW, United Kingdom

Who have issued a type-examination certificate

Number CA-MU-20220228-02-01-5A dated September 2022

The equipment in respect of which this declaration is made conforms to the example to which that certificate relates, and that certificate remains valid.

The following designated standards have been used

EN ISO 12100:2010 Safety of machinery - Risk assessment
EN 1493:2010 Vehicle lifts
EN IEC 63000:2018 RoHS Documentation

Authorised signatory of manufacturer

Signature:



Position in company: President

Date signed: September 13, 2022

Name of signatory: Jeffrey S. Kritzer

Place signed: Santa Paula, CA, USA

Automotive Lift Institute (ALI) Store

You probably checked the **ALI's Directory of Certified Lifts** (www.autolift.org/ali-directory-of-certified-lifts/) before making your most recent Lift purchase, but did you know the **ALI Store** (www.autolift.org/ali-store/) offers a wide variety of professional, easy-to-use, and reasonably priced training and safety materials that will make your garage a safer place to work?

The ALI Store is your trusted source for workplace safety!



Lifting It Right Online Certificate Course. Make *sure* you and your people are lifting vehicles the right way.



ALI Lift Inspector Certification Program Registration. Become a ALI Certified Lift Inspector.

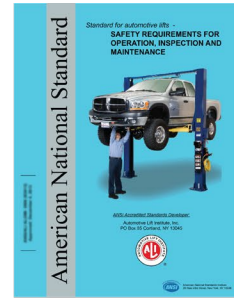

ANSI/ALI ALOIM Standard for Automotive Lifts. Safety Requirements for Operation, Inspection, and Maintenance.

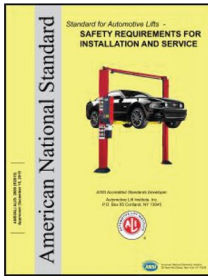

ANSI/ALI ALIS Standard. Safety Requirements for Installation and Service.

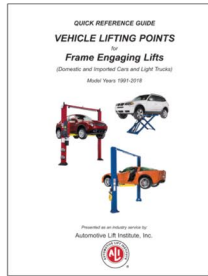

Guide to Identifying Vehicle Lifting Points for Frame-Engaging Lifts. Don't eyeball your lifting points, *know* where they are.



Lift Operator Safety Materials. Five safety documents in a single package.

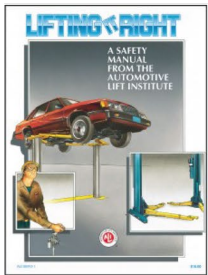

Lifting It Right. A hardcopy version of the *Lifting It Right* safety manual from the Automotive Lift Institute.

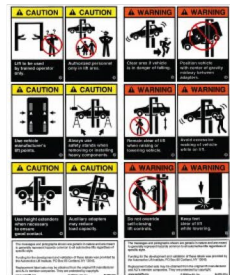

Uniform Warning Labels and Placards for 2-Posts. Labels in Mandarin, French Canadian, and Spanish are also available.



Safety Tips Card. Reminds your people of 13 key safety tips to follow daily.

Visit today and get the training and materials you need to work safely:
<http://www.autolift.org/ali-store/>



1645 Lemonwood Drive
Santa Paula, CA, 93060 USA