



MeacoDry Arete One

18L Dehumidifier and Air Purifier



Thank you for choosing Meaco, we really appreciate it.

Safety Information

This dehumidifier must not be used in rooms under the following conditions:

- Potentially explosive atmosphere
- Aggressive atmospheres
- Featuring a high concentration of solvents
- An extremely high ratio of dust

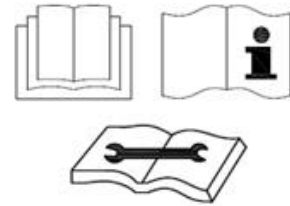

Keep Children Away: Do not allow children to play with or around this unit, which could result in injury. Be sure the unit is inaccessible to children when not attended. This appliance is not intended for use by person (including children) with reduced physical, sensory, or mental capabilities, or lack of experience and knowledge, unless they have been given supervision or instruction concerning use of the appliance by a person responsible for their safety.

Keep Unit Grounded: Always operate the unit with a grounding plug and a grounded electrical outlet. A grounding plug is an essential safety feature that helps reduce the risk of shock or fire.

Protect Power Cord from Damage: Never operate a unit with a damaged power cord, as this may lead to electrical or fire hazards. If the power supply cord is damaged, it must be replaced by a cord of the same type and amperage rating.

Extension Cords: Extension cords must be grounded and able to deliver the appropriate voltages to the unit.

Handle with Care: Do not drop, throw, or crash the dehumidifier. Rough treatment can damage the components or wiring and create a hazardous condition.

Run on Stable Surface: Always operate the unit on a stable, level surface, for example the floor or a strong counter, so that the dehumidifier cannot fall and cause injury.

Keep Out of Water: Never operate the unit in pooled or standing water, as this may create a risk of injury from electrical shock. Do not store or operate outdoors. If electrical wiring or components become wet, thoroughly dry them before using the unit. If in doubt do not use the dehumidifier and consult a qualified electrician or a Meaco approved engineer.

Keep Air Intakes Clear: Do not clog or block the air intakes by placing the dehumidifier too close to curtains, walls or anything that will restrict the air inlet. This may cause the unit to overheat and result in a fire or electrical hazard.

Keep Electrical Components Dry: Never allow water inside the dehumidifier's electrical components. If these areas become wet for any reason, thoroughly dry them before using the dehumidifier. If in doubt, do not use the dehumidifier and consult a qualified electrician or a Meaco approved engineer.

The operator must make the operating instruction available for the user and make sure that the user does understand the manual.

The MeacoDry Arete One dehumidifier uses the new R290 refrigerant gas to comply with European Environmental Directives. R290 is kinder to the environment and is part of attempts to reduce global warming as it has a low greenhouse effect (GWP).



When using the MeacoDry Arete One you must take into account the following:

- This dehumidifier uses about 65 grams of R290 refrigerant, which is flammable. Therefore, it is part of a sealed system and must only be serviced by a trained Meaco engineer.
- Do not use or store this dehumidifier in a room smaller than 4m² to prevent a fire or explosion hazard if there is a leak of refrigerant and the gas comes into contact with an ignition source.
- Do not use in a room with any continuous sources of ignition, for example open flames, gas fires or hobs, cigarettes, or any other sources of ignition.
- If the dehumidifier is installed, operated, or stored in a non-ventilated area, then the room must be designed to prevent the accumulation of refrigerant leaks resulting in a risk of fire or explosion due to ignition of the refrigerant caused by electric heaters, cookers, or other sources of ignition.
- R290 refrigerant gas is odourless.
- Do not puncture either during the units working life or after. At the end of life dispose of following local recycling regulations.
- If there is any damage to the dehumidifier then do not use it and contact Meaco or your retailer.
- As with all dehumidifiers, always keep upright and leave the dehumidifier standing upright for 8 hours before using it upon receipt.



Failure to comply with these instructions could result in fire, damage to property, serious injury or potentially death.

Individuals who operate or work on the refrigerant circuit must have the appropriate certification issued by a national accredited organisation that ensures competence in handling flammable refrigerants according to a specific evaluation recognised by national associations in the industry and compliant with the latest R290 guidance.

Servicing should only be carried out by a Meaco approved engineer using original Meaco parts to prevent damage to the unit and potential injury to the engineer.

Wiring Instructions

Should it be necessary to change the plug, please note the wires in the mains lead are coloured in accordance with the following code:

Blue: Neutral
 Brown: Live
 Green and yellow: Earth

As the colours of the wires in the mains lead of this appliance may not correspond with the coloured markings identifying the terminals in your plug, proceed as follows:

1. The **BLUE** wire is the NEUTRAL and must be connected to the terminal which is marked with the letter N or coloured **BLACK**.
2. The **BROWN** wire is the LIVE and must be connected to the terminal which is marked with the letter L or coloured **RED**.
3. The **GREEN/YELLOW** is the EARTH and must be connected to the terminal which is marked with the letter E or coloured **GREEN** or **GREEN/YELLOW**.
4. Always ensure that the cord grip is positioned and fastened correctly.
5. Only ever use the same fuse as fitted in the original product, if in doubt please contact Meaco first, or a qualified electrician.

Example wiring for a Standard British Plug:

Please note - The Earth Terminal is marked with the letter E or Earth Symbol .

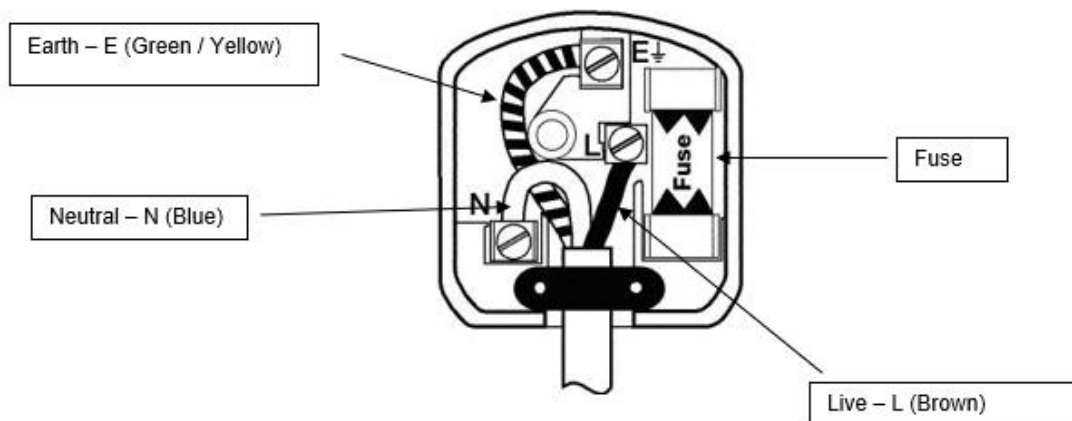

First Steps

When you first receive your dehumidifier, it is important you follow the steps below carefully.

1. Before putting your dehumidifier into operation for the first time, the instruction manual should be studied carefully.

2. You should check your dehumidifier and its box and packaging for any transport damage. In case of damage, you should inform Costco immediately.

3. Remove the dehumidifier from its box and packaging.

Keep hold of the box and packaging should your dehumidifier need to be transported for a service or repair in the future. Cut through the adhesive tape and fold up the box to make it easier to store.

4. Before turning the dehumidifier on, leave it to stand for 8 hours. This will allow any refrigerant that may have moved during transit to settle.

4. Choose where you would like to locate your dehumidifier (see page 6 for advice). This dehumidifier has been carefully designed allowing you to place the dehumidifier as close to a wall as you wish.

5. Insert the H13 HEPA filter that has been provided with your dehumidifier. This will enable air purification as well as dehumidification. For instructions on how to do this, see page 16.

6. Plug the dehumidifier into the mains and turn it on using the Power Button. When the dehumidifier is first switched on a number will appear on the display. Allow the dehumidifier to gauge an accurate reading of the humidity level in the environment it is situated in for the first 10 minutes.

7. Use page 6 to determine the correct setting for your dehumidifier usage.

8. If you have any further questions regarding the setup of your dehumidifier, please feel free to contact us on 01483 234900.

What can I use my dehumidifier for?

Dehumidifying your whole house

Your dehumidifier can be used to maintain an optimum humidity level throughout your house or flat. Moisture in the air from the entire house/flat will migrate towards the dehumidifier, reducing the humidity level. This will help reduce condensation on windows, prevent the build-up of mould and will make the space easier to heat, amongst other things. When doing so, we would recommend the following:

- Situate your dehumidifier in a central area (e.g., a landing or hallway)
- Keep your dehumidifier running 24/7
- Keep all internal doors open
- Keep external doors and windows closed
- Use smart humidity mode to set your dehumidifier to reach a target of 55%rh
- Insert a H13 HEPA filter to purify the air (for more information see page 16)

If you want to use your dehumidifier to reduce the humidity level in a single room or area of the house, use the same settings as above, however, situate the dehumidifier inside the 'problem' room or area and keep the internal door closed.

Using your dehumidifier to dry your laundry.

Dehumidifiers are very efficient at drying your laundry quickly and cheaply. When doing so, we would recommend the following:

- Situate your dehumidifier in a room with your laundry
- Place the dehumidifier close to your laundry but not too close that water could drip onto the dehumidifier
- Keep all doors and windows closed
- Use smart laundry mode to set your dehumidifier to run continuously for 6 hours

What do the readings on the display mean?

When the dehumidifier is turned on the reading on the display will show the current humidity level in the environment the dehumidifier is being used in. Press the smart humidity mode button once to see the target humidity level – the display will change for 5 seconds and then change back to the current humidity level.

Product Identification

The MeacoDry Arete dehumidifier will come complete with an instruction manual, a H13 HEPA filter and a right-angle adaptor to enable continuous drainage.

Front view

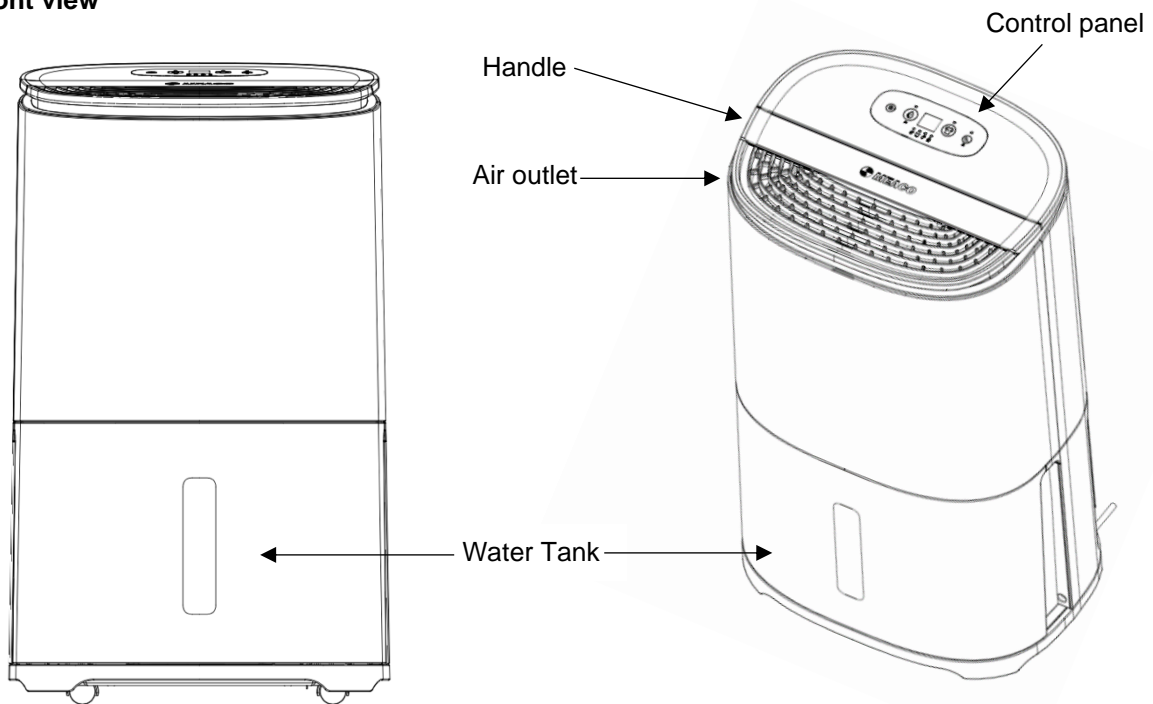

Side view

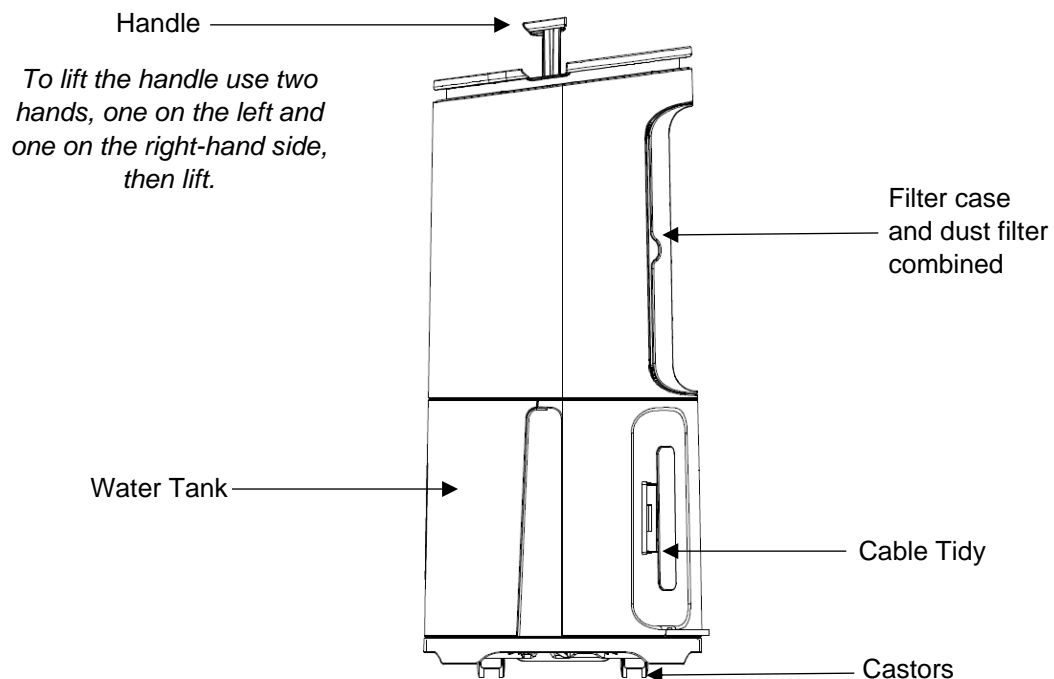

Rear view

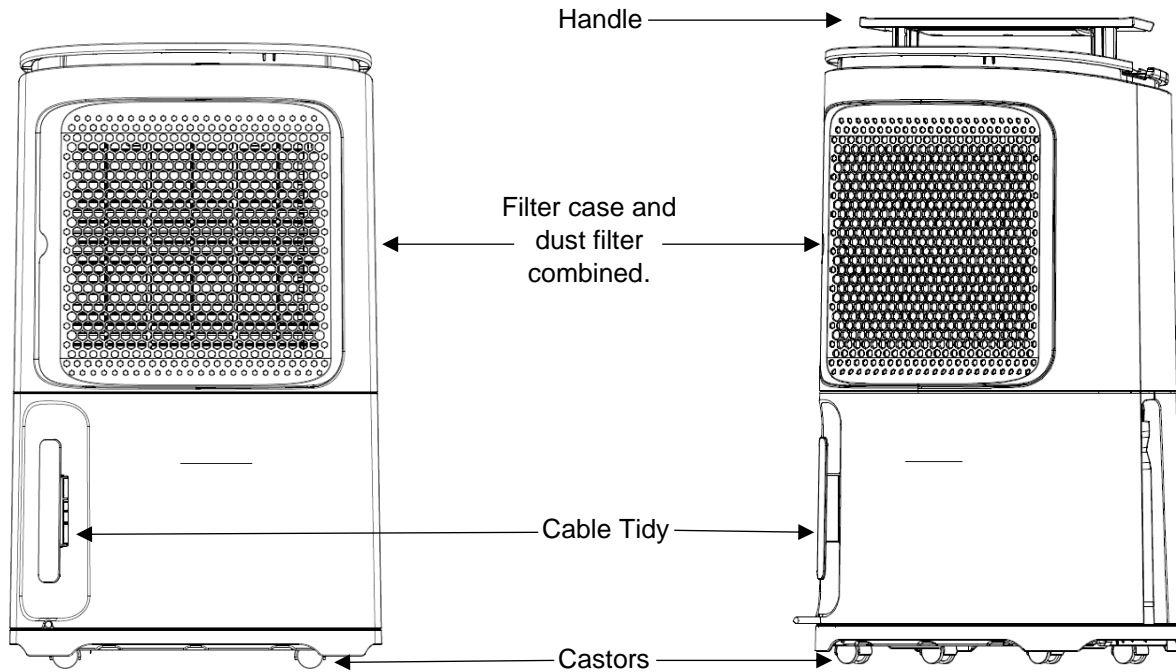

As a company we understand the urgency of Climate Change and recognise how important it is to play our part in becoming more environmentally friendly. In September 2019 we stopped providing hoses with our dehumidifiers to reduce the amount of plastic going to waste. To make things easier for our customers who wish to use continuous drainage, we have included an adaptor which fits a standard garden hose (ID: 12.5mm). For more information on how to use continuous drainage, see pages 13 and 14.

Control Panel

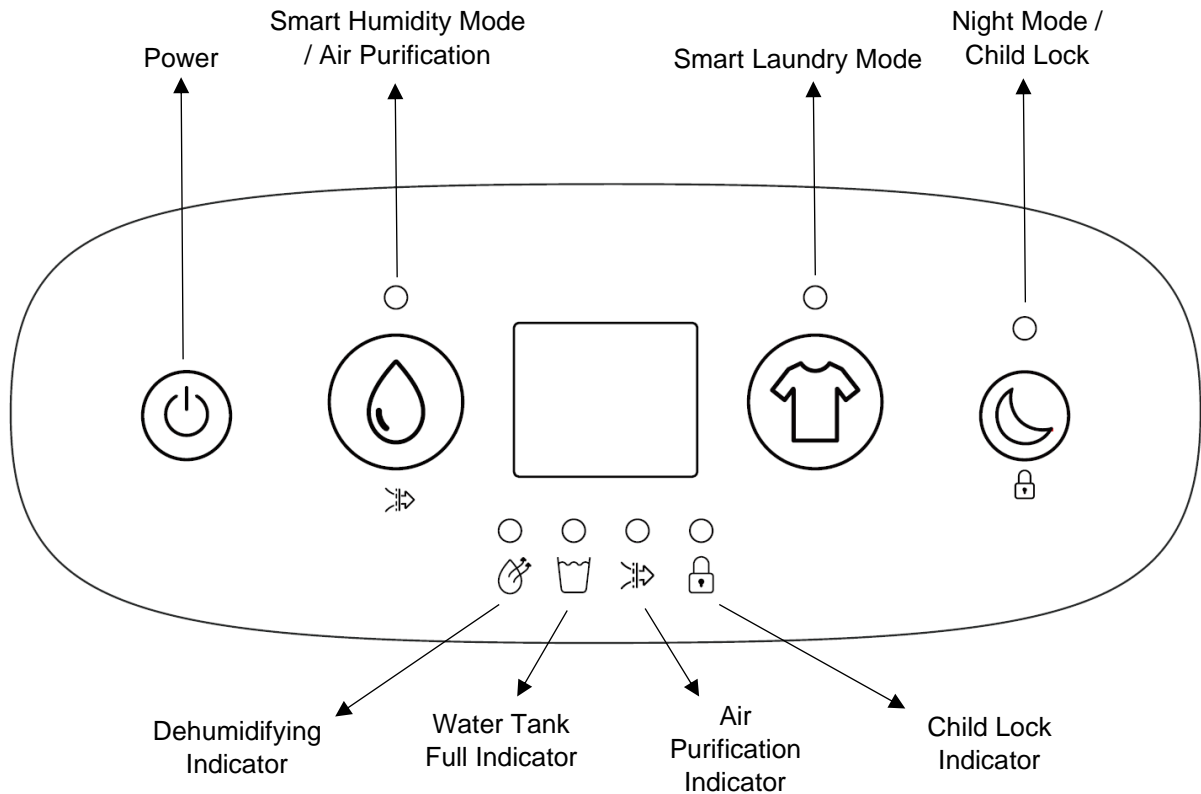

When the dehumidifier is first plugged into the mains it will bleep once, no lights will appear on the control panel. All buttons on the control panel only require a short press. Press the buttons firmly and quickly.

Power Button

Press the power button once to turn the dehumidifier on. The display will turn on and the dehumidifier will start to run. To turn the dehumidifier off press the power button again.

Smart Humidity Mode Button

Smart Humidity Mode

Press the smart humidity mode button once to enter smart humidity mode. In this mode the dehumidifier will default to a target humidity of 55%rh and low fan speed. Once the target of 55%rh has been reached (- 3%rh), the dehumidifier will stop. Every 30 minutes the fan will run and check the humidity level, the dehumidifying indicator will turn off. If the humidity level has increased more than 3% above the target, the compressor will turn on and the dehumidifier will start to run again – the dehumidifying indicator will be solid. If the humidity level is within 3% of the target, the dehumidifier will go back to sleep and check the humidity level in another 30 minutes.

When the humidity level is 15%rh above the set target, the dehumidifier will be in high fan speed; when the humidity level is 15%rh within the target, the dehumidifier will be in low fan speed.

Smart Humidity Mode and Night Mode

Night mode can be set whilst the dehumidifier is in smart humidity mode by pressing the night mode / child lock button once. The fan speed will be reduced to low; the buttons will not bleep when pressed and all lights on the display will turn off (the night mode indicator will turn off 3 seconds later than the rest of the display).

Using the variable humidistat

If you want to set your dehumidifier to reach a target other than 55%rh, continue to press the smart humidity mode button to scroll through the options in the following order: 40, 45, 50, 55, 60, 65, 70, CO. Once you have reached your desired target, the target will show on the display for 5 seconds and then change to the current humidity level.

CO stands for Continuous. With this target the dehumidifier will continue to run and never turn off, regardless of the humidity level.

Once the target humidity level has been reached (- 3%rh), the dehumidifier will stop. Every 30 minutes the fan will run and check the humidity level, the dehumidifying indicator will turn off. If the humidity level has increased more than 3% above the target, the compressor will turn on and the dehumidifier will start to run again – the dehumidifying indicator will be solid. If the humidity level is within 3% of the target, the dehumidifier will go back to sleep and check the humidity level in another 30 minutes.

When the humidity level is 15%rh above the set target, the dehumidifier will be in high fan speed; when the humidity level is 15%rh within the target, the dehumidifier will be in low fan speed.

Air Purification Mode

Hold the smart humidity button down for 2 seconds to enter air purification mode – ‘AP’ will show on the display. In air purification mode the dehumidifier will not dehumidify, it will simply purify the air. This mode is useful during the summer months when dehumidification is generally not required. To remove air purification mode, hold the smart humidity button down for 2 seconds – this will take you back to smart humidity mode.

Please note, if a HEPA filter is installed, the dehumidifier will *always* be purifying the air – it does not specifically need to be in air purification mode.

Smart Laundry Mode

Smart Laundry Mode

Press the smart laundry mode button once to enter smart laundry mode. In this mode the dehumidifier will default to a target humidity of 35%rh and high fan speed. The display will change to ‘35’ for 5 seconds and then back to the current relative humidity level. The dehumidifier will run in smart laundry mode for 6 hours, after 6 hours the dehumidifier will turn off. Press the smart laundry mode button once and the display will show ‘SL’. Press the smart laundry mode button twice to see how much time is left on the timer. ‘06’ means 6 hours, ‘05’ means 5 hours and so on.

If the dehumidifier reaches a humidity level of 32%rh before the 6 hours is up, the compressor will turn off to stop the air from becoming too dry, but the fan will continue to run. The dehumidifying indicator will turn off. If the relative humidity increases to 38%rh the compressor will turn back on. It will do this until the 6-hour timer is up.

Smart Laundry Mode and Night Mode

Night mode can be set whilst the dehumidifier is in smart laundry mode by pressing the night mode / child lock button once. The fan speed will be reduced to low; the buttons will not bleep when pressed and all lights on the display will turn off (the night mode indicator will turn off 3 seconds later than the rest of the display).

Night Mode / Child Lock

Night Mode

Press the night mode / child lock button once to enter night mode. The fan speed will be reduced to low; the buttons will not bleep when pressed and all lights on the display will turn off (the night mode indicator will turn off 3 seconds later than the rest of the display). Press the night mode / child lock button once to view the current humidity level. Press the night mode / child lock button twice to exit night mode.

Child Lock

Hold the night mode / child lock button down for 2 seconds to lock the dehumidifiers control panel – once locked you will not be able to change any settings or turn the dehumidifier off. The dehumidifier will bleep once, and the child lock indicator will light up. To remove child lock, hold the night mode / child lock button down for another 2 seconds.

Dehumidifying Indicator

The dehumidifying indicator will light up solid when the compressor is running, and the dehumidifier is dehumidifying. The indicator will turn off when the dehumidifier is checking the humidity level.

Water Tank Full Indicator

Once the water tank is full, the dehumidifier will continue to run in fan only mode for 3 minutes to blow any excess water off the coils and ensure that when you remove the tank there is no water left that could drip out of the spout. The water tank full indicator will then light up solid and bleep five times. The dehumidifier will stop running until the water tank has been emptied and inserted back in place. Once the water tank has been emptied and inserted back in place, the dehumidifier will continue to run in the previous mode.

Air Purification Indicator

The air purification indicator will light up solid when the dehumidifier is in air purification (AP) mode only.

Child Lock Indicator

The child lock indicator will light up solid when child lock has been enabled.

Water Tank

The dehumidifier can be used to collect water in one of two ways: via the water tank or via continuous drainage. For general use in the home customers tend to use the water tank to collect water. For more information on how to use continuous drainage, see pages 13 and 14.

When the water tank is full and requires emptying, the dehumidifier will turn off, bleep five times and the water tank full indicator will light up solid. To empty the water tank, simply pull the water tank out from the dehumidifier and empty the water. The handle can be used to make it easier to carry the water tank. Use the pouring holes on the left or right corner of the water tank to empty the water (the water tank lid does not need to be removed).

The water collected can be used to water non-edible plants only – do not consume.

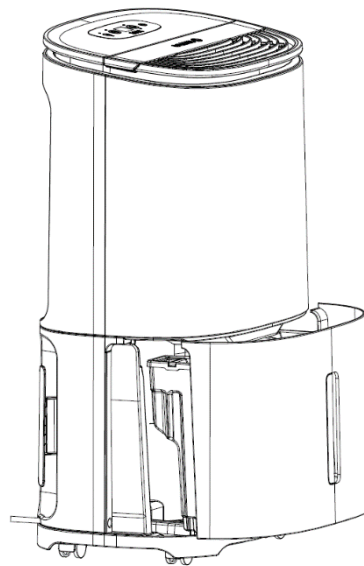

Cleaning the water tank

If you want to clean the inside of the water tank, the water tank lid needs to be removed – simply lift the lid off the water tank.

Water tank float

Located inside the water tank is a float. It is essential that the float is NOT removed from the water tank. The float measures the level of water in the water tank and triggers the sensor to turn the dehumidifier off when the water tank is full. If the float is removed from the water tank, the dehumidifier will not run.

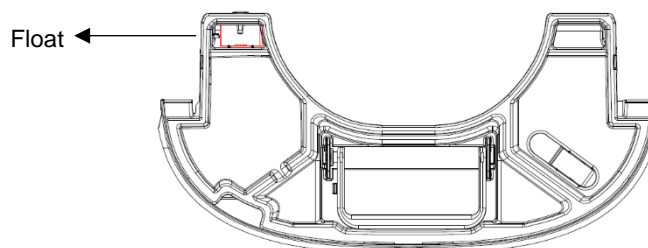

How often will I need to empty the water tank?

Customers often ask us how often they will need to empty their dehumidifiers water tank; however, the answer is different for everyone. How much water your dehumidifier collects will depend on several factors including: the humidity level, temperature, application, dehumidifier location, number of people, amount of moisture added to the environment and so on. In general, when customers first purchase a dehumidifier, they tend to see the dehumidifier run constantly and collect a lot of water. This is the dehumidifier removing all the excess water in the environment. After the dehumidifier has removed this excess moisture, it will settle down and collect less – this can take a couple of days, or it could take 4 weeks, it is individual for each situation. If your dehumidifier does not collect lots of water to begin with, it does not mean it is faulty, it could mean your humidity level is already low, or you need to change the settings. If you have any questions, feel free to call us on 01483 234900.

Continuous Drainage

**Hose not included. For more information see page 8.*

Continuous drainage can be used to drain water from the dehumidifier without having to empty the water tank. This is ideal for customers who wish to leave their dehumidifier unattended in garages or second homes.

The right-angle adaptor required can be found in the lid of the water tank. This adaptor has been designed to fit a standard garden hose (ID: 12.5mm). Make sure the hose runs downwards with no kinks, bends or blockages to allow the water to drain out via gravity.

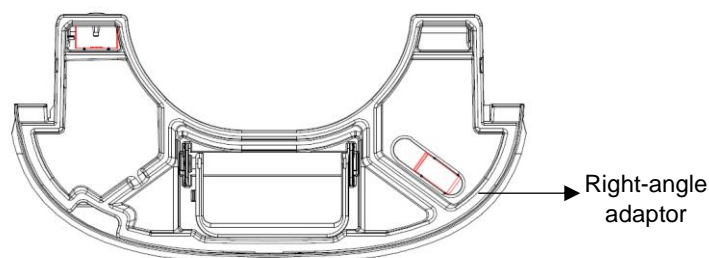

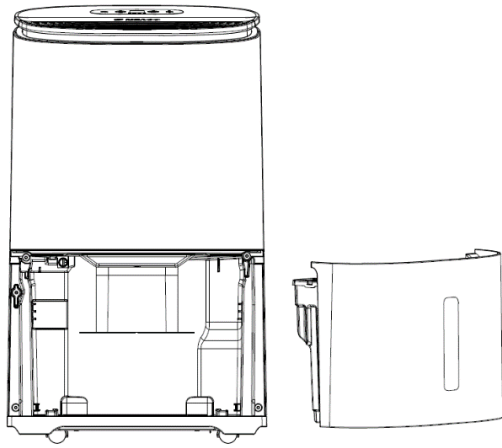

Step 1: Remove the water tank.

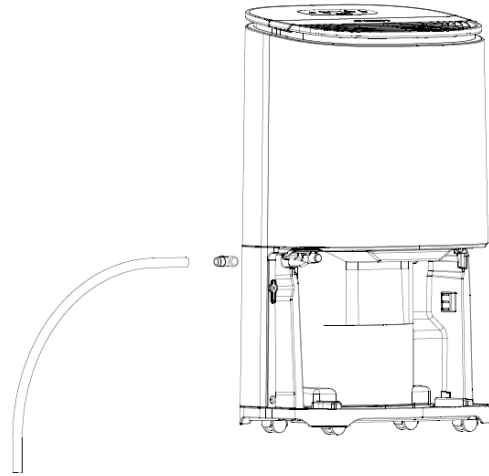

Step 2: Remove the right-angle adaptor from the water tank lid and push it onto the spout. The spout is where water drips out of the dehumidifier and is located on the left-hand side.

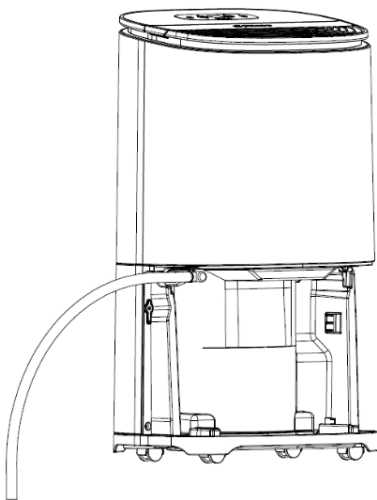

Step 3: Attach the hose to the spout.

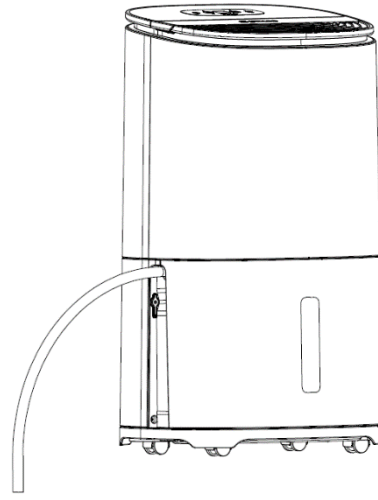

Step 4: Insert the water tank back into the dehumidifier.

Cleaning

Always turn off the power and disconnect the main cable before performing maintenance procedures.

- Inspect the electrical cord for damage at regular intervals.

Cleaning the exterior

- Clean the exterior with a soft, dry cloth. If the dehumidifier is extremely dirty, use a mild cleaning agent or a slightly damp cloth. Never spray the device with water.

Cleaning the dust filter

The dust filter is a life-long filter and therefore should not need to be replaced (other than for wear and tear reasons). When used regularly, the filter may become clogged with dust and dirt particles. The filter must be cleaned a **minimum of every two weeks** (not doing so could invalidate the units' warranty). Please follow the steps below.

1. Remove the dust filter from the dehumidifier by sliding the filter case to the left, away from the dehumidifier. The dust filter is built into the filter case and cannot be removed – you may have to remove the HEPA filter to access the dust filter.
2. Clean the dust filter with the end of a Hoover or soapy water no hotter than 40°C. Rinse and dry completely before inserting back into the dehumidifier.

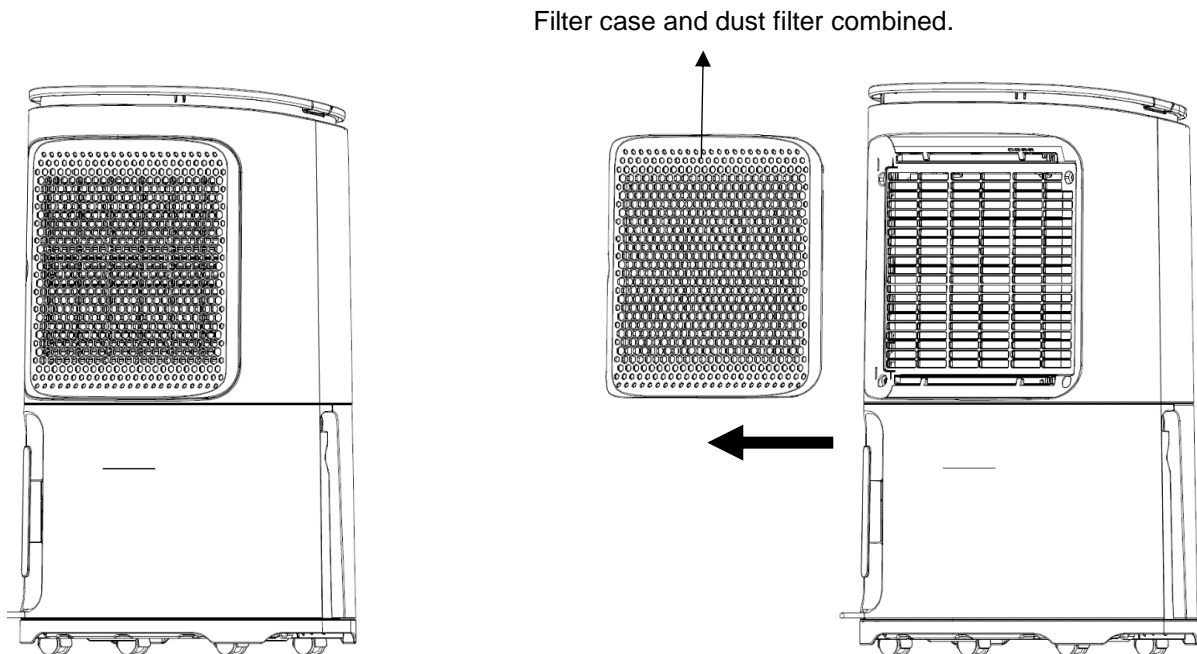

Replacing the HEPA filter

The dehumidifier comes with a H13 HEPA filter. This HEPA filter can be inserted into the dehumidifier to enable air purification, however this is optional - the dehumidifier can be used without the HEPA filter, this means it will dehumidify the air only and not purify it.

- The HEPA filter is not life-long and must be replaced when the colour changes from white to grey (it depends on the environment the dehumidifier is being used in but the HEPA filter will need replacing roughly every 3 months).
- The HEPA filter can be hoovered every so often to remove any dust or dirt.
- To insert/replace the HEPA filter place it inside the combined filter case and dust filter, then slide the combined filter case and dust filter into the dehumidifier.
- Replacement HEPA filters can be purchased from www.meaco.com.

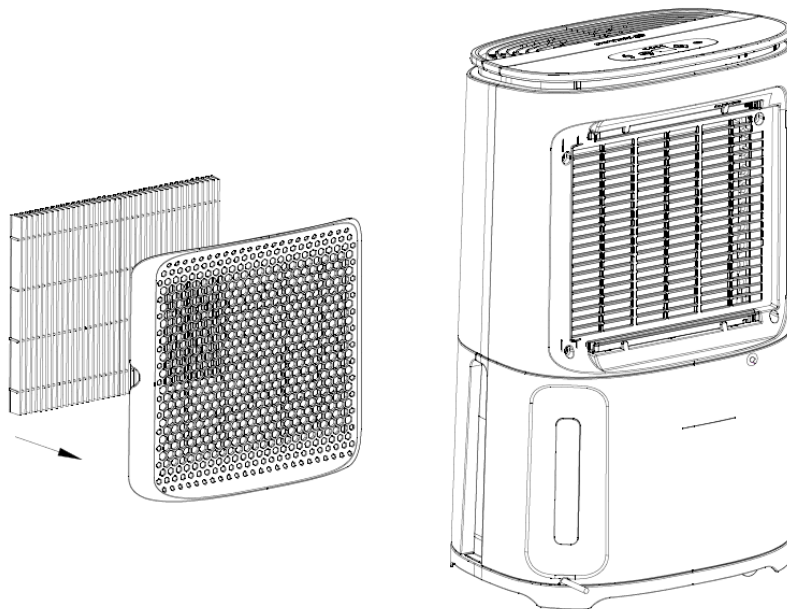

Storage

If the dehumidifier will not be used for a long period of time, take the following steps:

1. Remove the plug from the socket and empty the water tank. Allow the water tank and the dehumidifier to dry completely, this can take a couple of days.
2. Use the cable tidy on the back of the dehumidifier to wrap the cable away.
3. Clean the filter and store the device in a dust-free location away from direct sunlight, preferably covered with a sheet of plastic.

Specifications

	18L
Dimensions (HWD)	562 x 376 x 232 mm
Weight	15kg
Noise Level	38 and 40dB(A)
Nominal Power Consumption	250 watts
Air Flow	Low Fan Speed: 145m ³ /h High Fan Speed: 160m ³ /h
Auto-restart	Yes
Filter Type	Dust Filter (and optional HEPA filter)
Power Supply	220-240V, 50Hz
Fan Speeds	2 (automated depending on humidity level)
Operating Temperatures	+5° to +35°C
Refrigerant	R290 / 65g
Water Tank Size	4.8l
Variable Humidistat	Yes between 40%rh and 70%rh

Trouble Shooting

Trouble	Solution
The dehumidifying indicator is flashing	The dehumidifier is checking the humidity level to see if it has risen above your target – see pages 9 and 10 for more information.
The buttons no longer beep when pressed	The dehumidifier is in night mode. To remove night mode, press the night mode button once.
There are no lights on the display apart from the night mode indicator	The dehumidifier is in night mode. To remove night mode, press the night mode button once.
‘AP’ is showing on the display.	AP stands for ‘Air Purification Mode’. See page 10 for more information.
‘SL’ is showing on the display	The dehumidifier is in smart laundry mode. See page 10 for more information.
E1 flashes every 30 seconds on the display.	Please contact Meaco
E2 flashes every 30 seconds on the display.	Please contact Meaco
L3 slowly flashes on the display.	The environment the dehumidifier is being used in is too warm. Make sure the dehumidifier is being used in 40°C or less.
L4 slowly flashes on the display.	The environment the dehumidifier is being used in is too cold. Make sure the dehumidifier is being used in 2°C or more.
The dehumidifier does not operate	Make sure the dehumidifier is plugged in to the mains and press the power button once.
The dehumidifier does not dehumidify / collects little water.	The temperature is either too cold or too warm, make sure the dehumidifier is being used in an environment between 5°C and 35°C.
	The humidity level is already very low – below 45%rh the dehumidifier will not collect much water as there is not enough moisture in the environment.

<p>The dehumidifier does not dehumidify / collects little water</p>	<p>The target humidity level is higher than the actual humidity level. Use the smart humidity mode button to reduce the target humidity level.</p> <hr/> <p>Clean the dust filter and/or replace the HEPA filter. If these are dirty, they will block the airflow and prevent the dehumidifier from dehumidifying.</p> <hr/> <p>The dehumidifier is in AP mode. See page 10 for more information.</p>
<p>The dehumidifier works but reduces the humidity level insufficiently/there is little water in the water tank</p>	<p>The application is too large. This dehumidifier can be used to dry up to a 5-bedroom house.</p> <hr/> <p>Make sure all windows and external doors are shut to reduce the ventilation.</p> <hr/> <p>Clean the dust filter and/or replace the HEPA filter. If these are dirty, they will block the airflow and prevent the dehumidifier from dehumidifying.</p>
<p>The windows were clear and now the condensation has returned.</p>	<p>This is because the outside temperature has dropped, and the windows are now colder. Use the dehumidifier on a lower target setting and run it 24 hours a day.</p>
<p>The condensation on my windows will not go, even when the dehumidifier is in CO mode.</p>	<p>The surface temperature of the windows is too low for a dehumidifier to prevent condensation. This is common with single glazed windows and when the air temperature outside drops below freezing. Keeping running the dehumidifier in CO mode 24 hours a day, when the air temperature outside increases the windows should clear of condensation.</p>
<p>The dehumidifier is blowing out warm air</p>	<p>The dried air is passed over heating coils before it is blown into the room as part of the dehumidification process. This is normal.</p>
<p>The dehumidifier is blowing out cool air</p>	<p>The dehumidifier does not cool the air, the air may feel cooler because it is moving in the same way as the air from a fan in the summer feels cooler. This is normal.</p>
<p>The dehumidifier is noisy</p>	<p>Clean the dust filter and/or replace the HEPA filter. Make sure the dehumidifier is placed on a flat surface. A dehumidifier will be noisier on wooden floors than carpet</p>

Warranty

There is a five-year warranty on your dehumidifier from the date of purchase, held with Costco. Keep hold of your receipt and contact Costco should your dehumidifier develop a fault during the warranty period.

Please register your purchase at <https://meaco.com/warranty-register> - as a thank you, you will be entered into our monthly free prize draw to help support the David Shepard Wildlife Foundation. Registering also allows us to keep you update with any important developments concerning your product.

To register your warranty, you will need the product's serial number. This can be found on the label on the side of the dehumidifier.

To prevent unnecessary expenses, we recommend that you always carefully read the user's manual first. If this does not provide a solution, please call Meaco and we will be happy to help.

This dehumidifier has been imported into the UK by:

*Meaco (UK) Limited
Meaco House
Parklands, Railton Road
Guildford
GU2 9JX*

*Telephone: 01483 234900
Email: customerservice@meaco.com
Website: www.meaco.com*

Date of purchase: __ / __ / ____

Purchased from: Costco

Serial Number: _____

The marking below indicates that this product should not be disposed with other household wastes throughout the UK. To prevent possible harm to the environment or human health from uncontrolled waste disposal, recycle it responsibly to promote the sustainable reuse of material resources. To return your used device, please use the return and collection systems or contact the retailer where the product was purchased. They can take this product for environmentally safe recycling.

