

ASSEMBLY INSTRUCTIONS

BAR CABINET

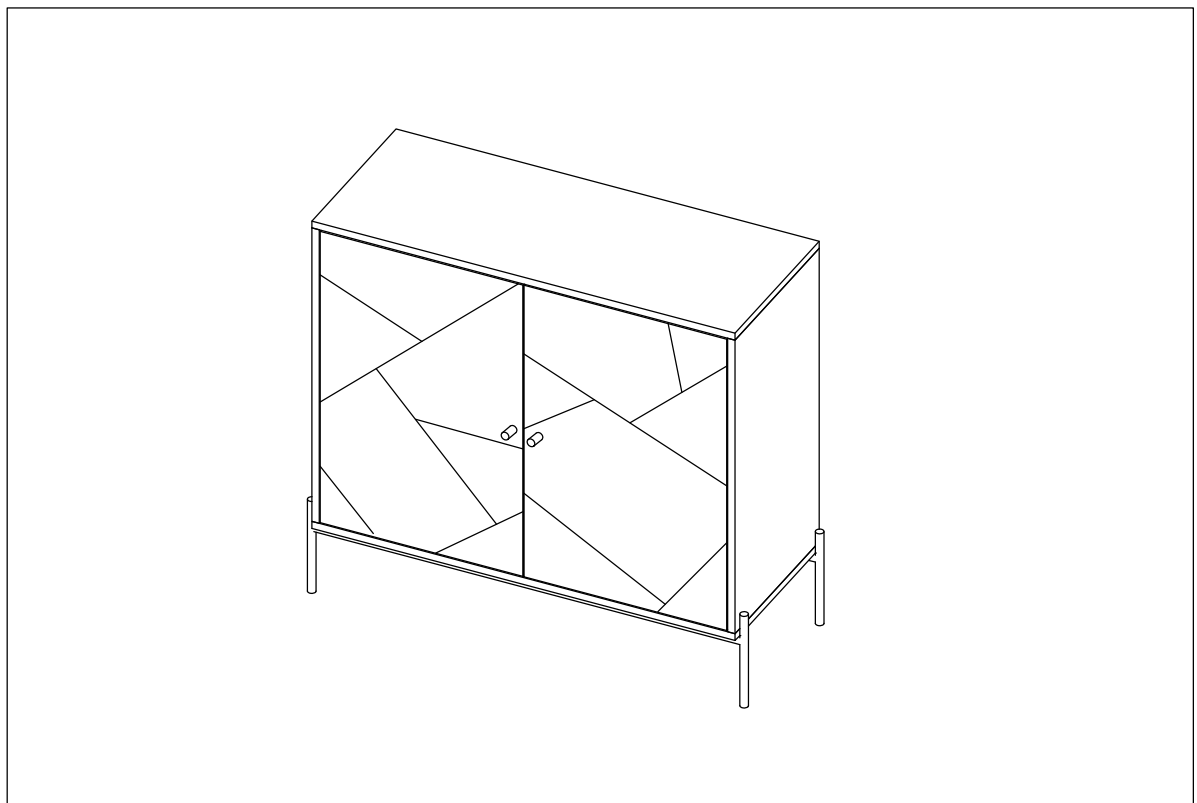

5059413403170

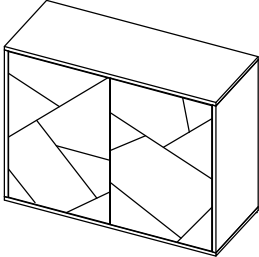
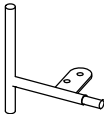

Component List

Label	Picture	Description	Qty
A		Bar Cabinet	1
B		Leg	4

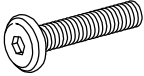

Hardware List

Label	Picture	Description	Qty
H1		Large Allen Bolt M6x16mm	8
H2		Flat Washer M8x16 mm	8
H3		Small Allen Bolt M6x10mm	4

Tool List

Label	Picture	Description	Qty
T1		Allen Key 4mm	1

Assembly Prep Before Beginning

- * Save all packing until finished. 
- * Read Instructions, cover to cover. 
- * Have 2 adults on hand for assembly. 

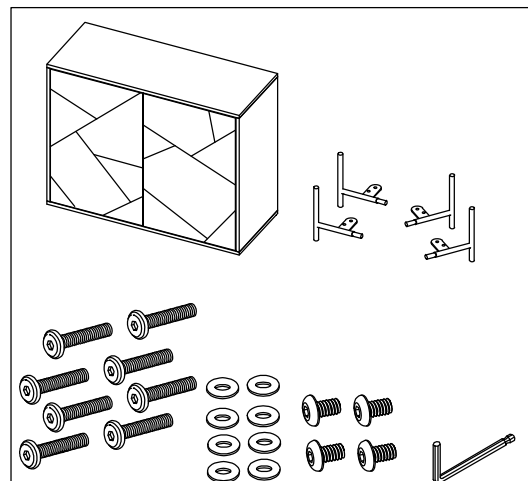

Assembly Steps

Step 1

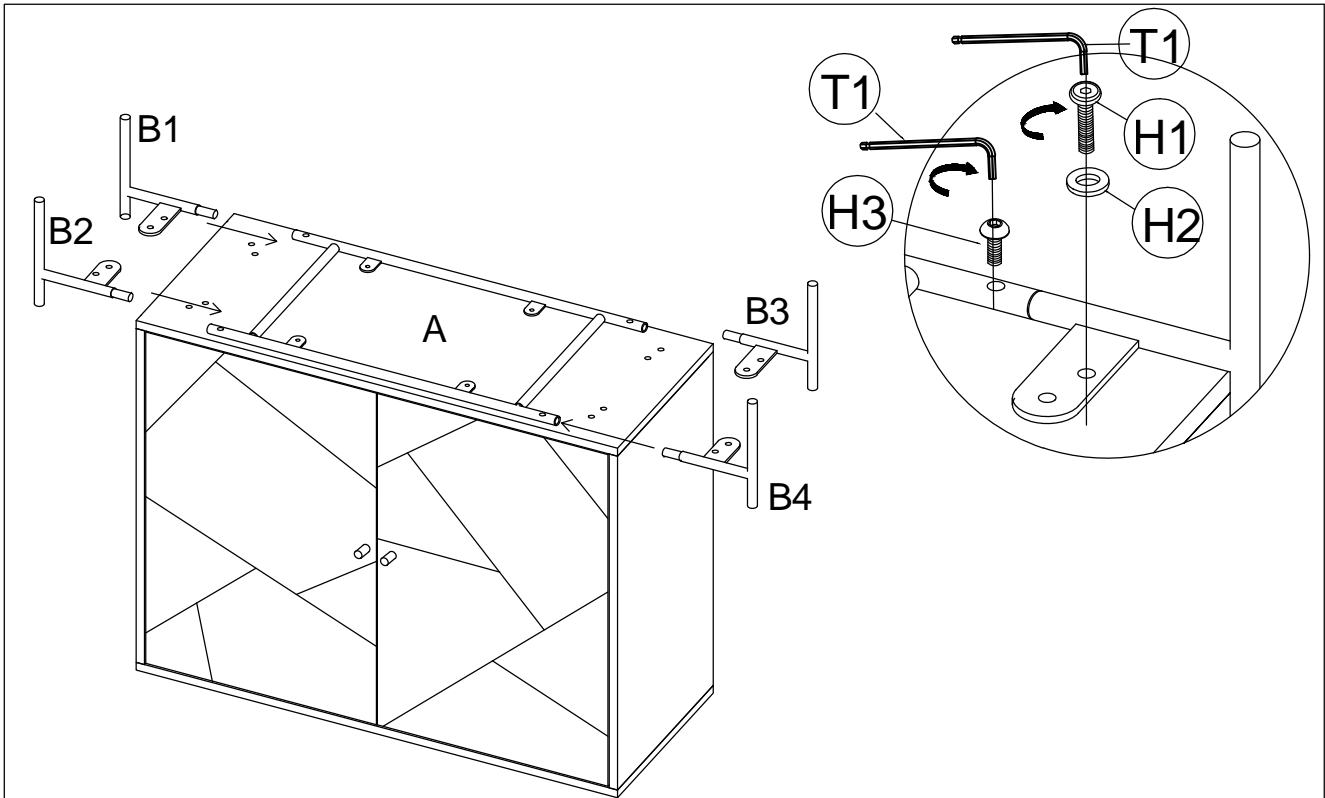

Careful : Extremely heavy product.

Place Bar Cabinet (A) upside down on a padded non-damaging surface. Matching the marking label on legs and cabinet, Gently insert the Leg (B) onto the pre-fixed metal rod underneath the Bar Cabinet (A) and secure using Large Allen Bolt (H2) and Flat Washer (H1) as illustrated above. Do not fully tighten connection unless the Small Allen Bolt (H3) is aligned and tighten. Fully tighten all connection using Allen Key (T1). Repeat the same step to assemble other legs.

Step 2

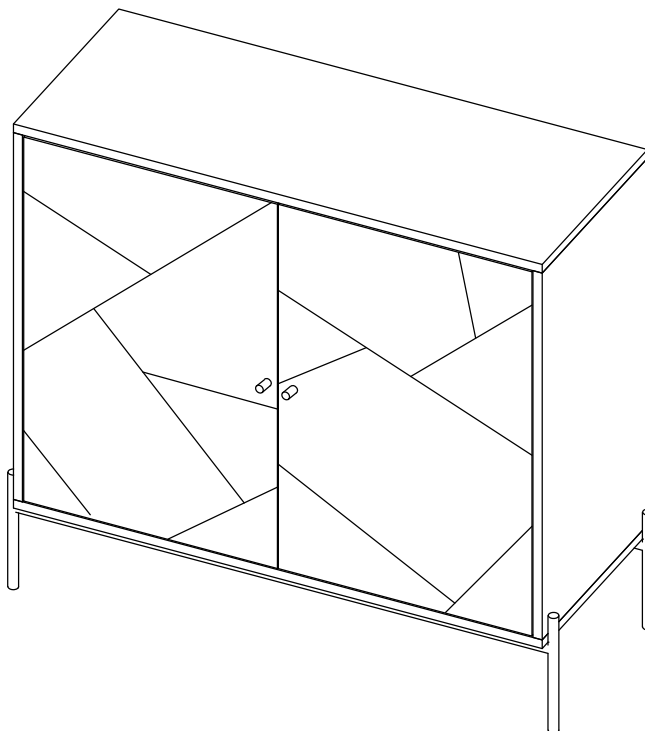

Turn the piece upright. Product assembly is now complete and product is ready to use.

Hinge Adjustment Guide

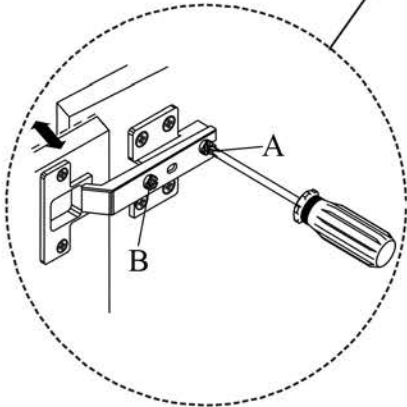
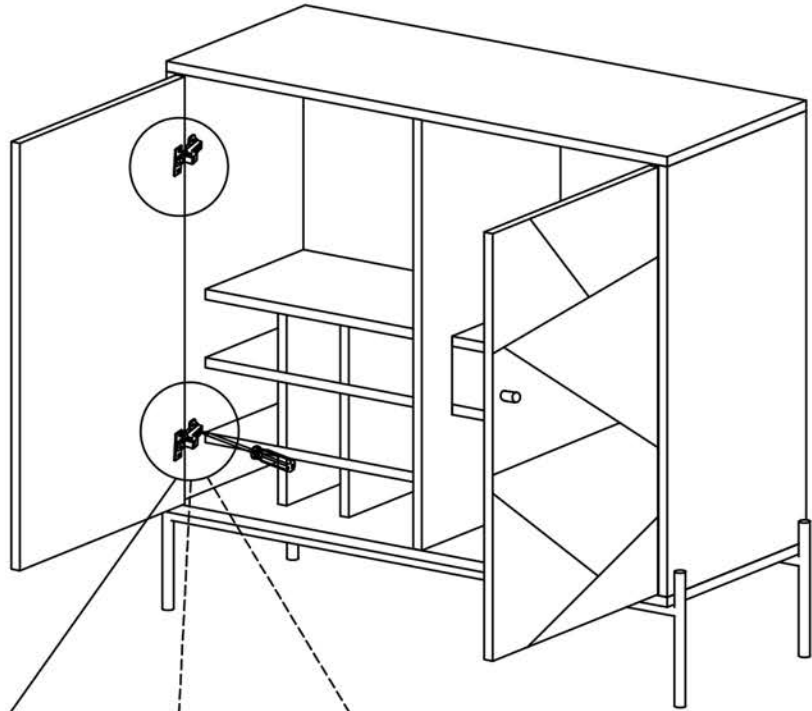

Side to Side Adjustment
loosen screw A, adjust gap with screw B and re-tighten Screw A.

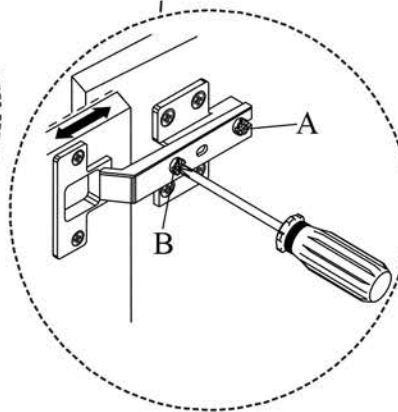

Depth Adjustment
loosen screw A, push hinge arm forwards or backwards, re-tighten screw A and secure Screw B with a 1/4 turn clockwise.

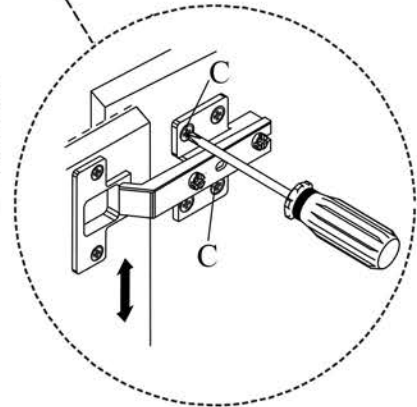



Height Adjustment
loosen screw C, adjust door height and re-tighten screw C.

* The doors can be adjusted in all 3 directions to create an even fit between doors on this cabinet. Follow the appropriate directions above to adjust door(s) as necessary.

With minimum two people, carefully turn the product in the upright position. Place the piece on required location and adjust the hinges following above hinge adjustment guide.

ANTI-TOPPLE KIT INSTRUCTION

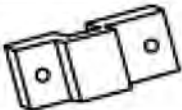
YOU MUST SECURE YOUR FURNITURE TO THE WALL IN ACCORDANCE WITH THE FOLLOWING INSTRUCTIONS, TO PREVENT INJURY/PROPERTY DAMAGE FROM UNEXPECTED TIPPING FURNITURE.

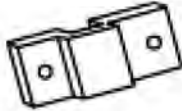
	PART	NAME	IMAGE	QTY
<p>IMPORTANT: Screws or wall fixing into the wall is not included. You will need to select a suitable screw or fixing appropriate for the type of walls you have. If you are unsure about what type of fixing you require, you must seek advice of a professional who has experience of fitting this type of item. The anti-topple device must not be modified or altered in any way.</p>	A	Wall Bracket		2
	B	Cable Tie		2
	C	Pre-fixed bracket not in hardware bag		2

To secure Furniture to wall:

1. Position your furniture in the room, then place Wall bracket (A) on wall near pre-fixed Wall Bracket(C) pre-fixed to back of furniture, and mark position of (A) with a pencil.
2. Move furniture aside and secure Wall bracket (A) into wall using suitable wall fixings - Screws or wall fixing not included. Seek professional advice if unsure of fixing.
3. Feed small end of Cable tie (B) down through fixed Wall bracket (A).
4. Repeat the same step to secure other Bracket (A), then reposition furniture in place.
5. Loop cable tie through pre-fixed Wall Bracket (C) and connect the cable tie. The cable tie should have both wall Bracket (A) and product connected.
6. Finish position of your furniture if required, then pull tight the Cable Tie (B).

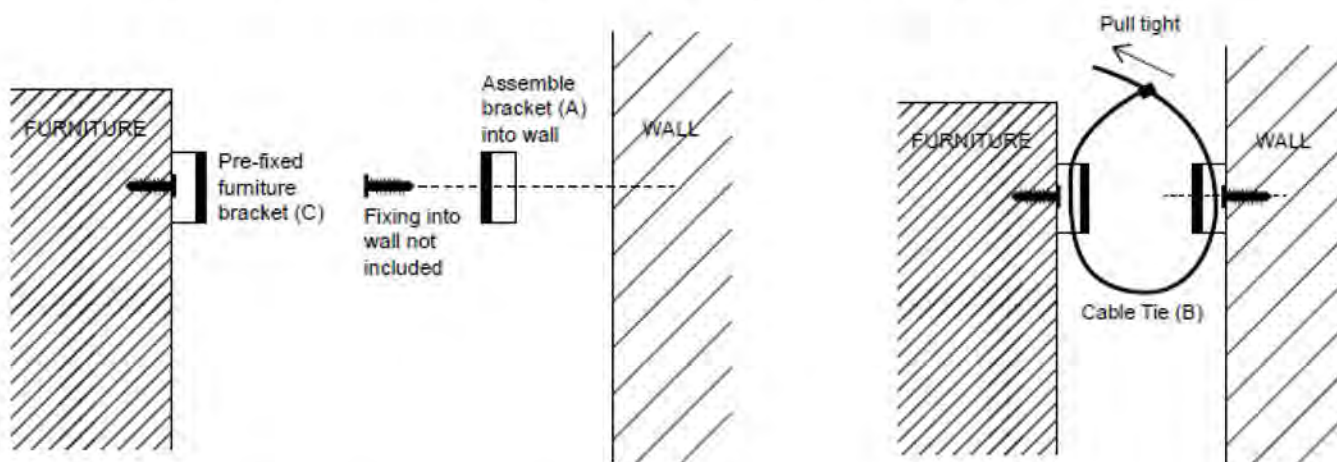

Your furniture should now be protected from toppling over.