

IMPORTANT: PLEASE REGISTER YOUR STONE GARDEN LIFESTYLE PRODUCT BEFORE ASSEMBLY

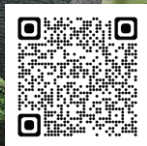

Affix Serial Number
HERE

Using the unique serial number, simply register your product using the QR code above.

Customer Service: Call: +44 (0) 1889 272 056

PLEASE READ THIS DOCUMENT FULLY PRIOR TO STARTING ASSEMBLY PROCEDURE

The objective of this instruction is to illustrate the recommended assembly sequence for this product, any deviation from this will be the sole responsibility of whoever carries out the assembly.

IMPORTANT: IT IS ADVISABLE THAT THE PRODUCT IS ASSEMBLED AT, OR AS CLOSE AS POSSIBLE TO WHERE IT WILL BE FINALLY LOCATED

Ensure there is adequate clearance where the product is to be located:

Exterior dimensions including overhang (W x D x H)	1800 x 1840 x 2140mm
Footprint dimensions (W x D)	1700 x 1700mm
Clearance required for door to open (W x H)	Doors open outwards 1454 x 1820mm

TWO PERSON ASSEMBLY

Most procedures will not require two people but it may be easier to have assistance.



PERSONAL PROTECTION EQUIPMENT

We advise appropriate personal protective equipment is worn during assembly including eye protection and gloves.



Eye Protection

Gloves

CARING FOR YOUR PRODUCT

Your **Stone Garden Lifestyle** product is designed to stand the test of time, which is why we're happy to offer a 25 year warranty on our products. With zero maintenance required, simply assemble your **Stone Garden Lifestyle** product and enjoy putting it to great use in your garden.

Periodically, you might want to give your product a clean, these simple care tips are not essential to the performance of your product:

- Remove surface dirt with plain water using a jet wash or sponge, the coating on our products will ensure dirt or mud simply wipes away.
- Periodically clear the lid of fallen leaves.
- If your product has guttering, remove leaves and garden debris as you would on your home.

PRODUCT REGISTRATION

IMPORTANT: Prior to assembly, please ensure you have registered your **Stone Garden Lifestyle** product using the unique serial number found on the cover of this document, please visit <https://bit.ly/StoneGardenWarranty> to register your product and access the 25 year warranty and online support.

GROUND ANCHOR KIT

A Ground Anchor Kit is supplied, this is to secure the product to a solid concrete base, the shed has x4 clamp plates in each corner.

WE STRONGLY ADVISE THAT THE SHED IS ANCHORED USING THIS KIT

The diagram illustrates the typical fixing method, once the shed is assembled, access the clamp brackets by removing the appropriate floor panel and secure as required.

GROUND ANCHOR KIT

Part Ref: FK8
M8 x 50mm Coach Screw
Qty: x8



Part Ref: FK7
Expansion Plug
Qty: x8

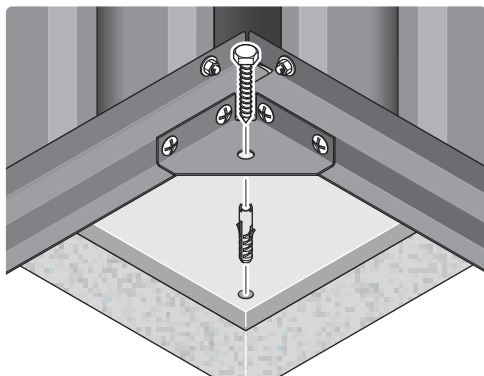

Assembly Guide

ENSURE ALL ITEMS LISTED ARE PRESENT PRIOR TO STARTING ASSEMBLY PROCEDURE
SCALE OF ITEMS WILL VARY TO AID VISUAL IDENTIFICATION

Part Ref: 0215-01
Qty: x2

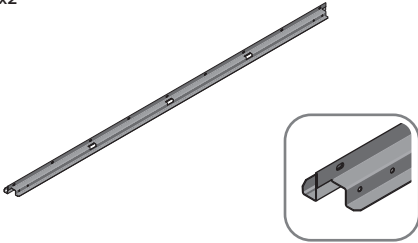

Part Ref: 0212-03
Qty: x3

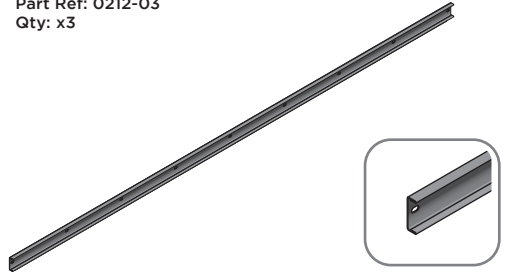

Part Ref: 0212-01
Qty: x2

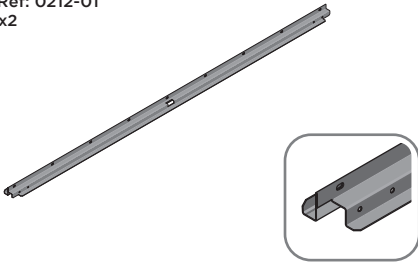

Part Ref: 0205-74
Qty: x1

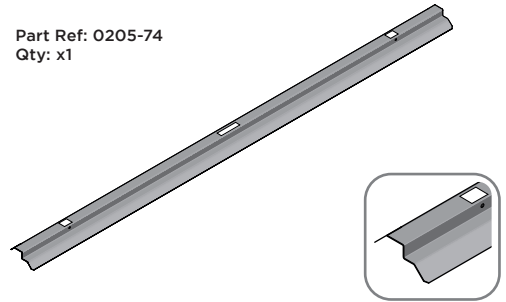

Part Ref: 0205-13 (1850 x 425mm)
Qty: x3

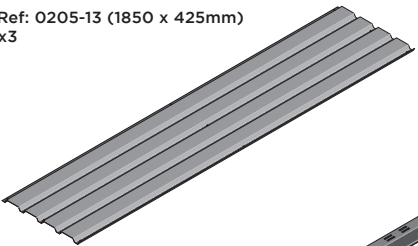

Part Ref: 0205-12 (1850 x 625mm)
Qty: x6

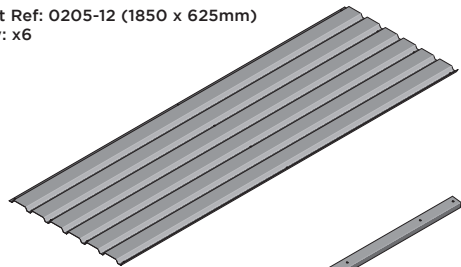

Part Ref: 0205-38-01
Qty: x2



Part Ref: 0215-04
Qty: x1

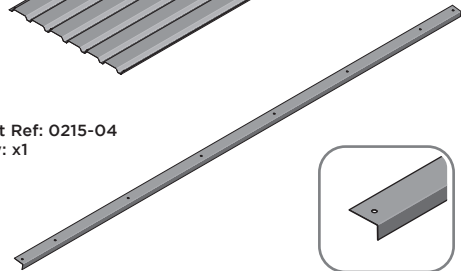

Part Ref: 0205-38-02
Qty: x2

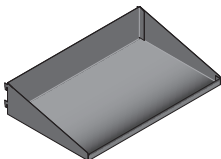

Part Ref: 0205-39
Qty: x4



Assembly Guide

ENSURE ALL ITEMS LISTED ARE PRESENT PRIOR TO STARTING ASSEMBLY PROCEDURE

SCALE OF ITEMS WILL VARY TO AID VISUAL IDENTIFICATION

Part Ref: 0205-14 (1885mm Long)
Qty: x2

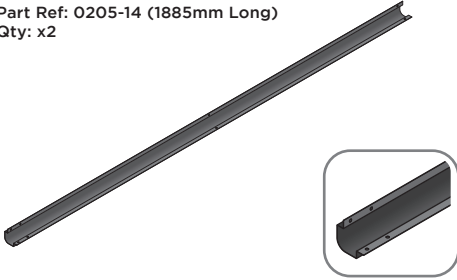

Part Ref: 0215-02
Qty: x4

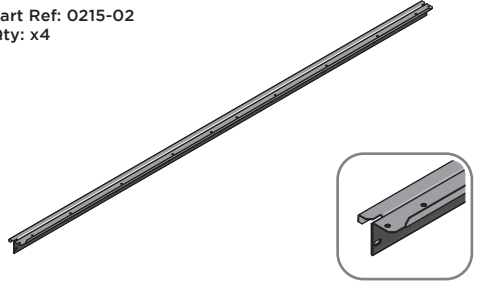

Part Ref: 0205-15 (2100mm Long)
Qty: x2

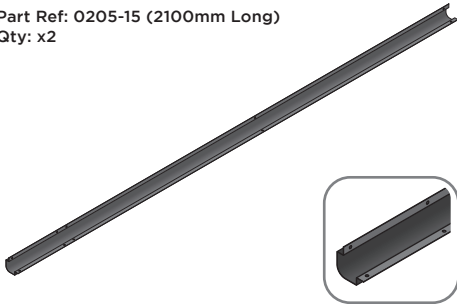

Part Ref: 0212-13
Qty: x2



Part Ref: 0212-14
Qty: x2

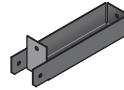

Part Ref: 0205-16 (R/H)
Qty: x1

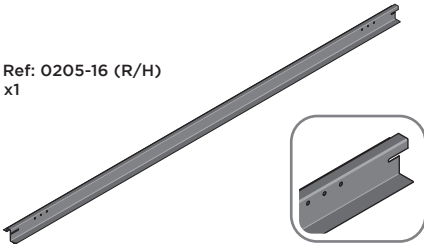

Part Ref: 0215-06
Qty: x2



Part Ref: 0205-17 (L/H)
Qty: x1

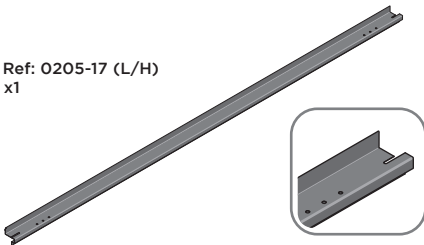

Part Ref: 0212-05 (1800 x 625mm)
Qty: x4

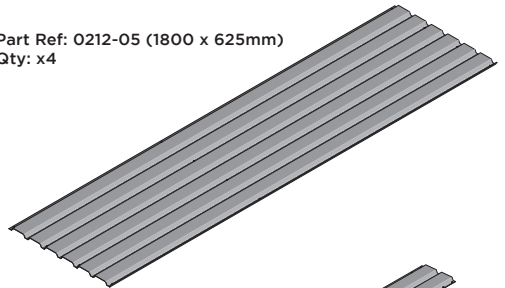

Part Ref: 0212-06 (1800 x 215mm)
Qty: x1

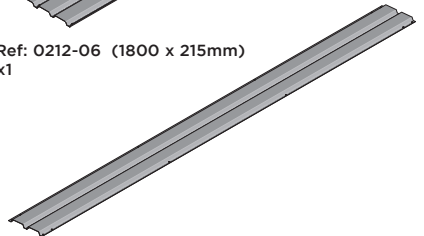

Assembly Guide

ENSURE ALL ITEMS LISTED ARE PRESENT PRIOR TO STARTING ASSEMBLY PROCEDURE
SCALE OF ITEMS WILL VARY TO AID VISUAL IDENTIFICATION

Part Ref: 0212-07
Qty: x2

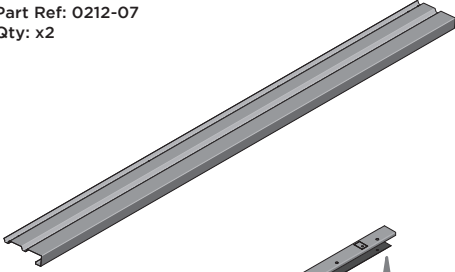

Part Ref: 0215-11
Qty: x1

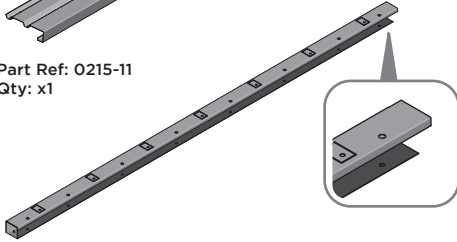

Part Ref: 0212-11
Qty: x1

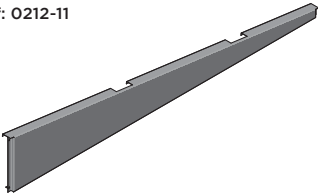

Part Ref: 0212-12
Qty: x1

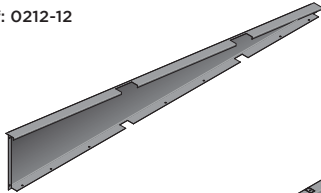

Part Ref: 0215-12
Qty: x1

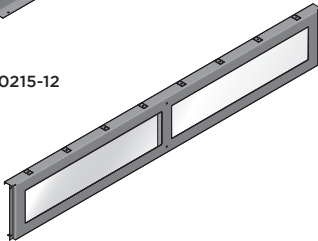

Part Ref: 0205-44
Qty: x1

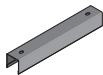

Part Ref: 0215-03
Qty: x1

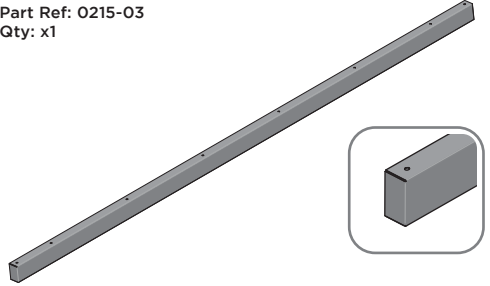

Part Ref: 0215-05
Qty: x1

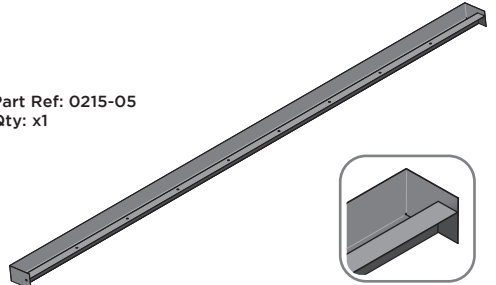

Part Ref: 0205-36 (R/H)
Qty: x1

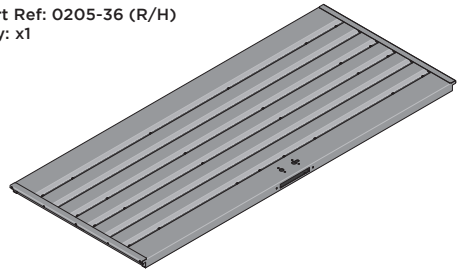

Part Ref: 0205-37 (L/H)
Qty: x1

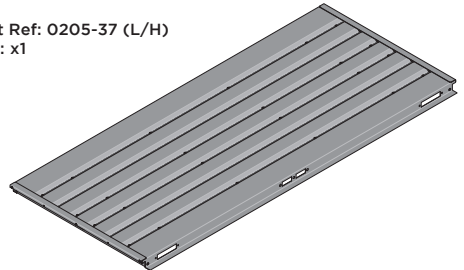

Assembly Guide

ENSURE ALL ITEMS LISTED ARE PRESENT PRIOR TO STARTING ASSEMBLY PROCEDURE

SCALE OF ITEMS WILL VARY TO AID VISUAL IDENTIFICATION

Part Ref: 0203-03
Qty: x4



Part Ref: 0205-57
Qty: x4



Part Ref: 0203-15
Qty: x4



Part Ref: 0205-63
Qty: x2

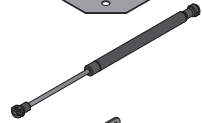

Part Ref: 0203-28 (L/H Assembly)
Qty: x2



Part Ref: 0205-66
Qty: x2



Part Ref: 0203-27 (R/H Assembly)
Qty: x2



Part Ref: 0205-68
Qty: x4



Part Ref: 0203-32 (Assembly)
Qty: x1

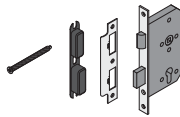

Part Ref: 0205-52
Qty: x1



Part Ref: 0205-53
Qty: x1



Part Ref: 0203-33 (Assembly)
Qty: x1

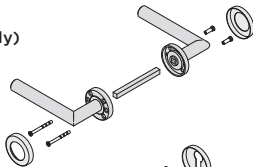

Part Ref: 0205-57
Qty: x4



Part Ref: 0203-34 (Assembly)
Qty: x1

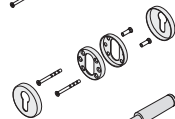

Part Ref: FK1
M4 x 10mm Roofing Bolt
This will be Pozi or Slotted
Qty: x235



Part Ref: 0203-35
Qty: x2

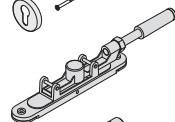

Part Ref: FK2
No.8 x 13mm Eco Fix
Qty: x32



Part Ref: 0203-36
Qty: x1



Part Ref: FK3
M4 x 12mm C'Sunk Pozi Pan
Qty: x31



Part Ref: 0203-37
Qty: x4

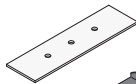

Part Ref: FK4
M4 Rubber Washer
Qty: x34



Part Ref: 0203-39
Qty: x4

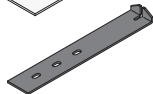

Part Ref: FK5
M4 Serrated Flange Nut
Qty: x261



Part Ref: 0203-40
Qty: x4



Part Ref: FK6
M8 Serrated Flange Nut
Qty: x5



Part Ref: 0203-41
Qty: x1

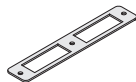

Part Ref: FK7
Expansion Plug
Qty: x8



Part Ref: FK8
M8 x 50mm Coach Screw
Qty: x8

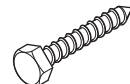

Assembly Guide

ASSEMBLY STAGE 1

LOCATE AND SECURE A CORNER BRACE 0203-03 AT EACH LOCATION INDICATED.

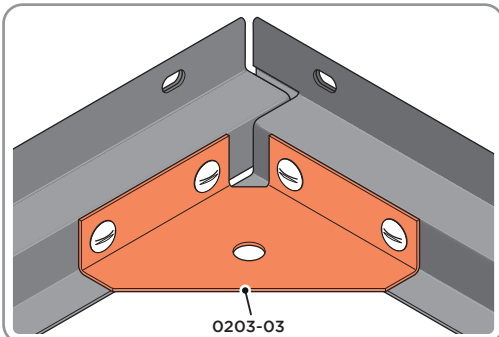
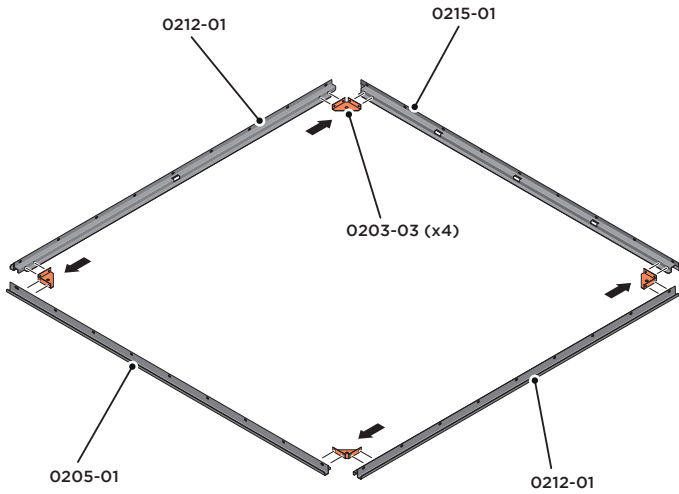

SECURE EACH CORNER BRACE 0203-03 AS SHOWN ABOVE.

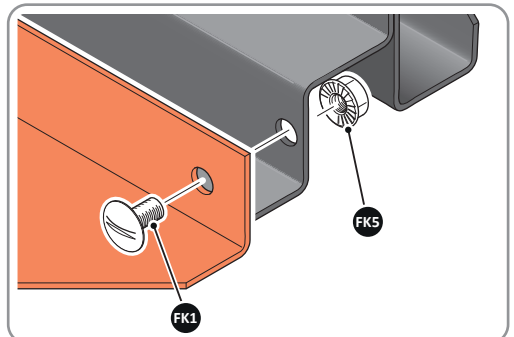

PLEASE NOTE: SECTION VIEW OF TYPICAL FIXING METHOD

Assembly Guide

ASSEMBLY STAGE 2

LOCATE AND LOOSELY ATTACH WALL PANEL 0205-12 (1850 x 625mm).

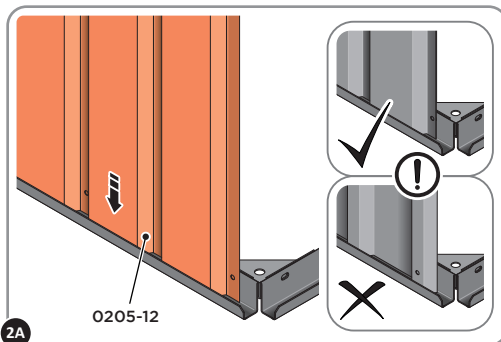
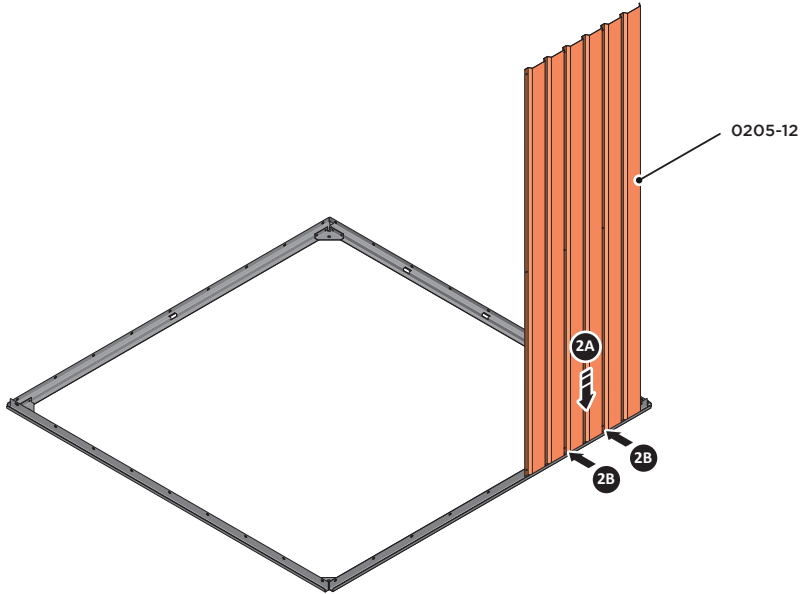

2A LOCATE WALL PANEL 0205-12 INTO POSITION AS SHOWN ABOVE.
IMPORTANT: ENSURE PANEL IS IN THE CORRECT ORIENTATION.

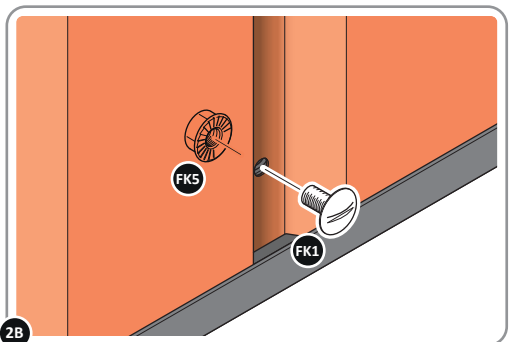

2B LOOSELY ATTACH WALL PANEL AT x2 LOCATIONS INDICATED ONLY.
IMPORTANT: DO NOT SECURE ANY FIXING POINTS OTHER THAN THOSE INDICATED.

Assembly Guide

ASSEMBLY STAGE 3

LOCATE AND LOOSELY ATTACH CORNER POST 0205-15 (2100mm).

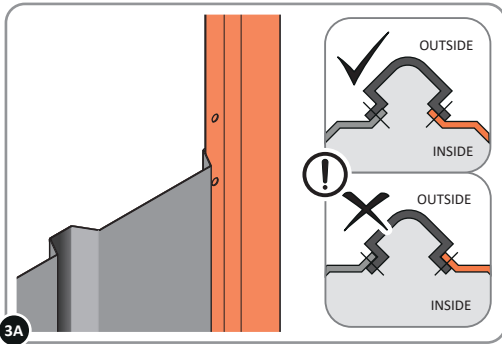

3A
LOCATE FIRST WALL PANEL 0205-12 (1850 x 625mm) AS SHOWN ABOVE.
IMPORTANT: ENSURE PANEL IS IN THE CORRECT ORIENTATION.

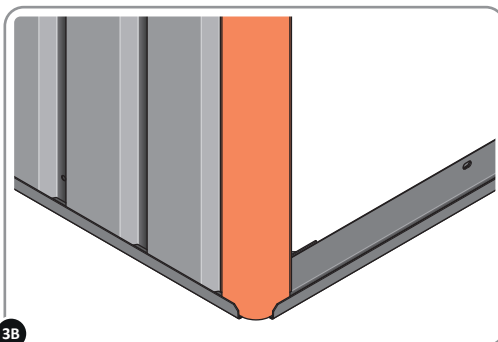
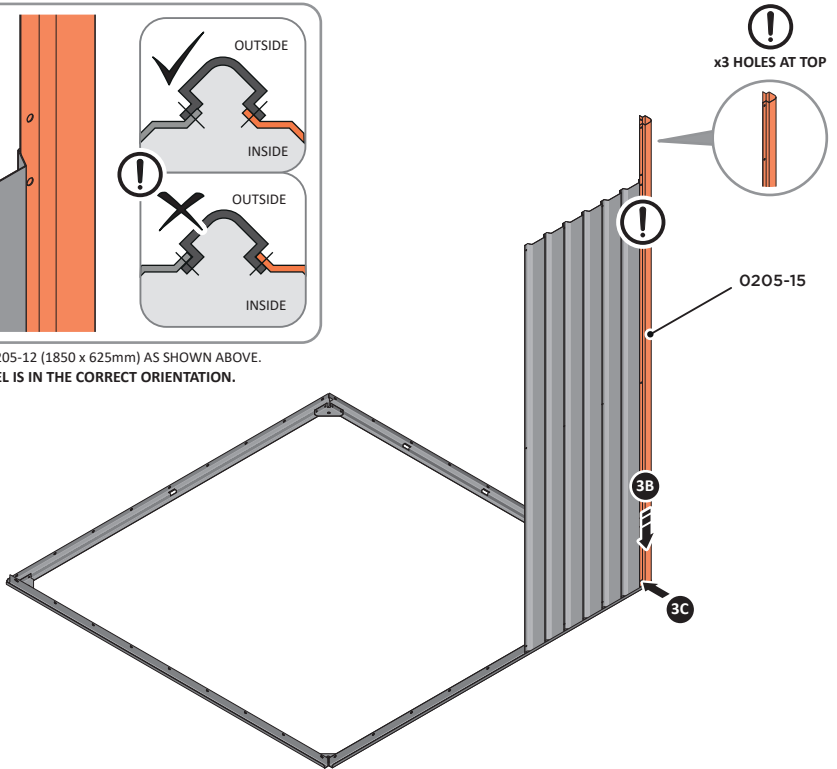

3B
LOCATE CORNER POST 0205-15 (2100mm) AS SHOWN ABOVE.

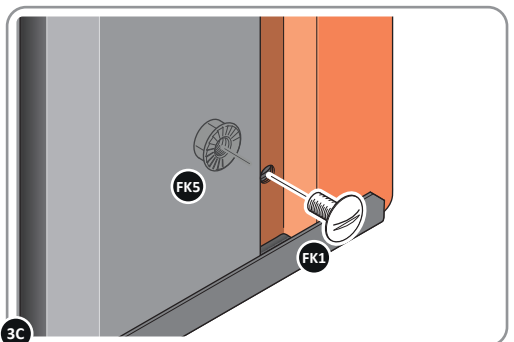

3C
LOOSELY ATTACH CORNER POST AT LOCATION INDICATED ONLY.
IMPORTANT: DO NOT SECURE AT UPPER FIXING POINT AT THIS STAGE.

Assembly Guide

ASSEMBLY STAGE 4

LOCATE AND LOOSELY ATTACH MID CENTRE BRACE 0212-03.

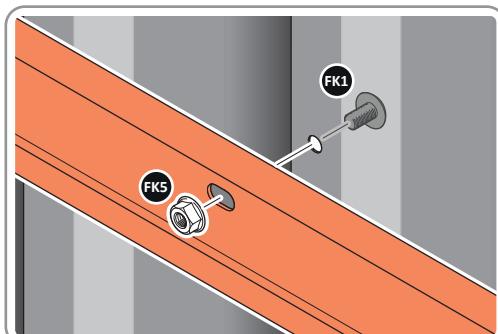
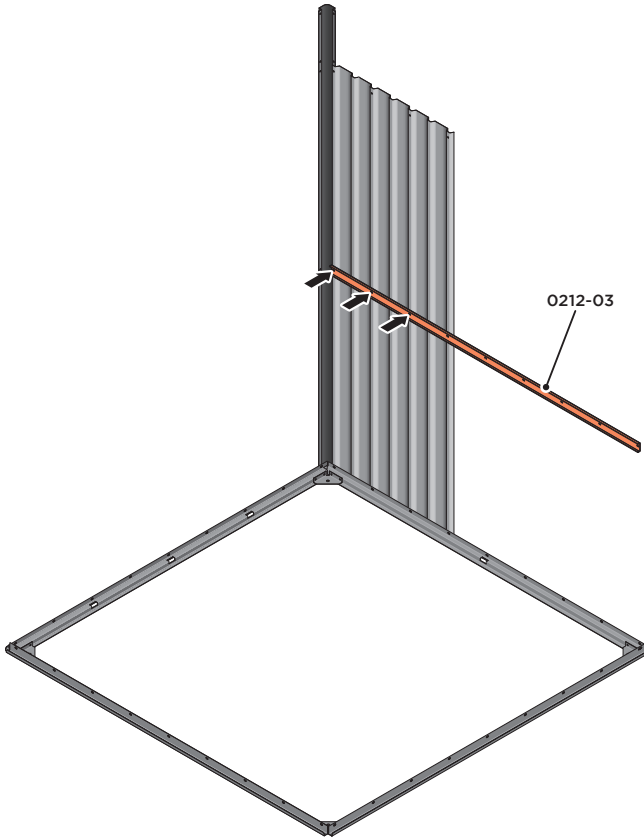

LOCATE AND LOOSELY ATTACH MID CENTRE BRACE 0212-03 AS SHOWN AT x3 LOCATIONS INDICATED ABOVE.

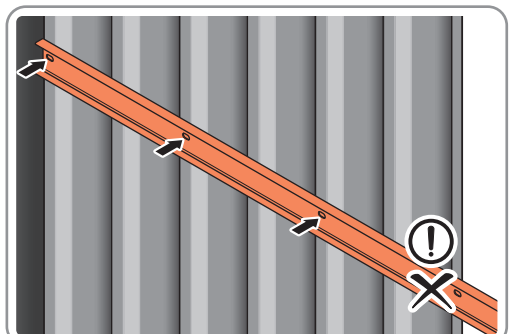

LOOSELY ATTACH AT x3 LOCATIONS INDICATED ONLY.
IMPORTANT: DO NOT SECURE AT OUTER FIXING POINT INDICATED.

Assembly Guide

ASSEMBLY STAGE 5

LOCATE AND LOOSELY ATTACH WALL PANEL 0205-12 (1850 x 625mm).

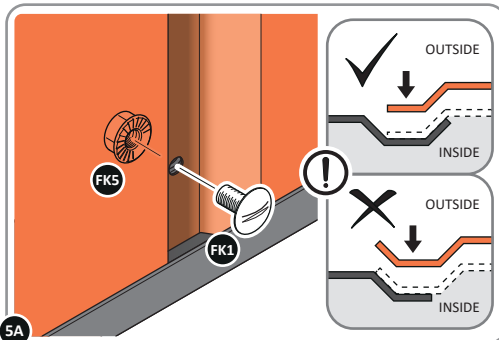
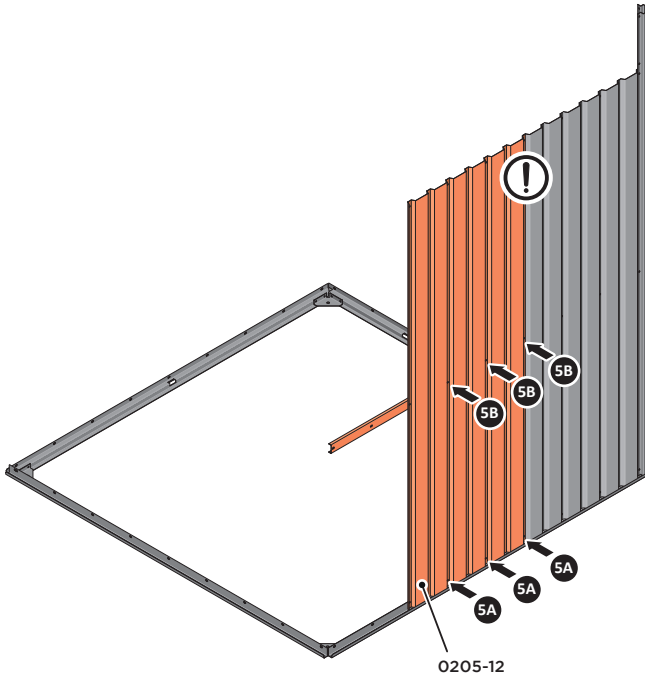

LOCATE AND LOOSELY ATTACH WALL PANEL AT x3 LOCATIONS INDICATED.
IMPORTANT: ENSURE PANEL IS IN THE CORRECT ORIENTATION.

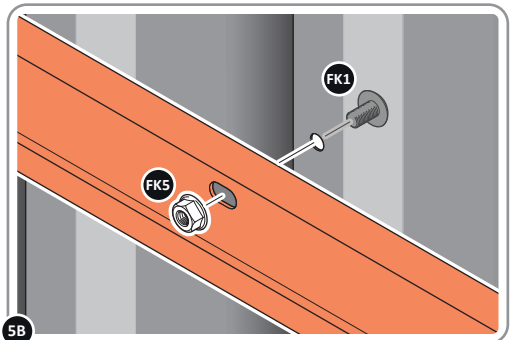

LOOSELY ATTACH AT x3 LOCATIONS INDICATED ONLY.

Assembly Guide

ASSEMBLY STAGE 6

LOCATE AND LOOSELY ATTACH WALL PANEL 0205-13 (1850 x 425mm).

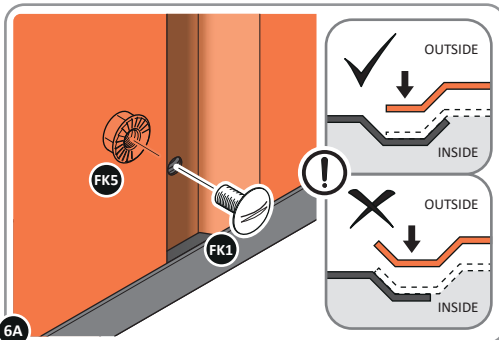
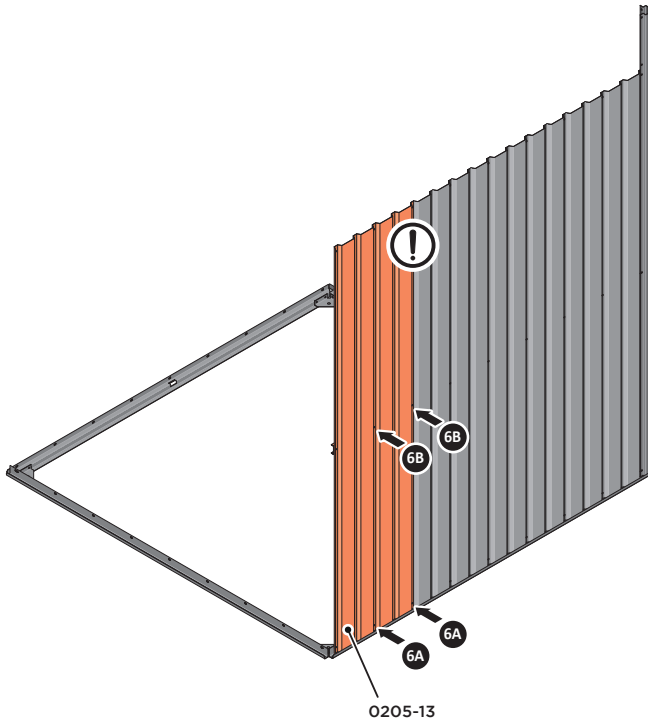

LOCATE AND LOOSELY ATTACH WALL PANEL AT x2 LOCATIONS INDICATED.
IMPORTANT: ENSURE PANEL IS IN THE CORRECT ORIENTATION.

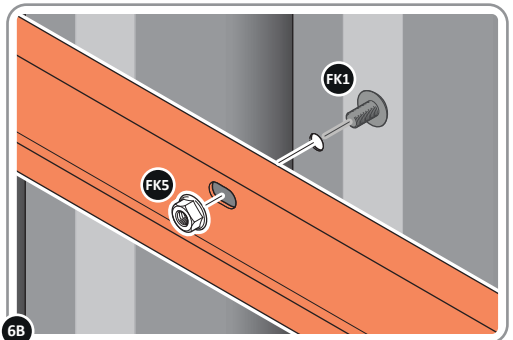

LOOSELY ATTACH AT x2 LOCATIONS INDICATED ONLY.

ASSEMBLY STAGE 7

LOCATE AND LOOSELY ATTACH CORNER POST 0205-14 (1885mm).

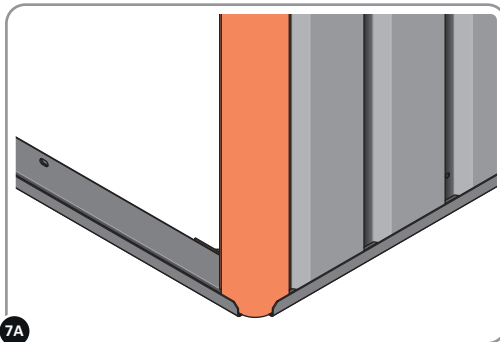
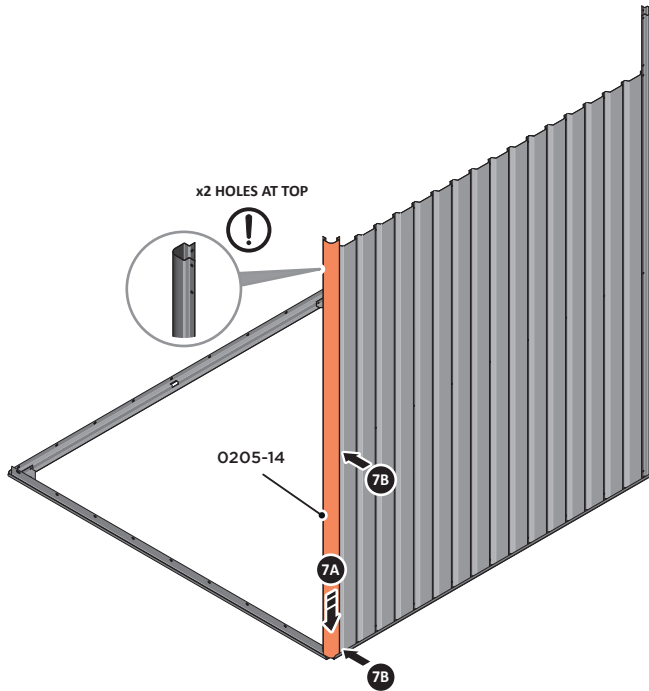

7A LOCATE CORNER POST 0205-14 (1885mm) AS SHOWN ABOVE.

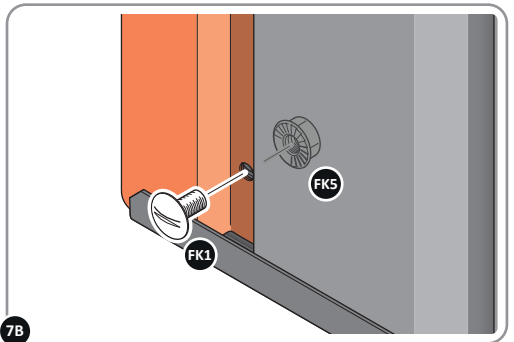

7B LOOSELY ATTACH CORNER POST AT x2 LOCATIONS INDICATED ONLY.
IMPORTANT: DO NOT SECURE AT UPPER FIXING POINT AT THIS STAGE.

ASSEMBLY STAGE 8

LOCATE AND LOOSELY ATTACH WALL PANEL 0205-13 (1850 x 425mm).

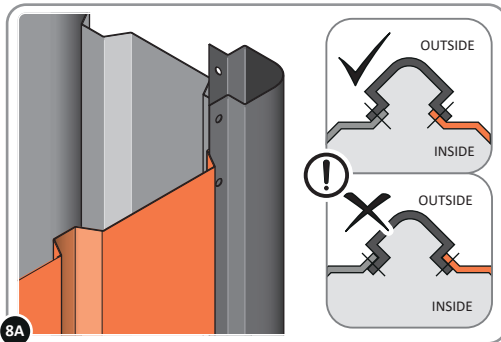
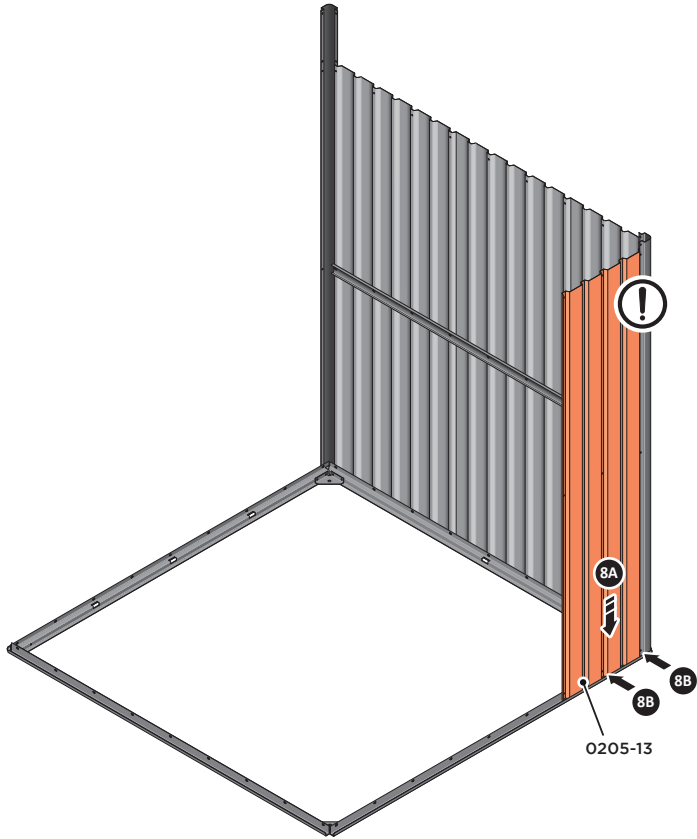

8A LOCATE FIRST WALL PANEL 0205-13 (1850 x 425mm) AS SHOWN ABOVE.
IMPORTANT: ENSURE PANEL IS IN THE CORRECT ORIENTATION.

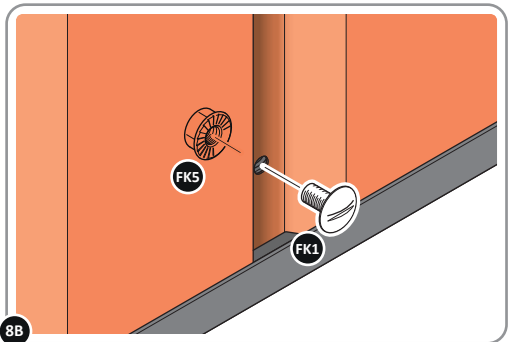

8B LOOSELY ATTACH WALL PANEL AT x2 LOCATIONS INDICATED ONLY.
IMPORTANT: DO NOT SECURE ANY FIXING POINTS OTHER THAN THOSE INDICATED.

ASSEMBLY STAGE 9

LOCATE AND LOOSELY ATTACH WALL PANEL 0205-12 (1850 x 625mm).

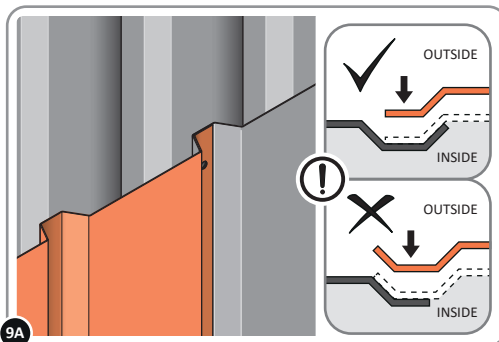
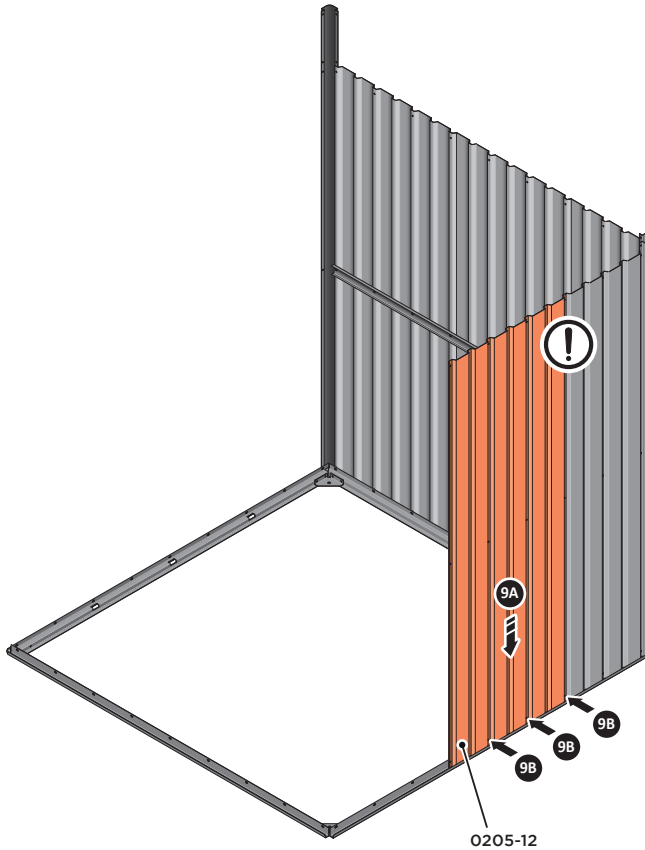

9A
LOCATE WALL PANEL 0205-12 INTO POSITION AS SHOWN ABOVE.
IMPORTANT: ENSURE PANEL IS IN THE CORRECT ORIENTATION.

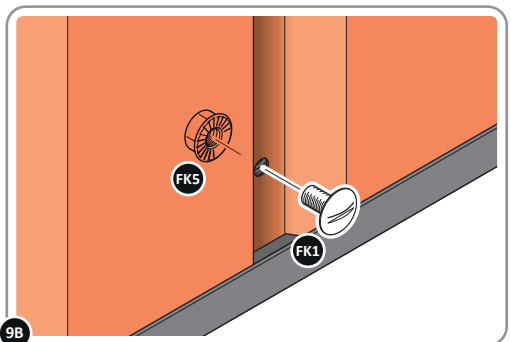

9B
LOOSELY ATTACH BACK WALL PANEL AT x3 LOCATIONS INDICATED ONLY.
IMPORTANT: DO NOT SECURE ANY FIXING POINTS OTHER THAN THOSE INDICATED.

ASSEMBLY STAGE 10

LOCATE AND LOOSELY ATTACH LONG CENTRE BRACE 0212-03.

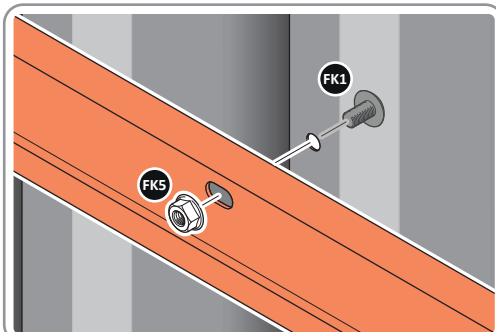
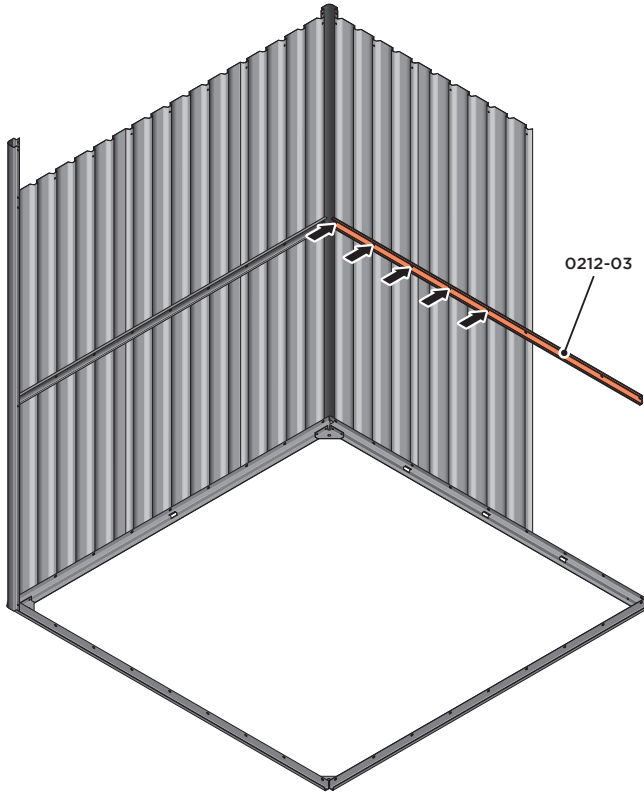

LOCATE AND LOOSELY ATTACH LONG CENTRE BRACE 0212-03 AS SHOWN AT X5 LOCATIONS INDICATED ABOVE.

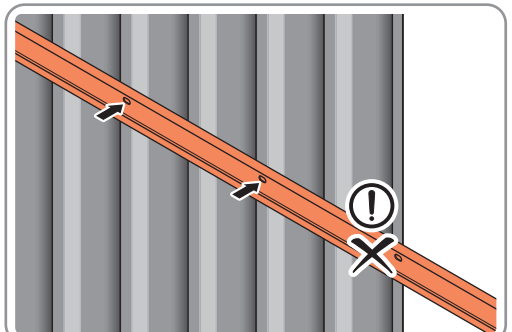

LOOSELY ATTACH AT X5 LOCATIONS INDICATED ONLY.
IMPORTANT: DO NOT SECURE AT OUTER FIXING POINT INDICATED.

Assembly Guide

ASSEMBLY STAGE 11

LOCATE AND LOOSELY ATTACH WALL PANEL 0205-12 (1850 x 625mm).

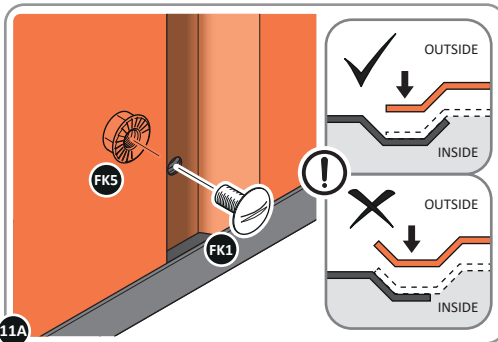
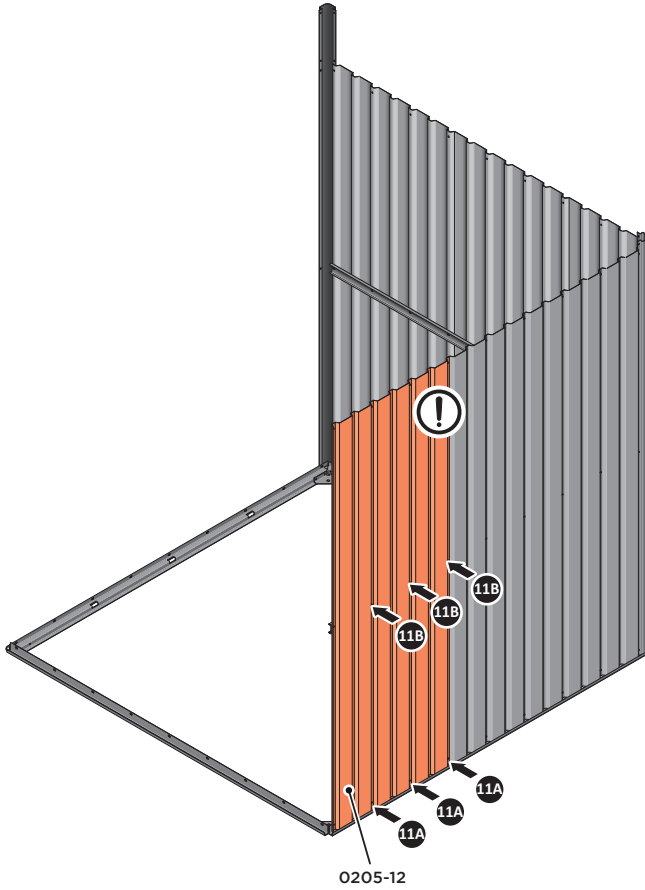

LOCATE AND LOOSELY ATTACH WALL PANEL AT x3 LOCATIONS INDICATED.
IMPORTANT: ENSURE PANEL IS IN THE CORRECT ORIENTATION.

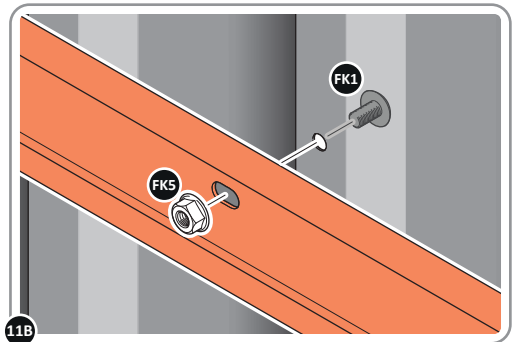

LOOSELY ATTACH AT x3 LOCATIONS INDICATED ONLY.

ASSEMBLY STAGE 12

LOCATE AND LOOSELY ATTACH CORNER POST 0205-14 (1885mm).

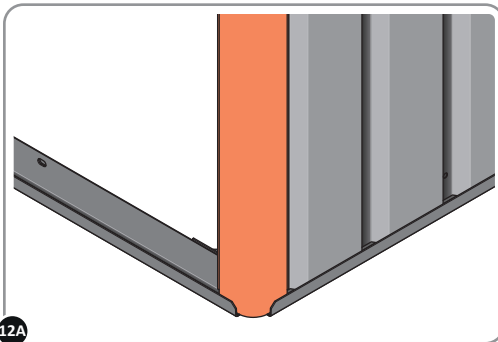
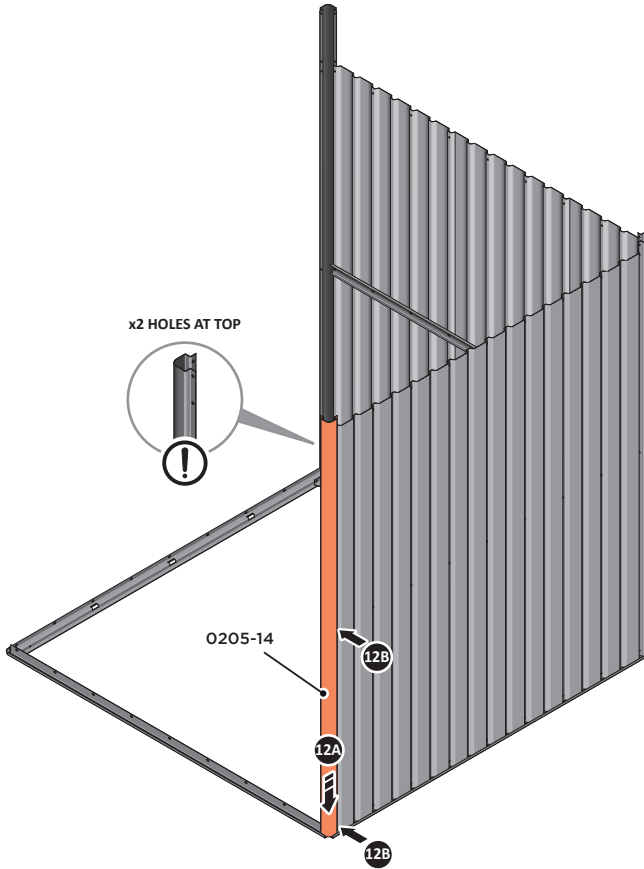

12A

LOCATE CORNER POST 0205-14 (1885mm) AS SHOWN ABOVE.

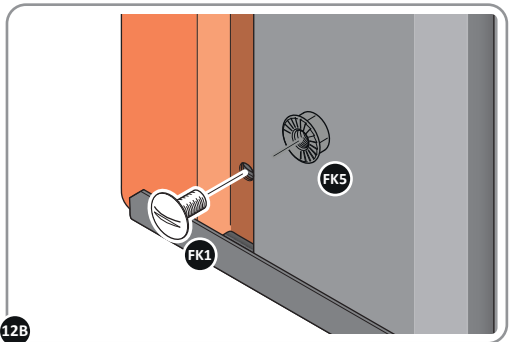

12B

LOOSELY ATTACH CORNER POST AT x2 LOCATIONS INDICATED ONLY.
IMPORTANT: DO NOT SECURE AT UPPER FIXING POINT AT THIS STAGE.

Assembly Guide

ASSEMBLY STAGE 13

LOCATE AND LOOSELY ATTACH WALL PANEL 0205-13 (1850 x 425mm).

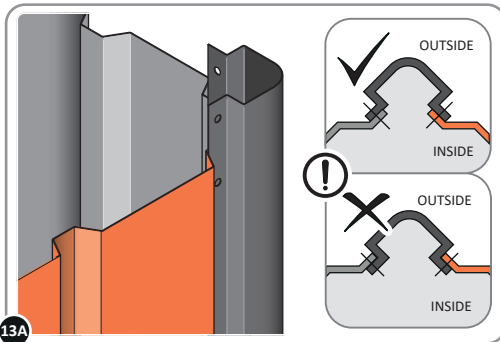
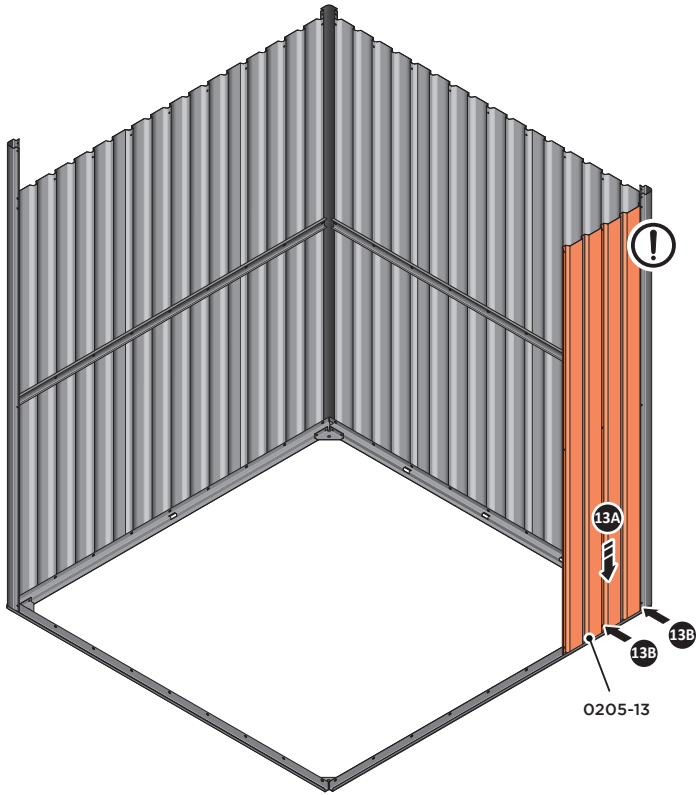

13A

LOCATE FIRST WALL PANEL 0205-13 (1850 x 425mm) AS SHOWN ABOVE.
IMPORTANT: ENSURE PANEL IS IN THE CORRECT ORIENTATION.

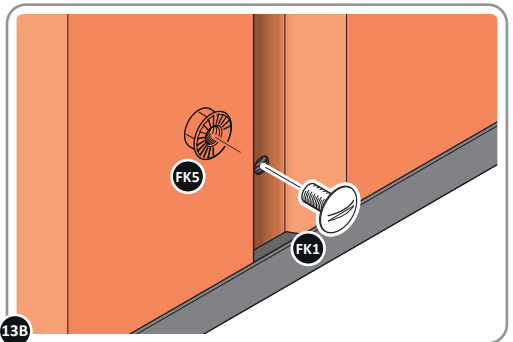

13B

LOOSELY ATTACH WALL PANEL AT x2 LOCATIONS INDICATED ONLY.
IMPORTANT: DO NOT SECURE ANY FIXING POINTS OTHER THAN THOSE INDICATED.

Assembly Guide

ASSEMBLY STAGE 14

LOCATE AND LOOSELY ATTACH WALL PANEL 0205-12 (1850 x 625mm).

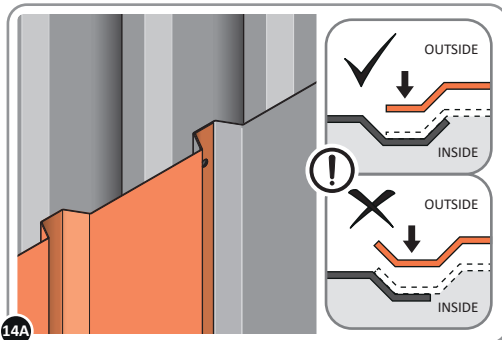
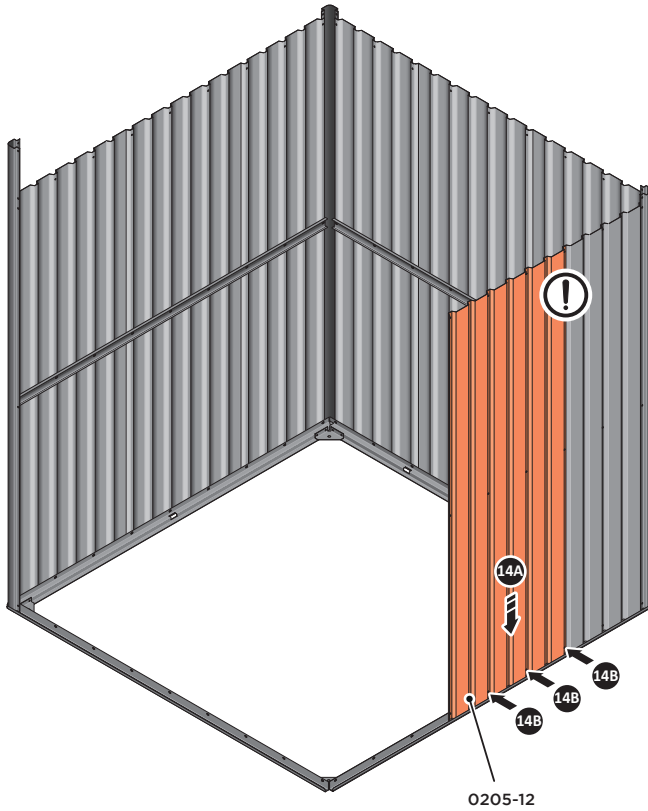

14A

LOCATE WALL PANEL 0205-12 INTO POSITION AS SHOWN ABOVE.
IMPORTANT: ENSURE PANEL IS IN THE CORRECT ORIENTATION.

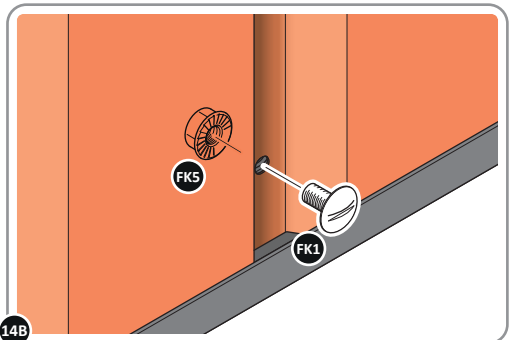

14B

LOOSELY ATTACH WALL PANEL AT x3 LOCATIONS INDICATED ONLY.
IMPORTANT: DO NOT SECURE ANY FIXING POINTS OTHER THAN THOSE INDICATED.

ASSEMBLY STAGE 15

LOCATE AND LOOSELY ATTACH MID CENTRE BRACE 0212-03.

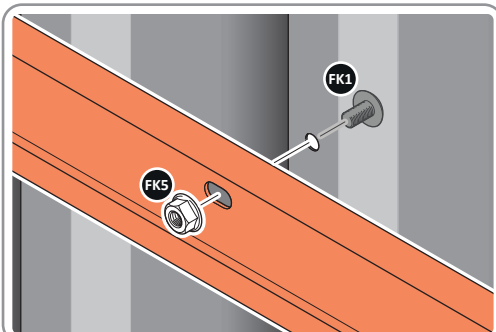
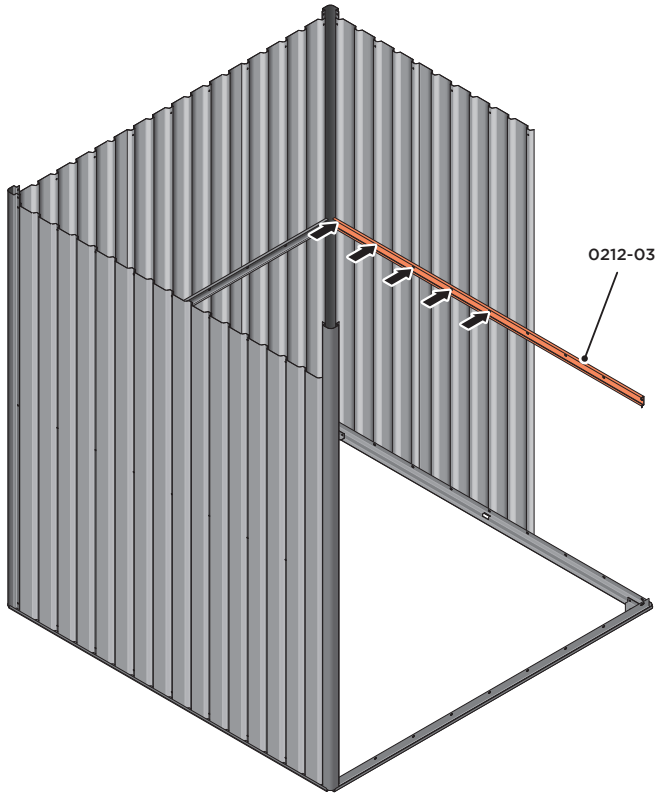

LOCATE AND LOOSELY ATTACH MID CENTRE BRACE 0212-03 AS SHOWN AT X5 LOCATIONS INDICATED ABOVE.

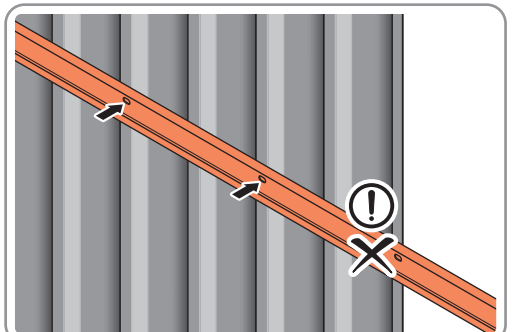

LOOSELY ATTACH AT X5 LOCATIONS INDICATED ONLY.
IMPORTANT: DO NOT SECURE AT OUTER FIXING POINT INDICATED.

Assembly Guide

ASSEMBLY STAGE 16

LOCATE AND LOOSELY ATTACH WALL PANEL 0205-12 (1850 x 625mm).

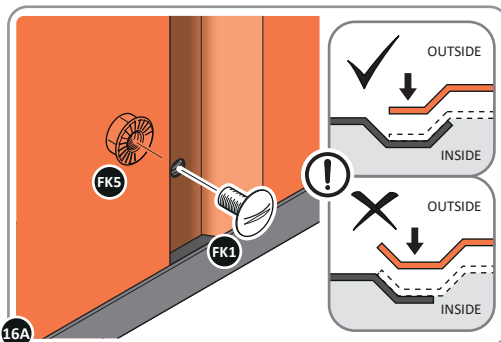
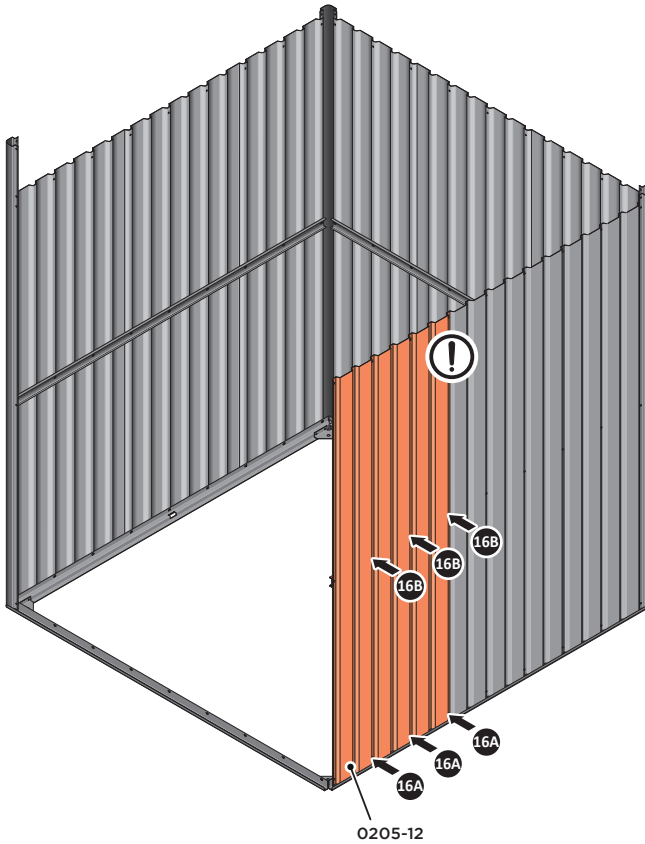

LOCATE AND LOOSELY ATTACH WALL PANEL AT x3 LOCATIONS INDICATED.
IMPORTANT: ENSURE PANEL IS IN THE CORRECT ORIENTATION.

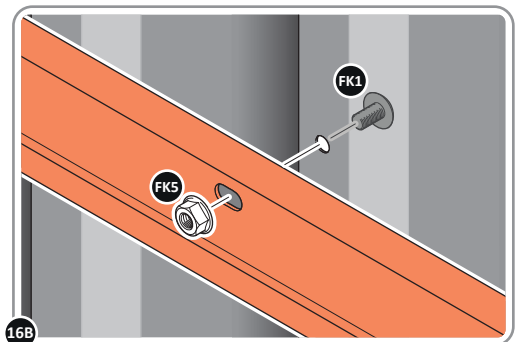

LOOSELY ATTACH AT x3 LOCATIONS INDICATED ONLY.

ASSEMBLY STAGE 17

LOCATE AND LOOSELY ATTACH CORNER POST 0205-15 (2100mm).

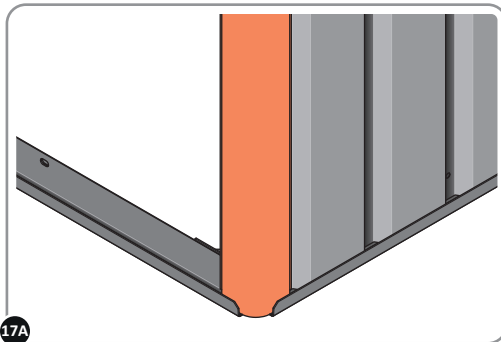
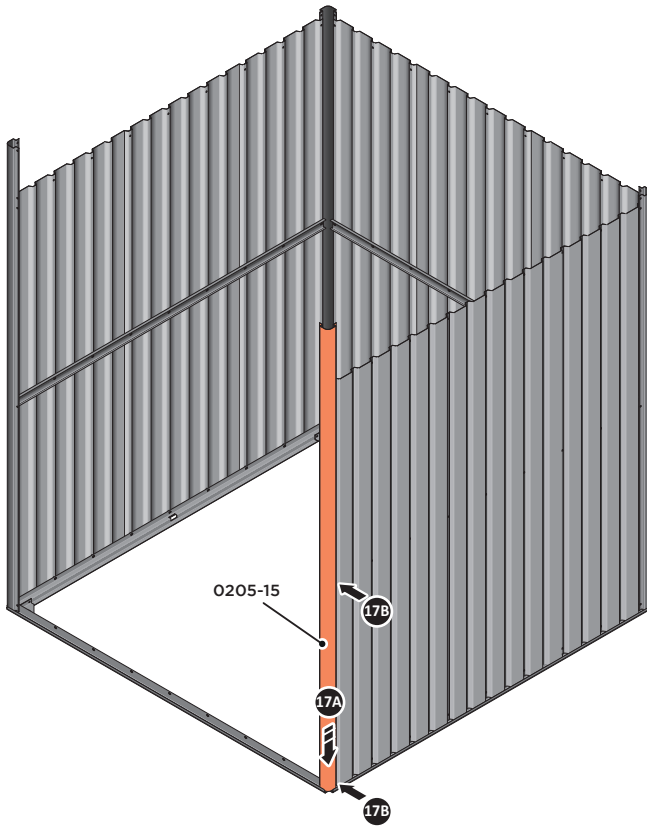

17A LOCATE CORNER POST 0205-15 (2100mm) AS SHOWN ABOVE.

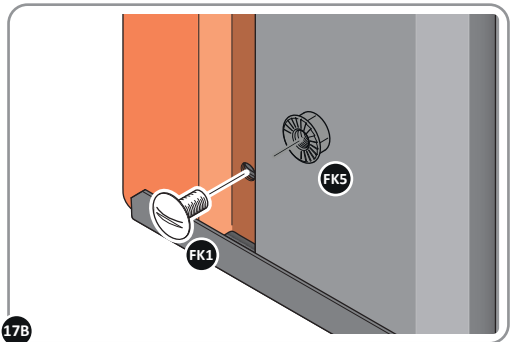

17B LOOSELY ATTACH CORNER POST AT x2 LOCATIONS INDICATED ONLY.
IMPORTANT: DO NOT SECURE AT UPPER FIXING POINT AT THIS STAGE.

Assembly Guide

ASSEMBLY STAGE 18

LOCATE AND LOOSELY ATTACH RIGHT-HAND DOOR POST 0205-16.

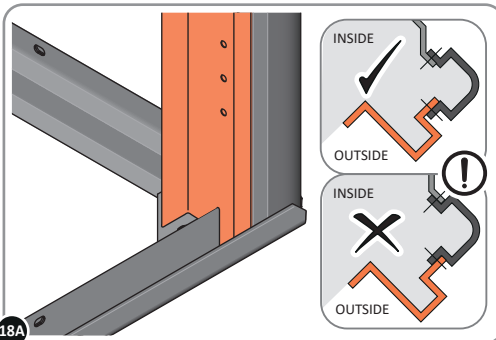
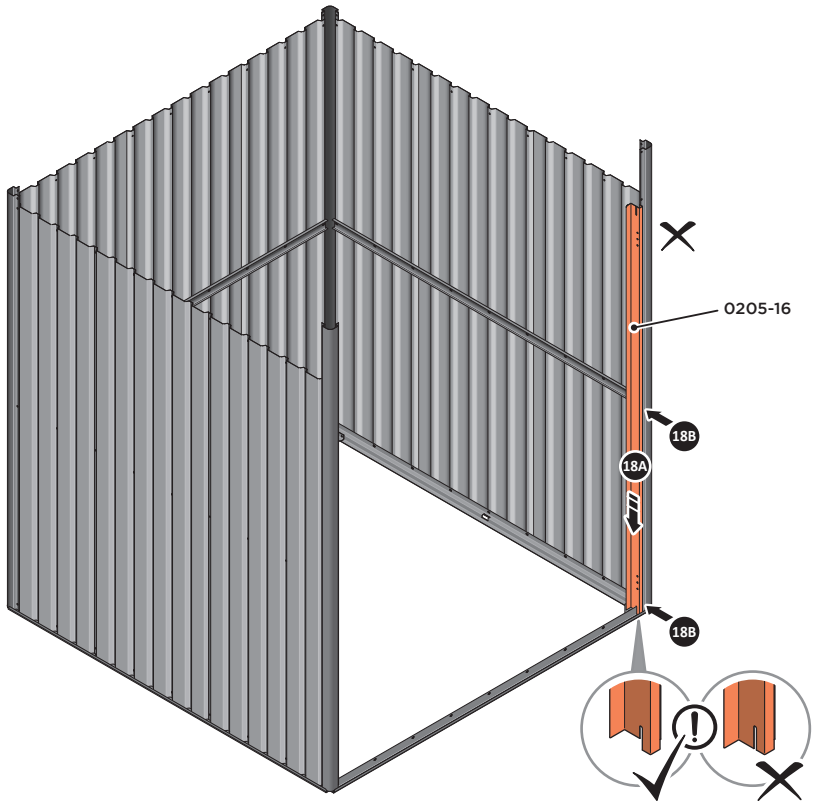

18A LOCATE RIGHT-HAND DOOR POST 0205-16 AS SHOWN ABOVE.

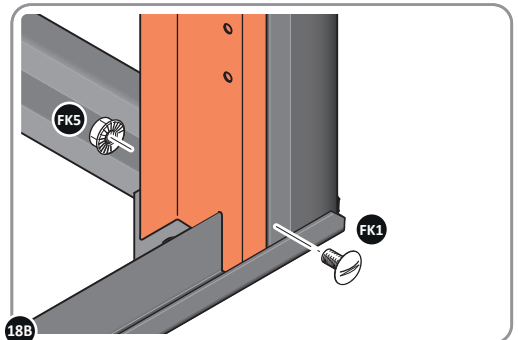

18B SECURE DOOR POST AT x2 LOCATIONS INDICATED.
IMPORTANT: DO NOT SECURE AT UPPER FIXING POINT AT THIS STAGE.

ASSEMBLY STAGE 19

LOCATE AND LOOSELY ATTACH LEFT-HAND DOOR POST 0205-17.

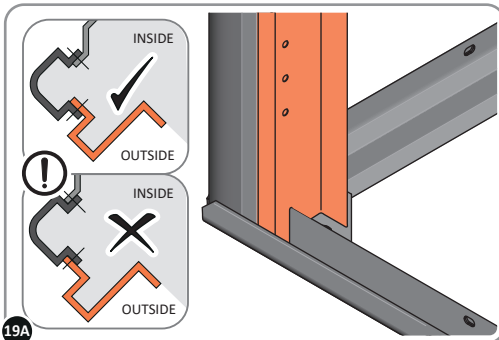
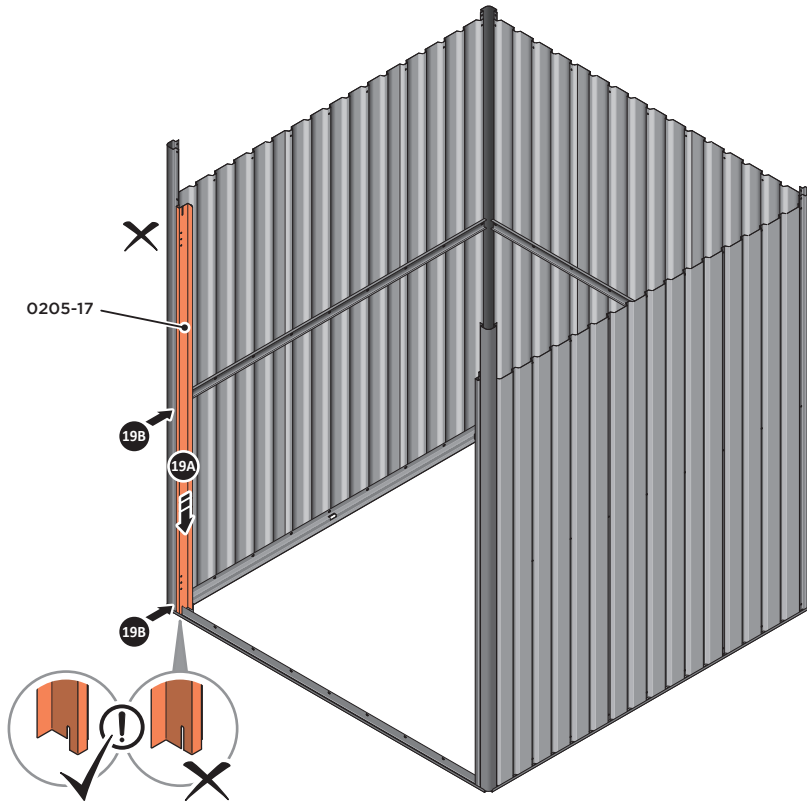

19A LOCATE RIGHT-HAND DOOR POST 0205-17 AS SHOWN ABOVE.

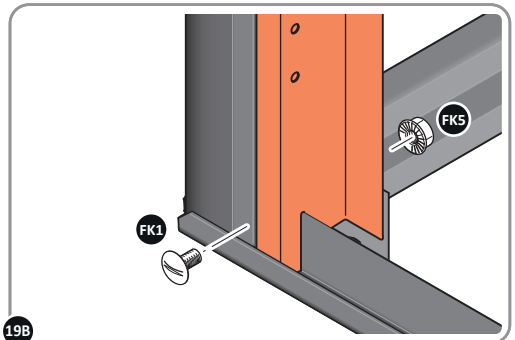

19B SECURE DOOR POST AT x2 LOCATIONS INDICATED.
IMPORTANT: DO NOT SECURE AT UPPER FIXING POINT AT THIS STAGE.

ASSEMBLY STAGE 20

LOCATE AND LOOSELY ATTACH SHORT ROOF RAIL 0215-02.

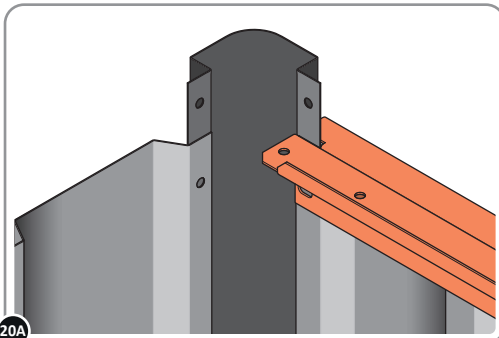
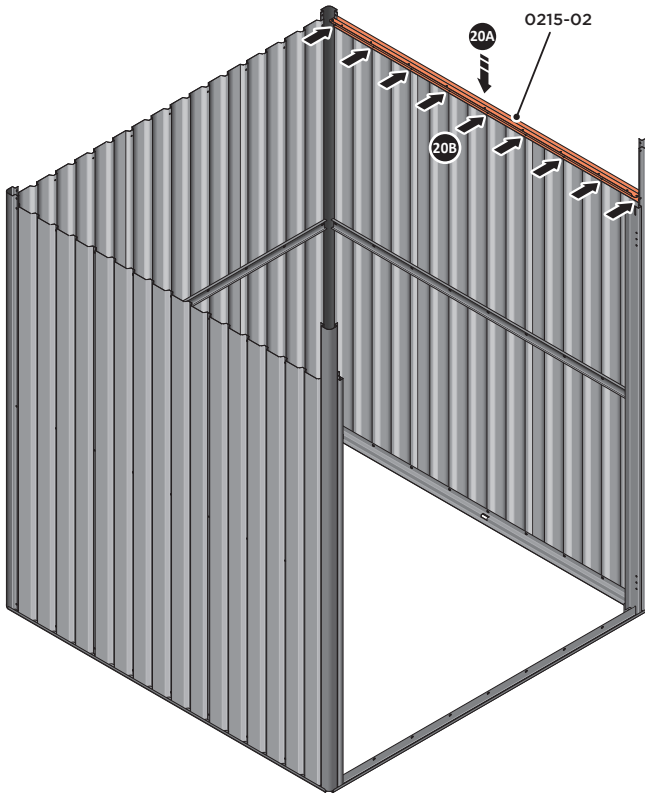

20A
LOCATE SHORT ROOF RAIL 0215-02 AS SHOWN ABOVE.

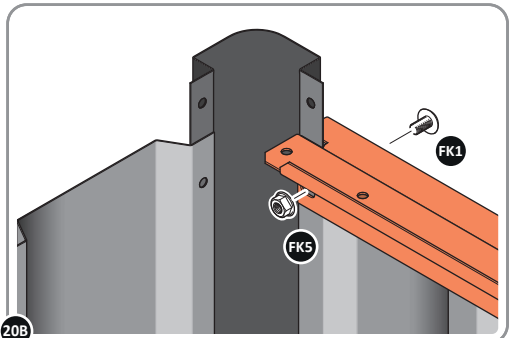

20B
LOOSELY ATTACH AT x9 LOCATIONS INDICATED.

ASSEMBLY STAGE 21

LOCATE AND LOOSELY ATTACH SHORT ROOF RAIL 0215-02.

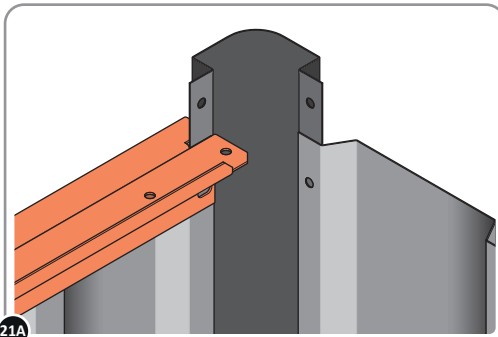
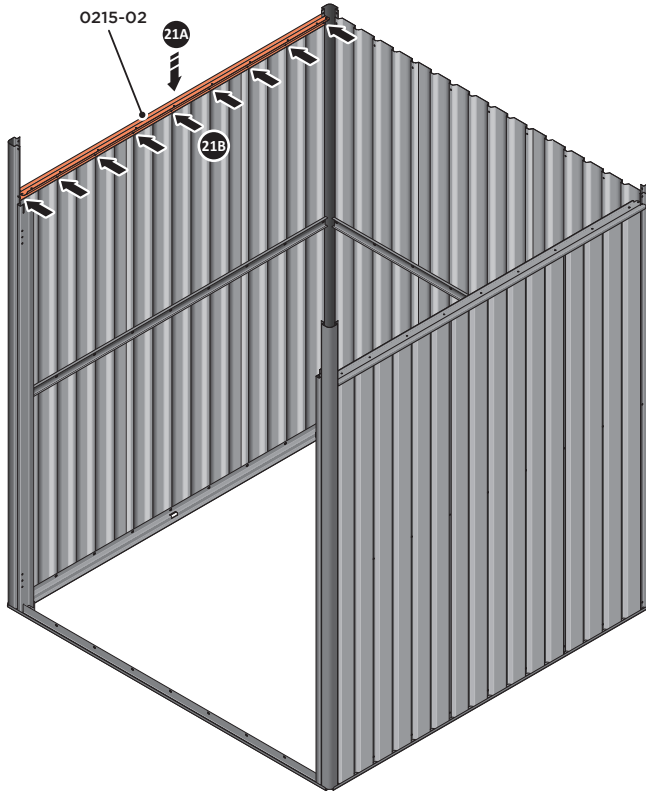

21A LOCATE SHORT ROOF RAIL 0215-02 AS SHOWN ABOVE.

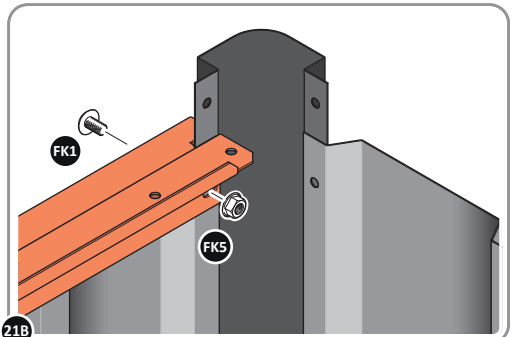

21B LOOSELY ATTACH AT x9 LOCATIONS INDICATED.

ASSEMBLY STAGE 22

LOCATE AND LOOSELY ATTACH LONG ROOF RAIL 0215-02.

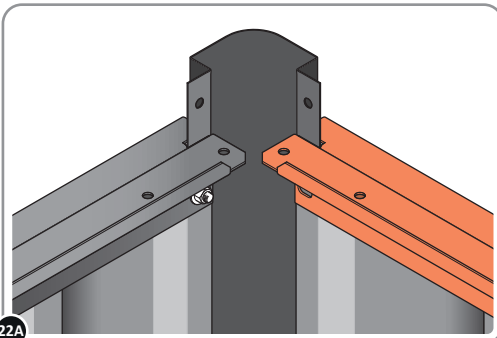
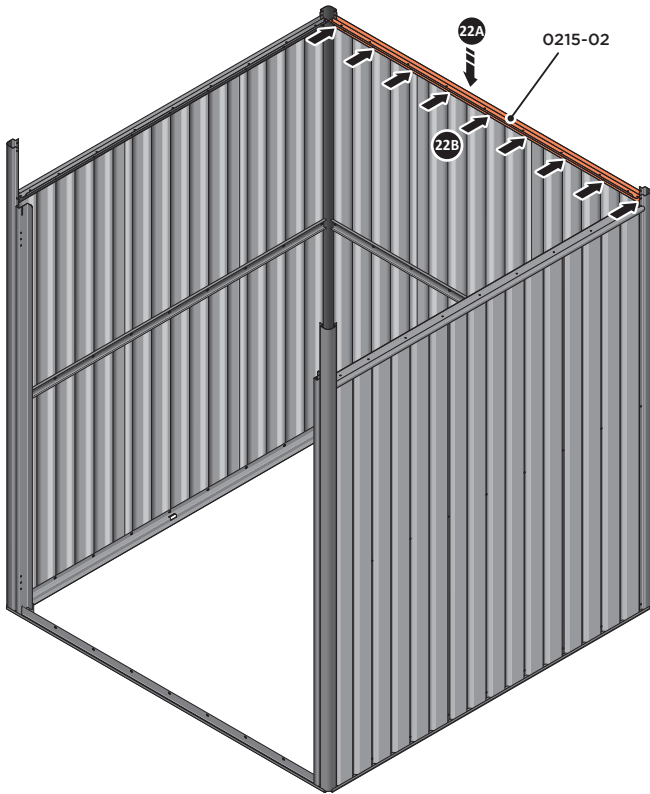

22A LOCATE LONG ROOF RAIL 0215-02 AS SHOWN ABOVE.

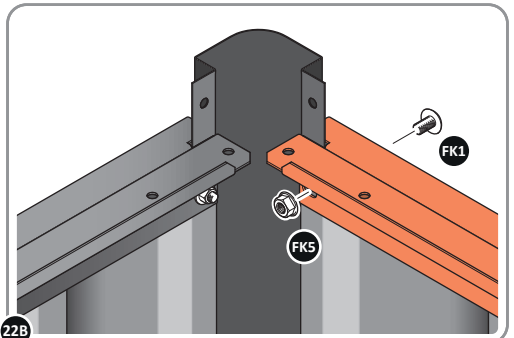

22B LOOSELY ATTACH AT x9 LOCATIONS INDICATED.

Assembly Guide

ASSEMBLY STAGE 23

LOCATE AND LOOSELY ATTACH LONG ROOF RAIL 0215-02.

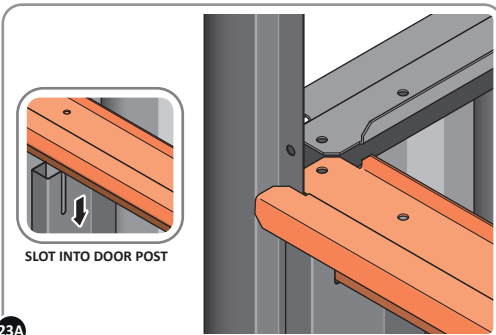
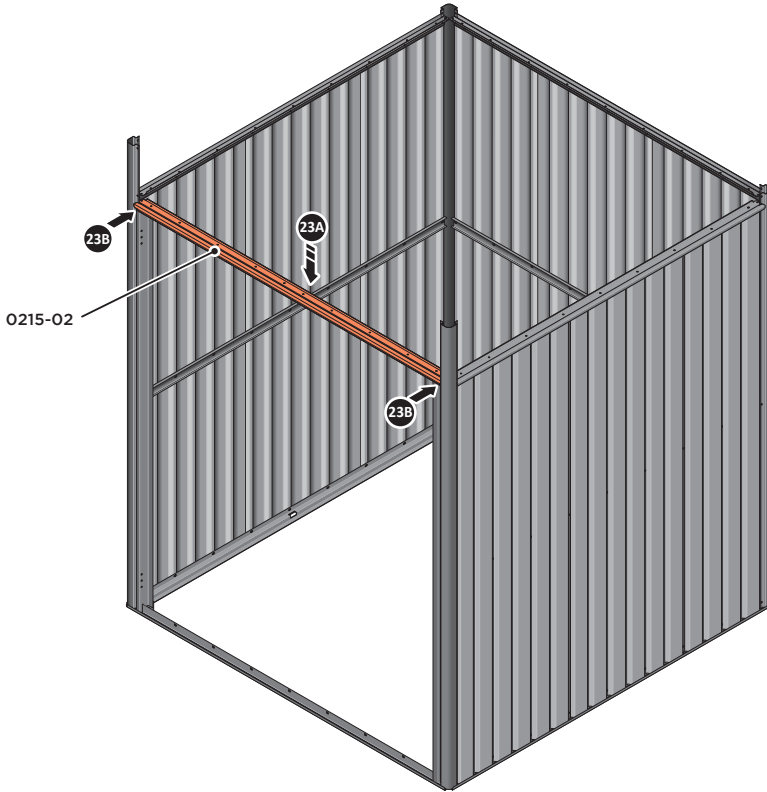

SLOT INTO DOOR POST

23A LOCATE LONG TOP RAIL 0215-02 AS SHOWN ABOVE.

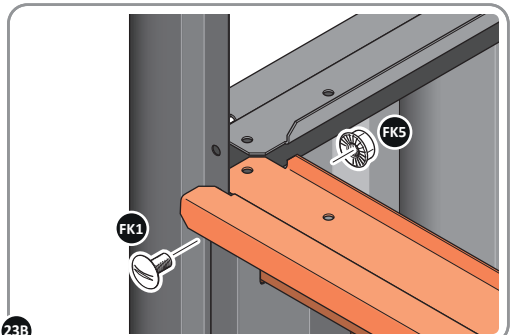

23B LOOSELY ATTACH AT x2 LOCATIONS INDICATED.

ASSEMBLY STAGE 24

LOCATE GROUND ANCHOR BRACKETS 0205-57.

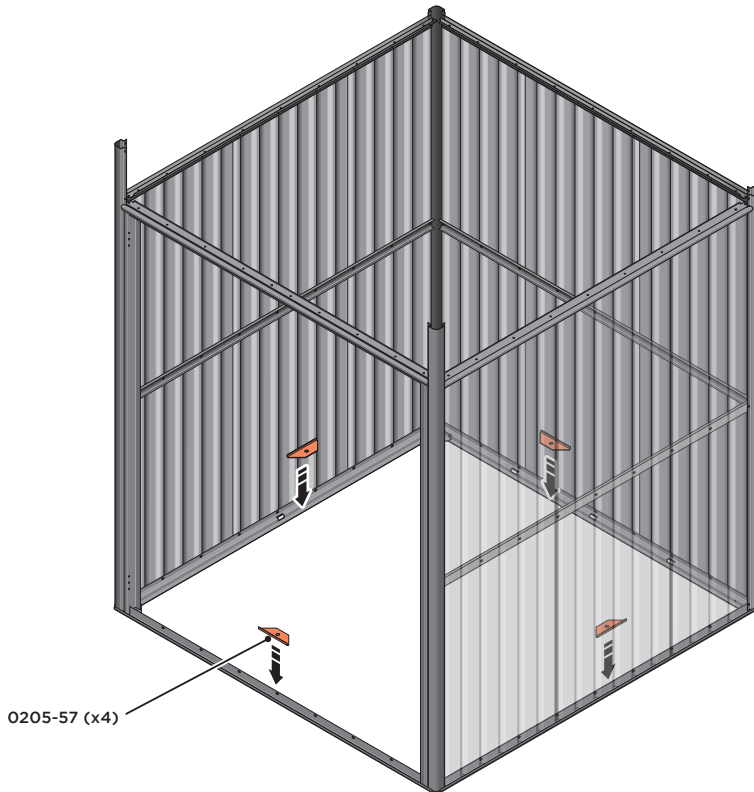

! THESE BRACKETS ARE SECURED USING GROUND ANCHOR KIT ONCE THE SHED WALL PANELS ARE FULLY ASSEMBLED (SEE PAGE 1) !

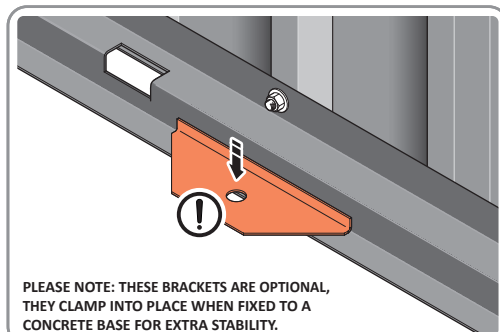

LOCATE x4 GROUND ANCHOR BRACKETS 0205-57 AS SHOWN ABOVE, THESE ALLOW FOR FIXING TO A CONCRETE BASE AT A LATER STAGE IF DESIRED.

ASSEMBLY STAGE 25

LOCATE AND SECURE DOOR STRIP 0205-74

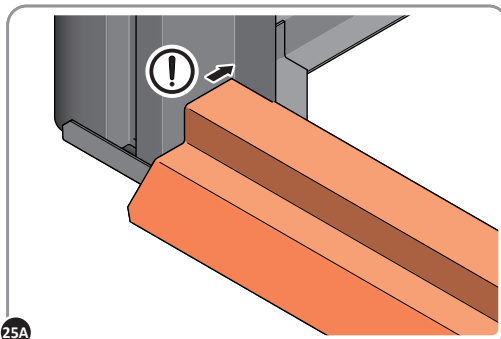
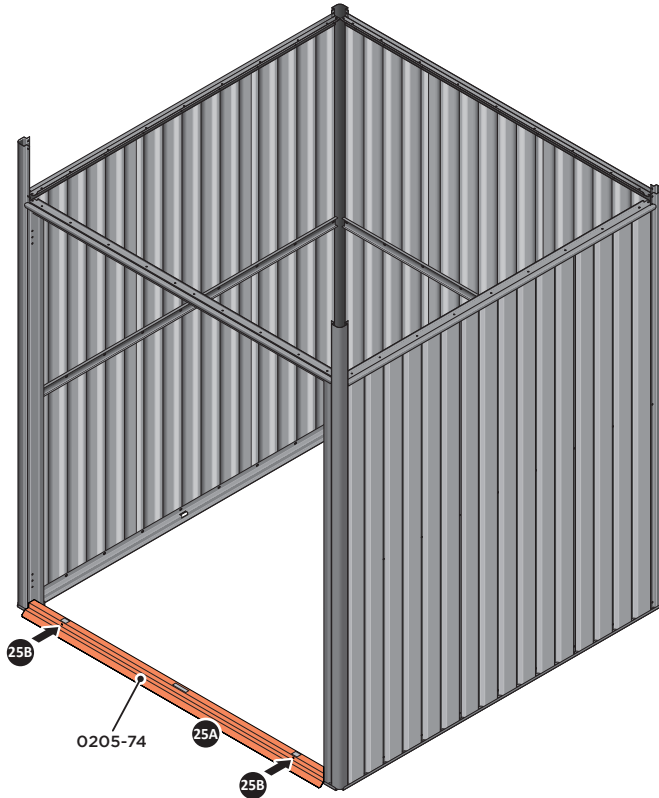

25A

LOCATE DOOR STRIP 0205-74 AS SHOWN.

IMPORTANT: ENSURE DOOR STRIP IS PUSHED AGAINST DOOR POST RETURN.

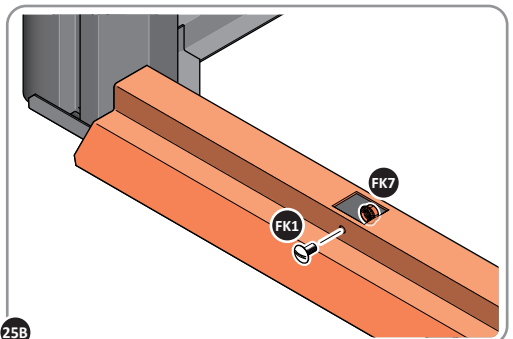

25B

SECURE DOOR STRIP ONTO FLOOR PANELS AT x2 LOCATIONS INDICATED, USE EXISTING HOLE AS A LOCATION GUIDE.

ASSEMBLY STAGE 26

LOCATE AND SECURE ROOF SIDE INFILL 0212-11.

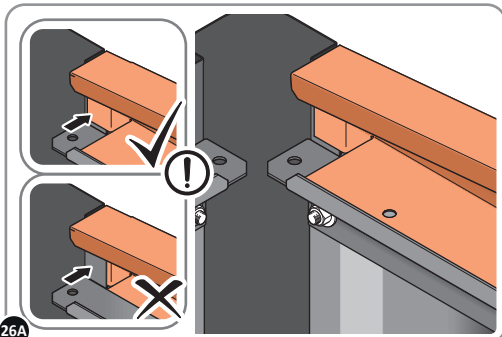
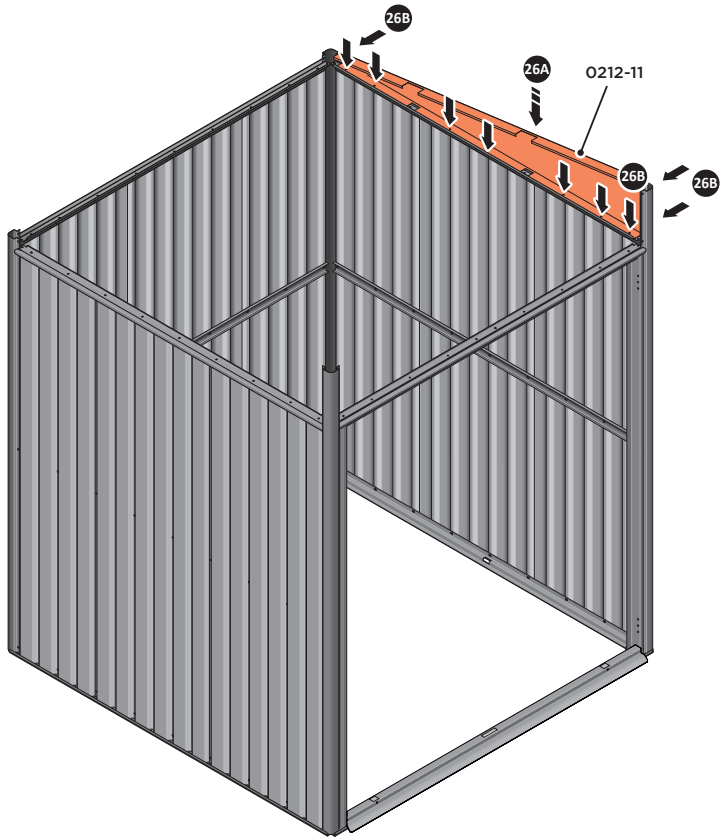

26A LOCATE ROOF SIDE INFILL 0212-11 AS SHOWN ABOVE.

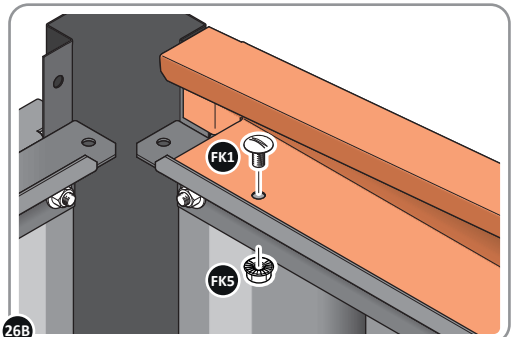

26B SECURE ROOF SIDE INFILL AT LOCATIONS INDICATED AS SHOWN ABOVE.

ASSEMBLY STAGE 27

LOCATE AND SECURE ROOF SIDE INFILL 0212-12.

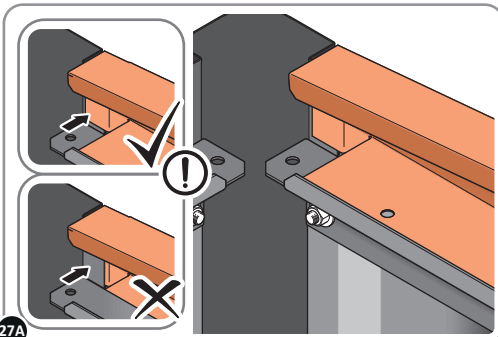
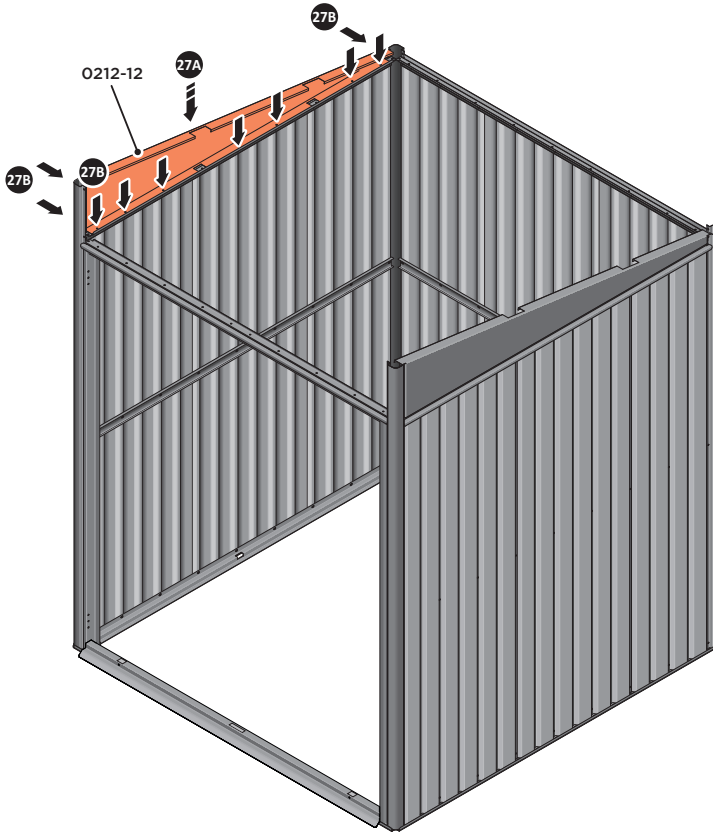

27A LOCATE ROOF SIDE INFILL 0212-12 AS SHOWN ABOVE.

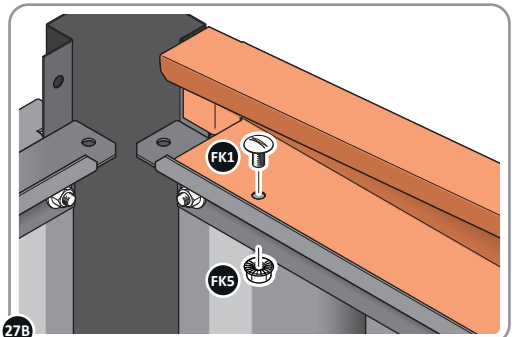

27B SECURE ROOF SIDE INFILL AT LOCATIONS INDICATED AS SHOWN ABOVE.

ASSEMBLY STAGE 28

LOCATE AND SECURE ROOF REAR INFILL 0215-11.

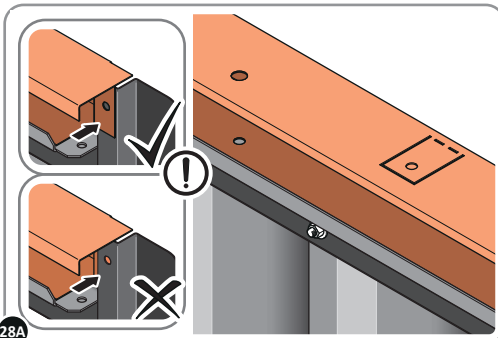
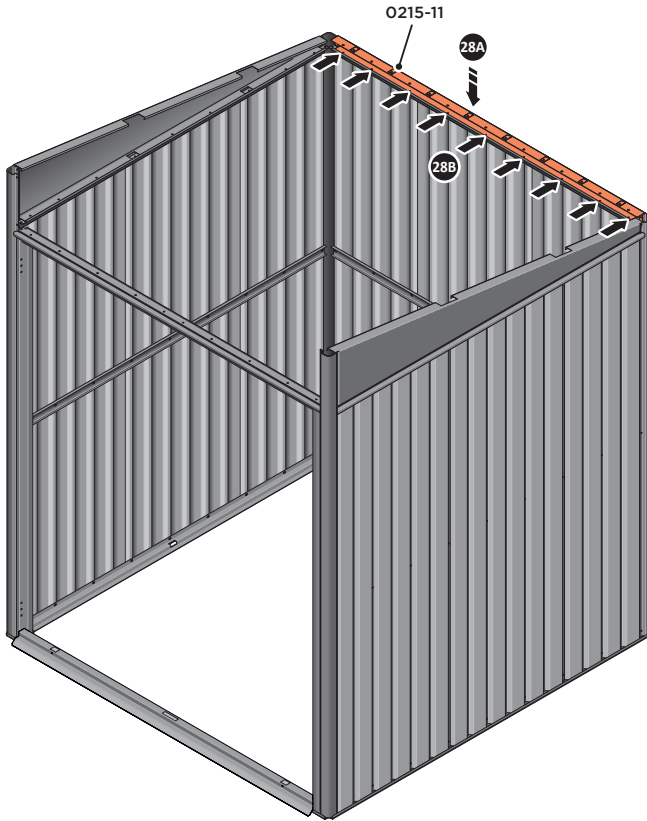

LOCATE ROOF REAR INFILLS 0215-11 AS SHOWN ABOVE.

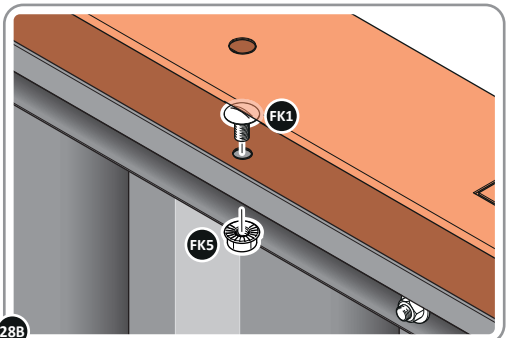

SECURE ROOF REAR INFILL AT X9 LOCATIONS INDICATED AS SHOWN ABOVE.

Assembly Guide

ASSEMBLY STAGE 29

LOCATE AND SECURE WINDOW ASSEMBLY 0215-12.

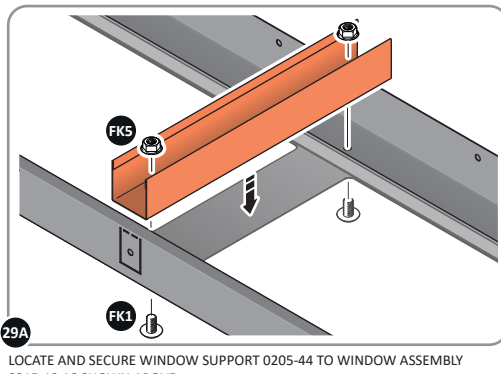
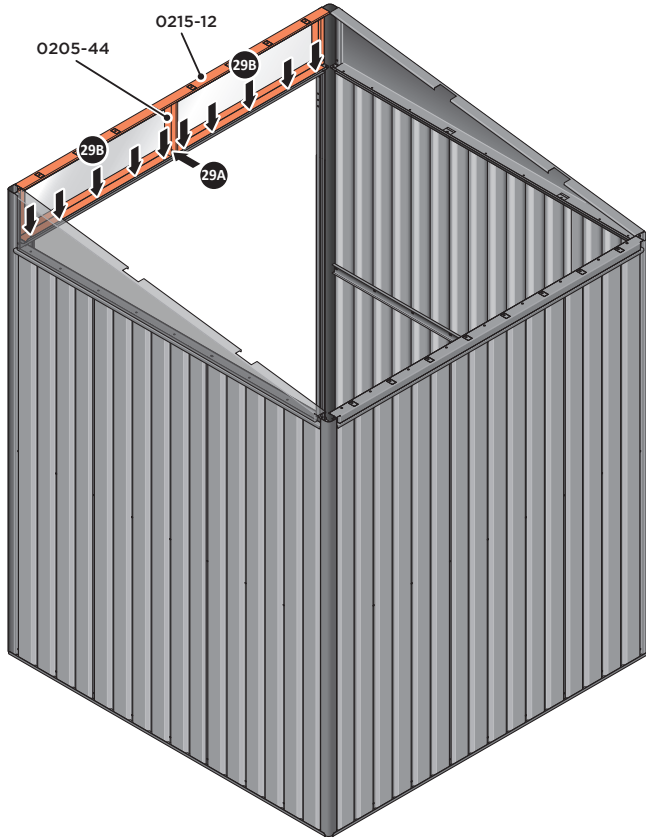

LOCATE AND SECURE WINDOW SUPPORT 0205-44 TO WINDOW ASSEMBLY 0215-12 AS SHOWN ABOVE.

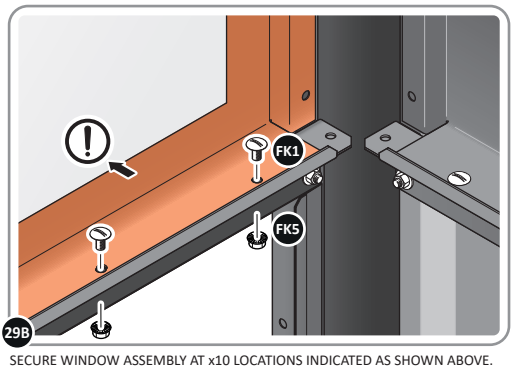

SECURE WINDOW ASSEMBLY AT x10 LOCATIONS INDICATED AS SHOWN ABOVE.

ASSEMBLY STAGE 30

LOCATE AND SECURE ROOF FRONT INFILLS 0215-12.

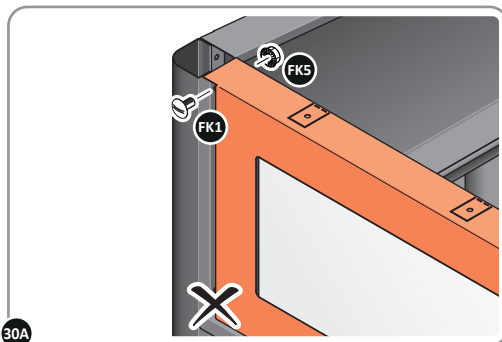
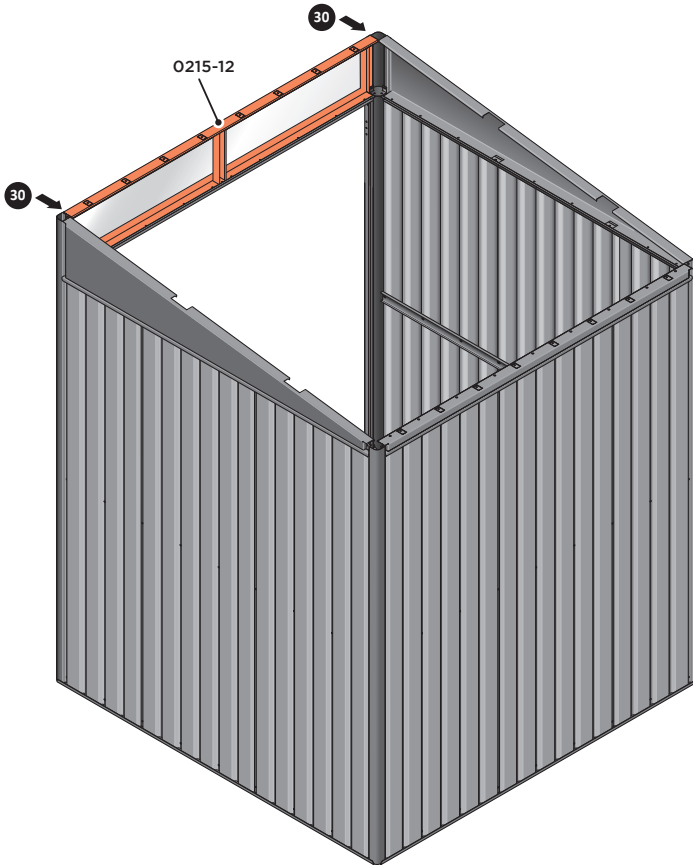

30A

SECURE ROOF FRONT INFILLS AT x2 LOCATIONS INDICATED.

ASSEMBLY STAGE 31

LOCATE AND SECURE TOP RAIL CORNER BRACKETS 0203-15.

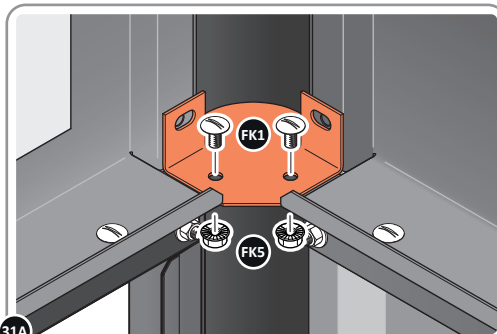
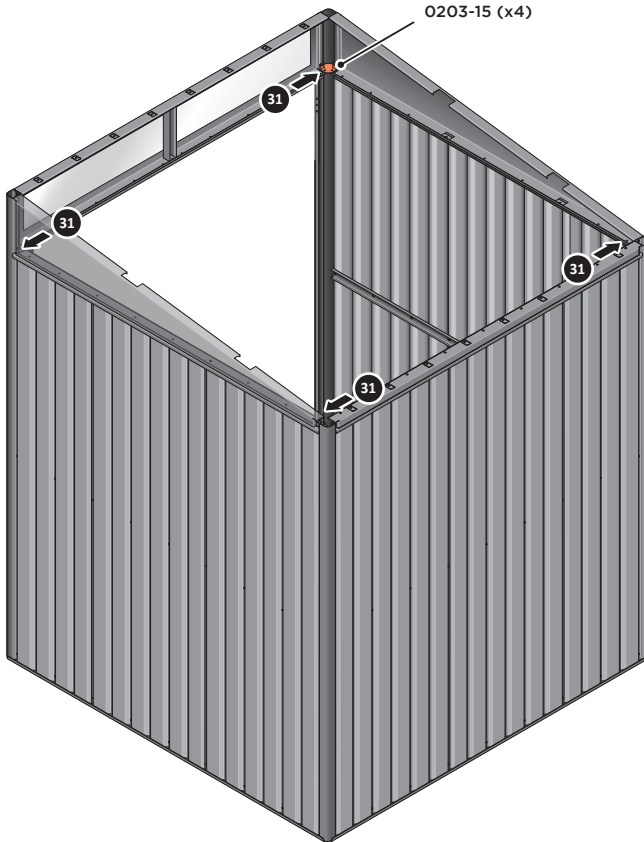

31A

LOCATE AND SECURE TOP RAIL CORNER BRACKETS 0203-15 IN EACH CORNER OF THE SHED USING THE TYPICAL FIXING METHOD SHOWN ABOVE.

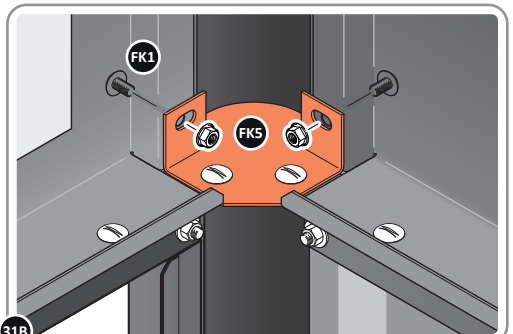

31B

SECURE EACH CORNER BRACKET AND ROOF INFILL AS SHOWN ABOVE.

ASSEMBLY STAGE 32

LOCATE AND SECURE ROOF SUPPORTS 0212-13 AND 0212-14.

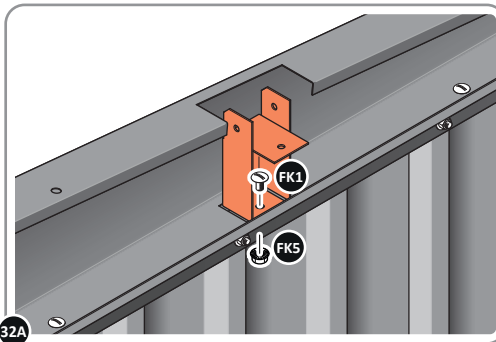
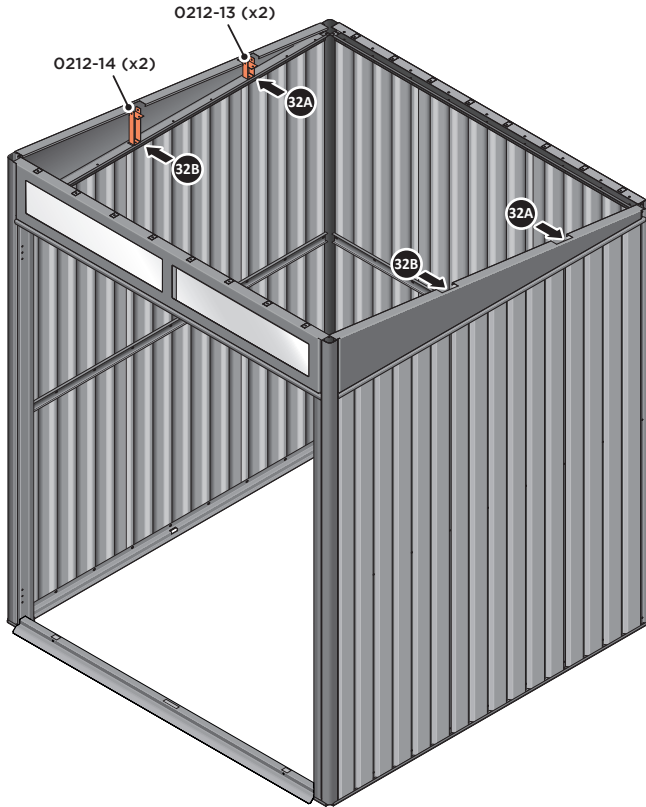

LOCATE AND SECURE SHORT ROOF SUPPORT 0212-13 AS SHOWN ABOVE.

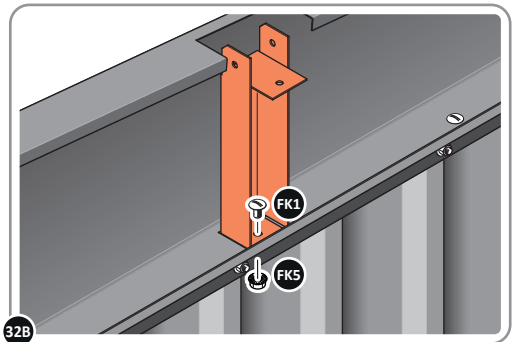

LOCATE AND SECURE LONG ROOF SUPPORT 0212-14 AS SHOWN ABOVE.

ASSEMBLY STAGE 33

LOCATE AND SECURE ROOF CHANNEL ASSEMBLY 0215-06.

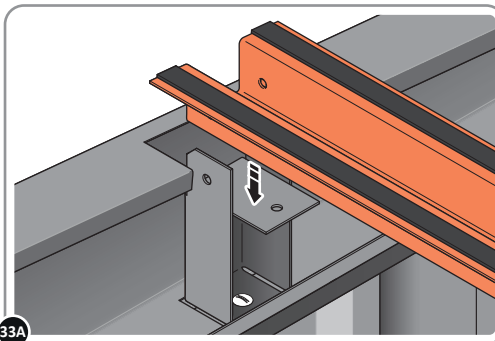
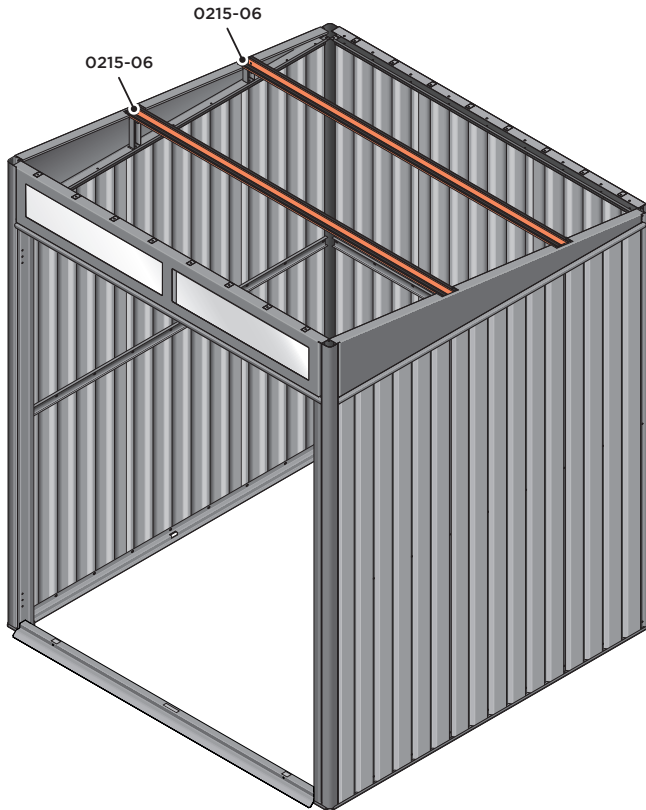

33A

SLOT EACH ROOF CHANNEL ASSEMBLY 0215-06 INTO ROOF SUPPORT.

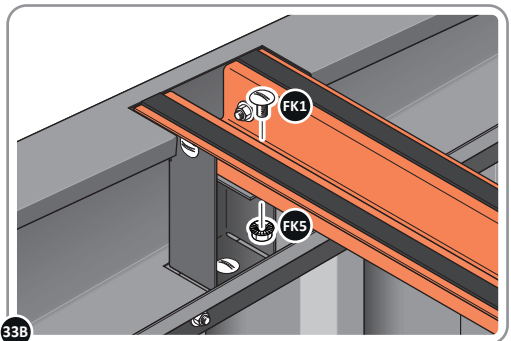

33B

SECURE ROOF CHANNEL ASSEMBLY AT EACH FIXING POINT (x3 EACH SIDE) USING FASTENERS DETAILED ABOVE.

ASSEMBLY STAGE 34

PUSH ROOF REAR AND FRONT INFILL AIR BEND TABS UPWARDS.

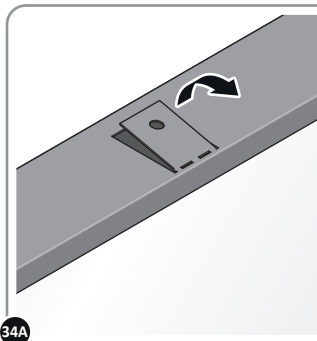
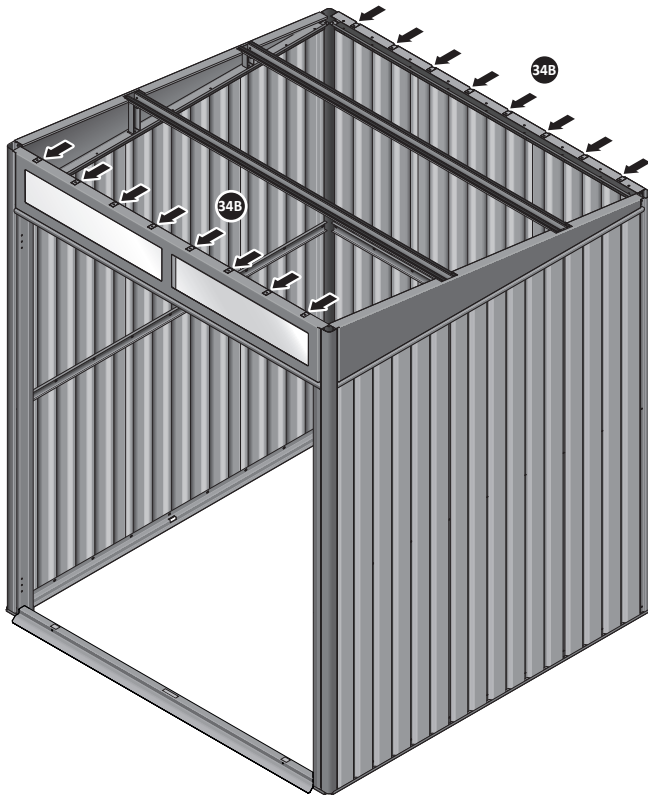

34A

BEND ROOF FRONT INFILL AIR BEND TABS UPWARDS.
IMPORTANT: DO NOT BEND PAST 45°.

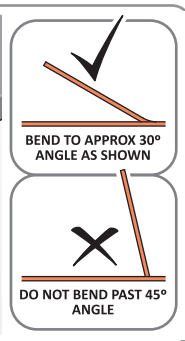

BEND TO APPROX 30°
ANGLE AS SHOWN

DO NOT BEND PAST 45°
ANGLE



34B

BEND ROOF REAR INFILL AIR BEND TABS UPWARDS
IMPORTANT: DO NOT BEND PAST 45°.

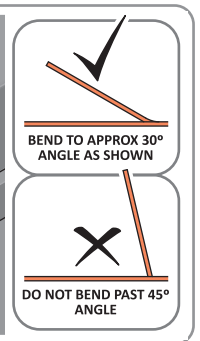

BEND TO APPROX 30°
ANGLE AS SHOWN

DO NOT BEND PAST 45°
ANGLE

ASSEMBLY STAGE 35

LOCATE AND SECURE ROOF PANEL SIDE 0212-05 ONTO LEFT-HAND SIDE OF SHED.

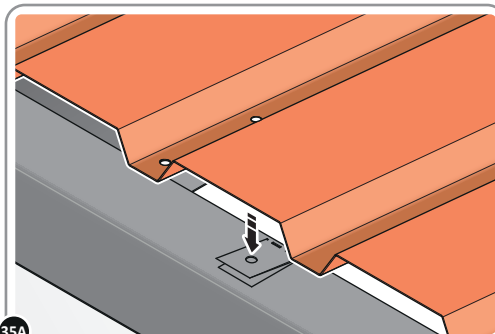
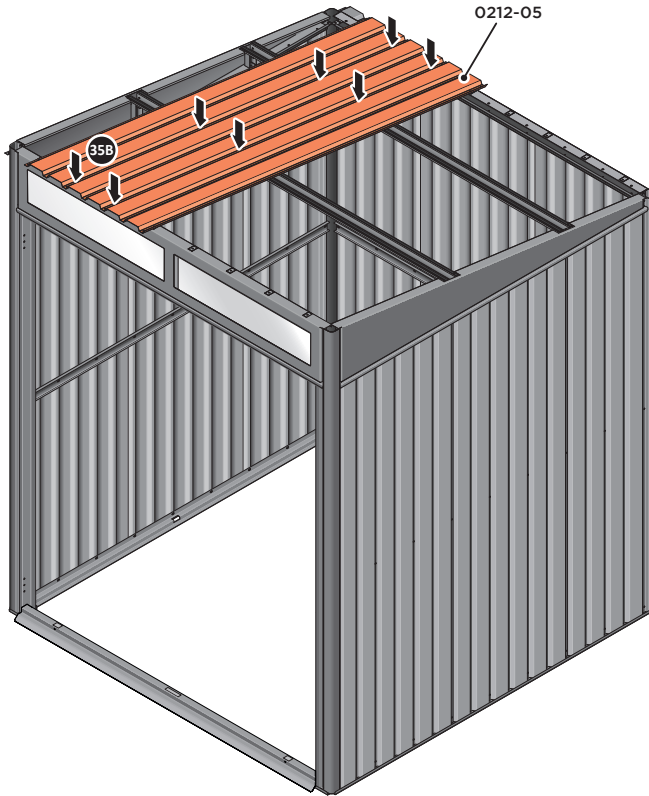

LOCATE A ROOF PANEL SIDE 0212-05 ALIGN WITH AIR BEND TABS AS INDICATED.

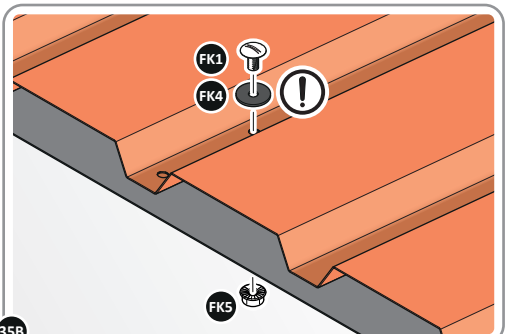

SECURE ROOF PANELS AT x8 LOCATIONS INDICATED USING TYPICAL FIXING METHOD. **IMPORTANT: ENSURE RUBBER WASHER FK4 IS LOCATED AS SHOWN.**

ASSEMBLY STAGE 36

LOCATE AND SECURE ROOF PANEL SIDE 0212-07 ONTO LEFT-HAND SIDE OF SHED.

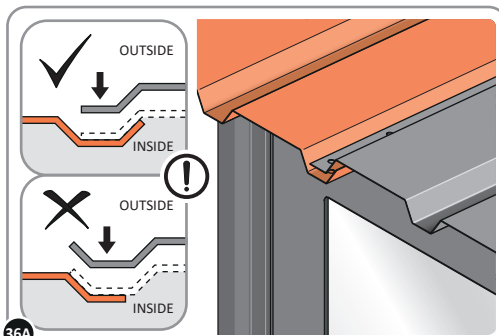
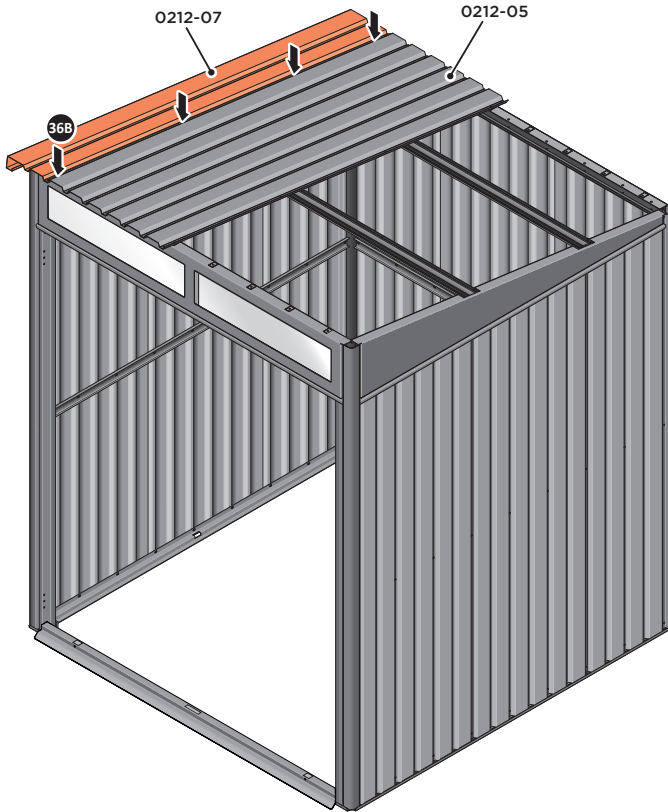

ALIGN AND OVERLAP ROOF PANEL 0205-07 WITH ROOF PANEL SIDE AS SHOWN.
IMPORTANT: ENSURE PANELS ALWAYS OVERLAP AS SHOWN.

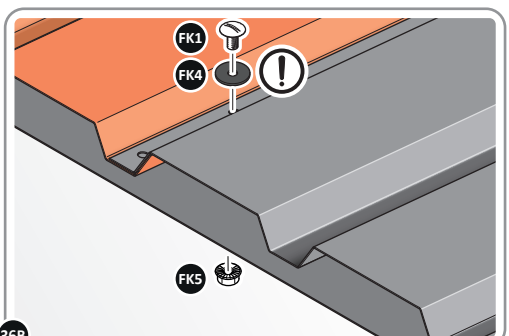

SECURE ROOF PANELS AT x 4 LOCATIONS INDICATED USING TYPICAL FIXING METHOD.
IMPORTANT: ENSURE RUBBER WASHER FK4 IS LOCATED AS SHOWN.

ASSEMBLY STAGE 37

LOCATE AND SECURE ROOF PANELS 0212-05.

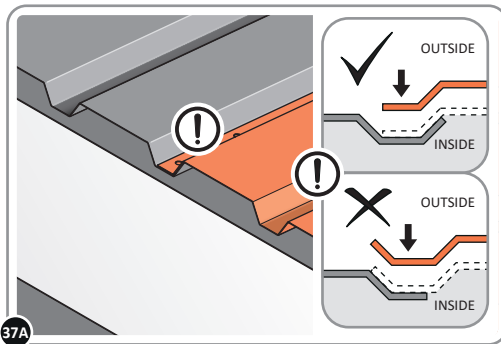
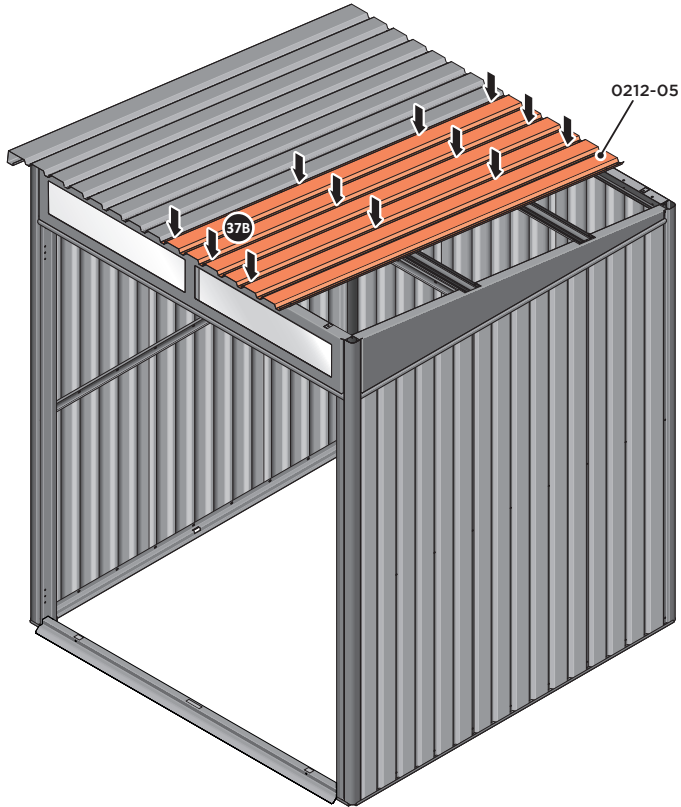

ALIGN AND OVERLAP ROOF PANEL 0212-05 WITH PREVIOUS ROOF PANEL.
IMPORTANT: ENSURE PANELS ALWAYS OVERLAP AS SHOWN.

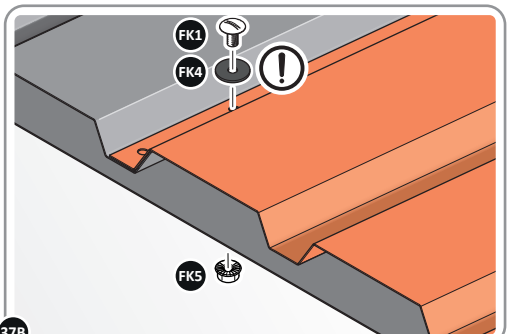

37B SECURE ROOF PANEL AT x12 LOCATIONS INDICATED USING TYPICAL FIXING METHOD.
IMPORTANT: ENSURE RUBBER WASHER FK4 IS LOCATED AS SHOWN.

ASSEMBLY STAGE 38

LOCATE ROOF PANEL SIDE 0212-07 ONTO RIGHT-HAND SIDE OF SHED.

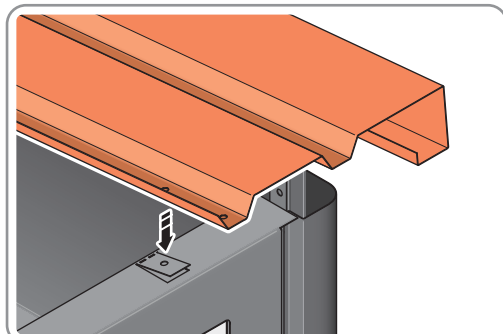
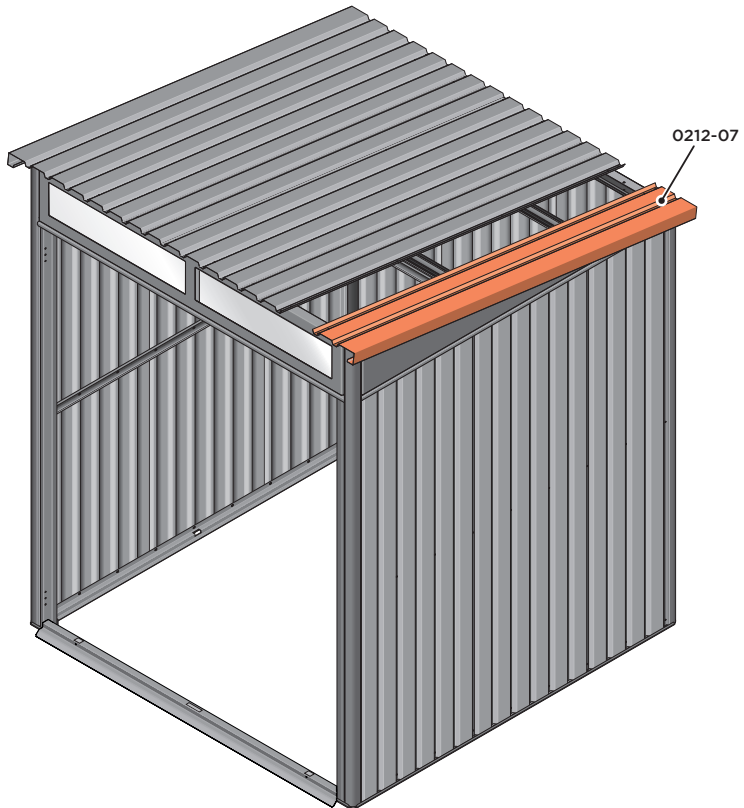

LOCATE A ROOF PANEL SIDE 0212-07 ONTO RIGHT-HAND SIDE OF SHED AND ALIGN WITH AIR BEND TABS AS INDICATED.

ASSEMBLY STAGE 39

LOCATE AND SECURE SMALL ROOF PANEL 0212-06.

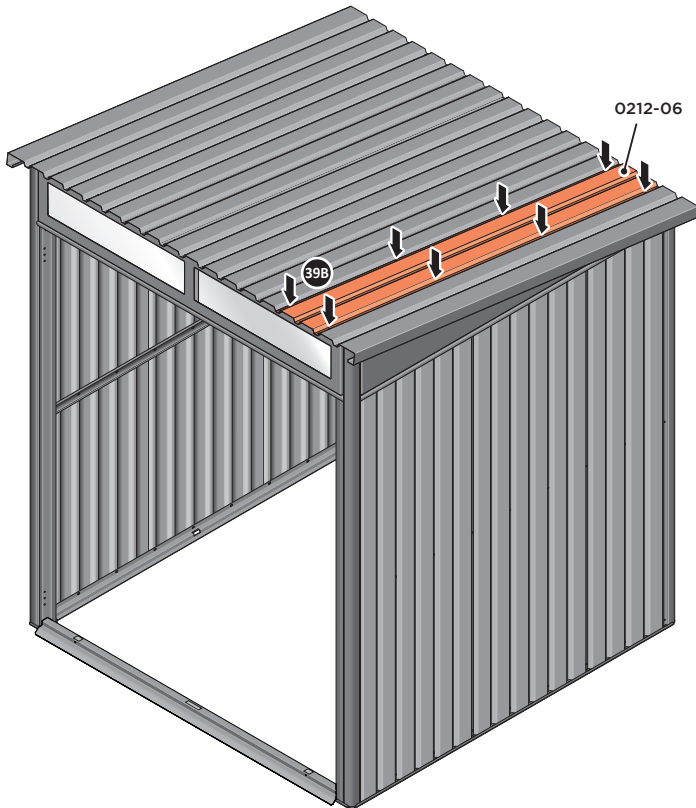

! UPON COMPLETION OF THIS PROCEDURE ENSURE STRUCTURE IS ALIGNED CORRECTLY AND TIGHTEN ALL FASTENERS

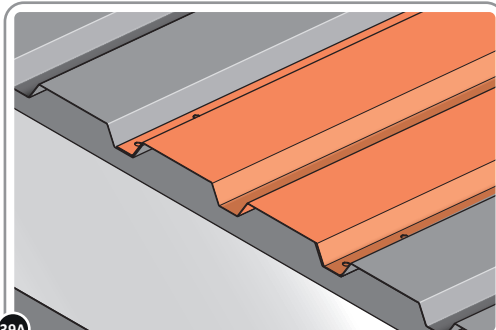

39A ALIGN AND OVERLAP SMALL ROOF PANEL 0212-06 WITH PREVIOUS ROOF PANEL AND ROOF PANEL SIDE.

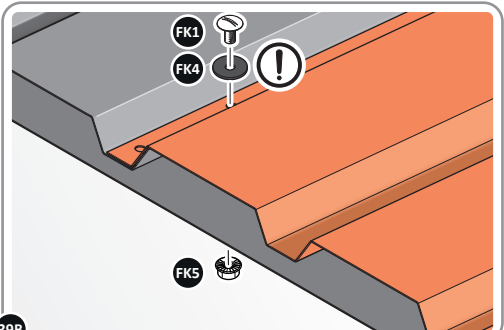

39B SECURE ROOF PANEL AT x8 LOCATIONS INDICATED USING TYPICAL FIXING METHOD. **IMPORTANT: ENSURE RUBBER WASHER FK4 IS LOCATED AS SHOWN.**

ASSEMBLY STAGE 40

LOCATE AND SECURE ROOF CAP 0215-03.

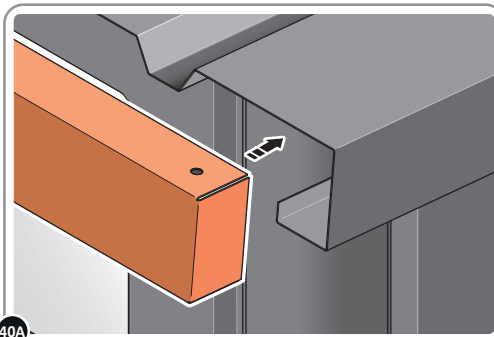
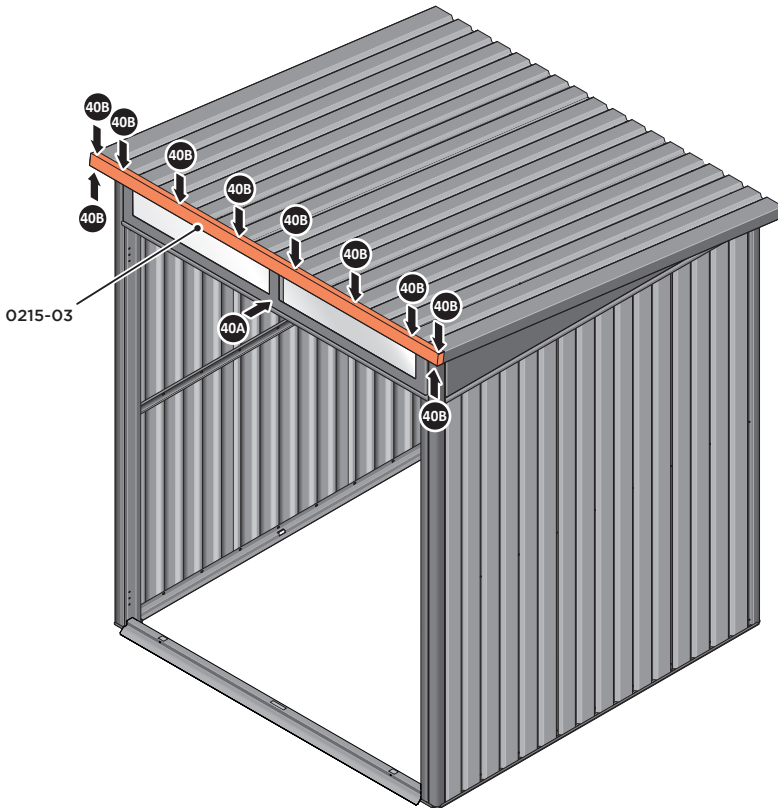

LOCATE ROOF CAP 0215-03 ONTO FRONT OF ROOF.

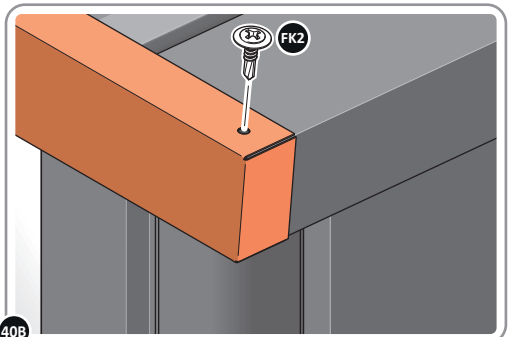

SECURE ROOF CAP AT x10 LOCATIONS INDICATED USING TYPICAL FIXING METHOD. PLEASE NOTE: THE FIXING USED IS A SELF DRILLING COMPONENT.

ASSEMBLY STAGE 41

LOCATE AND SECURE ROOF GUTTER 0215-05.

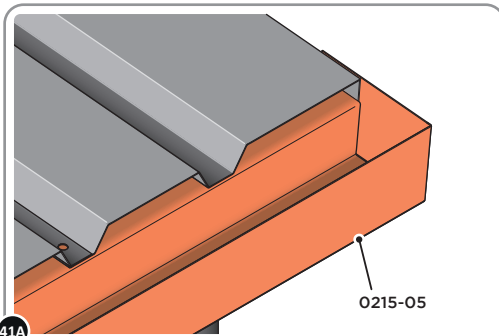
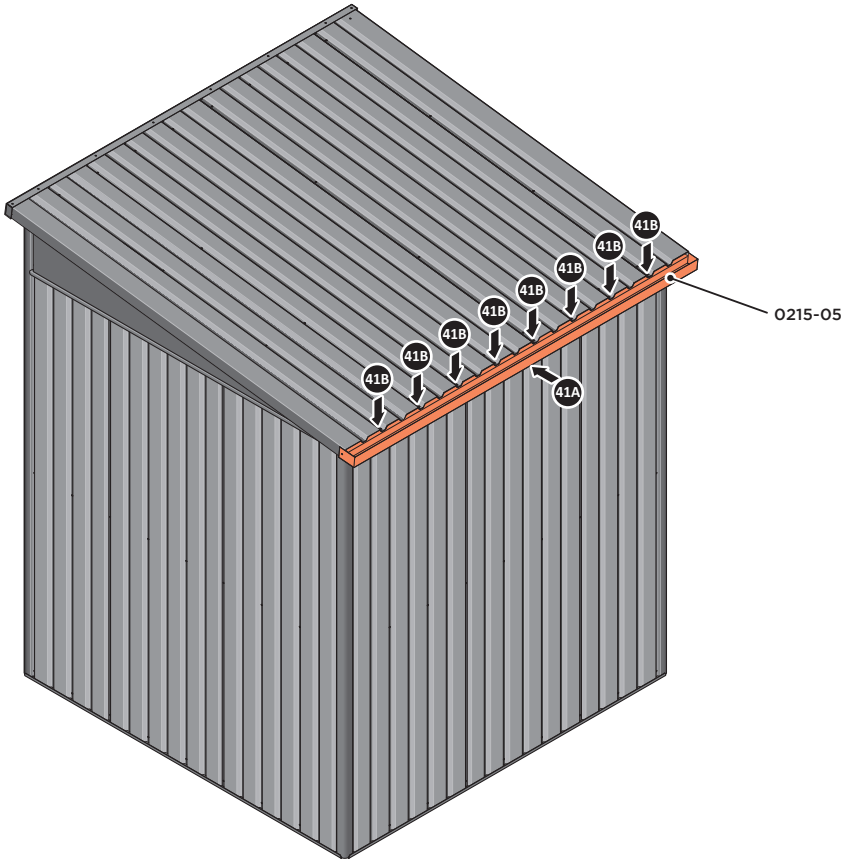

41A SLIDE ROOF GUTTER 0215-05 INTO POSITION AT THE REAR OF THE SHED ROOF.

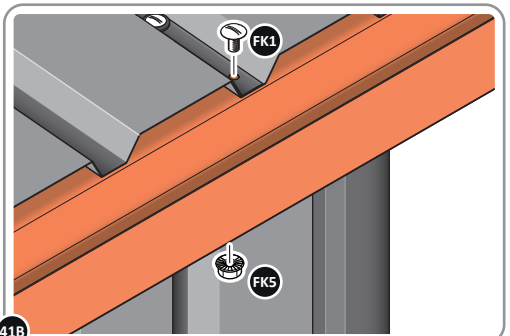

41B SECURE ROOF GUTTER AT x8 LOCATIONS INDICATED USING TYPICAL FIXING METHOD.

ASSEMBLY STAGE 42

LOCATE AND SECURE REAR ROOF CAP 0215-04.

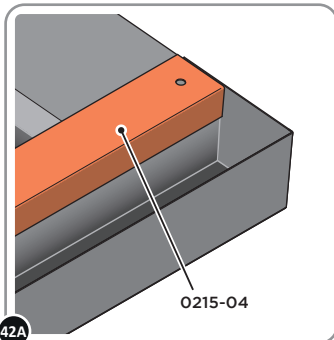
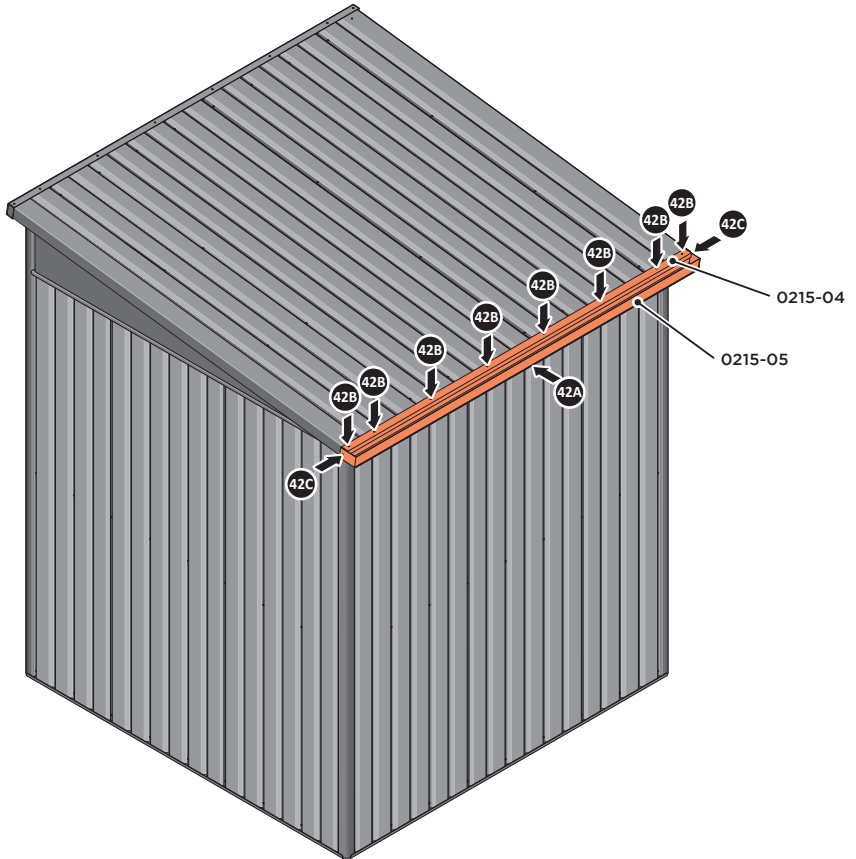

42A LOCATE REAR ROOF CAP 0215-04 ONTO REAR OF ROOF AS SHOWN ABOVE.

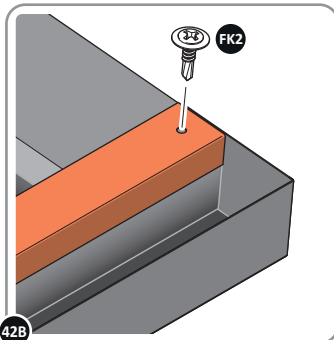

42B SECURE REAR ROOF CAP AT X8 LOCATIONS.

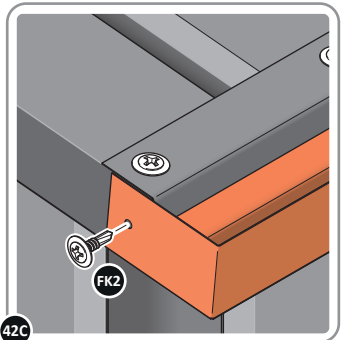

42C SECURE SLIDE ROOF GUTTER 0215-05 AT X2 LOCATIONS.

PLEASE NOTE: THE FIXING USED IS A SELF DRILLING COMPONENT.

ASSEMBLY STAGE 43

DETERMINE WHICH SIDE DRAIN HOLE 0205-53 WILL BE LOCATED.

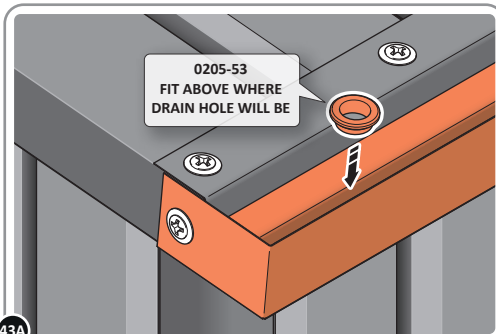
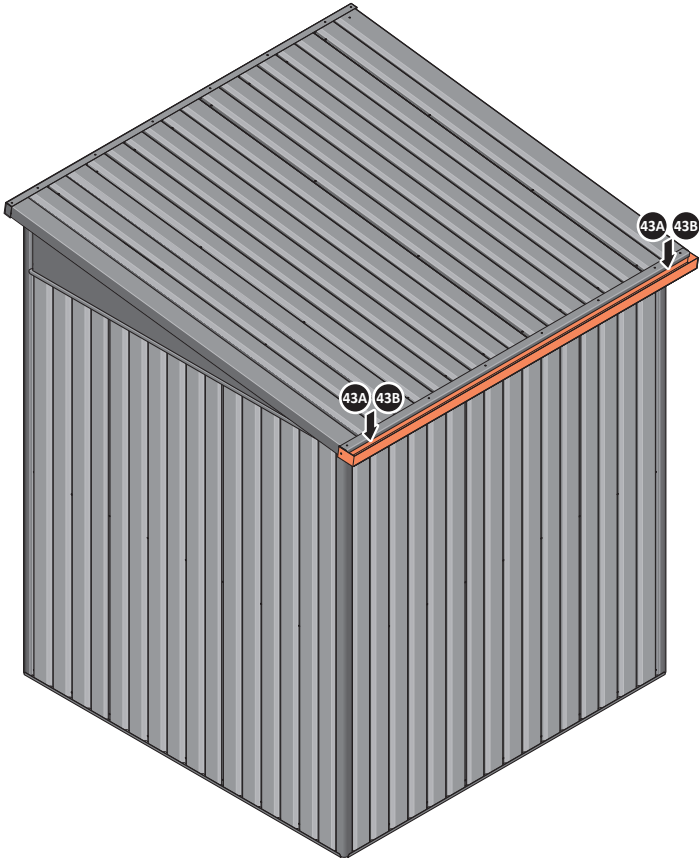

43A

LOCATE AN OPEN GROMMET INTO THE ROOF GUTTER ABOVE WHERE THE DRAIN HOLE WILL BE LOCATED.

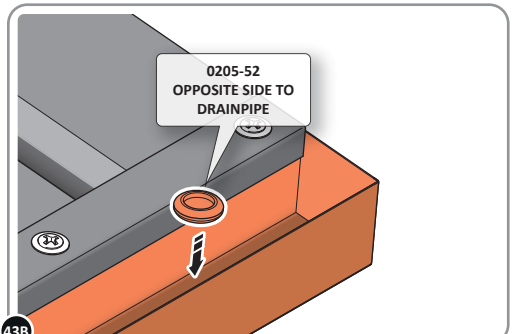

43B

LOCATE CLOSED GROMMET INTO THE ROOF GUTTER ON THE OPPOSITE SIDE TO THE LOCATED DRAIN HOLE AS SHOWN ABOVE.

ASSEMBLY STAGE 44

LOCATE AND SECURE RIGHT-HAND DOOR ASSEMBLY 0205-36 FURNITURE.

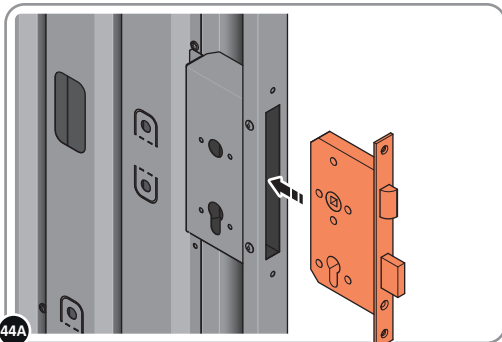
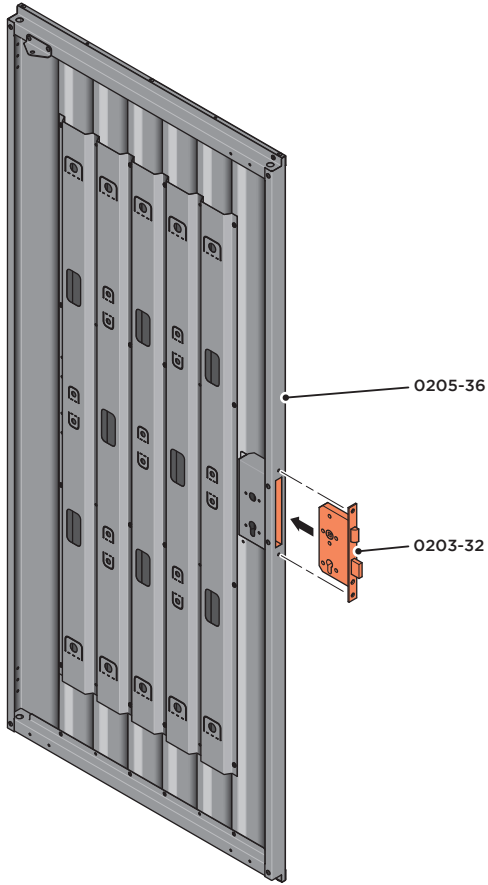

LOCATE EURO MORTICE LOCK 0203-32 RIGHT-HAND DOOR APERTURE AS SHOWN.

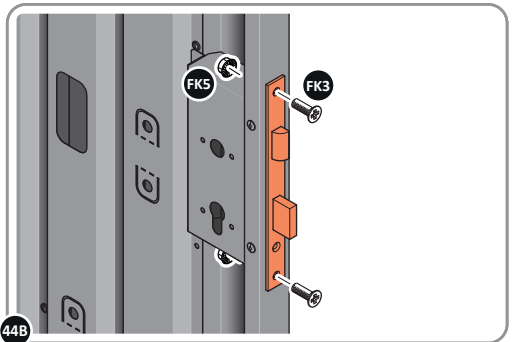

SECURE EURO MORTICE LOCK 0203-32 AT X2 LOCATIONS INDICATED ABOVE.

SEE FOLLOWING DATA SHEET FOR COMPLETION OF MORTICE LOCK INSTALLATION

ASSEMBLY STAGE 44 CONTINUED

LOCATE AND SECURE RIGHT-HAND DOOR ASSEMBLY 0205-36 FURNITURE.

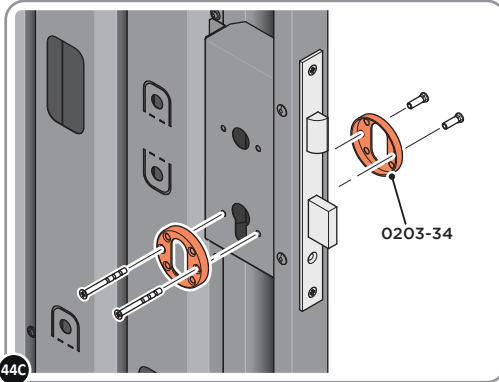

LOCATE AND SECURE EURO ESCUTCHEON 0203-34 AS SHOWN.

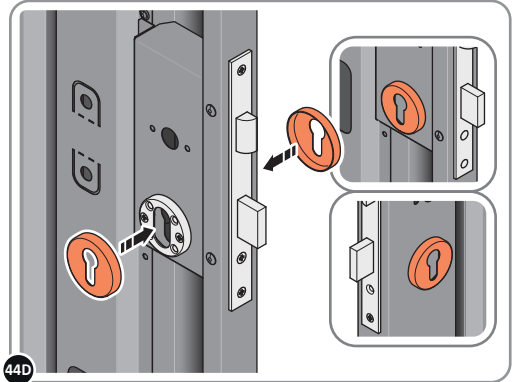

LOCATE EURO ESCUTCHEON COVER 0203-34 ONTO EURO ESCUTCHEON AS SHOWN.
PLEASE NOTE: THESE ARE PUSHED ON AND WILL CLICK INTO PLACE.

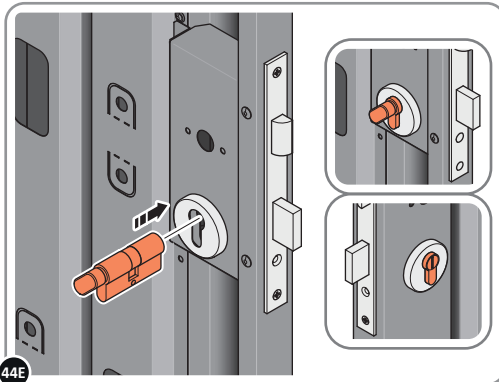

LOCATE EURO CYLINDER 0203-36 INTO DOOR APERTURE.
IMPORTANT: ENSURE COVER IS FITTED AS SHOWN.

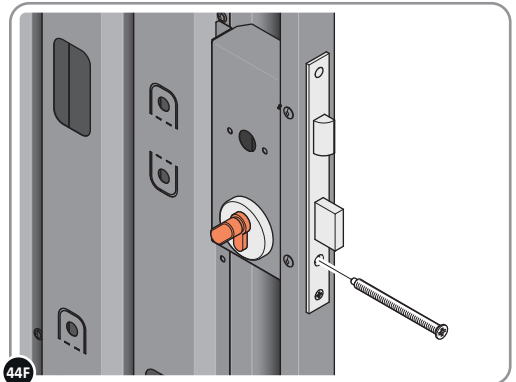

SECURE EURO CYLINDER 0203-36 AS SHOWN ABOVE.
PLEASE NOTE: FIXING IS PART OF THE EURO MORTICE LOCK ASSEMBLY.

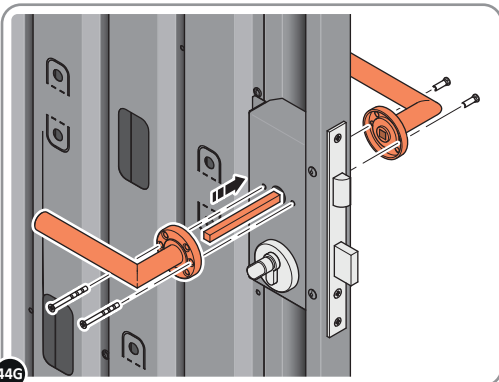

LOCATE AND SECURE DOOR HANDLE ASSEMBLY 0203-33 AS SHOWN.

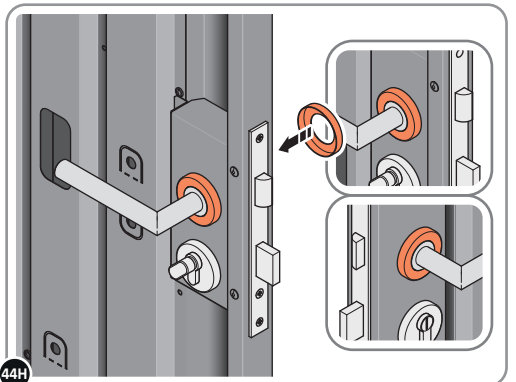

LOCATE COVER ONTO DOOR HANDLE AS SHOWN.
PLEASE NOTE: THESE ARE PUSHED ON AND WILL CLICK INTO PLACE.

ASSEMBLY STAGE 45

LOCATE AND SECURE LEFT-HAND DOOR ASSEMBLY 0205-37 FURNITURE.

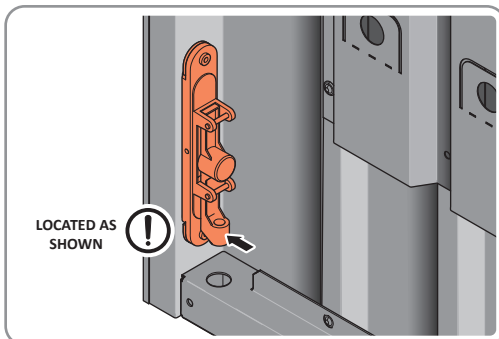
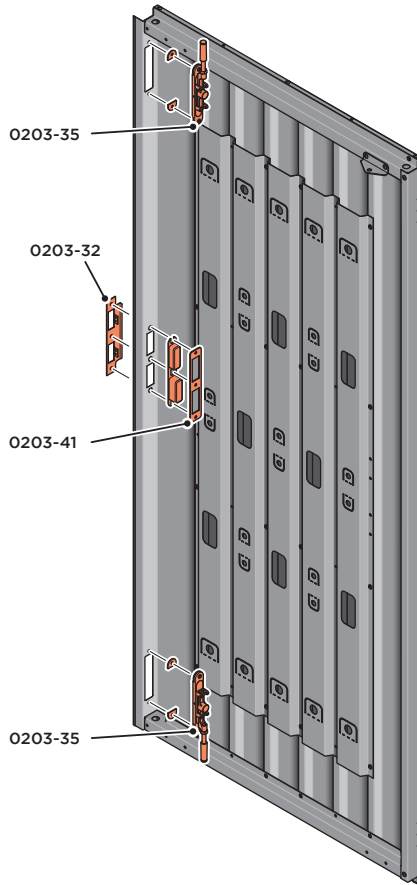

ENSURE THE PLUNGER INDICATED IS FACING THE BOTTOM OF THE DOOR, LOCATE AS SHOWN ABOVE AND SECURE USING ADJACENT FIXING METHOD.

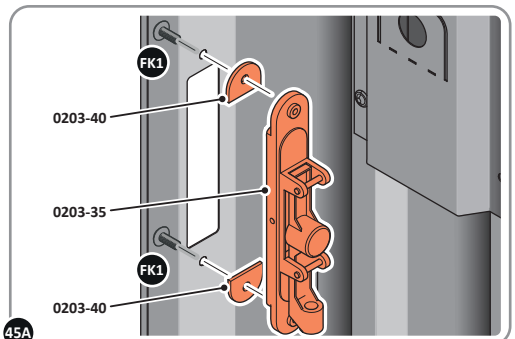

SECURE EACH FLUSH DOOR BOLT ENSURING PLATE PACKER 0203-40 IS LOCATED AS SHOWN ABOVE.

ASSEMBLY STAGE 45 CONTINUED

LOCATE AND SECURE LEFT-HAND DOOR ASSEMBLY 0205-37 FURNITURE.

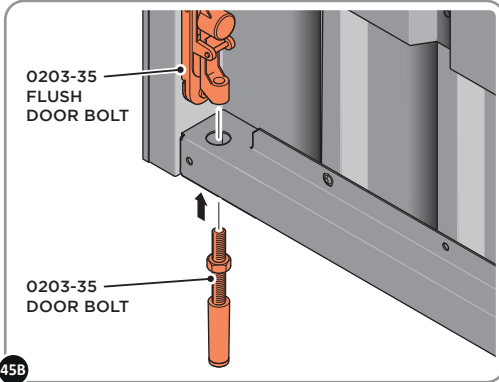

45B ATTACH DOOR BOLT ONTO FLUSH DOOR BOLT.

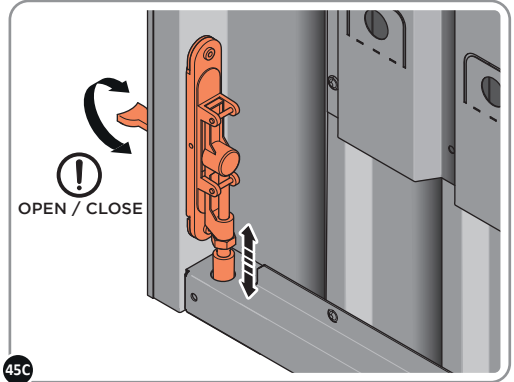

45C ENSURE FLUSH DOOR BOLT OPENS AND CLOSES.

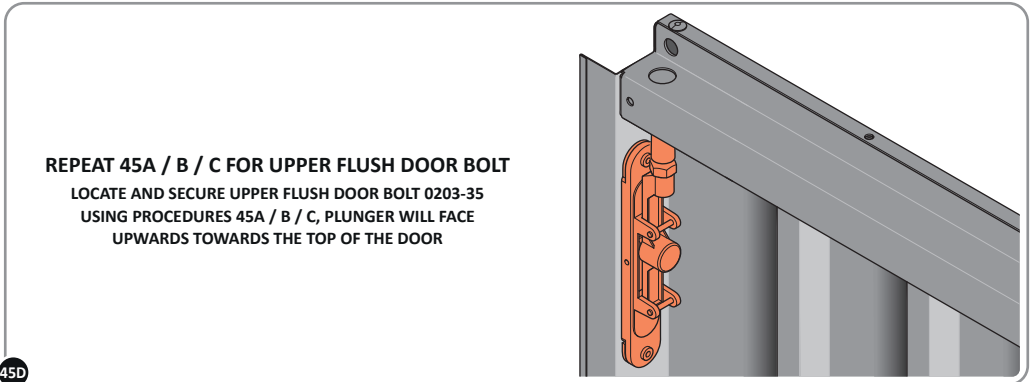

45D

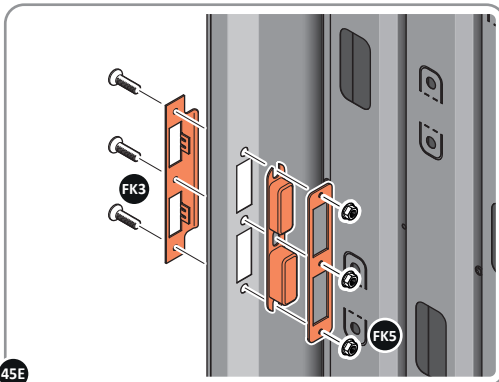

45E LOCATE AND SECURE EURO MORTICE LOCK 0203-32 AND CATCH PLATE COVER 0203-41 AS SHOWN ABOVE.

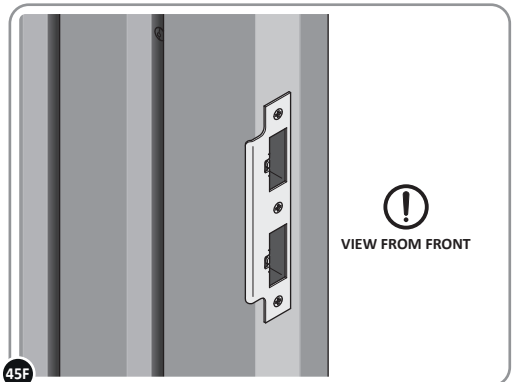

45F SECURED EURO MORTICE LOCK 0203-32 AS SEEN FROM FRONT.

Assembly Guide

ASSEMBLY STAGE 46

LOCATE AND SECURE A DOOR GROMMET 0203-57 AT EACH LOCATION INDICATED.

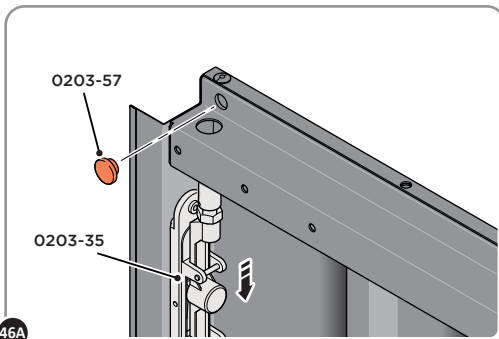
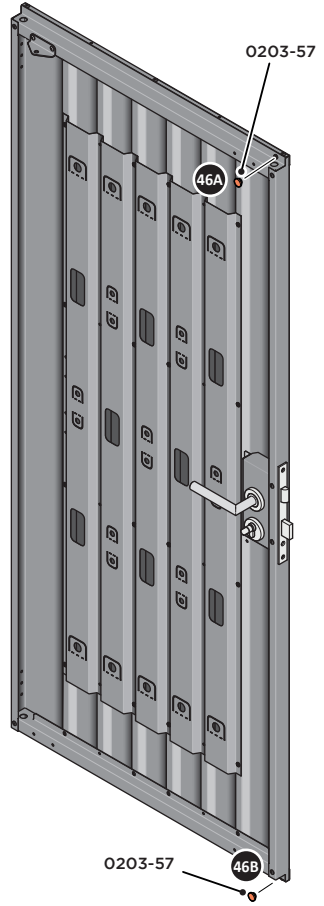

46A

LOCATE DOOR GROMMET 0203-57 AT x2 LOCATIONS INDICATED.
PLEASE NOTE: 0203-35 FLUSH BOLTS ARE ALL IN THE UNLOCKED POSITIONS.

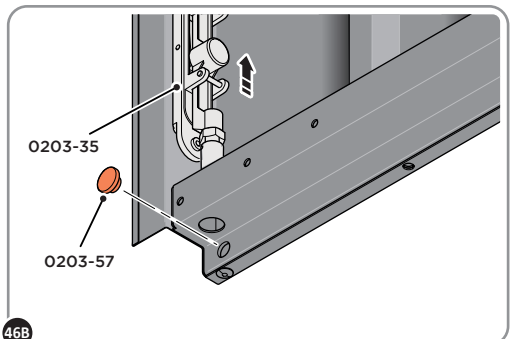

46B

LOCATE DOOR GROMMET 0203-57 AT x2 LOCATIONS AS SHOWN.
PLEASE NOTE: THESE ARE PUSHED ON AND WILL CLICK INTO PLACE.

Assembly Guide

ASSEMBLY STAGE 47

LOCATE AND SECURE DOOR HINGES ONTO DOOR ASSEMBLIES.

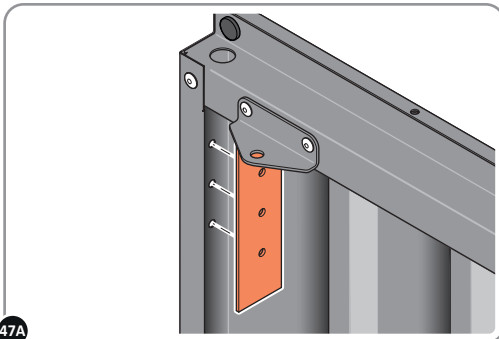
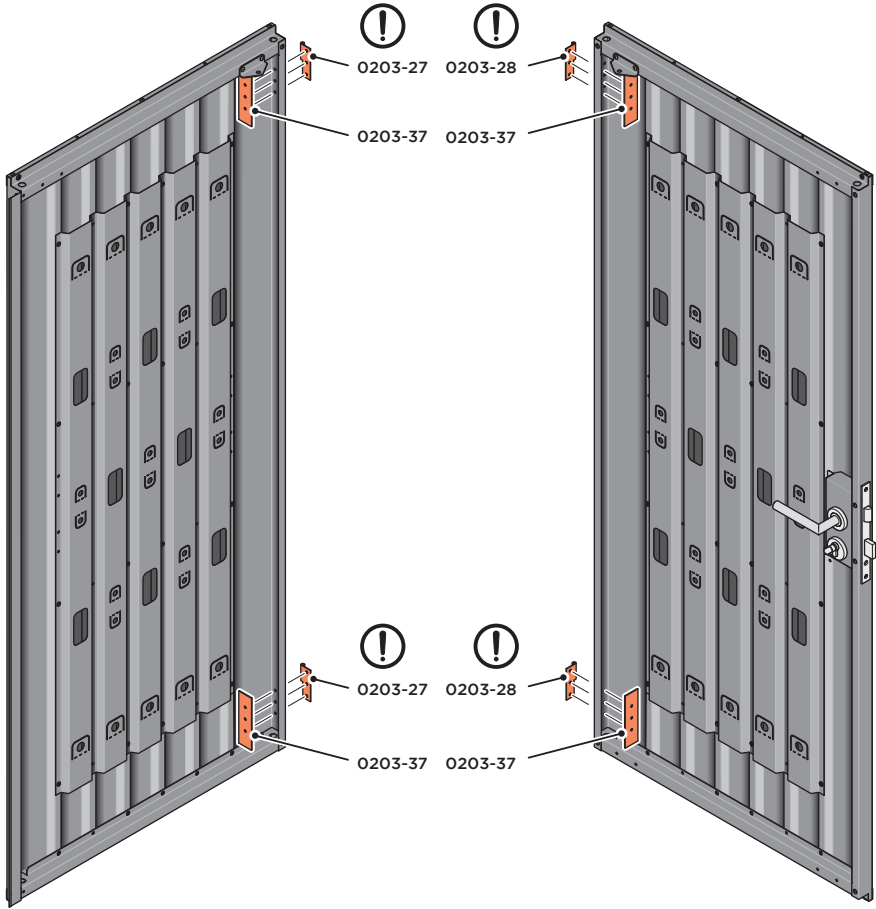

47A

LOCATE DOOR HINGE PLATE 0203-37 WITHIN DOOR AS SHOWN.

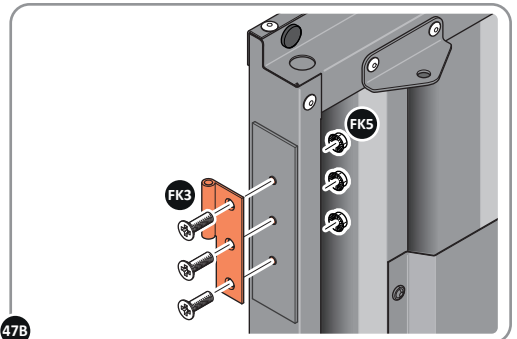

47B

SECURE DOOR HINGE PLATE AND HINGE 0203-27 AND 0203-28 AS SHOWN.
IMPORTANT: ENSURE CORRECT DOOR HINGE IS SECURED TO CORRECT DOOR.

Assembly Guide

ASSEMBLY STAGE 48

LOCATE AND SECURE DOOR HINGE 0203-27 & PLATE 0203-39 ONTO LEFT-HAND DOOR POST.

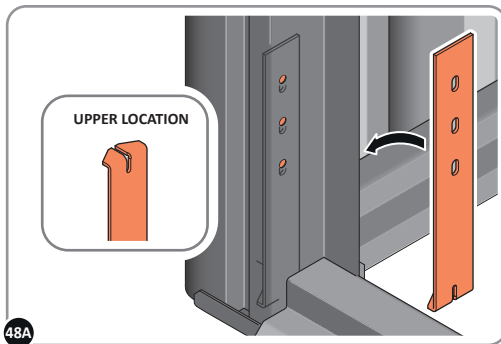
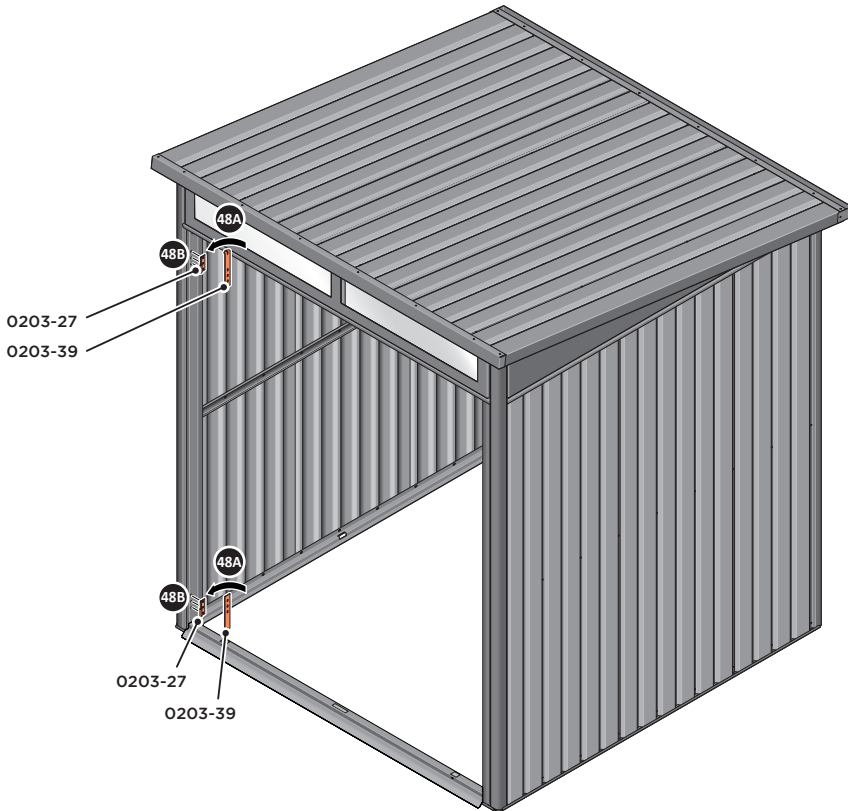

LOCATE DOOR POST PLATE 0203-39 WITHIN DOOR FRAME AS SHOWN.
IMPORTANT: SLOT WITH FACE UPWARDS AT UPPER LOCATION.

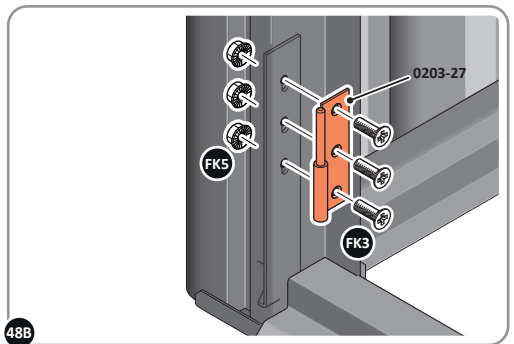

SECURE DOOR POST PLATE AND LEFT-HAND HINGE 0203-27 AS SHOWN.
PLEASE NOTE: REPEAT EACH PROCEDURE FOR UPPER LOCATION.

ASSEMBLY STAGE 49

LOCATE AND SECURE DOOR HINGE 0203-28 & PLATE 0203-39 ONTO RIGHT-HAND DOOR POST.

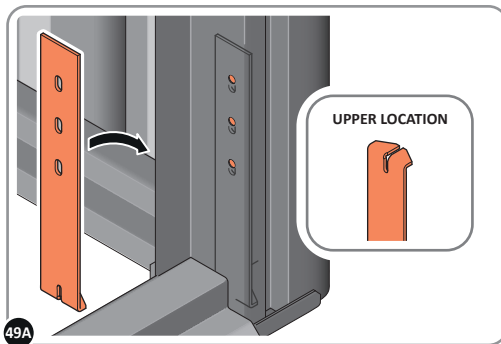
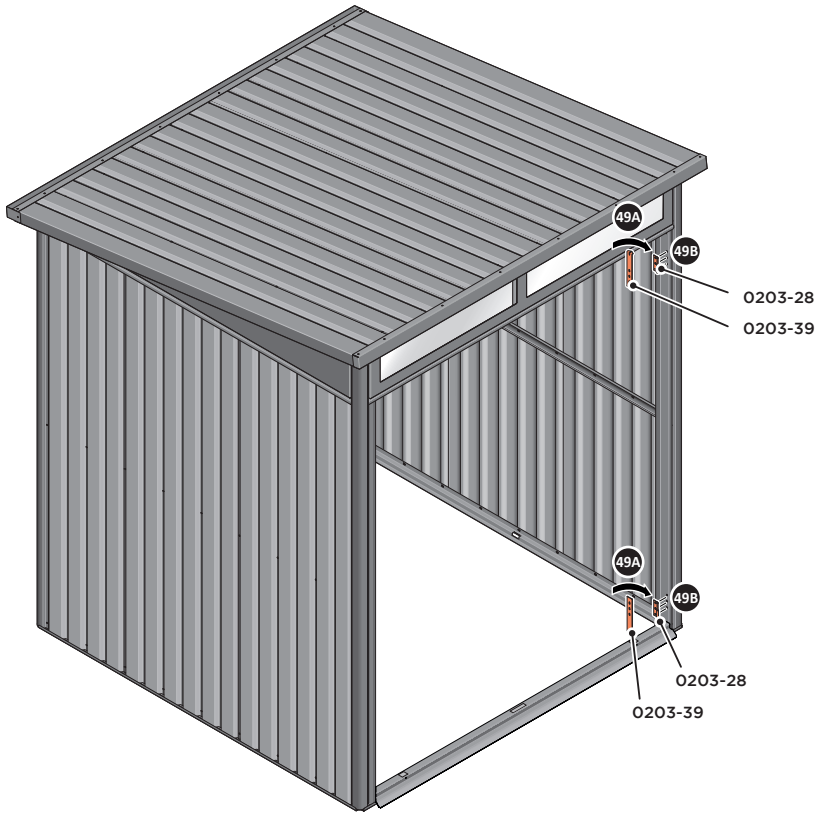

LOCATE DOOR POST PLATE 0203-39 WITHIN DOOR FRAME AS SHOWN. IMPORTANT: SLOT WITH FACE UPWARDS AT UPPER LOCATION.

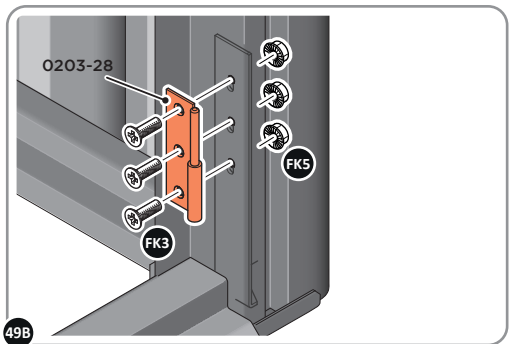

SECURE DOOR POST PLATE AND RIGHT-HAND HINGE 0203-28 AS SHOWN. PLEASE NOTE: REPEAT EACH PROCEDURE FOR UPPER LOCATION.

Assembly Guide

ASSEMBLY STAGE 50

LOCATE AND SECURE GAS STRUT BRACKETS 0205-66.

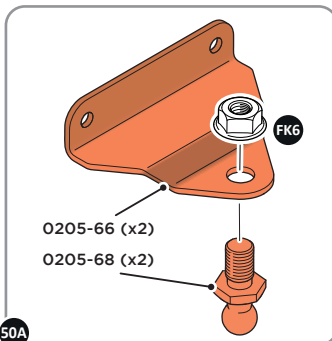
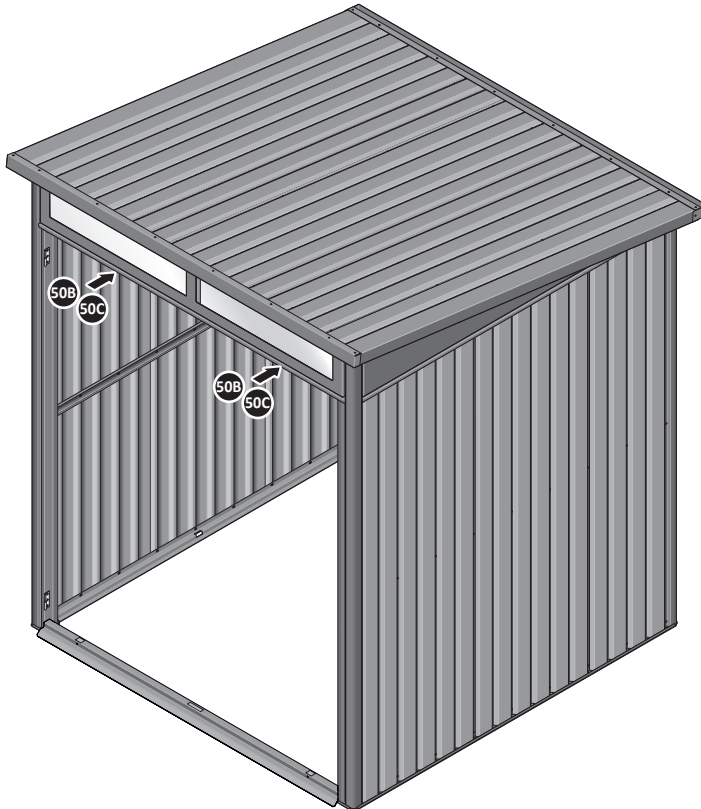

50A

SECURE A GAS STRUT BALL JOINT 0205-68 ONTO EACH GAS STRUT BRACKET 0205-66.

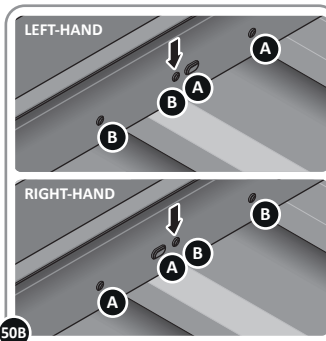

50B

DETERMINE DOOR OPENING ANGLE:
A: 90° OPENING OR B: 120° OPENING

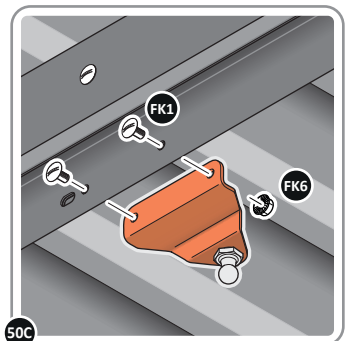

50C

ALIGN EACH GAS STRUT BRACKET WITH RELEVANT FIXING HOLES, SECURE USING TYPICAL FIXING METHOD ABOVE.

ASSEMBLY STAGE 51

LOCATE DOOR ASSEMBLIES ONTO HINGES.

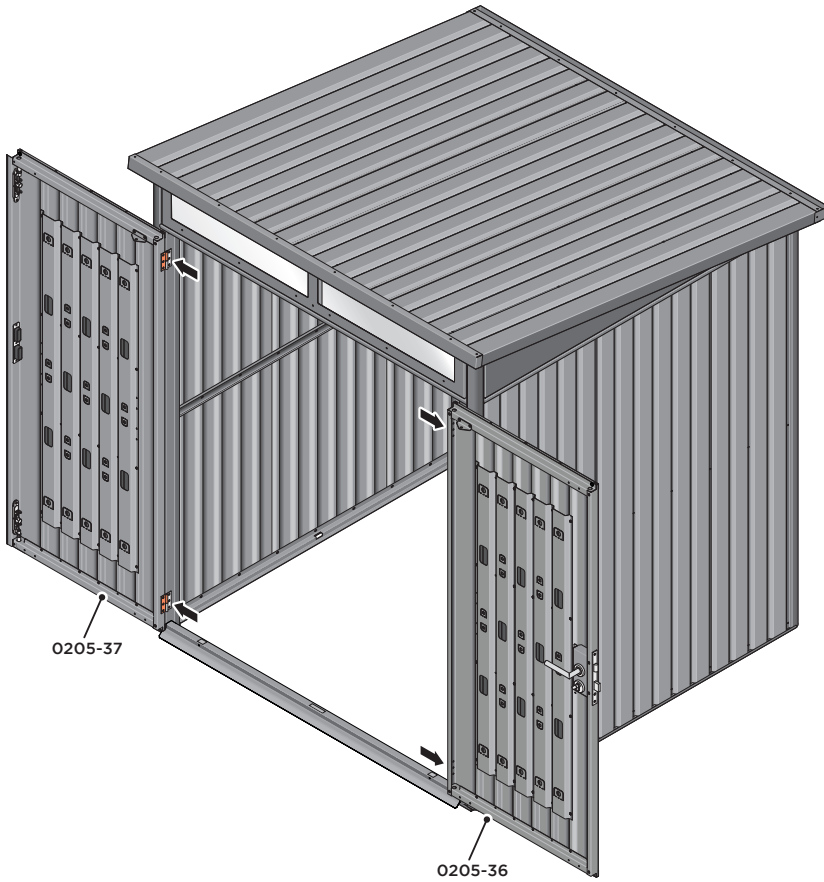

SLIDE EACH DOOR ASSEMBLY ONTO EACH OF THEIR RESPECTIVE HINGES.

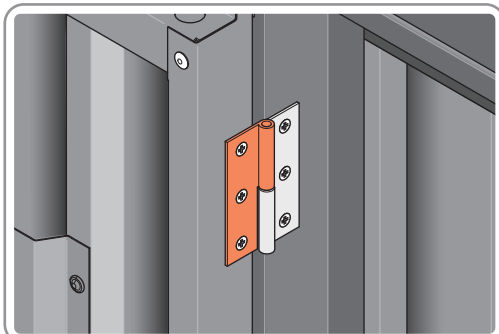

ASSEMBLED DOOR HINGE.

ASSEMBLY STAGE 52

LOCATE AND SECURE GAS STRUT 0205-63 .

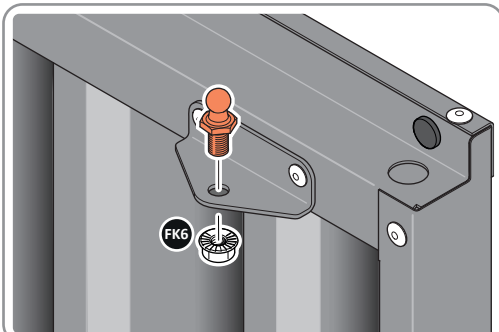
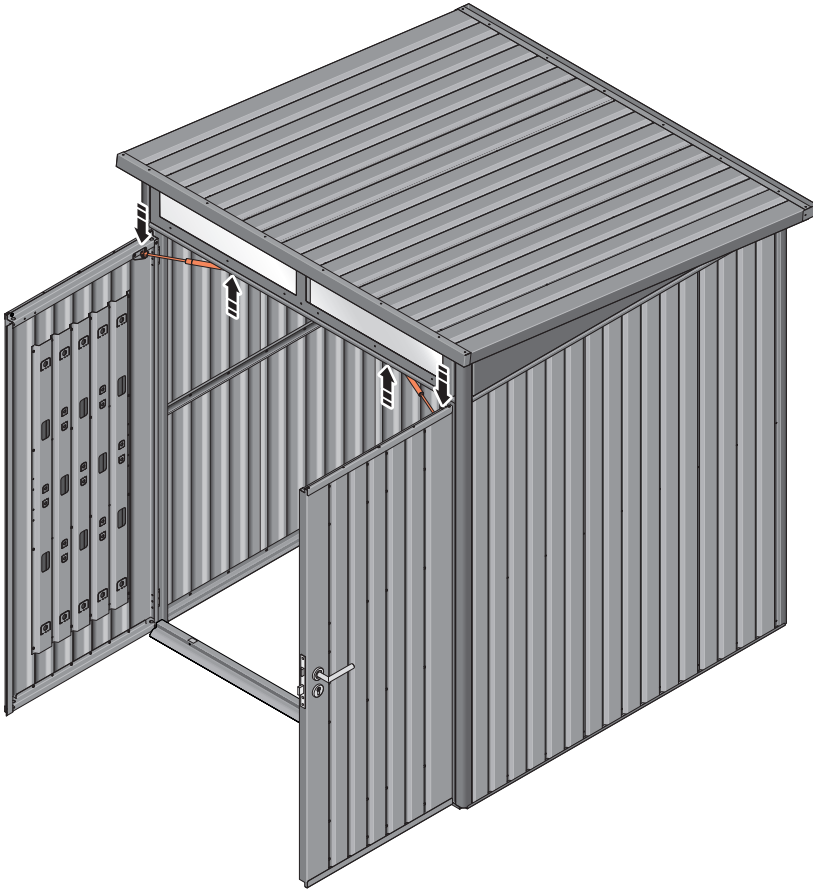

SECURE A GAS STRUT BALL JOINT 0205-68 ONTO EACH GAS STRUT BRACKET THAT IS PRE-RIVETED ONTO EACH DOOR ASSEMBLY.

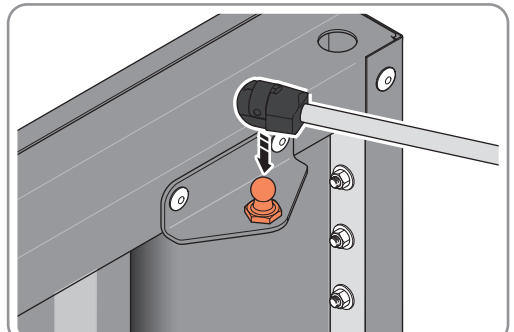

FIX EACH GAS STRUT 0205-63 ONTO RELEVANT GAS STRUT BALL JOINTS.
PLEASE NOTE: PUSHES DOWN ON DOOR AND UPWARDS ON DOOR FRAME.

ASSEMBLY STAGE 53

LOCATE AND SECURE SHELF ASSEMBLY 0205-38.

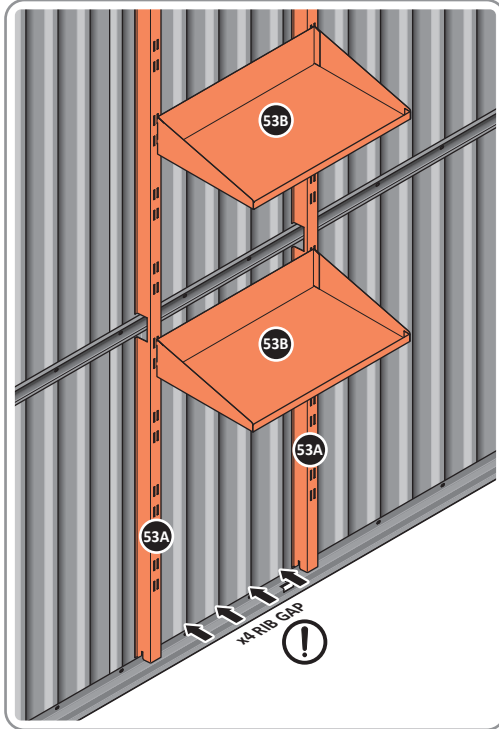

THE SHELF ASSEMBLY CAN BE LOCATED AS DESIRED, PLEASE DETERMINE THE MOST SUITABLE LOCATION AND ASSEMBLE AS SHOWN IN FIG. 53A & 53B.

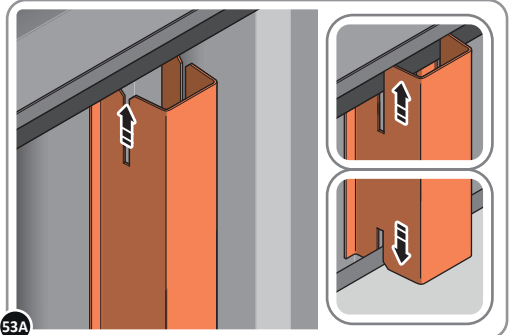

SLIDE SHELF POST UP INTO ROOF FRAME, ONCE THERE IS ENOUGH CLEARANCE AT THE BOTTOM LOCATE SHELF POST OVER FLOOR FRAME AND LOWER.

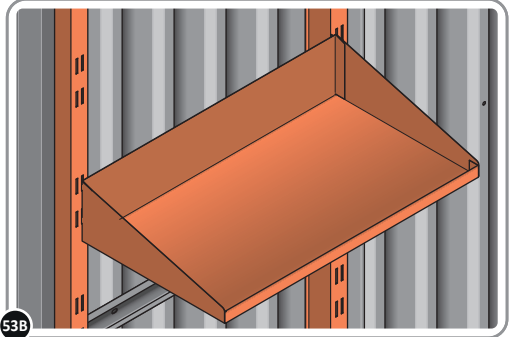

LOCATE EACH SHELF 0205-38-02 ONTO SHELF POST AS DESIRED. PLEASE NOTE: THE SHELF SIMPLY HOOKS ONTO THE POST.

ASSEMBLY STAGE 54

LOCATE TOOL HANGERS 0205-39 WITHIN SHED AS DESIRED LOCATION.

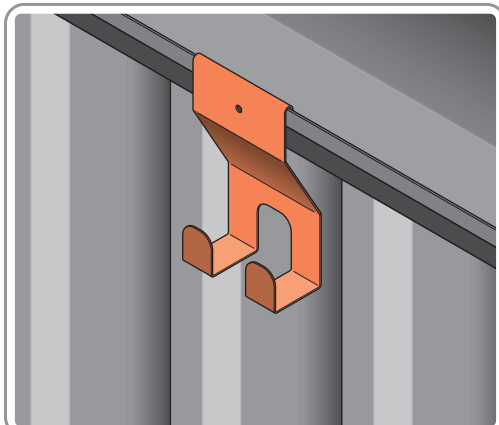

HOOK EACH TOOL HANGER 0205-39 ONTO ROOF FRAME AT DESIRED LOCATION.



IMPORTANT

ADJUST ALL COMPONENTS FOR BEST POSSIBLE FIT AND TIGHTEN ALL FASTENERS.

ONCE ALL FASTENERS HAVE BEEN CHECKED AND ARE SECURE THE ASSEMBLY IS COMPLETE

WE RECOMMEND YOU ANCHOR YOUR SHED TO A SOLID CONCRETE BASE, GUIDANCE CAN BE FOUND ON PAGE 'I'

NOTES

A series of horizontal dashed lines for taking notes, consisting of 22 lines spaced evenly across the page.

Caring for your Stone Garden Lifestyle product

Your **Stone Garden Lifestyle** product is designed to stand the test of time, which is why we're happy to offer a **25 year warranty** on our products. With zero maintenance required, simply assemble your **Stone Garden Lifestyle** product and enjoy putting it to great use in your garden.

Periodically, you might want to give your product a clean, these simple care tips are not essential to the performance of your product:

- Remove surface dirt with plain water using a jet wash or sponge, the coating on our products will ensure dirt.
- If you've purchased a **Stone Garden Lifestyle** metal storage solution, periodically clear the roof of fallen leaves.
- If your product has guttering, remove leaves and garden debris as you would on your home. or mud simply wipes away.

IMPORTANT: PLEASE REGISTER YOUR STONE GARDEN LIFESTYLE PRODUCT BEFORE ASSEMBLY



Doc Ref: 808-3136E Rev.A

Ensure you have registered your Stone Garden Lifestyle product

Using the unique serial number found on the cover of this document, please visit
<https://bit.ly/StoneGardenWarranty>
to register your product and access the 25 year warranty.