

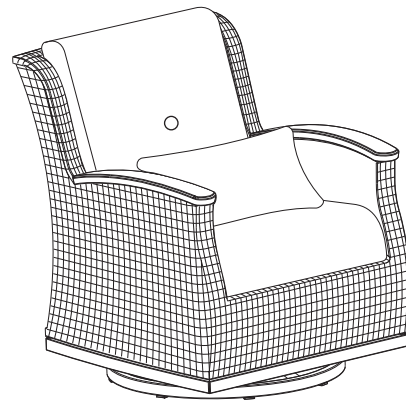

# 5 Piece Woven Seating

## Set with Fire

### CARE INSTRUCTIONS

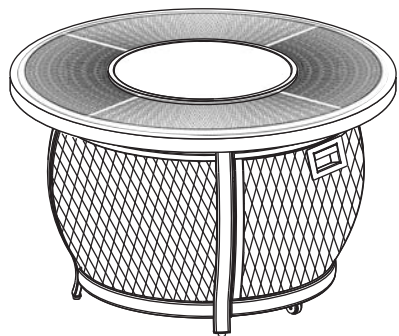

ITM. / ART. 449874

**IMPORTANT, RETAIN FOR FUTURE REFERENCE:  
READ CAREFULLY**

#### Missing parts or damaged parts?

Please call our Customer Service Center or contact Agio via email

**US & Canada : 1-888-383-1932 Email: [customerservice@agio-usa.com](mailto:customerservice@agio-usa.com)**

9:00AM - 5:00PM Eastern Time, Monday - Friday

#### International Regions:

Please visit <http://www.agio-usa.com/service-center/costco-international/>

or contact Agio via email at [customerservice@agio-usa.com](mailto:customerservice@agio-usa.com)

For additional support on care and maintenance of your Agio outdoor furniture please visit our website at:

[www.agio-usa.com/service-center/maintenance/](http://www.agio-usa.com/service-center/maintenance/)

#### Special Warnings:

THIS ITEM IS INTENDED FOR OUTDOOR DOMESTIC USE ONLY.

NOT FOR COMMERCIAL USE.

#### Agio International Corporation

900 E. Hamilton Avenue,  
Suite 100, Campbell,  
CA 95008, USA



## FRAMES

**Cleaning** - Use mild soap and warm water. Do not use abrasive materials, cleaners, or bleach products. Rinse with clean water and dry thoroughly.

**Maintenance** - Periodically clean and dry thoroughly. Be sure to drain any water accumulated inside the frames. To thoroughly drain frames, remove foot caps and tilt the frames, if necessary, to remove all water. This is critical. Water allowed to accumulate inside the frames and then exposed to sub-freezing temperatures can cause damage to the frame tubing. Such damage is not covered under warranty. Always clean, drain, and dry thoroughly before storing for the winter. For best results, always store or cover your furniture when not in use.

\*\* When cleaning or moving large or heavy items, always have two people work together. Never drag furniture.



## FABRICS (CUSHIONS/SLINGS)

**Cleaning** - Sunbrella® fabric should be cleaned regularly. Brush off any loose dirt and wash with a mild soap and lukewarm water solution. For stubborn stains and mildew, wash with a solution of 236.6 ml / 1 cup of bleach and 59.2 ml / 0.25 cup of mild soap per 3.79L / 1 gallon of water. Rinse thoroughly to remove soap. Allow fabric to air dry.

**Maintenance** - The best way to maintain the beauty of cushions and slings is to store them in a dry area and out of the elements when not in use, or cover with commercially available outdoor furniture covers.



## COVERS

Furniture covers are a great way to protect your set from harsh elements of weather and UV light. However, it is important to ensure furniture and covers are free of moisture and debris before covering. It is also necessary to promptly uncover furniture after rain and during periods of high humidity to prevent moisture build up. Failure to do so can lead to permanent surface and finish damage.

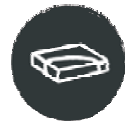

## CUSHIONS

To ensure longevity of your patio set each seat cushion is made with high density foam. With initial use the seat cushions may feel firm, but with continued use the cushions will continue to soften and provide the ultimate comfort for seasons to come.

Cushions can become water saturated with heavy water exposure. To allow cushions to air-dry properly, follow the suggested steps:

- Unzip cushion cover to ventilate and facilitate the drying process. Do not remove cushion covers.
- Place cushions upright for faster drainage. Ventilation zipper should be facing down.
- Store cushions indoors during rainy seasons and inclement weather.



## Ensemble de patio avec table-brasero 5 Pièces

### INSTRUCTIONS DE D'ENTRETIEN

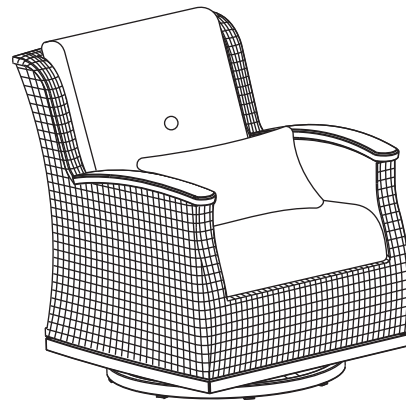
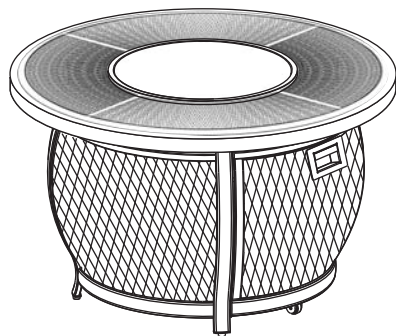

ITM. / ART. 449874

**IMPORTANT, À CONSERVER POUR DE FUTURS BESOINS DE  
RÉFÉRENCE: À LIRE SOIGNEUSEMENT**

#### **Des pièces manquent ou sont endommagées?**

Veillez communiquer avec notre service à la clientèle

**Au Canada et aux États-Unis, téléphoner au 1-888-383-1932**

**ou envoyer un courrier électronique à [customerservice@agio-usa.com](mailto:customerservice@agio-usa.com).**

9 h à 17 h (HNE) DU LUNDI AU VENDREDI.

#### **Régions internationales :**

Veillez visiter <http://www.agio-usa.com/service-center/costco-international/>  
ou contacter via l'adresse courriel [customerservice@agio-usa.com](mailto:customerservice@agio-usa.com).

Pour un soutien vidéo additionnel à l'assemblage, pour  
résoudre des problèmes ou pour l'entretien du matériel de  
patio agio, se rendre sur notre site web :

[www.agio-usa.com/service-center/maintenance/](http://www.agio-usa.com/service-center/maintenance/)(en anglais seulement)

#### **Avertissements spéciaux!**

CET ARTICLE EST CONÇU POUR UNE UTILISATION DOMESTIQUE À  
L'EXTÉRIEUR SEULEMENT.

NON CONÇU POUR UNE UTILISATION COMMERCIALE.

#### **Agió International Corporation**

900 E. Hamilton Avenue,  
Suite 100, Campbell,  
CA 95008, USA



## CADRES

**Nettoyage** : utiliser un savon doux et de l'eau tiède. Ne pas utiliser d'abrasifs, de détergents, ou d'agents de blanchiment. Rincer à l'eau claire et bien sécher.

**Entretien** : périodiquement, nettoyer et sécher soigneusement. Bien drainer toute l'eau accumulée dans les cadres. Pour ce faire, enlever le capuchon de pattes et incliner les cadres, si nécessaire, pour en faire sortir toute l'eau. Ceci est très important. L'eau qui s'accumule dans les cadres, puis est exposée à des températures sous zéro, peut endommager les tubes des cadres. De tels dommages ne sont pas couverts par la garantie. Toujours nettoyer, drainer et sécher soigneusement avant d'entreposer pour l'hiver. Pour de meilleurs résultats, toujours entreposer ou recouvrir le mobilier qui n'est pas utilisé. Il est recommandé que deux personnes nettoient ou bougent les articles lourds ou encombrants. Ne jamais traîner le mobilier.



## TISSUS (COUSSINS/LANIÈRES)

Le tissu Sunbrella® doit être nettoyé régulièrement. Brossez le tissu pour retirer la poussière et lavez-le avec une solution d'eau tiède et de savon doux. Pour les taches tenaces et la moisissure, utilisez une solution composée de 236.6 ml / 1 tasse d'eau de Javel et de 59.2 ml / 0.25 tasse de savon doux pour 3.79L / 1 gal d'eau. Rincez abondamment pour retirer le savon. Laissez sécher à l'air.

**Entretien** : pour préserver l'esthétique des coussins, nous recommandons de ranger le mobilier dans un endroit sec à l'abri des intempéries ou de le couvrir avec une housse pour meubles d'extérieur lorsqu'il n'est pas utilisé.



## COUVERCLE

Les couvre-meubles sont un excellent moyen de protéger votre ensemble de meubles de patio des éléments climatiques et des rayons UV. Par contre, il est important de s'assurer que les couvertures et les meubles sont exempts de moisissures et de débris avant de les couvrir. Il est aussi nécessaire de rapidement découvrir les meubles après la pluie et durant les périodes de grande humidité afin de prévenir l'accumulation de moisissure. Sinon, cela pourrait mener à des dommages permanents des surfaces et des finis.



## COUSSINS

Pour assurer une longue durée de vie à votre ensemble de meubles de jardin, chaque coussin est réalisé en mousse haute densité. Lors de la première utilisation, les coussins peuvent sembler durs, mais au fur et à mesure que vous les utiliserez, ils s'assoupliront pour offrir un confort optimal au fil des saisons.

Les coussins peuvent s'imprégner d'eau s'ils sont excessivement exposés à l'humidité. Pour permettre aux coussins de sécher correctement à l'air, suivez les étapes suivantes :

- Ouvrez la glissière de la housse de coussin pour aérer et faciliter le séchage, sans retirer les housses de coussin.
- Placez les coussins verticalement pour un drainage plus rapide. La fermeture éclair doit être orientée vers le bas.
- Rangez les coussins à l'intérieur pendant les saisons pluvieuses et de mauvais temps.



# Juego de sala tejida con chimenea 5 Piezas

## INSTRUCCIONES DE MANTENIMIENTO

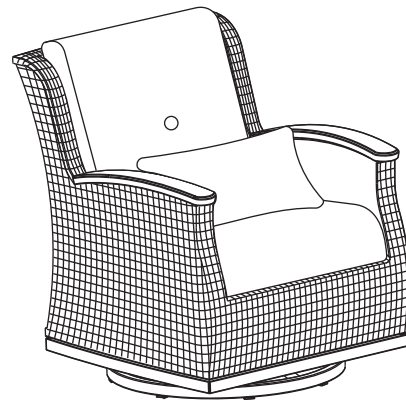
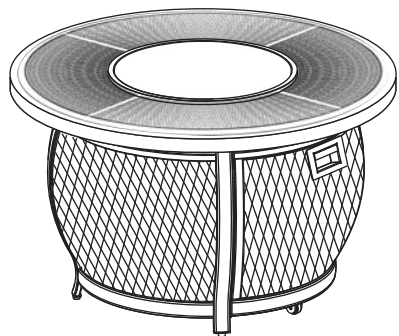

ITM. / ART. 449874

**IMPORTANTE: CONSERVE PARA FUTURA REFERENCIA.  
LEA CUIDADOSAMENTE**

### ¿PARTES DAÑADAS O FALTANTES?

Favor de llamar a nuestro servicio al cliente

**E.U.A. y Canadá :1-888-383-1932**

**o enviar un correo electrónico a [customerservice@agio-usa.com](mailto:customerservice@agio-usa.com).**

9:00 a.m. – 5:00 p.m. (HORA DEL ESTE) LUNES - VIERNES

### Regiones internacionales:

Por favor vista <http://www.agio-usa.com/service-center/costco-international>

/o envíe un correo electrónico a [customerservice@agio-usa.com](mailto:customerservice@agio-usa.com)

Para soporte adicional en video sobre el ensamble, solución de problemas, cuidado y mantenimiento del mueble agio para exteriores, visite nuestra página web

En:[www.agio-usa.com/service-center/maintenance/](http://www.agio-usa.com/service-center/maintenance/)

### Advertencias especiales

ESTE ARTÍCULO PARA EXTERIORES ES SOLAMENTE PARA USO DOMÉSTICO.

NO ES PARA USO COMERCIAL.

**Agio International Corporation**

900 E. Hamilton Avenue,

Suite 100, Campbell,

CA 95008, USA



## ARMAZONES

**Limpieza** - Use un jabón suave y agua tibia. No utilice materiales abrasivos, limpiadores o productos con blanqueador. Enjuague con agua limpia y seque por completo.

**Mantenimiento** - Limpie periódicamente y seque bien. Asegúrese de vaciar el agua acumulada dentro del armazón. Para vaciar los armazones, retire las tapas de las patas e incline los armazones, si es necesario, para sacar toda el agua. Esto es importante. Si se permite que se acumule el agua dentro de los armazones y luego se exponen a temperaturas de congelación, puede ocasionar un daño a la tubería del armazón. Tal daño no lo cubre la garantía. Siempre limpie, vacíe y seque bien antes de almacenar durante el invierno.

Para mejores resultados, siempre guarde o cubra el mueble cuando no lo use.

\*\* cuando limpie o mueva artículos grandes y pesados, siempre deben hacerlo entre dos personas. Nunca arrastre el mueble.



## TELAS (COJINES/ASIENTOS)

La tela Sunbrella® debe limpiarse periódicamente. Quite todo el polvo suelto con un cepillo y lave con una solución de jabón suave y agua tibia. Para manchas más difíciles y moho, lave con una solución de 236.6 ml / 1 taza de blanqueador y 59.2 ml / 0.25 de taza de jabón suave por cada 3.79L / 1 galón de agua. Enjuague bien para eliminar el jabón. Deje que la tela se seque al aire.

**Mantenimiento** - La mejor forma de mantener la belleza de los cojines y de los asientos es guardarlos en un área seca y lejos de la intemperie cuando no se usen o taparlos con fundas para muebles al aire libre disponibles en el mercado.



## CUBIERTA

Las fundas para muebles son una forma estupenda de proteger su conjunto de las inclemencias del tiempo y de la luz UV. Sin embargo, es importante asegurarse de que los muebles y las fundas estén libres de humedad y residuos antes de cubrirlos. Además, es necesario destapar los muebles rápidamente después de la lluvia o durante periodos con mucha humedad para evitar que se acumule. Si no lo hace, puede dañar permanente la superficie y el acabado.

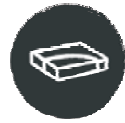

## COJINES

Para garantizar la larga duración de su conjunto para el patio, los cojines de todos los asientos se han fabricado con espuma de alta densidad. Cuando empiece a usar los cojines de los asientos, puede que estén algo duros, pero con el uso continuado se ablandarán y proporcionarán una gran comodidad e n adelante.

Los cojines pueden empaparse si se exponen a abundante agua. Para que se sequen adecuadamente, siga los pasos siguientes:

- Abra la cremallera de la funda del cojin para que ventile y facilitar el proceso de secado. No saque las fundas de los cojines.
- Coloque los cojines en vertical para que se drenen con mayor rapidez. La cremallera debe mirar hacia abajo.
- Guarde los cojines en el interior durante las épocas de lluvias y cuando haga mal tiempo.

\* NOTE: PARTS SHOWN ON PARTS LIST ARE NOT TO SCALE.  
 \* NOTE: LES PIÈCES ILLUSTRÉES NE SONT PAS À L'ÉCHELLE.  
 \* NOTA: LAS PIEZAS MOSTRADAS EN LA LISTA DE PIEZAS NO ESTÁN A ESCALA.

	PARTS LIST LISTE DES PIÈCES LISTA DES PIEZAS	QTY QTÉ CANT	ORDER PART # NUMÉRO DE LA PIÈCE #PIEZA DEL PRODUCTO	DESCRIPTION DESCRIPTION DESCRIPCIÓN
A		1	ZZW03912	FURNITURE COVER HOUSSE DE PROTECTION CUBIERTA DE LOS MUEBLES

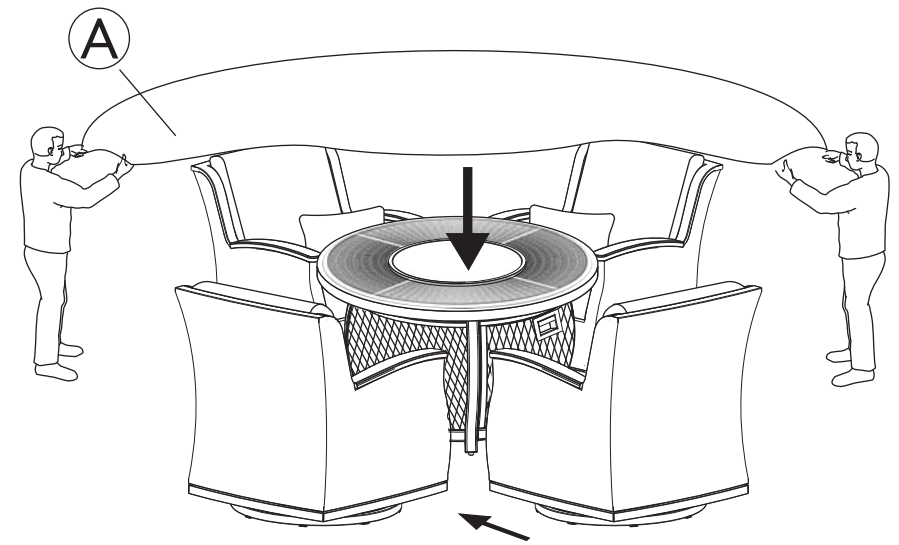

1

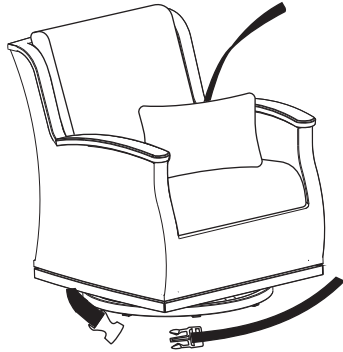

2

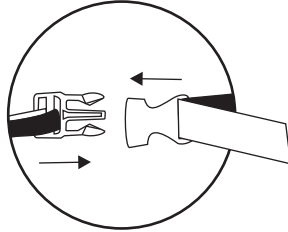

3

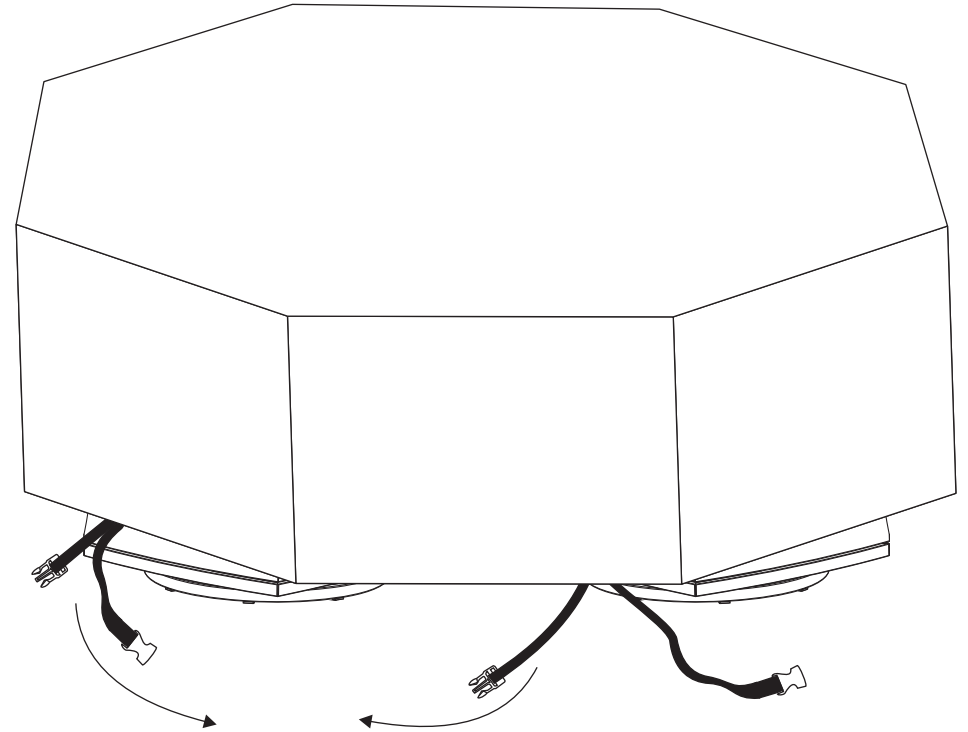
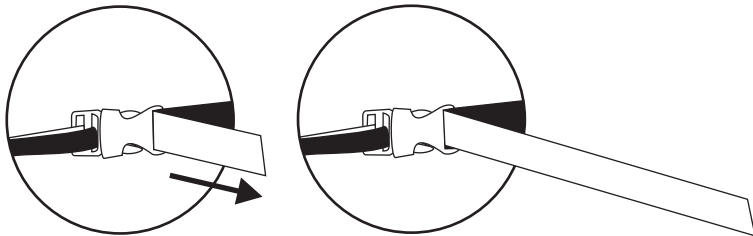

\*The furniture cover (A) is designed to protect your investment from the elements and will repel water. Please note the cover is not 100% waterproof and moisture may seep in if allowed to collect.  
 \*La housse de protection (A) est conçue pour protéger le mobilier et repoussera l'eau. Il faut toutefois noter qu'elle n'est pas entièrement imperméable et que de l'humidité pourrait suinter si on laisse l'eau s'accumuler.  
 \*La cubierta de los muebles (A) está diseñada para proteger su inversión de la intemperie y repelerá el agua. Observe que la cubierta no es 100% a prueba de agua y la humedad se puede filtrar si se deja acumular

# 5 PIECE WOVEN SEATING SET WITH FIRE

ITM. / ART. 449874

**IMPORTANT, RETAIN FOR FUTURE REFERENCE: READ CAREFULLY**

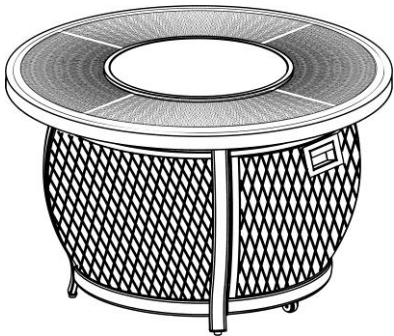

0063-23 0058-23

**Model No.**  
ARM09000

Installer: Leave these instructions with consumer.  
Consumer: Keep these instructions for future reference.

**WARNING:** If the information in this manual is not followed exactly, a fire or explosion may result causing property damage, personal injury or loss of life.

- Do not store or use gasoline or other flammable vapors and liquids in the vicinity of this or any other appliance.
- WHAT TO DO IF YOU SMELL GAS.
- Do not try to light any appliance.
- Do not touch any electrical switch; do not use any phone in your building.
- Immediately call your gas supplier from a neighbor's phone. Follow the gas supplier's instructions.
- If you cannot reach your gas supplier, call the fire department.
- Installation and service must be performed by a qualified installer, service agency or the gas supplier equipment.

**WARNING:** It is UNSAFE to use this product for cooking!



Questions, Problems, Missing Parts? Before returning to your retailer, call our customer service department in the US and Canada at 1-888-383-1932, Monday-Friday, 9 a.m. – 5 p.m Eastern Time. English and French, or you may Email [customerservice@agio-usa.com](mailto:customerservice@agio-usa.com)  
International Regions: Please visit <http://www.agio-usa.com/service-center/costco-international>

**IMPORTANT, RETAIN FOR FUTURE REFERENCE: READ CAREFULLY**

**WARNING:** Before placing the burner cover on, make sure the fire pit has been shut off and the burner has completely cooled down.

Conditions for use of the product: This product is for outdoor use only. Not for commercial use.

**WARNING:** A parasol shall not be placed on it or shall be used with a separate base.

**WARNING:** For Outdoor Use Only

**WARNING:** Do Not Burn Wood or any other materials in this fire pit.

FOR USE WITH 5KG PATIO GAS PROPANE CYLINDER (NOT SUPPLIED) WITH CLIP-ON CONNECTION OR USE WITH NATURAL GAS AFTER CONVERSION KIT (SUPPLIED) IS INSTALLED.

**WARNING:** Improper installation, adjustment alteration, service, or maintenance can cause injury or property damage. Read the installation, operating, and maintenance instructions thoroughly before installing or servicing this equipment. This appliance must be installed and the gas cylinder stored in accordance with the regulations in force.

**WARNING:** USE FACTORY APPROVED REPLACEMENT PARTS AND ACCESSORIES ONLY. USE OF UNAPPROVED PARTS OR ACCESSORIES CAN VOID THE WARRANTY ON THIS PRODUCT AND RESULT IN A HAZARDOUS CONDITION. PLEASE CONTACT US FOR INFORMATION REGARDING REPLACEMENT HOSES, THERMOCOUPLES, ELECTRODES, IGNITION MODULES, LAVA ROCKS, LOGS, ETC.



# TABLE OF CONTENTS

Important Safety Information .....	10
Important Information about Propane.....	11
Specification .....	11
Parts Identification List.....	12-13
Installation .....	13-14
Natural Gas Conversion .....	15-16
Batteries .....	16
Maintenance.....	17
Lighting Instructions .....	17
Burner Cover Assembly.....	17
Troubleshooting Guide.....	18

# IMPORTANT SAFETY INFORMATION

The appliance area must be kept clear and free from combustible materials, gasoline, and other flammable vapors and liquids.

Do not use this appliance if any part has been under water. Immediately call a qualified service technician to inspect the appliance and to replace any part of the control system and any gas control which has been under water.

**Children and adults should be alerted to the hazards of high surface temperatures and kept at a safe distance to avoid burns or clothing ignition.**

**Young children should be carefully supervised when they are anywhere near the appliance.**

**Clothing or other flammable material should not be hung from the appliance, or placed on or near the appliance.**

**Any screen or guard removed for servicing an appliance must be replaced prior to operating the appliance.**

**Installation and repair should be done by a qualified service person. The appliance should be inspected before use and at least annually by a professional service person. More frequent cleaning may be required as necessary. It is imperative that the control compartments, burners and circulating air passageways of the appliance be kept clean.**

Do NOT burn solid fuels in this gas fireplace.

Do NOT ignite the burner before pouring all of the burner media (fire ice) into the burner pan. The media must be evenly distributed over the burner.

During initial firing of fire pit, please stay away from the fire pit for 20 minutes as fire media (fire ice) may pop and hit someone on the face or eyes.

Do NOT ignite or use the fire pit if the burner media (fire ice) are wet. Ensure the burner media are completely dry before igniting as intense heat could cause the media to crack and pop.

It is UNSAFE to use this product for cooking!

**CAUTION:** The propane gas pressure regulator provided with this appliance must be used. This regulator is set for an outlet pressure of 37 mbar.

This outdoor gas appliance is not intended to be installed in or on recreational vehicles and/or boats.

Before each use of this gas appliance, open the LP (Liquid Propane) Tank Drawer and inspect the LP Hose. If there is evidence of excessive abrasion or wear, or the hose is cut, it must be replaced prior to the gas appliance being put into operation. Use only the replacement hose assembly specified in this manual. Inspect the burner before each use of the appliance. The burner must be replaced prior to the appliance being put into operation if it is evident that the burner is damaged. Use only the burner listed in these instructions.

Keep the fuel supply hose away from any heated surfaces. Check the tubing or the flexible hose (at least once per month and each time the cylinder is changed). If it shows signs of cracking, splitting or other deterioration it shall be exchanged for new hose of the same length and of the equivalent quality; The tubing or the flexible hose must be changed within the prescribed intervals Shut off the valve at the gas cylinder or the regulator before moving the appliance Be careful, accessible parts may be very hot. Keep away from young children

Do Not move the appliance during use.

# IMPORTANT SAFETY INFORMATION ABOUT PROPANE (LP) GAS

- The cylinder supply system must be arranged for vapor withdrawal.
- This appliance shall be used only outdoors in a well-ventilated space and shall not be used in a building, garage, or any other enclosed space.
- When this appliance is not in use, the gas must be turned off at the supply cylinder.
- Storage of this appliance indoors is permissible only if the cylinder is disconnected and removed from the appliance.
- Cylinders must be stored outdoors in a well-ventilated area out of the reach of children .Disconnected cylinders must have protective caps installed and must not be stored in a building, garage, or any other enclosed areas.
- Change the gas cylinder in an amply ventilated area, away from any ignition source (candle, cigarettes, other flame producing appliances).
- Check that the regulator seal is correctly fitted and able to fulfill its function.
- Do not obstruct the ventilation holes of the cylinder housing.
- Use only the type of gas and the type of cylinder specified by the manufacturer.
- In case of violent wind particular attention must be taken against tilting of the appliance.

This appliance is for use only with a 5KG Patio Gas Cylinder unless converted for use with Natural Gas with the provided gas conversion kit. The cylinder must be equipped for a clip-on regulator. See Figure 1.

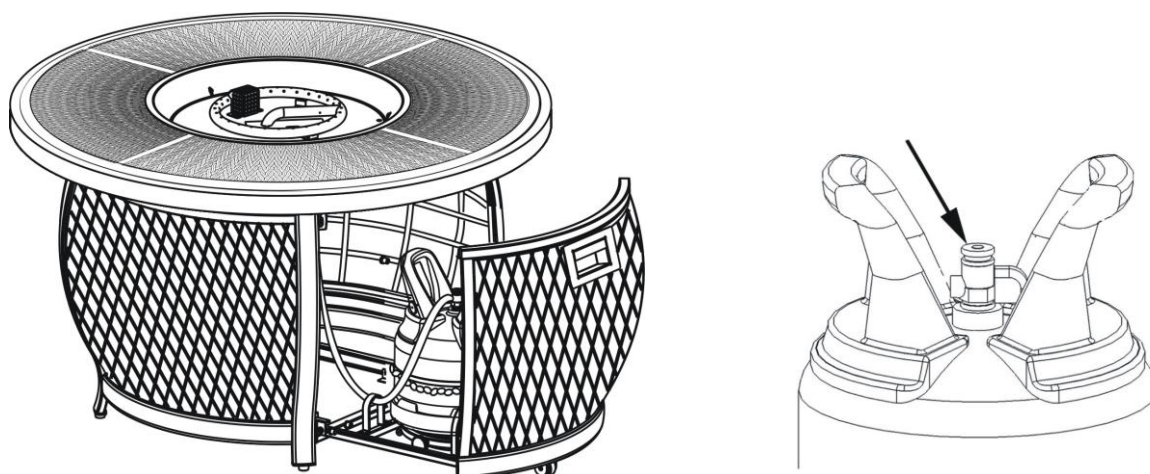

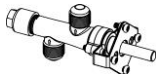









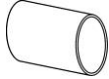















Figure 1

## SPECIFICATIONS

Appliance Category I12H3P	Appliance Type A	Country GB
INPUT	<u>High Fire</u>	<u>Low Fire</u>
Propane(G31)	16 kW 1144 gr per hr.	4.0 kW 286 gr per hr.
Natural Gas (G20)	16 kW	2.5 kW
Propane Regulator Pressure	37 mbar	2.05 mm Injector, Marking: 2.05
Natural Gas Inlet Pressure	20 mbar	3.20 mm Injector, Marking: 3.20
Clearances to combustible surfaces	Sides 24 in / 60.96 cm	Top: 72 in / 182.88 cm

# PARTS IDENTIFICATION LIST

	PART	DESCRIPTION	PART#	QTY
A		CONTROL KNOB	FP2329	1
B		GAS VALVE	FP2330	1
C		THERMOCOUPLE	FP2481	1
D		FLEX CONNECTOR	FP4210	1
E		ELECTRODE	FP4207	1
F		IGNITION MODULE	FP4206	1
G		CHAIN	FP1736	1
H		PROPANE ORIFICE	FP2205	1
I		LP REGULATOR HOSE	FP2025	1
J		FOOT CAPS	FC0759	4
K		"AA" BATTERY	HW0905	1
L		AIR SHUTTER	FP1922	1
M		GLASS BEADS (TOTAL:8KG)	FP2147	2
N		NATURAL GAS ORIFICE	FP2511	1
O		M4 SCREW	HW0898	3
P		1/4" X 20 MM BOLT WITH LARGE WASHER	HW0983	4
Q		HEX BOLT DRIVER	HW0252	1
R		CROSS POINT SCREWDRIVER	HW0900	1
S		BURNER PAN PROTECTIVE RING	FP4285	1
T		FIREPAN/BURNER ASSEMBLY	FP4286	1

U		FIRE PIT BASE	FP4287	1
V		FIRE PIT TABLE TOP	FP4288	1
W		BURNER COVER	FP4289	1
X		ORIFICE HOLDER	FP3573	1
Y		ADDITIONAL TIP-OVER SWITCH	FP1970	1

## INSTALLATION

1. Carefully unpack all items from the box. Place the base in the final position. There must be a minimum of 60.96 cm / 24 inches of clearance from the side of the table top to any combustible walls.

2. Place the fire pit table top onto the fire pit base. Secure the table top to the fire pit base by using the 1/4" x 20 mm screws that are provided. See Figure 2.

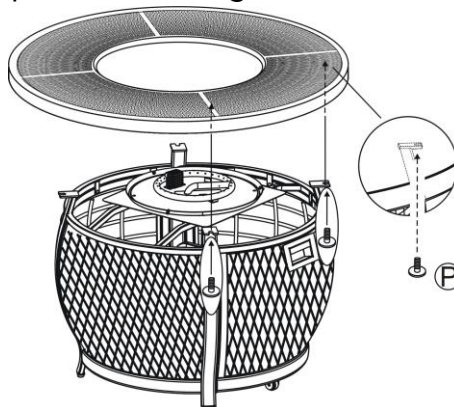

Figure 2

3. Place the burner pan protective ring into the firepan / burner assembly as shown in Figure 3. Align the holes in the burner pan protective ring with the pre-drilled holes on the firepan / burner assembly. Secure the burner pan protective ring to the firepan / burner assembly by using the three M4 screws as shown in Figure 4.

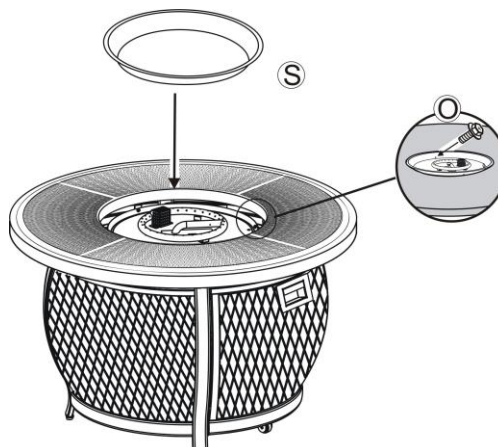

Figure 3

4. Pour ALL of the provided media (fire ice) into the burner pan. The burner MUST be completely covered to ensure the appliance functions properly and safely. Remove any lava rocks or fire ice on top of the ignition well. See Figure 4.

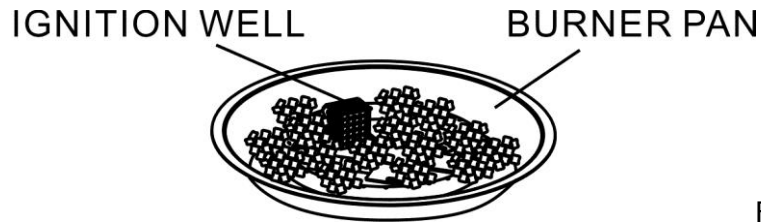

Figure 4

5. Slide the tank drawer out and place the LP tank (not provided) on the rack and secure it with the chain as shown in Figure 5. With the BLACK lever in the “down/off” position as shown in Figure 6, firmly push the regulator onto the tank valve. To open the valve, lift the BLACK lever and turn the handle 90° clockwise to the “ON” position. See Figure 7. Apply a solution of soapy water to the tank-regulator connection and to the valve-hose connection to check for leaks. If soap bubbles continue to form, the connection has a leak. If a leak is found, close the tank valve and tighten all connections. **NEVER USE A FLAME TO CHECK FOR LEAKS.** In case of gas leakage; for instance, in the event of gas leakage, the appliance shall not be used or if alight, the gas supply shall be shut off and the appliance shall be investigated and rectified before it is used again. To remove the regulator, turn the Black Lever counterclockwise and press straight in. See Figure 8.

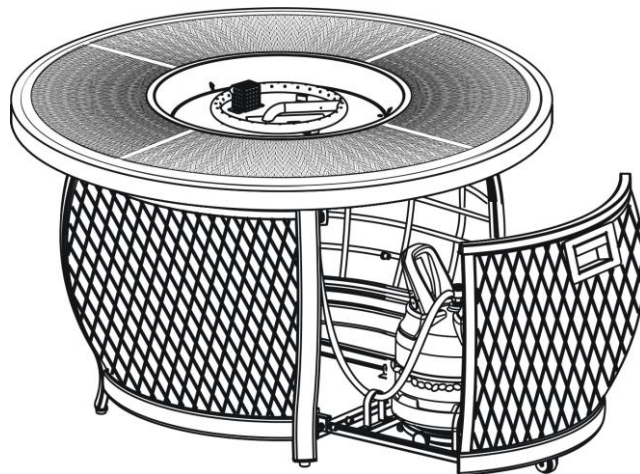

Figure 5

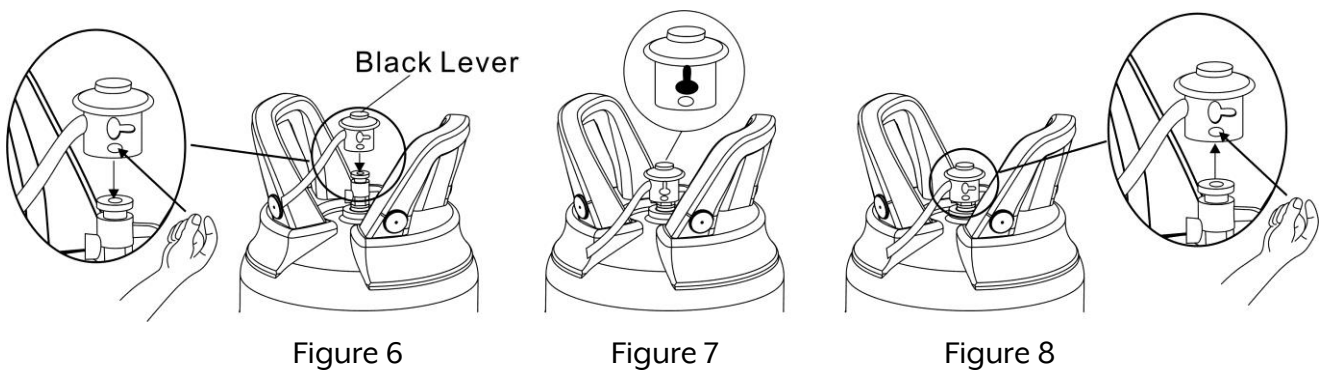

Figure 6

Figure 7

Figure 8



# NATURAL GAS CONVERSION



Natural gas conversion must be performed only by your natural gas provider or service company.

**1. SHUT OFF THE GAS SUPPLY TO THE UNIT AND ANY NEARBY ELECTRICAL SOURCE OR APPLIANCES**

2. Below the burner, carefully disconnect flex connector attached to the orifice holder (see step1).
3. Carefully unscrew the orifice holder from the burner pipe (see step2).
4. Remove the propane orifice from the holder and replace with the natural gas orifice (see step2).
5. Install the air shutter over the burner pipe to cover the air holes. Then reattach the orifice holder to the burner pipe (see step3). Special attention should be paid to the leakage between the holder and natural gas orifice. Do the leakage test with the valve opening.
6. Reattach the flex connector to the orifice holder. (see step 4).

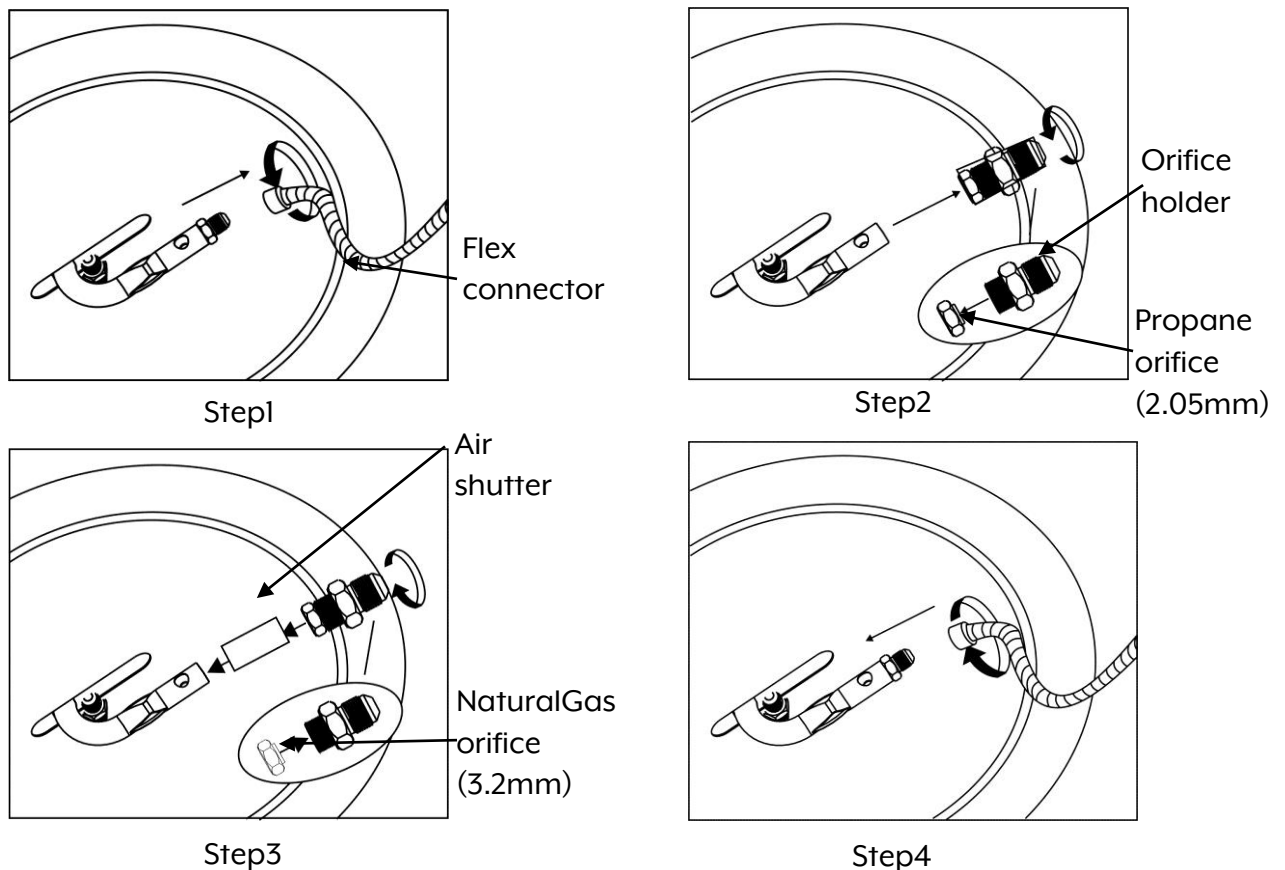

7. To convert the regulator from propane to natural gas, the appliance must be isolated from the gas supply piping system by closing its individual manual shut off valve. Ensure any pressure testing of the gas supply piping system is at test pressure equal to or less than 1/2 psi (3.5KPA)

8. Remove the propane rubber hose from valve and replace with 5/8" natural gas pipe (see step5, natural gas pipe package is not provided).

9. Restore your gas supply and check ALL of the connections for leaks using a solution of soapy water. If a leak is discovered and any bubbles are seen, close the main gas valve and re-tighten ALL of the connections.

**NEVER USE A FLAME TO CHECK FOR GAS LEAKS!**

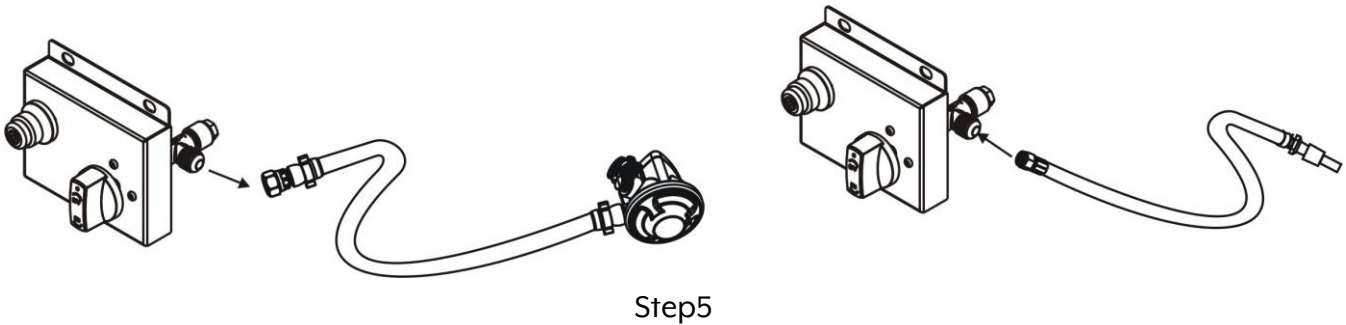

Step5

10. Stick the conversion label on the rating plate as shown in Figure 9.

**Metal Rating Plate**

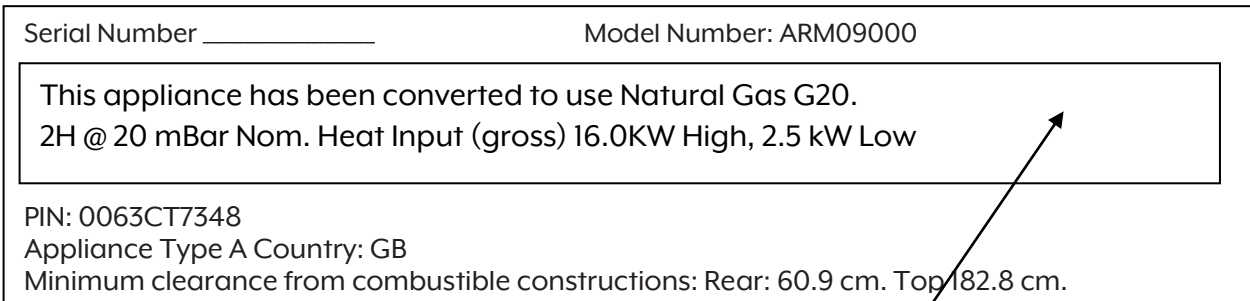

Figure 9

Conversion Label

## BATTERIES

Make sure the control knob is in the "OFF" position. Unscrew the push button cap on the ignition module located on the control panel to access the battery compartment. The ignition module requires one Alkaline AA size battery. The negative (-) end goes in first. See Figure 10. Dispose of the battery safely as it may explode or leak if charged or disposed of in a fire. Make sure of the polarity. Mercury and cadmium free.

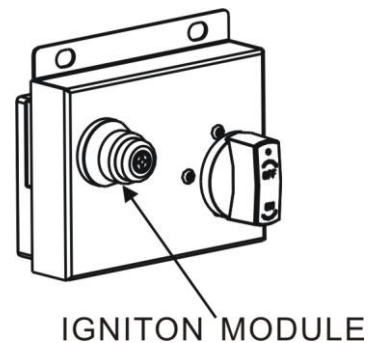

Figure 10

**CAUTIONS: BATTERY INSTRUCTIONS**

- Always purchase the correct size and grade of battery most suitable for the intended use.
- Always replace the whole set of batteries at one time, taking care not to mix old and new ones, or batteries of different types.
- Clean the battery contacts and also those of the device prior to battery installation.
- Ensure the batteries are installed correctly with regard to polarity (+ and -).
- Remove batteries from equipment which is not to be used for an extended period of time.
- Remove used batteries promptly.

For recycling and disposal of batteries to protect the environment, please check the internet or your local phone directory for local recycling centers and / or follow local government regulations.





# MAINTENANCE

The flames should look like those in Figure 11. To clean the burner, use a soft brush after the burner has cooled completely. Never use a vacuum cleaner on the burner. It is recommended to store the fire pit indoors during winter if it will be subjected to freezing temperatures. The LP cylinder must be disconnected and removed from the appliance before the appliance can be stored indoors.

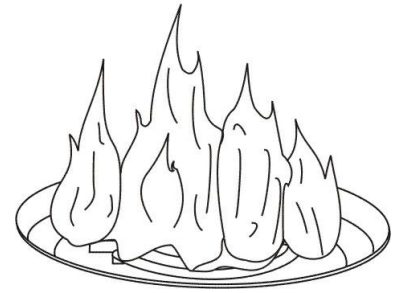
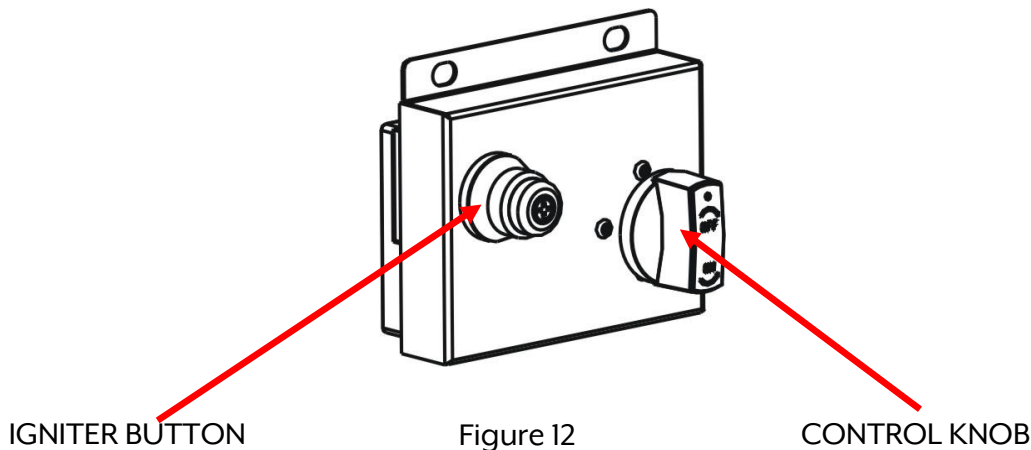

Figure 11

# LIGHTING INSTRUCTIONS

Warning: If these instructions are not followed exactly, a fire or explosion may result causing property damage, personal injury, or loss of life.



1. Read instructions before lighting.
2. Push the control knob in and turn the knob to ON.
3. Hold ignitor to light the burner, release control knob after 15 seconds; if burner does not light, wait 5 minutes, repeat.
4. Adjust flame to desired flame with the control knob. See Figure 12.

# BURNER COVER ASSEMBLY

Place the burner cover on the table top as shown in Figure 13.

**WARNING: BEFORE PLACING THE BURNER COVER ON, MAKE SURE THE FIRE PIT HAS BEEN SHUT OFF AND THE BURNER HAS COMPLETELY COOLED DOWN.**

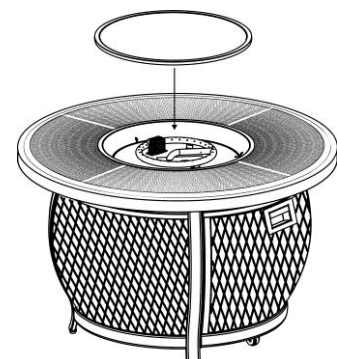
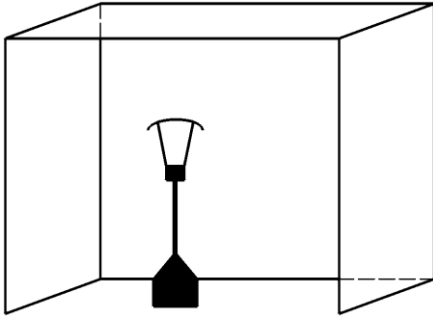

Figure 13

# TROUBLESHOOTING GUIDE

PROBLEM	CAUSE	REMEDY
Burner Won't Light	No propane gas at burner	Check that the gas tank valve is open. Turn the control knob to "ON" and push the control knob in. Make sure tank has propane gas.
	No spark at electrode	Check that the AA battery is installed with the negative (-) end first and has a charge. Check that the wire is connected to the ignition module. Check that the electrode is not cracked or broken.
	Lack of oxygen	Remove excess fire ice from around the ignition well.
Burner won't stay lit after lighting	Thermocouple not in Flame	Check that the tip of the thermocouple is even with the top of the ignition well. Remove any fire ice from the ignition well.
	Thermocouple connection at the main control valve is loose.	Tighten the thermocouple nut at the back of the valve.
	No fire ice on burner	Cover the burner with fire ice per the instructions.

- 1) For use outdoors or in amply ventilated areas.
- 2) An amply ventilated area must have a minimum of 25% of the surface area open.
- 3) The surface area is the sum of the walls surface.



The hose should comply with the standard EN16436;  
The regulator should comply with the standard EN16129;  
Close the gas supply at the valve of the gas cylinder or the regulator after use;  
Do not connect the gas cylinder directly to the appliance without the regulator;  
The recommended cylinder size is-max diameter: 310mm, max height: 400mm.

Manufacturer:

Agio International Corporation  
900 E Hamilton Ave, Suite 100, Campbell, CA 95008, USA

Importer :

Costco Wholesale UK Ltd /  
Costco Online UK Ltd  
Hartspring Lane  
Watford, Herts  
WD25 8JS  
United Kingdom  
01923 213113  
www.costco.co.uk



MADE IN CHINA  
FABRIQUÉ EN CHINE  
HECHO EN CHINA