



MANUFACTURED BY:
Backyard Discovery
3305 Airport Drive, Pittsburg, KS 66762
800-856-4445

Basepoint Business Centre: Rivermead Drive, Westlea, Swindon SN5 7EX Phone: 0800-118-2476
J.P. Coenstraat 7, The Bridge, The Hague, 2595 WP, Netherlands Phone: 0800-567-8990

STERLING POINT

Swing Set

Model # 2300378

The assembly manual must be retained since it contains important information



WARNING

Adult Assembly Required.

Not suitable for children under 36 months due to small parts.

FOR DOMESTIC USE ONLY. INTENDED FOR OUTDOOR USE.



Please visit www.backyarddiscovery.com

For the most up to date assembly manual, to register your set, or to order replacement parts

Para obtener instrucciones en español, visite www.backyarddiscovery.com



**EASY STEP-BY-STEP
3D INTERACTIVE INSTRUCTIONS**

DOWNLOAD THE FREE APP



Made in China

INS-2300378-A-STERLING POINT-ENG 11/14/23

Owner's Manual - Basic Setup Dimensions & Assembly Notes

Place the set on level ground, not less than 6'-7" [2 m] from any structure or obstruction such as a fence, garage, house, overhanging branches, laundry lines, or electrical wires.

- While assembling unit, take time before and after each phase to make sure fort is level. If fort is not level, assembly will be difficult and improper assembly may result. Extra care must be taken to insure the fort is square.
- The safe play area refers to a zone extending 6'-7" (2 m) beyond the play product on all sides, including the space above the play product.

SAFE PLAY AREA DIAGRAM

Ground Dimensions

20'-5 3/4" [6.2 m] x 16'-6 3/4" [5.0 m] x 10'-10" [3.3 m]

Safe Play Area

33'-8" [10.3 m] x 29'-8 3/4" [9.1 m] x 17'-5" [5.3 m]

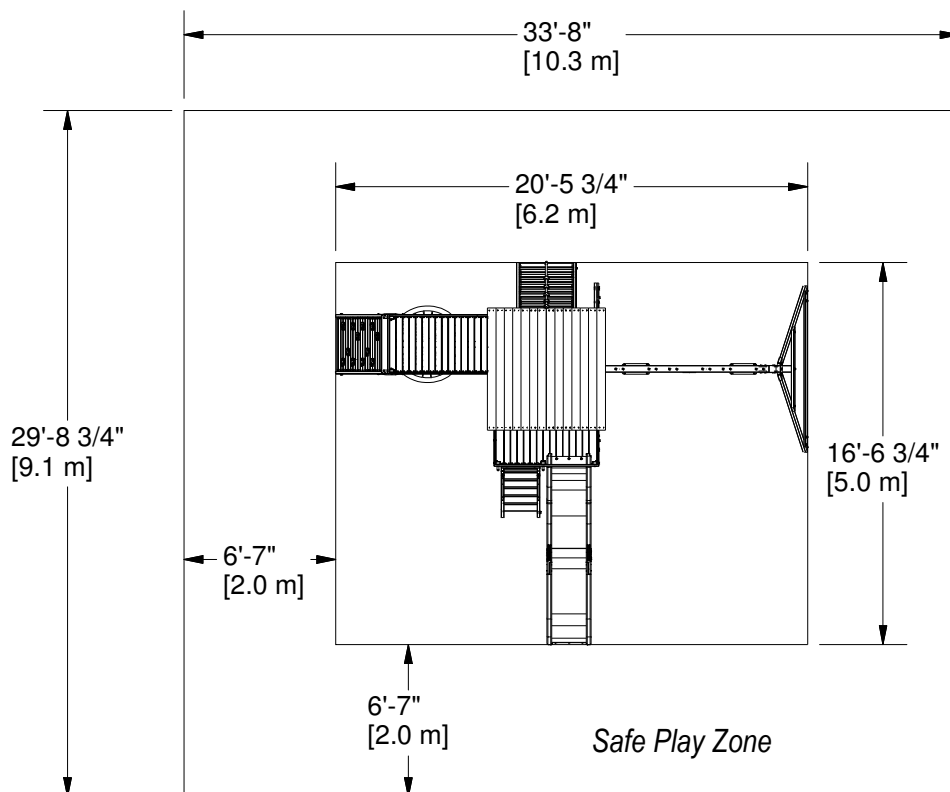

SAFE PLAY HEIGHT: 17'-5" [5.3 m]
 MAXIMUM FALL HEIGHT: 6'-11 1/4" [2.1 m]

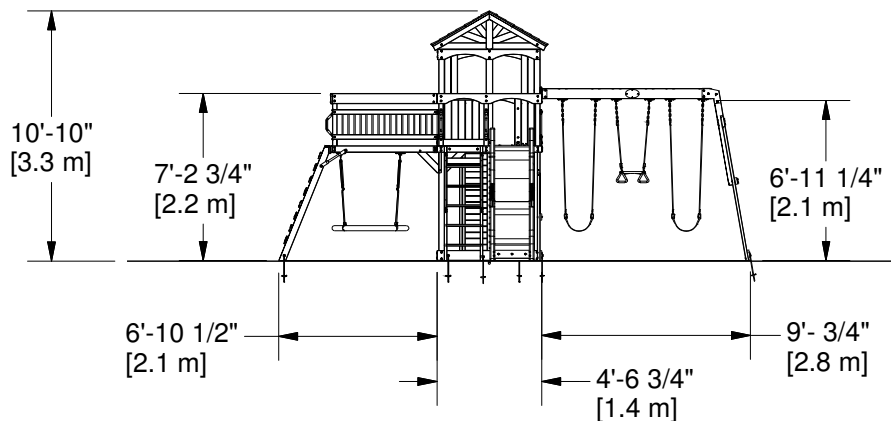

General Information:

Your set has been designed and engineered for children only and for residential use only.
 A maximum of 150 lbs. per child is recommended for play activities designed for individual use.
 A maximum of 120 lbs. per child is recommended for play activities designed for multiple child use.
 A maximum of 9 children is recommended for this swing set.

Owner's Manual - Parts Identification

Wood Components (Not to Scale)



A50 SWING BEAM - W4L16694
(x1) 3 3/8"x5 1/4"x89 1/2" (86x134x2274)

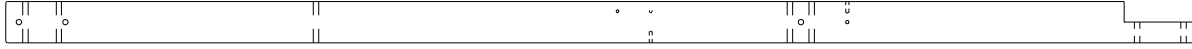

B02 POST - W4L16594
(x1) 3"x3"x86 7/8" (76x76x2206)



B03 POST - W4L16603
(x1) 3"x3"x86 7/8" (76x76x2206)



B04 POST - W4L16604
(x1) 3"x3"x86 7/8" (76x76x2206)



B05 POST - W4L16634
(x1) 3"x3"x31 5/8" (76x76x804)



B06 POST - W4L16635
(x1) 3"x3"x31 5/8" (76x76x804)

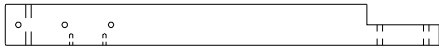

B07 POST - W4L16636
(x1) 3"x3"x31 5/8" (76x76x804)

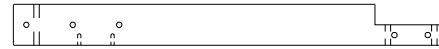

B08 POST - W4L16637
(x1) 3"x3"x31 5/8" (76x76x804)



B09 SWING SUPPORT - W4L16651
(x1) 2 7/8"x3"x54 3/8" (72x76x1381)

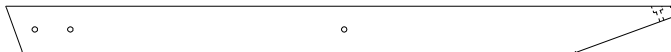

E01 ANGLE BRACE - W4L16596
(x2) 1 3/8"x3 3/8"x48 7/8" (36x86x1241)



E02 DECK BRACE - W4L16598
(x11) 1 3/8"x3 3/8"x17" (36x86x433)



E03 UPRIGHT - W4L16627
(x1) 1 3/8"x3 3/8"x59 5/8" (36x86x1516)

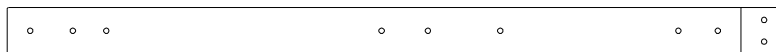

E04 UPRIGHT - W4L16638
(x1) 1 3/8"x3 3/8"x56 7/8" (36x86x1446)



E05 RIGHT RAIL - W4L16666
(x1) 1 3/8"x3 3/8"x64 1/2" (36x86x1640)



E06 LEFT RAIL - W4L16665
(x1) 1 3/8"x3 3/8"x64 1/2" (36x86x1640)

Owner's Manual - Parts Identification

Wood Components (Not to Scale)

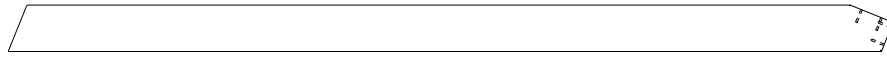

E07 LEFT RAIL - W4L16675
(x1) 1 3/8"x3 3/8"x64 1/2" (36x86x1640)

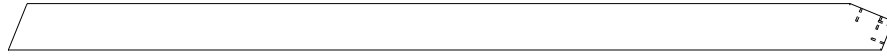

E08 RIGHT RAIL - W4L16676
(x1) 1 3/8"x3 3/8"x64 1/2" (36x86x1640)

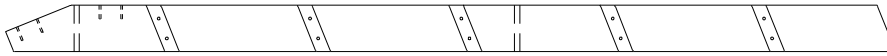

E77 LEFT UPRIGHT - W4L16617
(x1) 1 3/8"x3 3/8"x65" (36x86x1650)



E78 RIGHT UPRIGHT - W4L16618
(x1) 1 3/8"x3 3/8"x65" (36x86x1650)

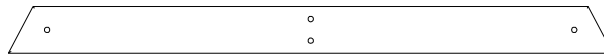

E79 END SUPPORT - W4L16697
(x1) 1 1/2"x3 1/2"x44" (36x86x1120)



E80 ANGLE BRACE - W4L16696
(x2) 1 3/8"x3 3/8"x87 1/8" (36x86x2212)

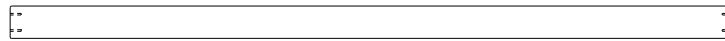

F01 FLOOR JOIST - W4L16610
(x2) 1 3/8"x2 3/8"x52 3/4" (36x60x1340)



F02 UPRIGHT - W4L16611
(x1) 1 3/8"x2 3/8"x30 1/2" (36x60x776)



F03 UPRIGHT - W4L16612
(x1) 1 3/8"x2 3/8"x30 1/2" (36x60x776)



F04 UPRIGHT - W4L16613
(x1) 1 3/8"x2 3/8"x30 1/2" (36x60x776)



F05 UPRIGHT - W4L16630
(x2) 1 3/8"x2 3/8"x30 1/2" (36x60x776)

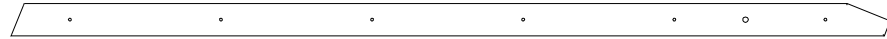

F06 SUPPORT RAIL - W4L16673
(x2) 1 3/8"x2 3/8"x64 1/8" (36x60x1629)



F07 SUPPORT RAIL - W4L16677
(x2) 1 3/8"x2 3/8"x64 1/8" (36x60x1629)



G01 GROUND BOARD - W4L16595
(x1) 1"x5 1/4"x89 1/2" (24x134x2274)



G02 GROUND BOARD - W4L16605
(x2) 1"x5 1/4"x53 3/4" (24x134x1364)

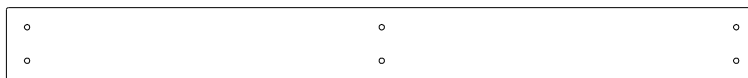

G03 GROUND BOARD - W4L16606
(x1) 1"x5 1/4"x54 3/4" (24x134x1390)

Owner's Manual - Parts Identification

Wood Components (Not to Scale)



G04 WALL RAIL - W4L16602
(x1) 1"x5 1/4"x77" (24x134x1956)

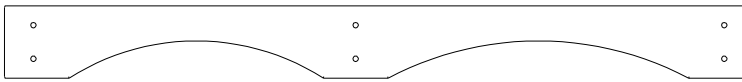

G05 WALL RAIL - W4L16623
(x1) 1"x5 1/4"x54 5/8" (24x134x1388)

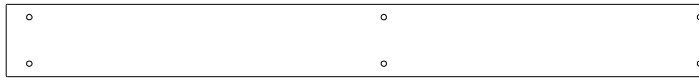

G06 WALL RAIL - W4L16639
(x1) 1"x5 1/4"x51 3/8" (24x134x1304)



G07 WALL RAIL - W4L16659
(x1) 1"x5 1/4"x54 1/2" (24x134x1383)

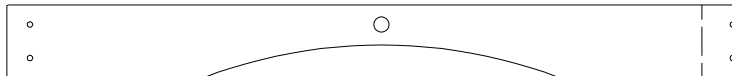

G08 WALL RAIL - W4L16660
(x1) 1"x5 1/4"x53 3/4" (24x134x1364)



G09 WALL RAIL - W4L16661
(x1) 1"x5 1/4"x58 3/8" (24x134x1483)

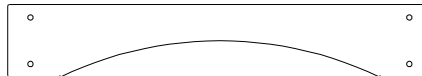

G10 WALL RAIL - W4L16662
(x1) 1"x5 1/4"x31" (24x134x786)

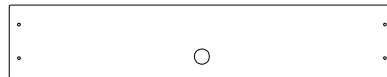

G11 ROPE WALL BOARD - W4L18637
(x1) 1"x5 1/4"x28 1/8" (24x134x714)



G50 GROUND BOARD - W4L16698
(x1) 1"x5 1/4"x86 11/16" (24x134x2202)



H01 FLOOR SUPPORT - W4L16597
(x1) 1"x3 3/8"x77" (24x86x1956)



H02 SAFETY BOARD - W4L16600
(x1) 1"x3 3/8"x74 1/4" (24x86x1887)



H03 FLOOR SUPPORT - W4L16601
(x1) 1"x3 3/8"x77" (24x86x1956)

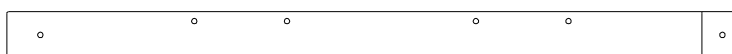

H04 FLOOR RAIL - W4L16607
(x1) 1"x3 3/8"x53 3/4" (24x86x1364)

Owner's Manual - Parts Identification

Wood Components (Not to Scale)



H05 FLOOR RAIL - W4L16608
(x1) 1"x3 3/8"x52 3/4" (24x86x1340)



H06 FLOOR RAIL - W4L16614
(x1) 1"x3 3/8"x54 5/8" (24x86x1388)



H07 FLOOR SUPPORT - W4L16624
(x4) 1"x3"x2 1/8" (24x76x54)



H08 FLOOR RAIL - W4L16628
(x1) 1"x3 3/8"x58 3/8" (24x86x1483)



H09 FLOOR RAIL - W4L16629
(x1) 1"x3 3/8"x54 1/2" (24x86x1383)



H10 FLOOR RAIL - W4L16632
(x1) 1"x3 3/8"x31" (24x86x786)



H11 FLOOR SUPPORT - W4L16648
(x3) 1"x2 3/4"x2 3/8" (24x60x70)



H12 WALL RAIL - W4L16655
(x1) 1"x3 3/8"x54 3/4" (24x86x1390)



H13 WALL RAIL - W4L16664
(x2) 1"x3 3/8"x26 7/8" (24x86x684)



H14 ATTACHMENT BOARD - W4L16667
(x1) 1"x3 3/8"x31" (24x86x786)



H15 ROPE WALL BOARD - W4L16678
(x8) 1"x3 3/8"x28 1/8" (24x86x714)



H17 ATTACHMENT BOARD - W4L16680
(x1) 1"x3 3/8"x31" (24x86x786)



H18 WALL RAIL - W4L16681
(x2) 1"x3 3/8"x54" (24x86x1372)



H19 ROOF RAIL - W4L16682
(x4) 1"x3 3/8"x34 1/2" (24x86x877)



H20 GABLE BOARD - W4L16683
(x2) 1"x3 3/8"x15 5/8" (24x86x397)



H21 GABLE CLEAT - W4L16684
(x2) 1"x3"x3 3/8" (24x76x86)

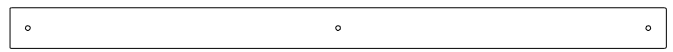

H22 WALL RAIL - W4L16688
(x1) 1"x3 3/8"x54 3/4" (24x86x1390)

Owner's Manual - Parts Identification

Wood Components (Not to Scale)

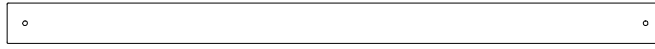

H23 WALL RAIL - W4L16689
(x2) 1"x3 3/8"x54 3/4" (24x86x1390)



H24 WALL BOARD - W4L16690
(x1) 1"x3 3/8"x50 1/8" (24x86x1274)

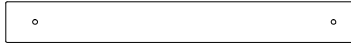

H25 WALL RAIL - W4L16691
(x1) 1"x3 3/8"x29" (24x86x737)

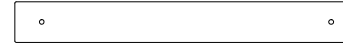

H26 WALL RAIL - W4L16692
(x1) 1"x3 3/8"x28 1/8" (24x86x713)



H27 WALL RAIL - W4L16656
(x1) 1"x3 3/8"x29" (24x86x738)



H28 WALL RAIL - W4L16625
(x1) 1"x3 3/8"x13 1/4" (24x86x336)



H29 WALL RAIL - W4L16699
(x1) 1"x3 3/8"x14 1/8" (24x86x360)



H76 LADDER RUNG - W4L16619
(x5) 1"x3 3/8"x18 1/8" (24x86x460)

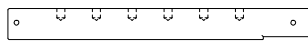

H30 WALL RAIL - W4L19018
(x1) 1"x2 5/8"x25 1/4" (24x66x642)

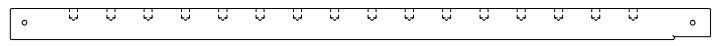

H31 WALL RAIL - W4L19019
(x1) 1"x2 5/8"x58 3/8" (24x66x1483)

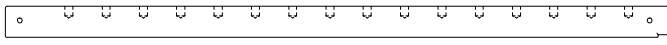

H32 WALL RAIL - W4L19020
(x1) 1"x2 5/8"x55 3/8" (24x66x1407)

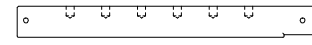

H33 WALL RAIL - W4L19021
(x1) 1"x2 5/8"x25 1/4" (24x66x642)



H77 ATTACHMENT BOARD - W4L16620
(x1) 1"x3 3/8"x20 1/8" (24x86x512)



H80 SLIDE BRACE WIDE - W4L15715
(x1) 1"x3 3/8"x18 3/8" (24x86x466)



H81 SLIDE BRACE UPRIGHT - W4L13301
(x2) 1"x3 3/8"x22 7/8" (24x86x580)

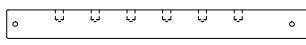

J01 WALL RAIL - W4L16622
(x2) 1"x2 3/8"x25 1/4" (24x60x642)

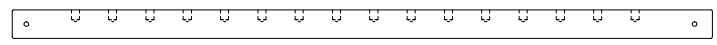

J02 WALL RAIL - W4L16631
(x1) 1"x2 3/8"x58 3/8" (24x60x1483)

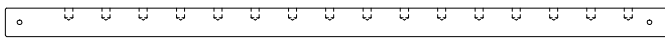

J03 WALL RAIL - W4L16657
(x1) 1"x2 3/8"x55 3/8" (24x60x1407)

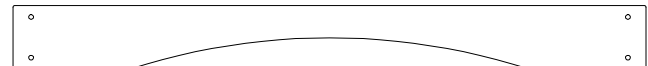

K01 WALL RAIL - W4L16640
(x1) 5/8"x5 1/4"x52 3/4" (16x134x1340)

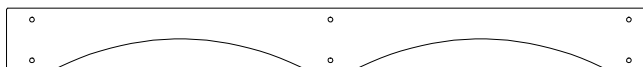

K02 WALL RAIL - W4L16641
(x1) 5/8"x5 1/4"x53 3/8" (16x134x1356)

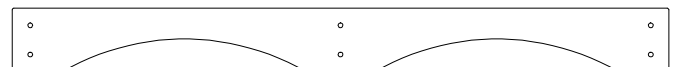

K03 WALL RAIL - W4L16658
(x1) 5/8"x5 1/4"x54 3/4" (16x134x1390)



L01 FLOOR BOARD - W4L16644
(x2) 5/8"x4 1/4"x21 1/4" (16x107x540)



L02 FLOOR BOARD - W4L16645
(x1) 5/8"x4 1/4"x54 5/8" (16x107x1389)

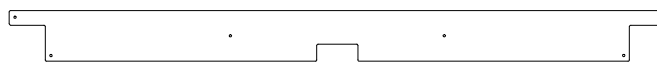

L03 FLOOR BOARD - W4L16646
(x1) 5/8"x4 1/4"x54 5/8" (16x107x1389)

Owner's Manual - Parts Identification

Wood Components (Not to Scale)



M02 FLOOR BOARD - W4L16642
(x11) 5/8"x3 3/8"x21 1/4" (16x86x540)



M03 FLOOR BOARD - W4L16643
(x13) 5/8"x3 3/8"x54 5/8" (16x86x1389)



M04 FLOOR BOARD - W4L19022
(x2) 5/8"x3 3/8"x21 1/4" (16x86x540)



M06 FLOOR BOARD - W4L19023
(x1) 5/8"x3 3/8"x29" (16x86x736)



M05 FLOOR BOARD - W4L16649
(x15) 5/8"x3 3/8"x29" (16x86x736)



M07 WALL BOARD - W4L16652
(x12) 5/8"x3 3/8"x29" (16x86x736)



M08 WALL BOARD - W4L16654
(x7) 5/8"x3 1/4"x26 7/8" (16x82x684)

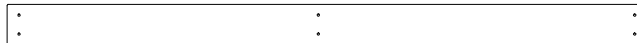

M10 WALL BOARD - W4L16663
(x4) 5/8"x3 3/8"x53 1/4" (16x86x1354)



M11 TOP BOARD - W4L16668
(x2) 5/8"x3 1/4"x31" (16x82x786)



M13 ROCK WALL BOARD - W4L16670
(x4) 5/8"x3 3/8"x28 1/8" (16x86x714)



M12 ROCK WALL BOARD - W4L16671
(x4) 5/8"x3 3/8"x28 1/8" (16x86x714)



M14 ROCK WALL BOARD - W4L16669
(x19) 5/8"x3 3/8"x28 1/8" (16x86x714)



M15 GABLE BOARD - W4L16685
(x4) 5/8"x3 3/8"x18 1/4" (16x86x465)



M16 GABLE BOARD - W4L16687
(x4) 5/8"x3 3/8"x11 3/4" (16x86x300)

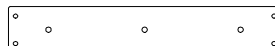

M70 SLIDE BED SUPPORT - W100935
(x1) 5/8"x3 3/8"x19 7/8" (16x86x505)



M73 REAR SUPPORT - W4L16621
(x1) 5/8"x3 3/8"x20 1/8" (16x86x512)



N01 CLEAT - W4L16674
(x2) 5/8"x2 3/8"x57 7/8" (16x60x1470)



N02 ROOF CLEAT - W4L16686
(x4) 5/8"x2 3/8"x26 5/8" (16x60x675)



N06 FILLER BOARD - W4L16672
(x1) 5/8"x2 1/8"x28 1/8" (16x54x714)



SP71 SWING BEAM SUPPORT - W4L16695
(x1) 3 3/8"x3 3/8"x49 1/2" (86x86x1256)

Owner's Manual - Parts Identification

Wood Components (Not to Scale)



T01 SUPPORT BOARD - W4L16599
(x2) 1"x1 3/8"x46 5/8" (24x34x1184)



T02 SUPPORT BOARD - W4L16609
(x1) 1"x1 3/8"x52 5/8" (24x34x1336)



T03 SUPPORT BOARD - W4L16615
(x1) 1"x1 3/8"x24 3/8" (24x34x619)



T04 SUPPORT BOARD - W4L16616
(x1) 1"x1 3/8"x21" (24x34x533)

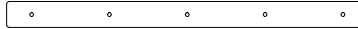

T05 SUPPORT BOARD - W4L16626
(x2) 1"x1 3/8"x18 7/8" (24x34x478)

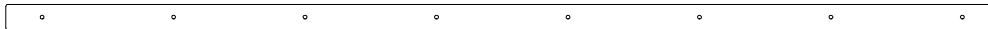

T06 SUPPORT BOARD - W4L19024
(x2) 1"x1 3/8"x51 3/4" (24x34x1314)



Y01 WALL BOARD - W4L16693
(x6) 5/8"x3 5/8"x26 7/8" (16x91x684)



Y02 WALL BOARD - W4L16653
(x2) 5/8"x3 7/8"x29" (16x99x736)



B01 POST - W2A03427
(x1) 3"x3"x86 7/8" (76x76x2206)

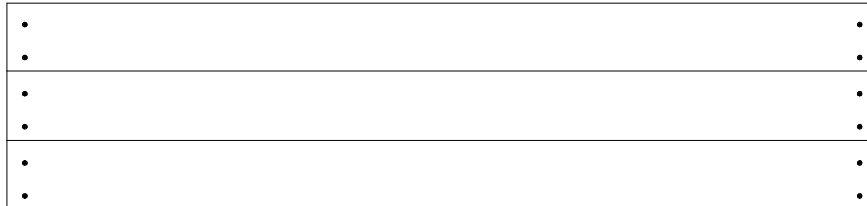

RP1 PEAK ROOF PANEL - W2A03428
(x2) 1 5/8"x15"x59 1/8" (42x382x1613)

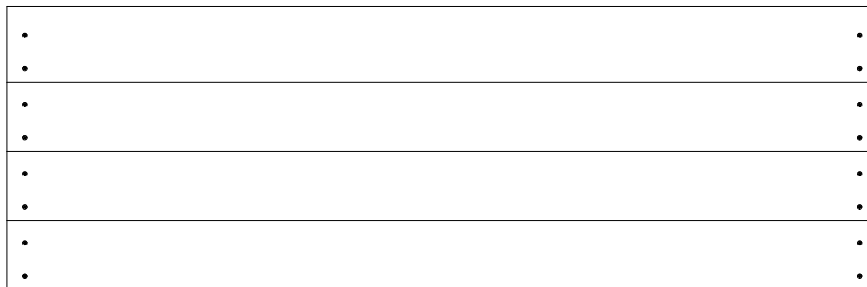

RP2 ROOF PANEL - W2A03429
(x2) 1 5/8"x20 5/8"x66" (42x524x1613)

Owner's Manual - Parts Identification

Hardware Components

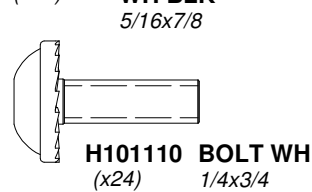
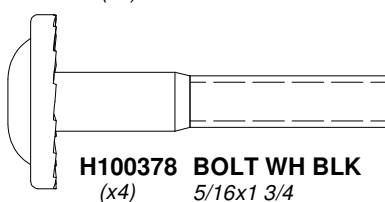
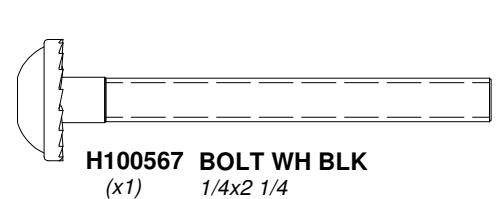
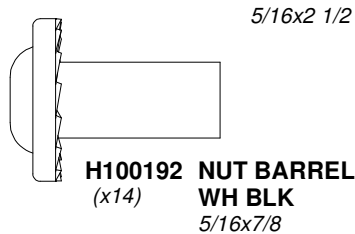
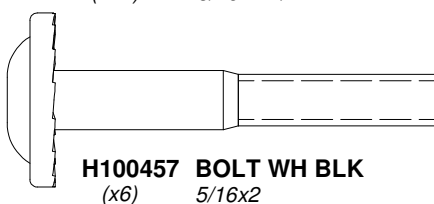
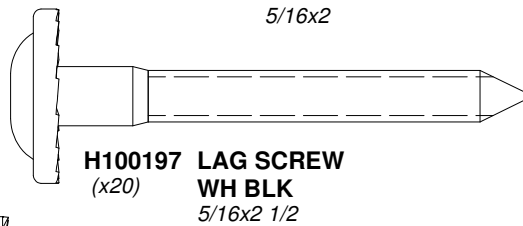
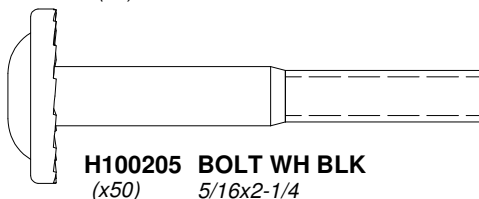
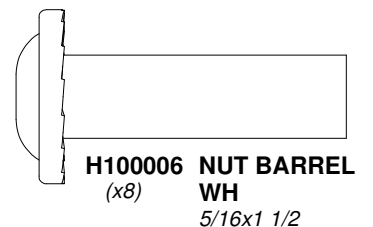
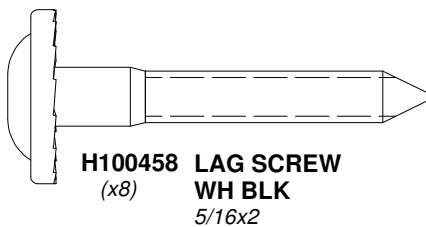
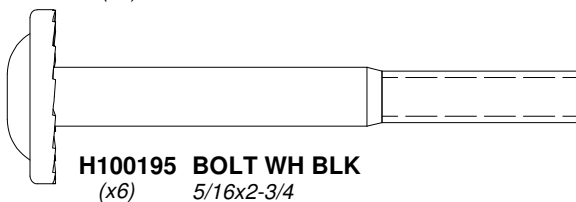
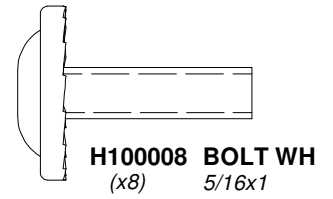
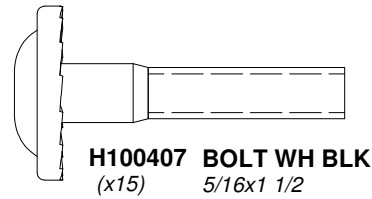
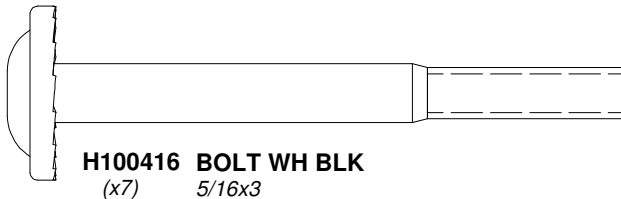
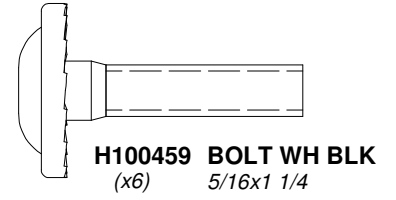
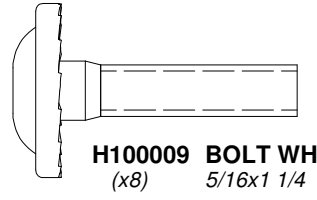
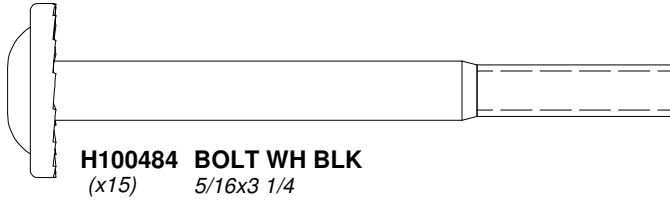
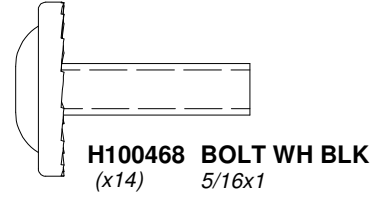
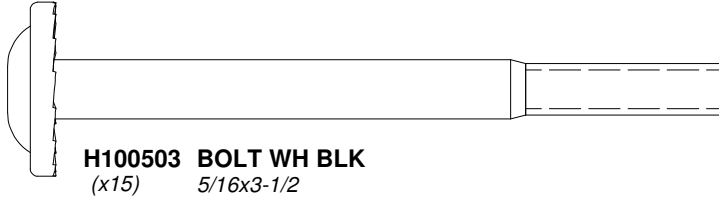
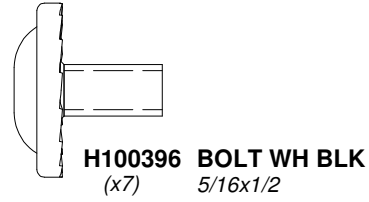
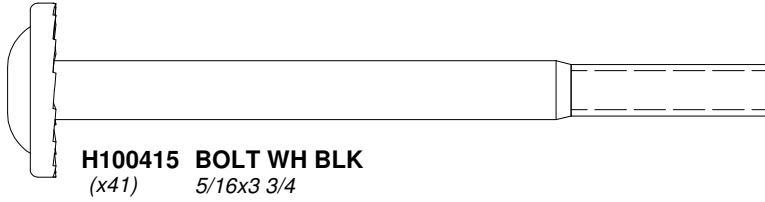
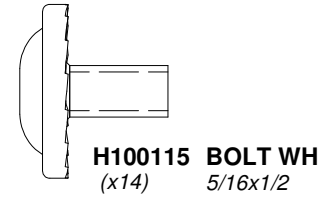
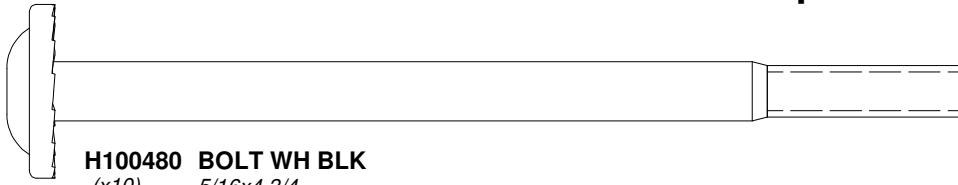

Owner's Manual - Parts Identification

Hardware Components



H100654 BOLT HEX
(x12) 3/8x5-1/2

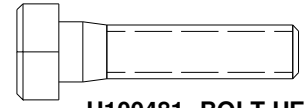

H100481 BOLT HEX BLK
(x4) 5/16x1 1/4

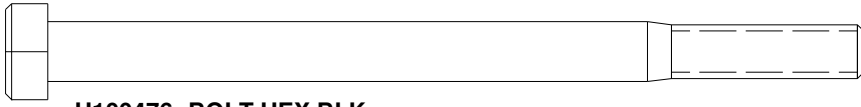

H100476 BOLT HEX BLK
(x2) 5/16x4 1/4

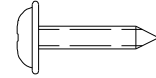

H100128 SCREW PWH
(x4) 8x5/8

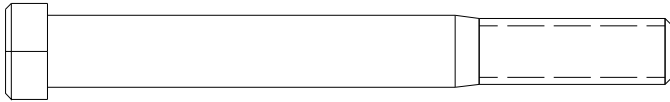

H100434 BOLT HEX
(x4) 3/8x3 1/4

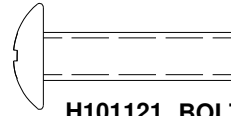

H101121 BOLT PTH BLK with LOCTITE
(x4) 1/4x1

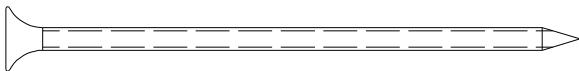

H100092 SCREW PFH
(x8) 8x3



H100831 NUT BARREL PTH BLK
(x4) 1/4x3/4

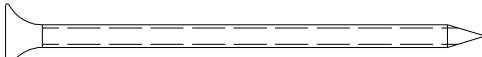

H100090 SCREW PFH
(x70) 8x2 1/2"

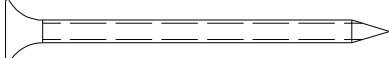

H100111 SCREW PFH
(x128) 8x2

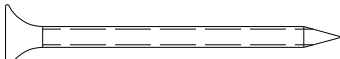

H100089 SCREW PFH
(x75) 8x1 3/4

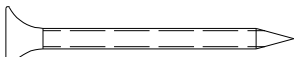

H100086 SCREW PFH
(x296) 8x1 1/2



H100087 SCREW PFH
(x184) 8x1 1/4

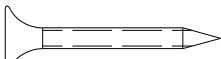

H100088 SCREW PFH
(x34) 8x1 1/8

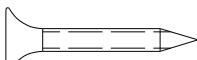

H100385 SCREW PFH BLK
(x24) 8x1

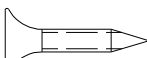

H100121 SCREW PFH
(x6) 8x3/4



H100479 NUT LOCK BLK
(x2) 5/16

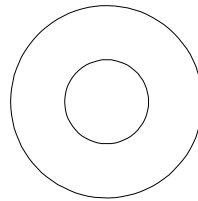

H100102 WASHER FLAT
(x16) 11x25

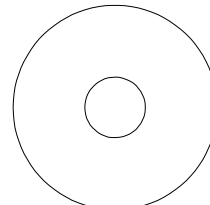

H100478 WASHER FLAT BLK
(x8) 8x27

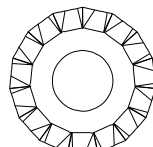

H100198 WASHER LOCK EXT BLK
(x159) 8x19

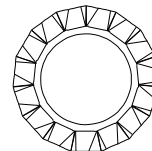

H100199 WASHER LOCK EXT BLK
(x7) 12x19

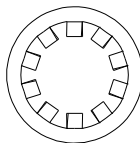

H100107 WASHER LOCK INT
(x16) 10x18

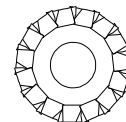

H100405 WASHER LOCK EXT BLK
(x13) 6x15

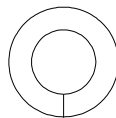

H100477 WASHER SPLIT BLK
(x4) 5/16

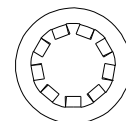

H100108 WASHER LOCK INT
(x24) 8x15

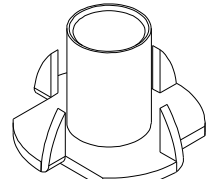

H100073 T-NUT
(x16) 3/8

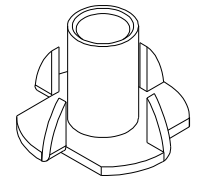

H100074 T-NUT
(x14) 5/16

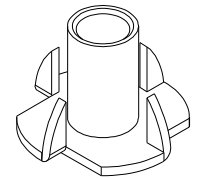

H100379 T-NUT BLK
(x186) 5/16

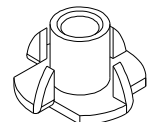

H100398 T-NUT BLK
(x1) 1/4

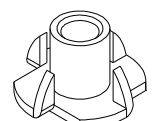

H100072 T-NUT
(x24) 1/4

Owner's Manual - Parts Identification

Hardware Components

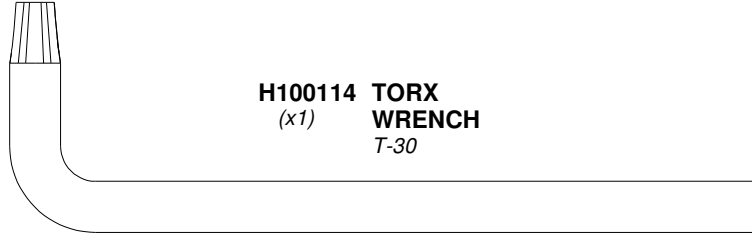

**H100114 TORX
(x1) WRENCH
T-30**

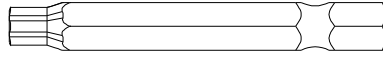

**H100147 TORX BIT
(x1) T-30**

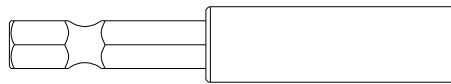

**H101100 MAGNETIC
(x1) DRIVER**

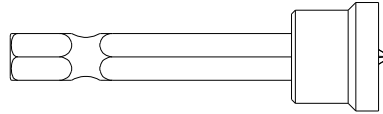

**H100764 SCREW
(x1) SETTER**

Owner's Manual - Parts Identification

Accessory Components (Not to Scale)



A6P00520
(x1) ROPE

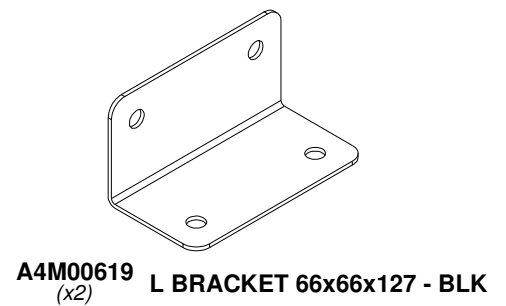
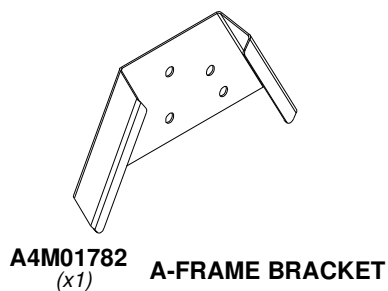
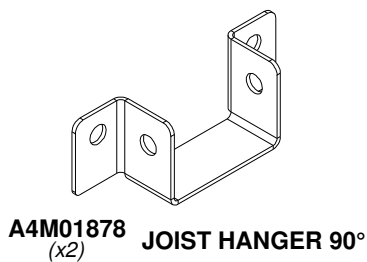
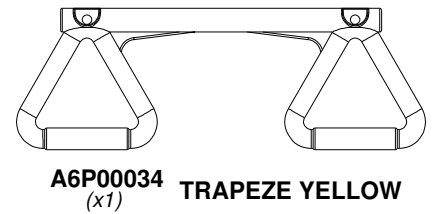
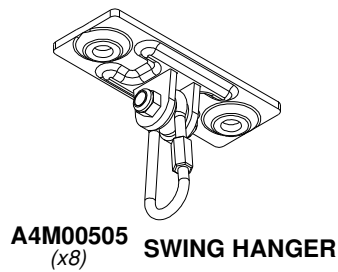
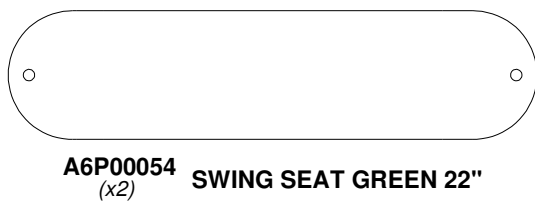
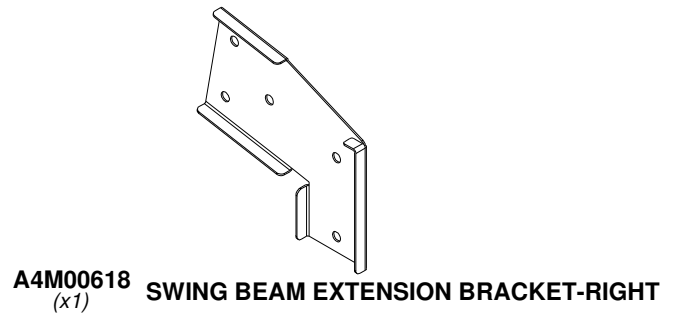
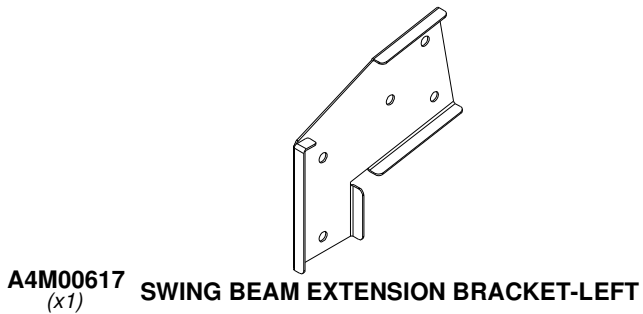
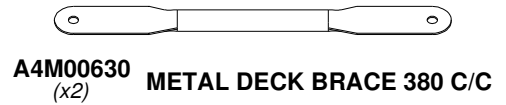
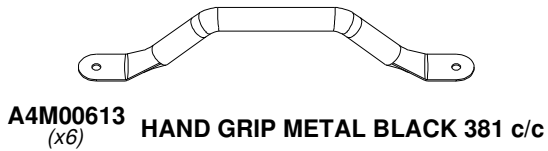

Owner's Manual - Parts Identification

Accessory Components (Not to Scale)

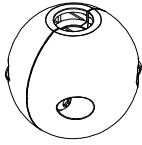

A6P00508
(x7) **ROPE CLAMP KIT**

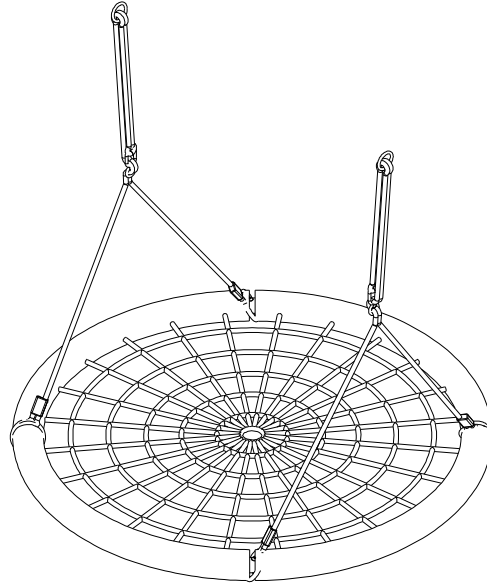

A4M01495
(x1) **40" WEB SWING**

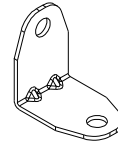

A4M01047
(x7) **L BRACKET 2.5x38x55x55**



A100178
(x10) **AUGER GROUND STAKE**

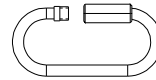

A100069
(x6) **QUICK LINK**

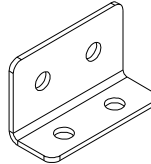

A4M00855
(x1) **L BRACKET 51x32x82x3.175**

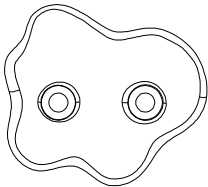

A6P00036
(x6) **GREEN HC ROCK #1**

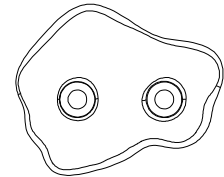

A6P00037
(x6) **GREEN HC ROCK #2**



A4M00597
(x44) **METAL TUBE**



A100164
(x1) **BYD ID TAG (LARGE) AGES 3-10**

Owner's Manual - Parts Identification

Accessory Components (Not to Scale)

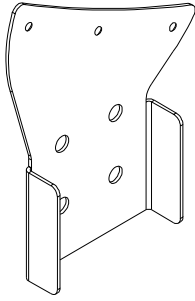

A4M01091 60" SLIDE BRACE (RIGHT)
(x1)

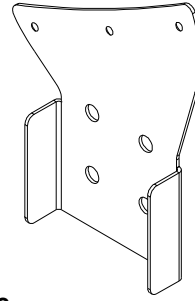

A4M01092 60" SLIDE BRACE (LEFT)
(x1)

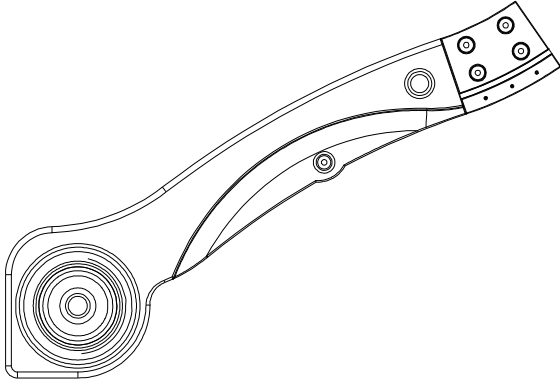

A6P00484 SLIDE RAIL 10' BOTTOM RIGHT GREEN
(x1)

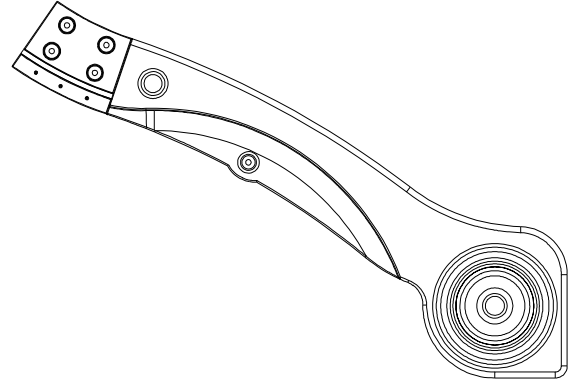

A6P00483 SLIDE RAIL 10' BOTTOM LEFT GREEN
(x1)

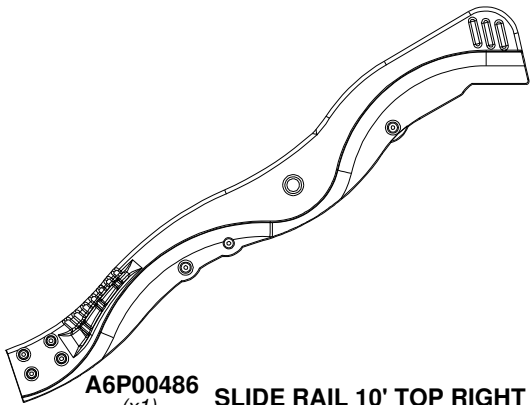

A6P00486 SLIDE RAIL 10' TOP RIGHT GREEN
(x1)

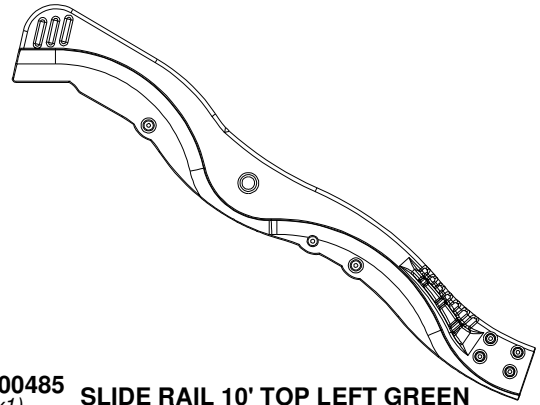

A6P00485 SLIDE RAIL 10' TOP LEFT GREEN
(x1)



A6P00487 SLIDE TUBE SUPPORT
(x4)

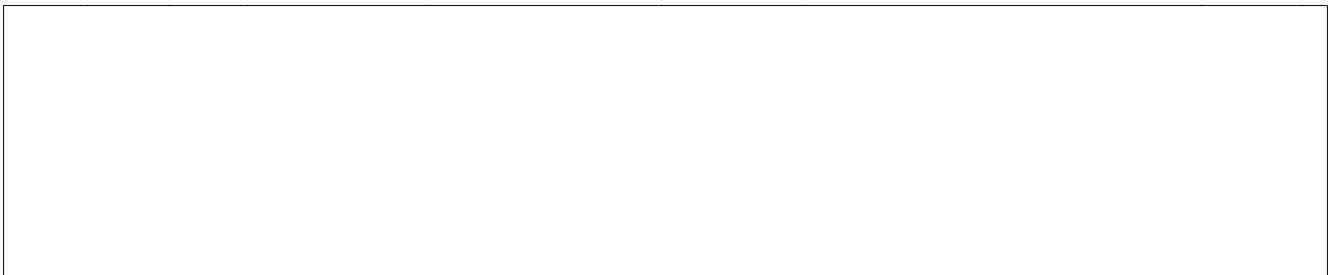

A6P00385 SLIDE BED 10' DARK GREEN
(x1)

PRE-ASSEMBLY STEP 1 - SORTING PARTS

It is critical for ease of assembly that you take the time to sort and organize the wood and hardware.

WOOD PARTS:

- Organize wood parts by the three-digit, alpha-numeric number stamped on each board (ex. P01).
- If there are multiple boards with the same stamped number, stack those pieces together.
- Stamps can be found on the flat surface of the boards or on the end of the boards.
- Allow yourself plenty of room - the wood pieces can take up a significant amount of space.

NOTE: CARTONS ARE NOT ORGANIZED BY BOARD NUMBER.

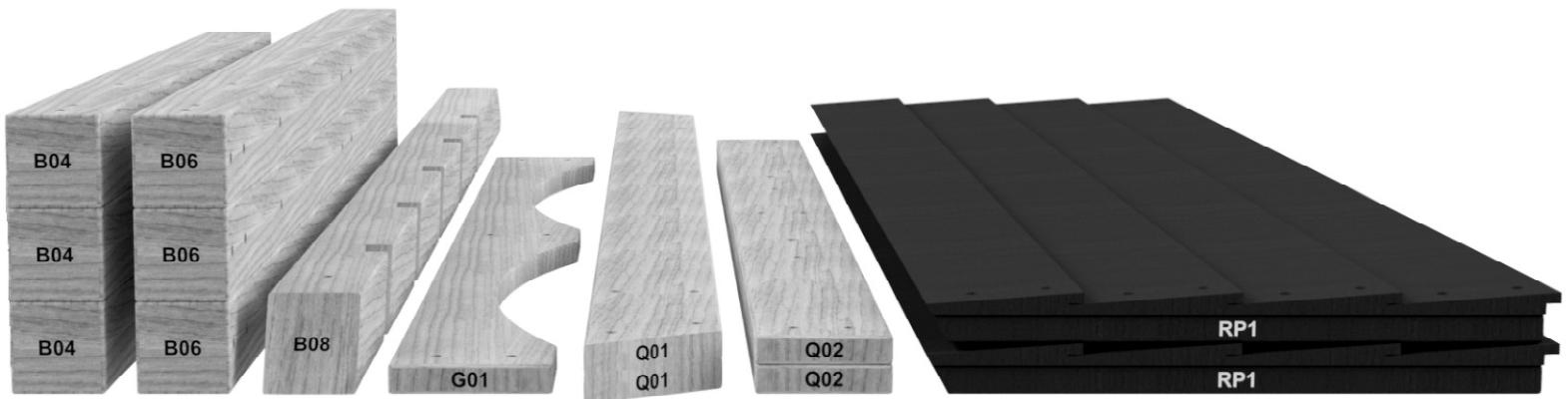

HARDWARE PARTS:

- We recommend that you have a separate table to organize the hardware.
- Hardware bags are printed with a seven-digit, alpha-numeric part number.
- You can organize your hardware by part number or group by hardware type (i.e. bolts, nuts, etc.).
- During assembly you only need to reference the last four digits of the number.

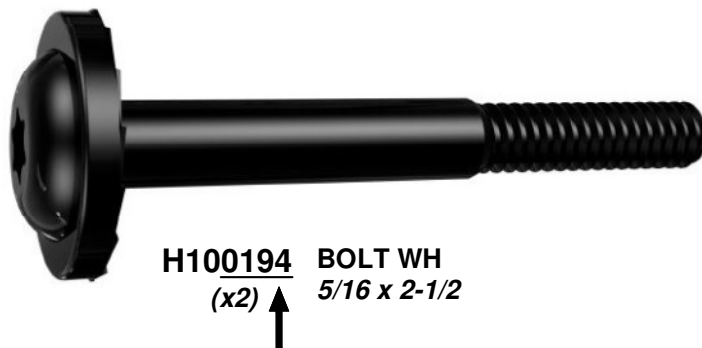

PRE-ASSEMBLY STEP 2 - TOOLS REQUIRED



**Cordless Drill or
Electric Drill**



**Drill Attachments:
Phillips Head**



**1/8", 3/16", 3/8" & 7/16"
Drill Bits**



Phillips Screw Driver



Open End Wrenches 1/2" & 9/16"



**3/8" Drive Ratchet, 1/2" &
9/16" STD Sockets 1/2" & 9/16" Deep
Sockets**



Claw Hammer



Rubber Mallet - Optional



Tape Measure

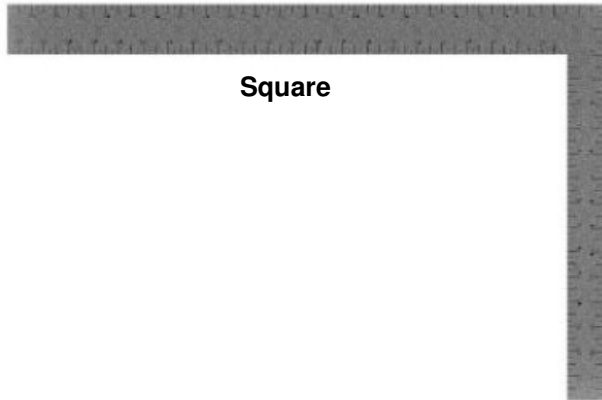

Square





Level 24"

PRE-ASSEMBLY STEP 3 - CHOOSE YOUR ASSEMBLY METHOD



There are several types of assembly instructions available to you.

1. Printed Assembly Manual included with your set
2. BILT APP - 3D interactive instructions
3. Combination of the Printed Manual and BILT APP (Note: Step numbers can differ between the two methods)

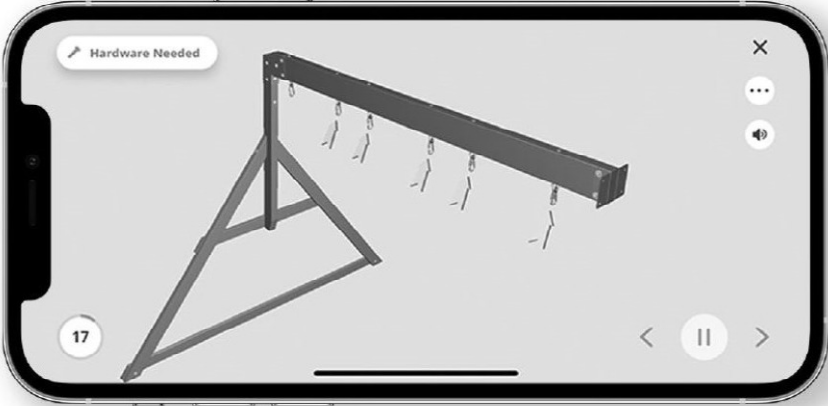

Scan for easy 3D instructions

Download the BILT app
before you begin



The image shows a smartphone screen displaying the BILT app interface. The screen features a 3D assembly diagram of a metal structure. At the top left, there is a button labeled "Hardware Needed". At the bottom left, the number "17" is displayed in a circle. At the bottom right, there are navigation icons: a back arrow, a pause button, and a forward arrow. The app interface is clean and modern, with a white background and grey accents.

STEP 1 - ROCK WALL

QTY	PART NUMBER	DESCRIPTION
24	H100072	T-NUT 1/4
24	H100108	WASHER LOCK INT 8x15
24	H101110	BOLT WH 1/4x3/4



M13 ROCK WALL BOARD - W4L16670
(x4) 5/8"x3 3/8"x28 1/8" (16x86x714)



M12 ROCK WALL BOARD - W4L16671
(x4) 5/8"x3 3/8"x28 1/8" (16x86x714)

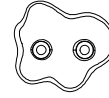

A6P00036 GREEN HC ROCK #1
(x6)

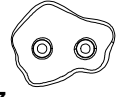

A6P00037 GREEN HC ROCK #2
(x6)

TIP:
INSTALL T-NUTS IN WOOD FIRST

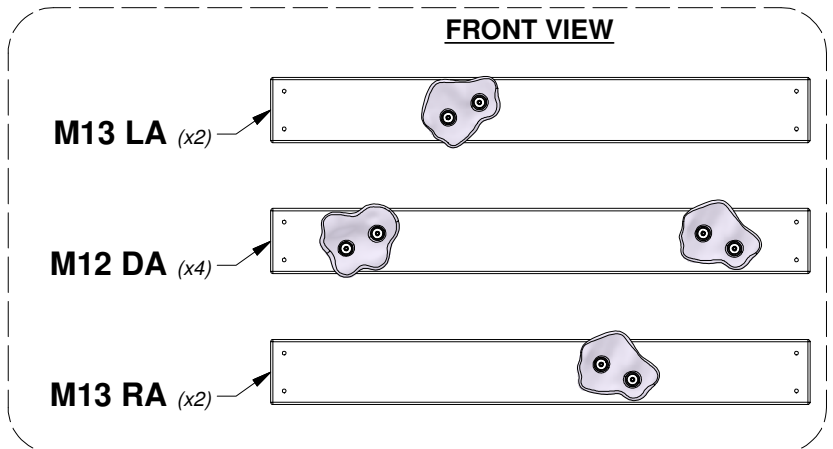
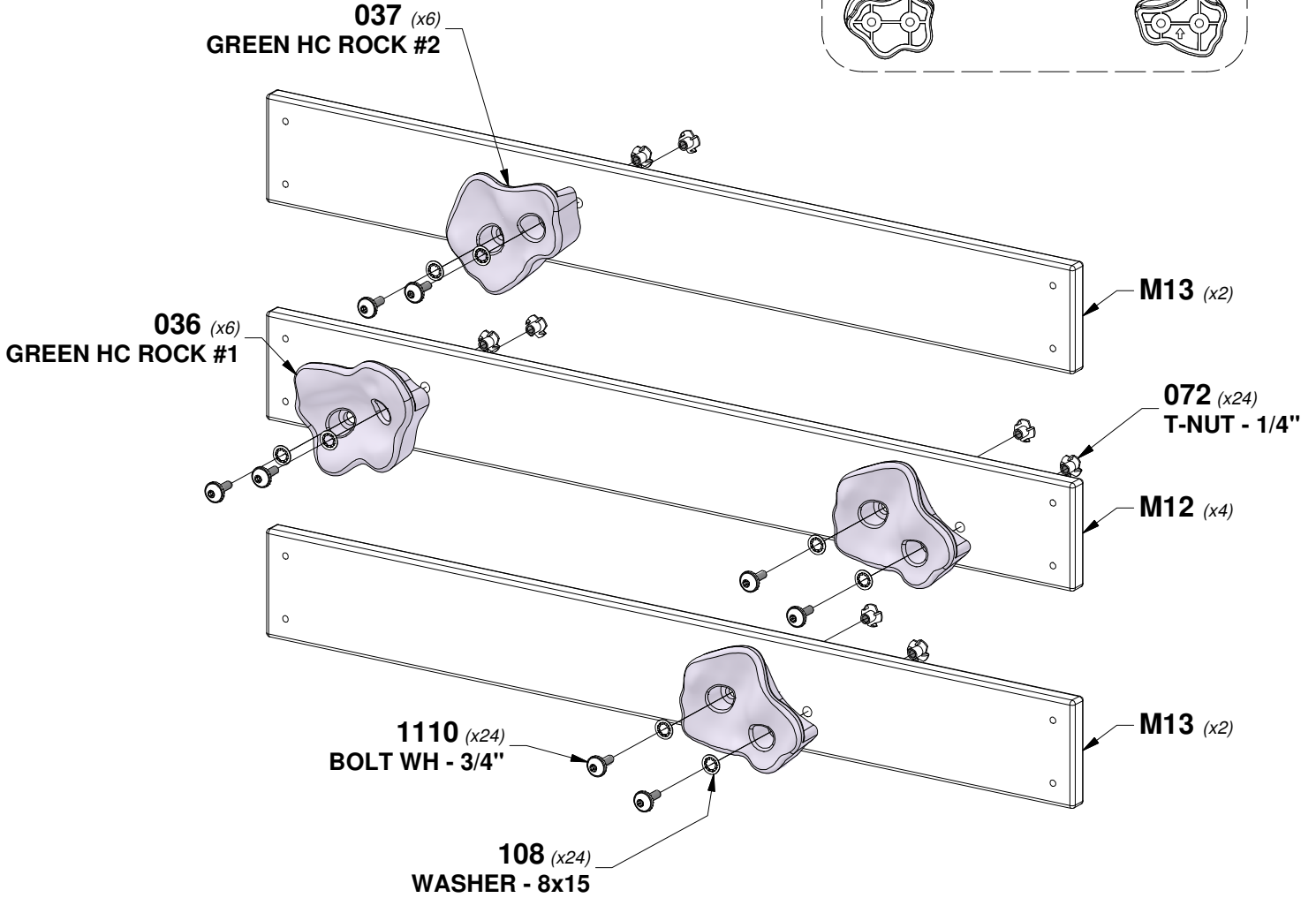
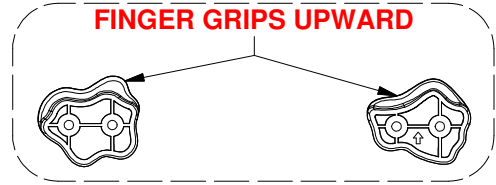

STEP 2 - ROCK WALL

QTY	PART NUMBER	DESCRIPTION
74	H100086	SCREW PFH 8x1-1/2"

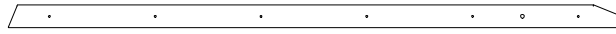
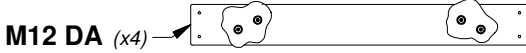
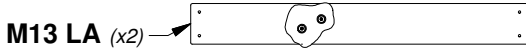

F06 SUPPORT RAIL - W4L16673
(x2) 1 3/8"x2 3/8"x64 1/8" (36x60x1629)



M14 ROCK WALL BOARD - W4L16669
(x10) 5/8"x3 3/8"x28 1/8" (16x86x714)

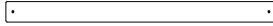

N06 FILLER BOARD - W4L16672
(x1) 5/8"x2 1/8"x28 1/8" (16x54x714)

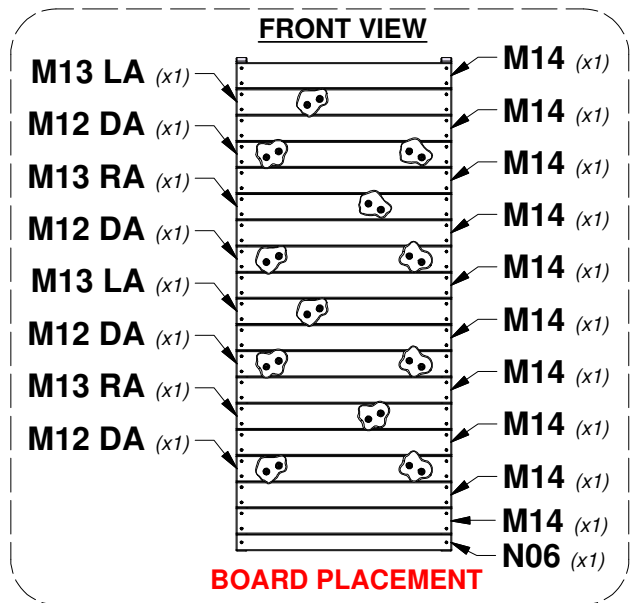
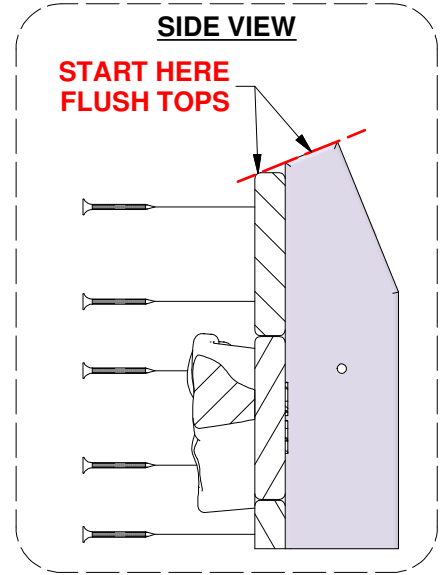
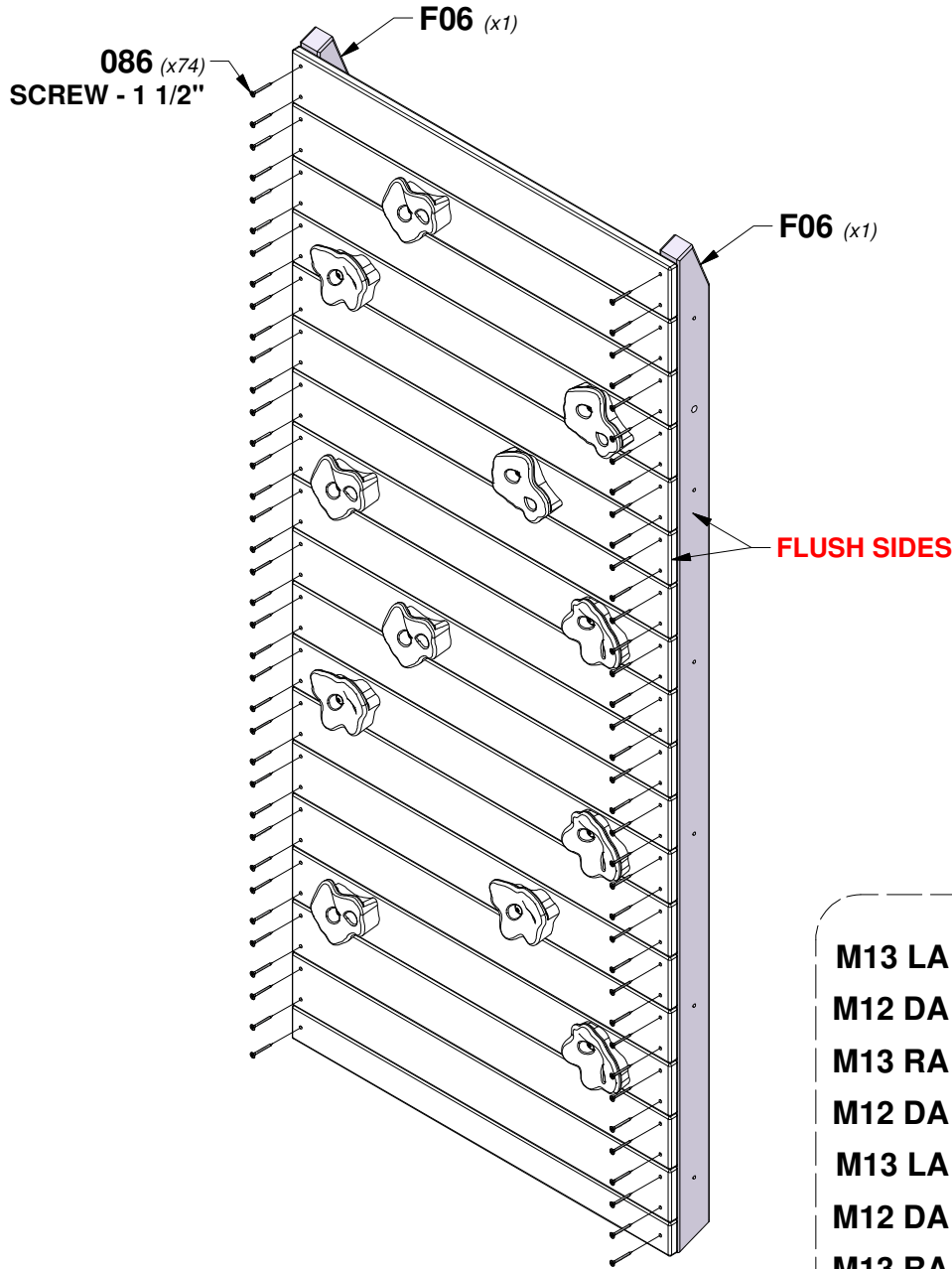

STEP 3 - ROCK WALL

QTY	PART NUMBER	DESCRIPTION
12	H100090	SCREW PFH 8x2 1/2



E06 LEFT RAIL - W4L16665
 (x1) 1 3/8"x3 3/8"x64 1/2" (36x86x1640)



E05 RIGHT RAIL - W4L16666
 (x1) 1 3/8"x3 3/8"x64 1/2" (36x86x1640)

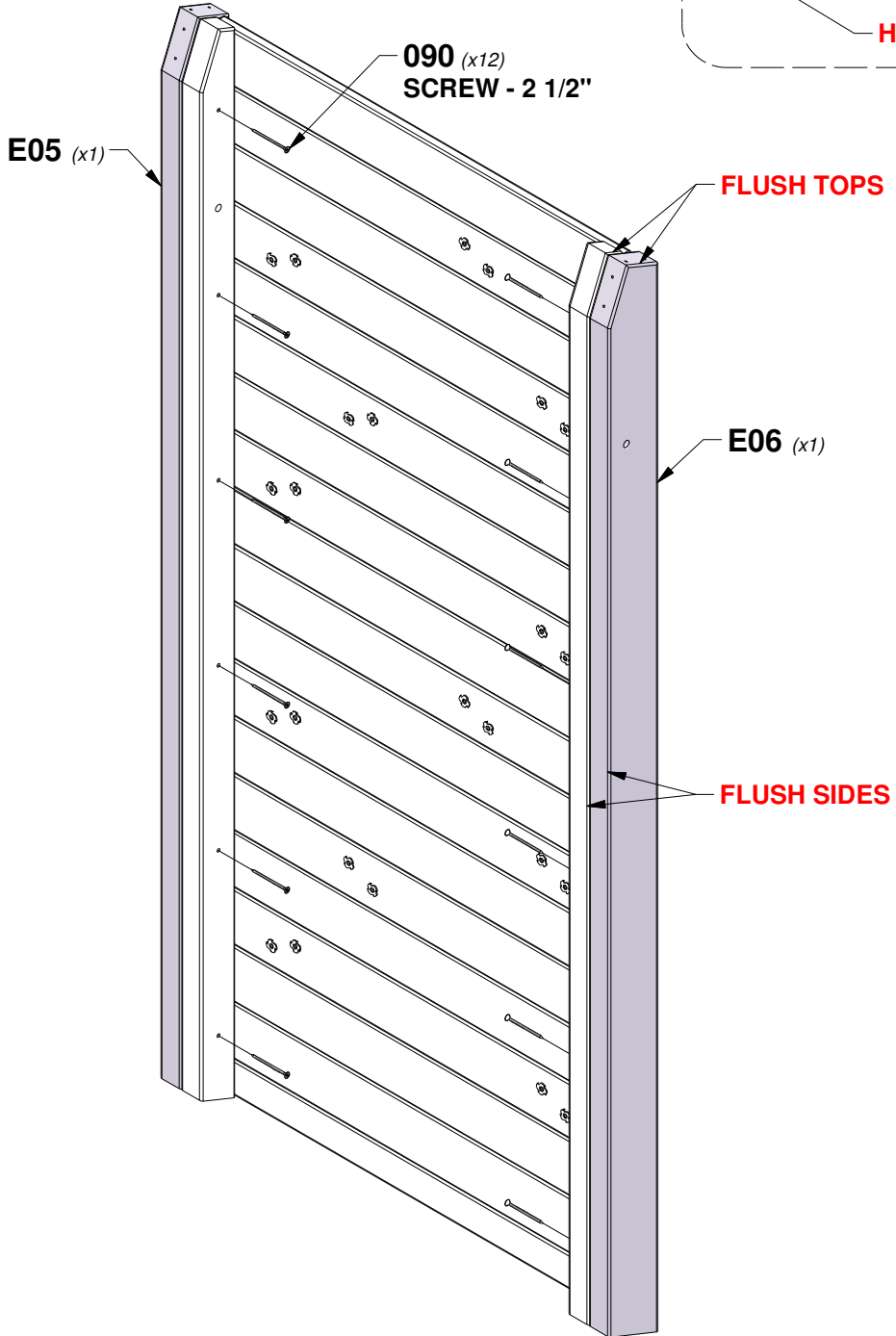
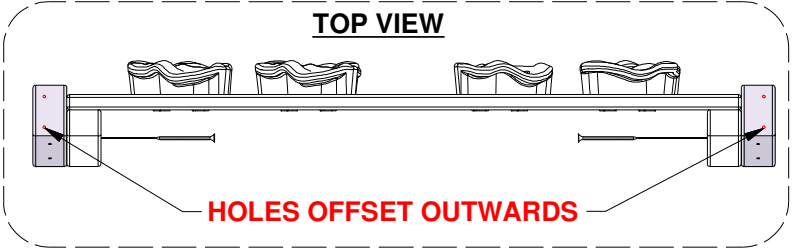

STEP 4 - ROCK WALL

QTY	PART NUMBER	DESCRIPTION
17	H100088	SCREW PFH 8x1-1/8"

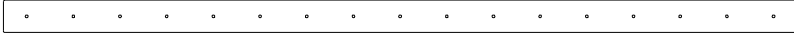

N01 CLEAT - W4L16674
(x1) 5/8"x2 3/8"x57 7/8" (16x60x1470)

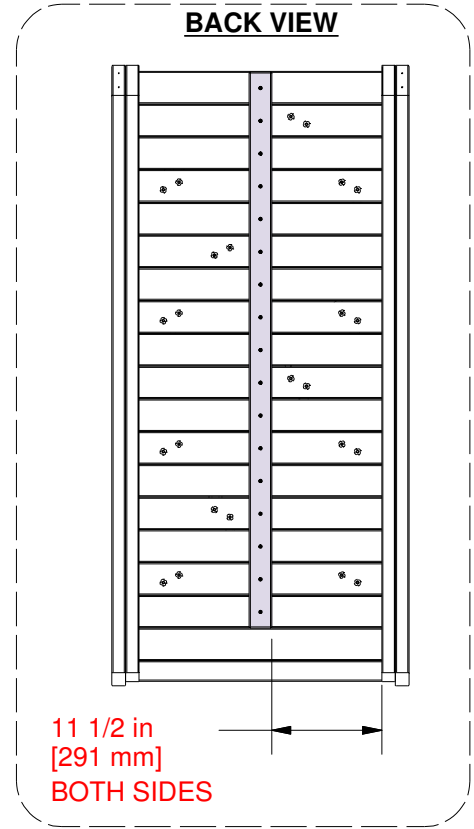
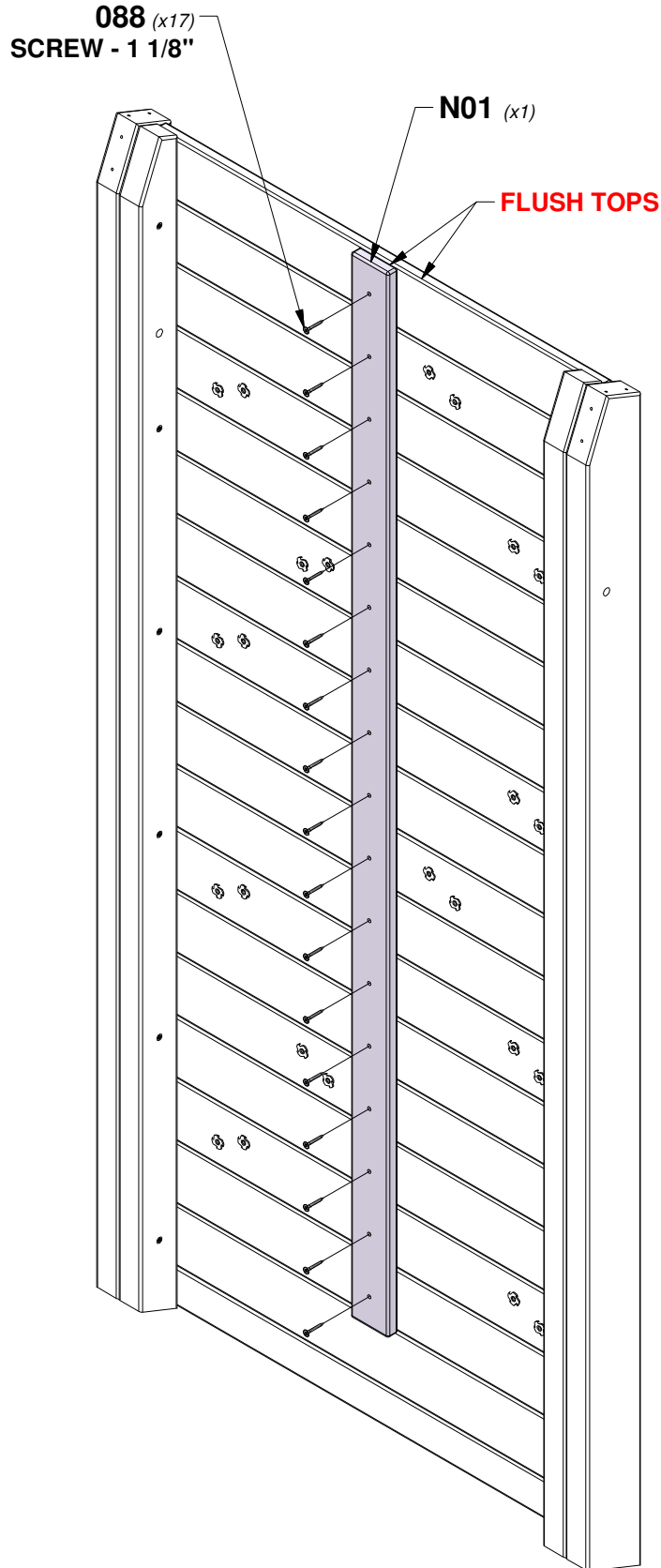

STEP 5 - ROCK WALL

QTY	PART NUMBER	DESCRIPTION
4	H100086	SCREW PFH 8x1-1/2"



M11 TOP BOARD - W4L16668
(x1) 5/8"x3 1/4"x31" (16x82x786)

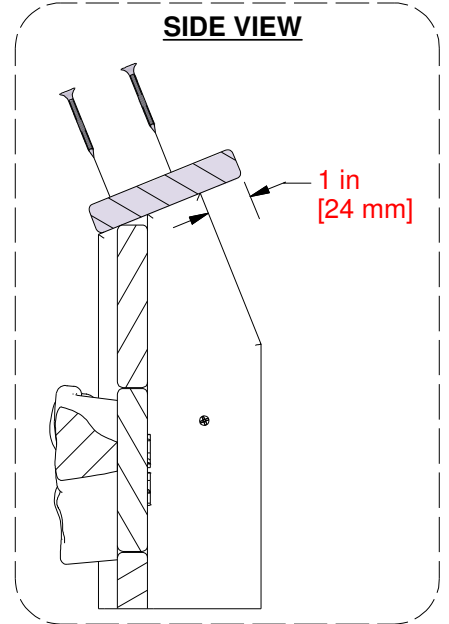
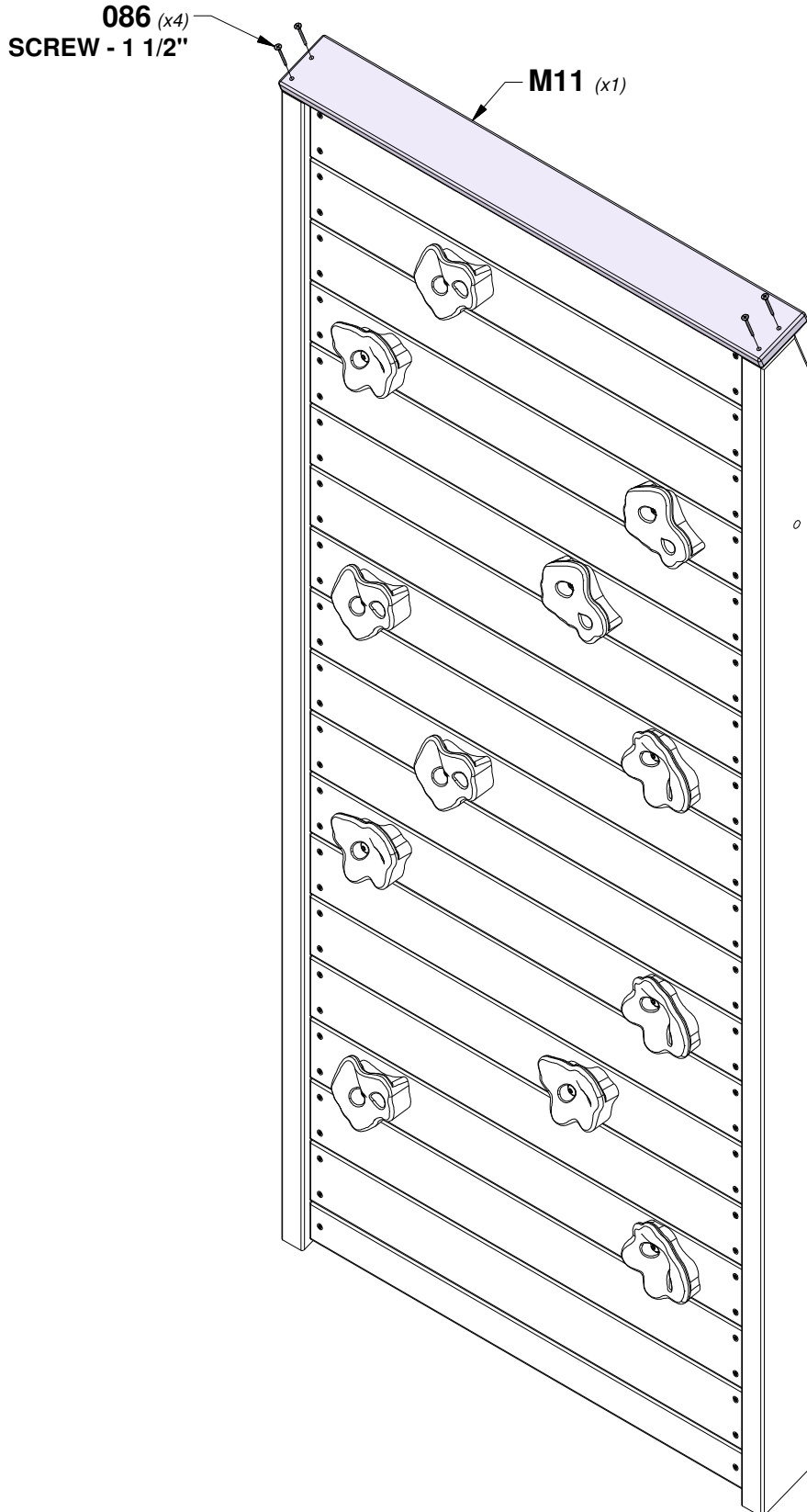

STEP 6 - ROCK WALL

QTY	PART NUMBER	DESCRIPTION
8	H100090	SCREW PFH 8x2 1/2"
2	H100379	T-NUT 5/16 BLK



H14 ATTACHMENT BOARD - W4L16667
 (x1) 1"x3 3/8"x31" (24x86x786)

TIP:
INSTALL T-NUTS IN WOOD FIRST

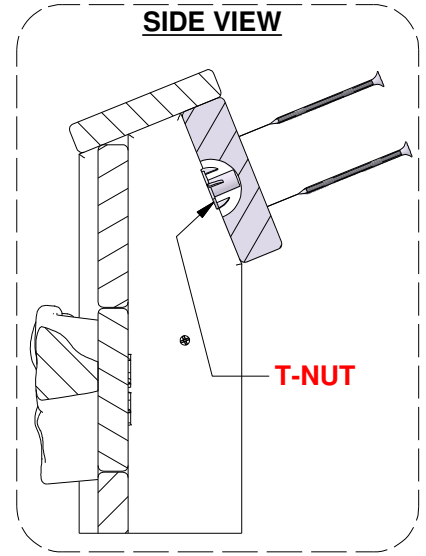
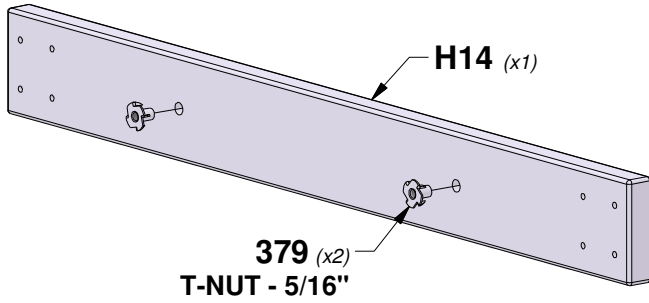

STEP 1 - ROPE WALL

QTY	PART NUMBER	DESCRIPTION
72	H100111	SCREW PFH 8x2

F07 SUPPORT RAIL - W4L16677
 (x2) 1 3/8"x2 3/8"x64 1/8" (36x60x1629)

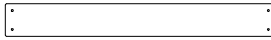

H15 ROPE WALL BOARD - W4L16678
 (x8) 1"x3 3/8"x28 1/8" (24x86x714)

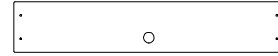
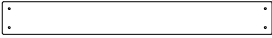

M14 ROCK WALL BOARD - W4L16669
 (x9) 5/8"x3 3/8"x28 1/8" (16x86x714)

G11 ROPE WALL BOARD - W4L18637
 (x1) 1"x5 1/4"x28 1/8" (24x134x714)

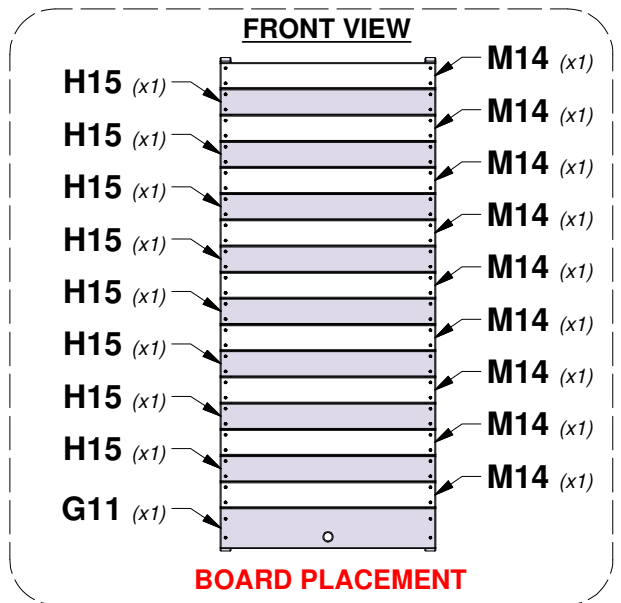
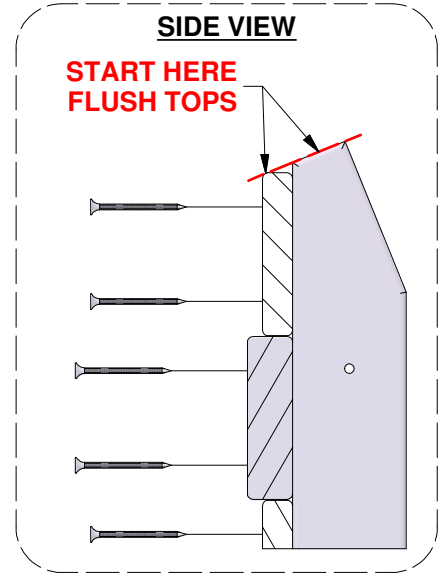
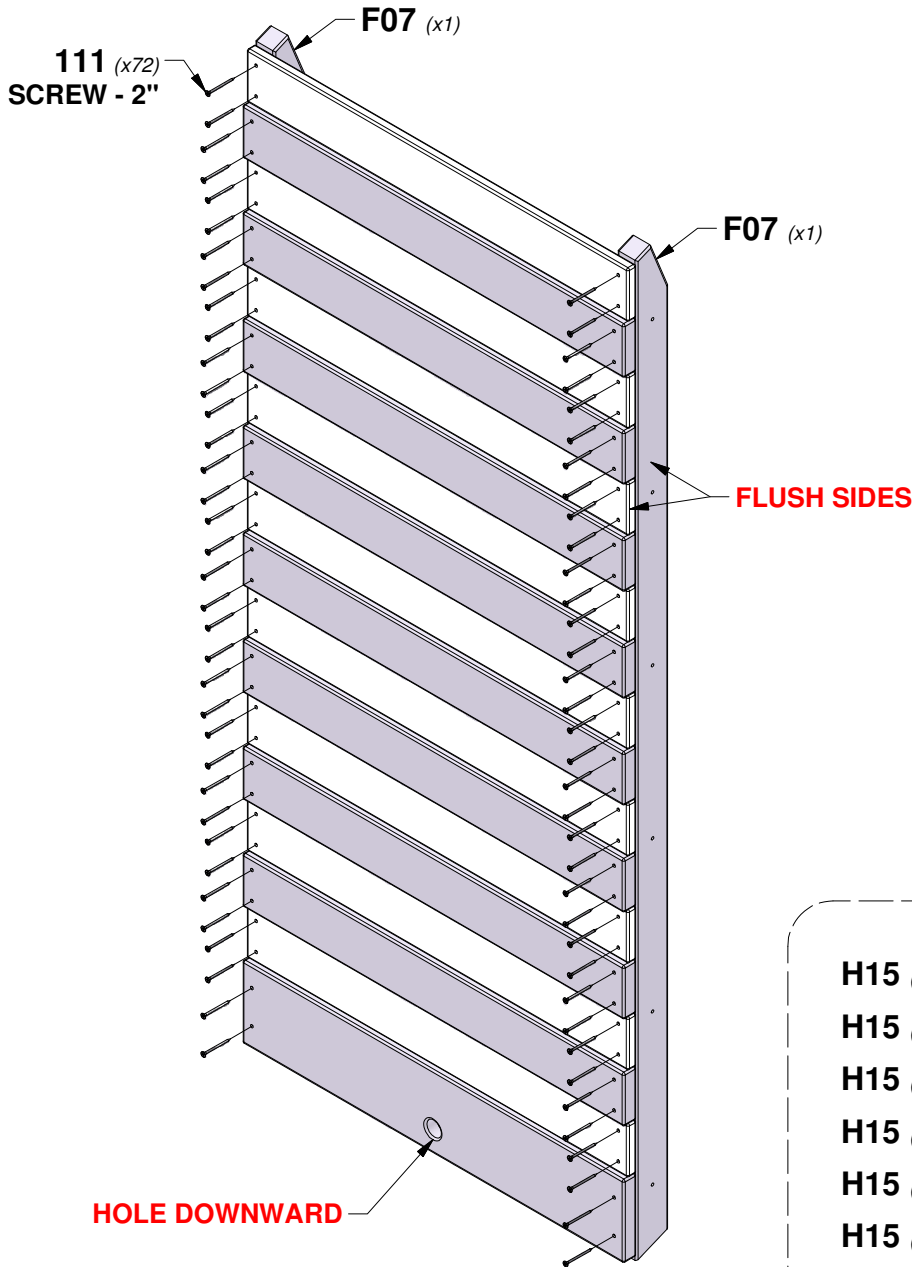

STEP 2 - ROPE WALL

QTY	PART NUMBER	DESCRIPTION
12	H100090	SCREW PFH 8x2 1/2

E07 LEFT RAIL - W4L16675
(x1) 1 3/8"x3 3/8"x64 1/2" (36x86x1640)

E08 RIGHT RAIL - W4L16676
(x1) 1 3/8"x3 3/8"x64 1/2" (36x86x1640)

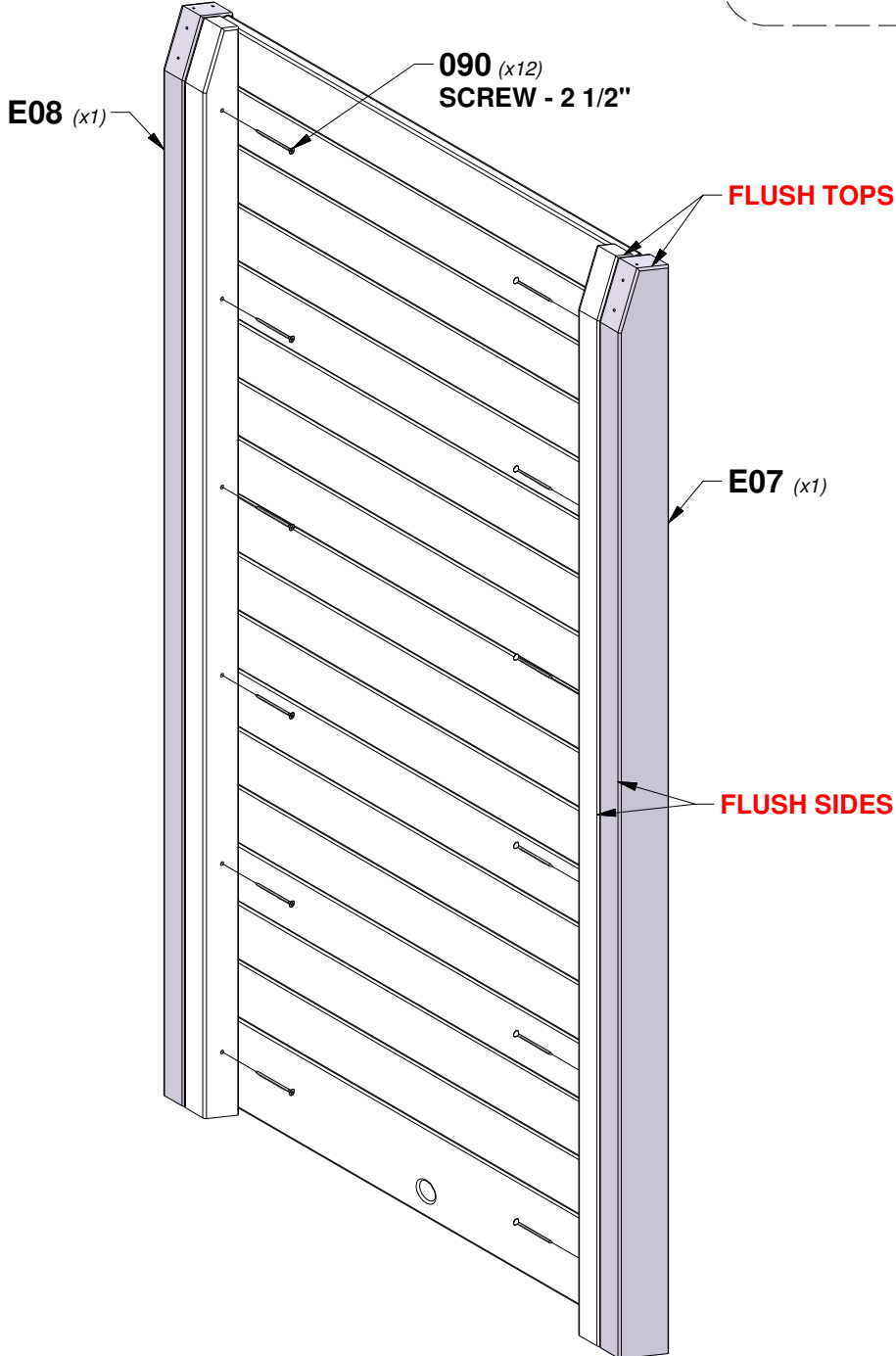
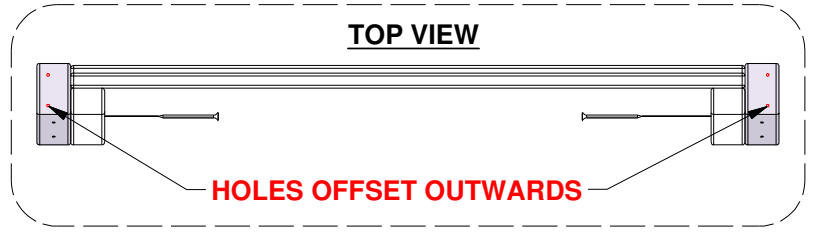

STEP 3 - ROPE WALL

QTY	PART NUMBER	DESCRIPTION
17	H100088	SCREW PFH 8x1-1/8"



N01 CLEAT - W4L16674
(x1) 5/8"x2 3/8"x57 7/8" (16x60x1470)

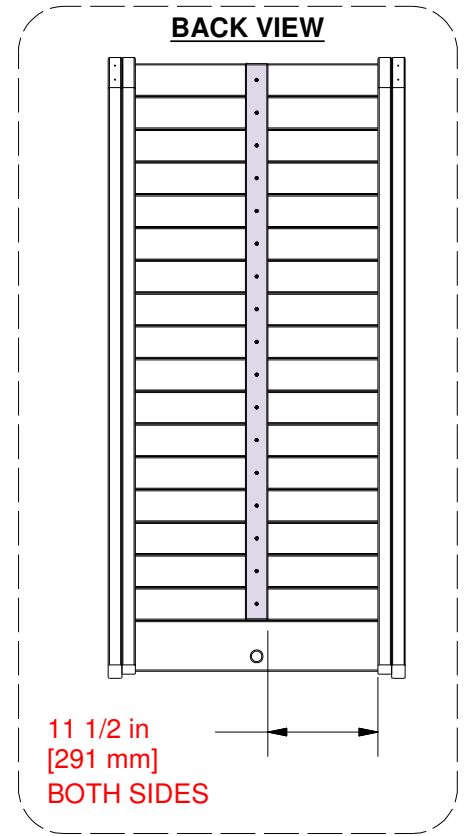
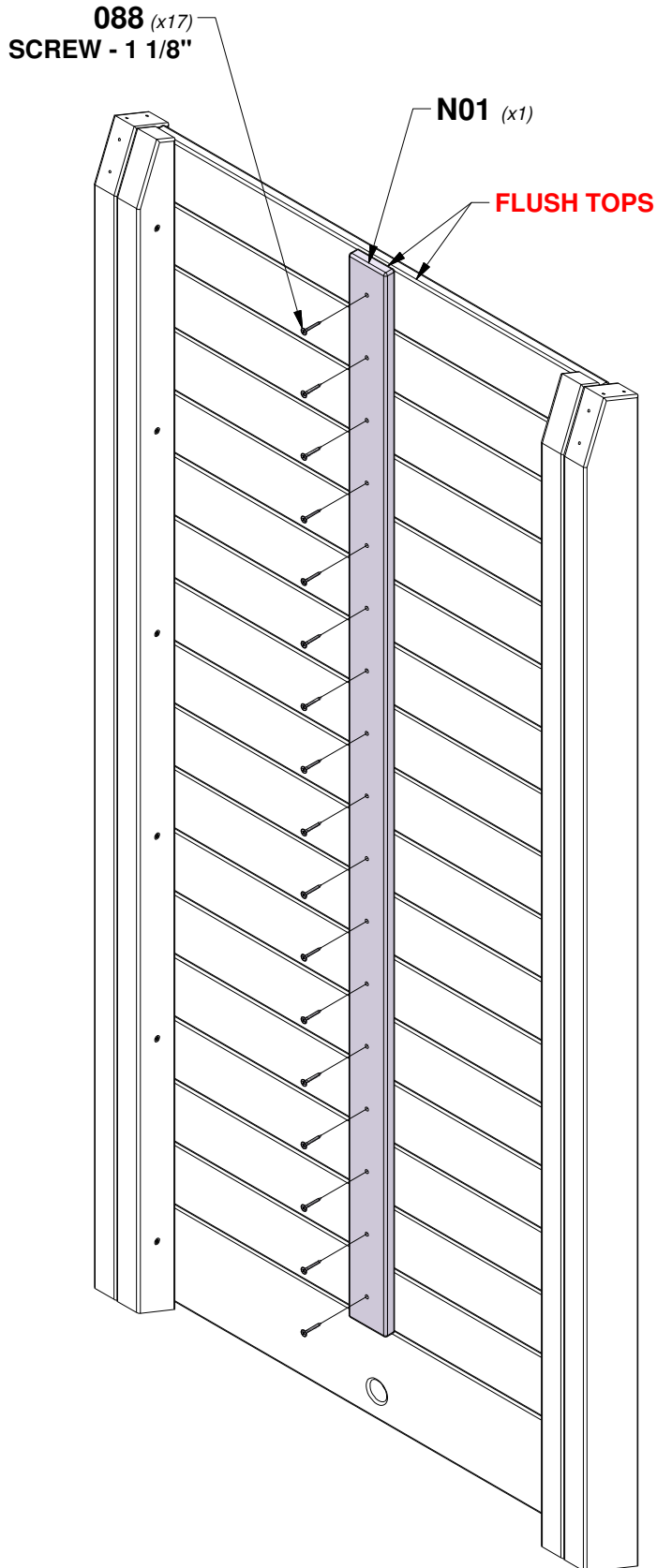

STEP 4 - ROPE WALL

QTY	PART NUMBER	DESCRIPTION
4	H100086	SCREW PFH 8x1-1/2"



M11 TOP BOARD - W4L16668
(x1) 5/8"x3 1/4"x31" (16x82x786)

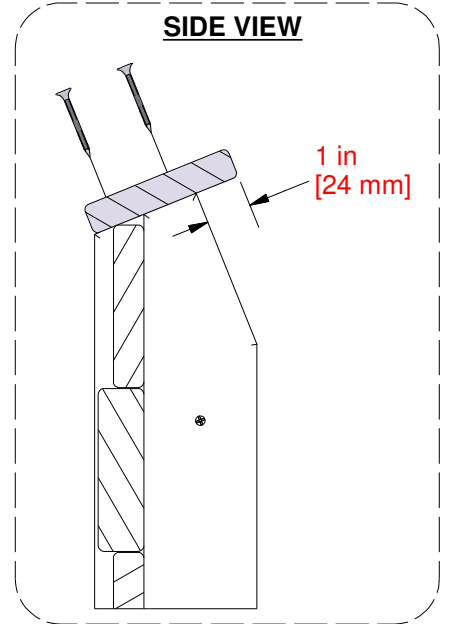
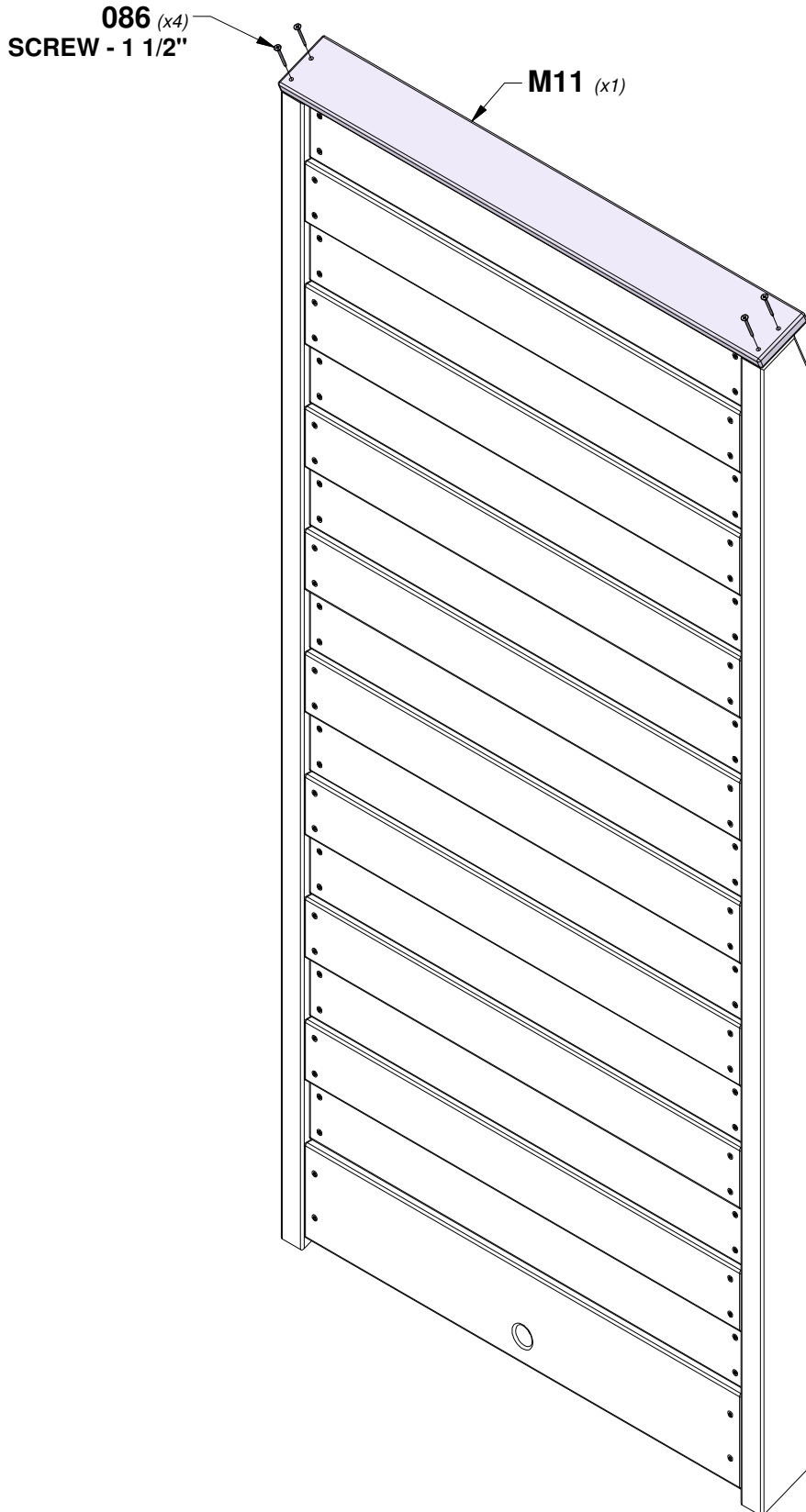

STEP 5 - ROPE WALL

QTY	PART NUMBER	DESCRIPTION
8	H100090	SCREW PFH 8x2 1/2"
2	H100379	T-NUT 5/16 BLK



H17 ATTACHMENT BOARD - W4L16680
 (x1) 1"x3 3/8"x31" (24x86x786)

HOLES DOWNWARD

**TIP:
 INSTALL T-NUTS IN WOOD FIRST**

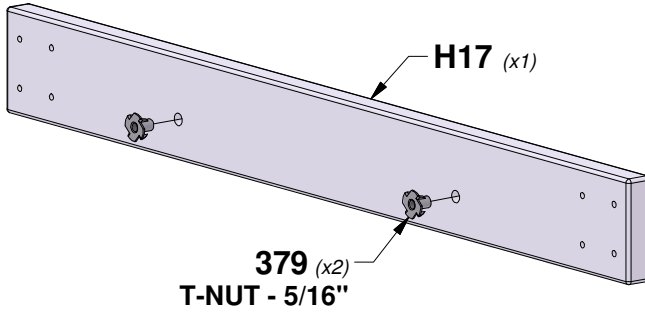

**379 (x2)
 T-NUT - 5/16"**

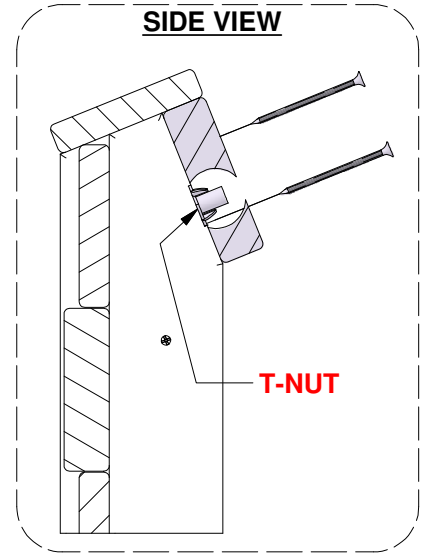

SIDE VIEW

T-NUT

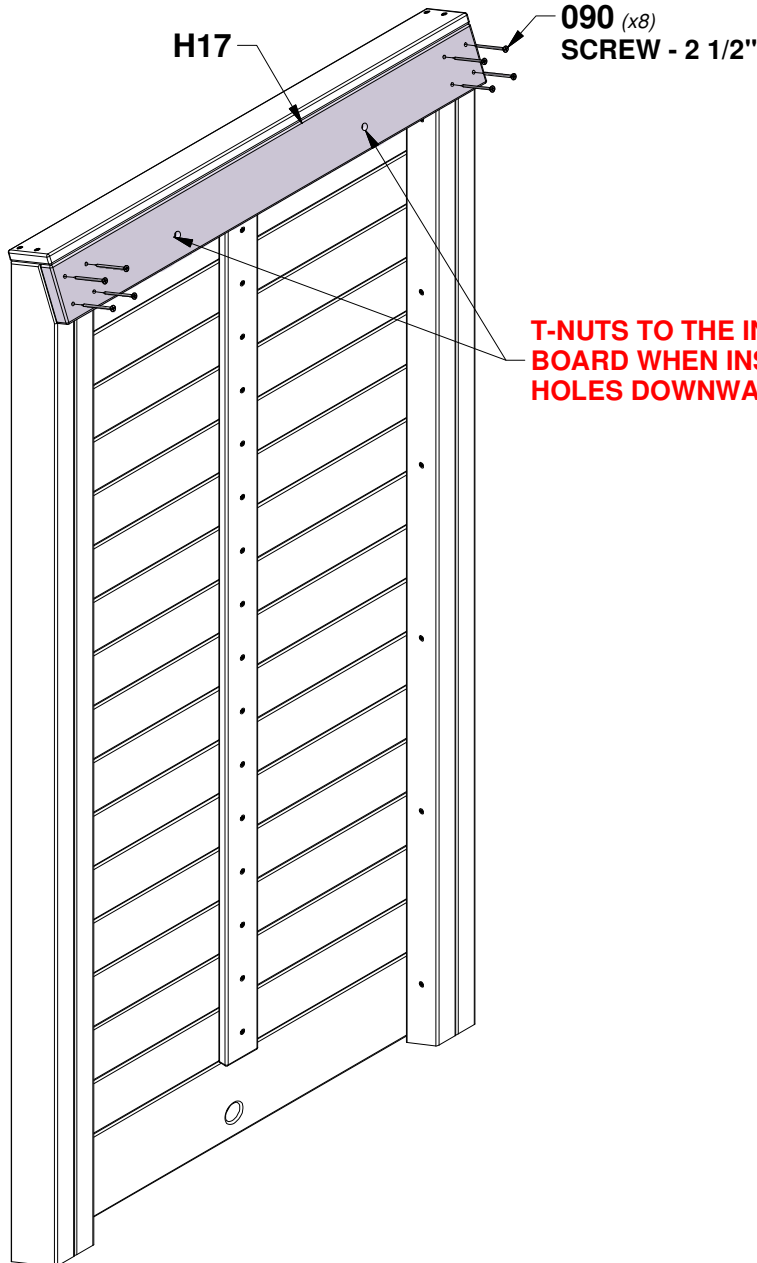

**090 (x8)
 SCREW - 2 1/2"**

**T-NUTS TO THE INSIDE OF
 BOARD WHEN INSTALLED.
 HOLES DOWNWARD.**

STEP 1 - LADDER

QTY	PART NUMBER	DESCRIPTION
10	H100111	SCREW PFH 8x2

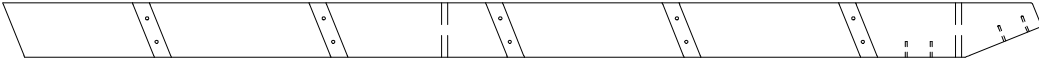

E77 LEFT UPRIGHT - W4L16617
(x1) 1 3/8"x3 3/8"x65" (36x86x1650)



H76 LADDER RUNG - W4L16619
(x5) 1"x3 3/8"x18 1/8" (24x86x460)

TIP:
ALIGN PILOT HOLES

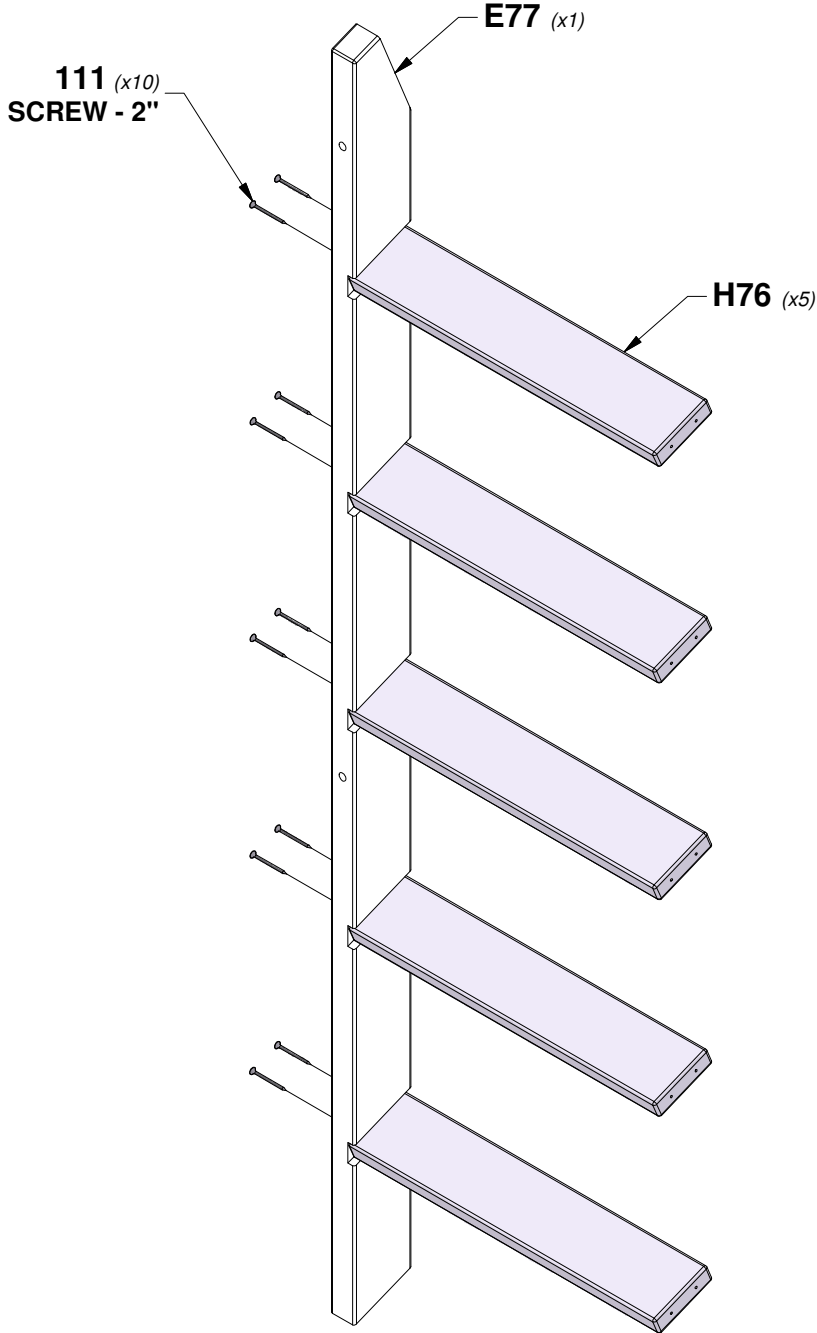

STEP 2 - LADDER

QTY	PART NUMBER	DESCRIPTION
10	H100111	SCREW PFH 8x2

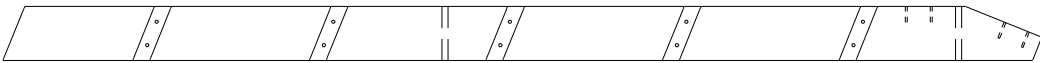

E78 RIGHT UPRIGHT - W4L16618
(x1) 1 3/8"x3 3/8"x65" (36x86x1650)

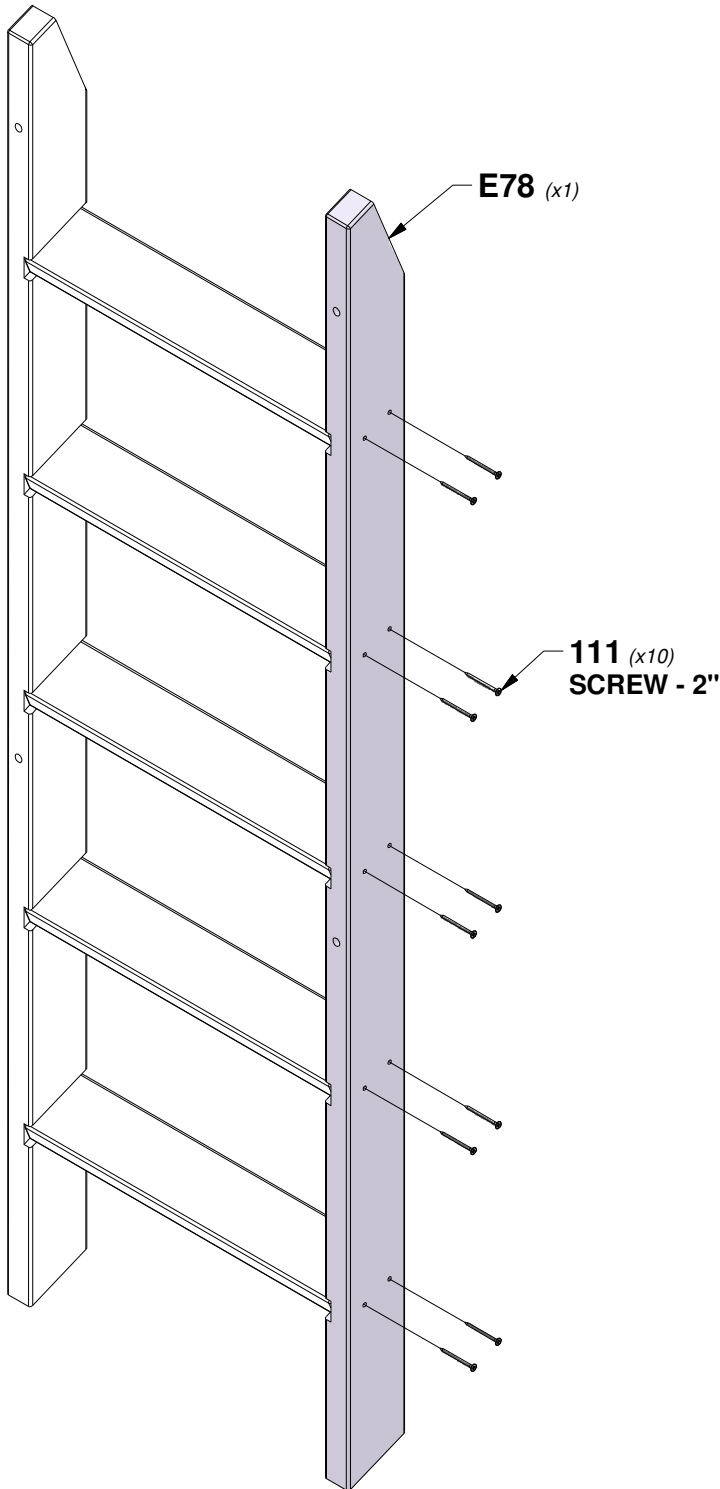

STEP 3 - LADDER

QTY	PART NUMBER	DESCRIPTION
8	H100111	SCREW PFH 8x2



H77 ATTACHMENT BOARD - W4L16620
(x1) 1"x3 3/8"x20 1/8" (24x86x512)



M73 REAR SUPPORT - W4L16621
(x1) 5/8"x3 3/8"x20 1/8" (16x86x512)

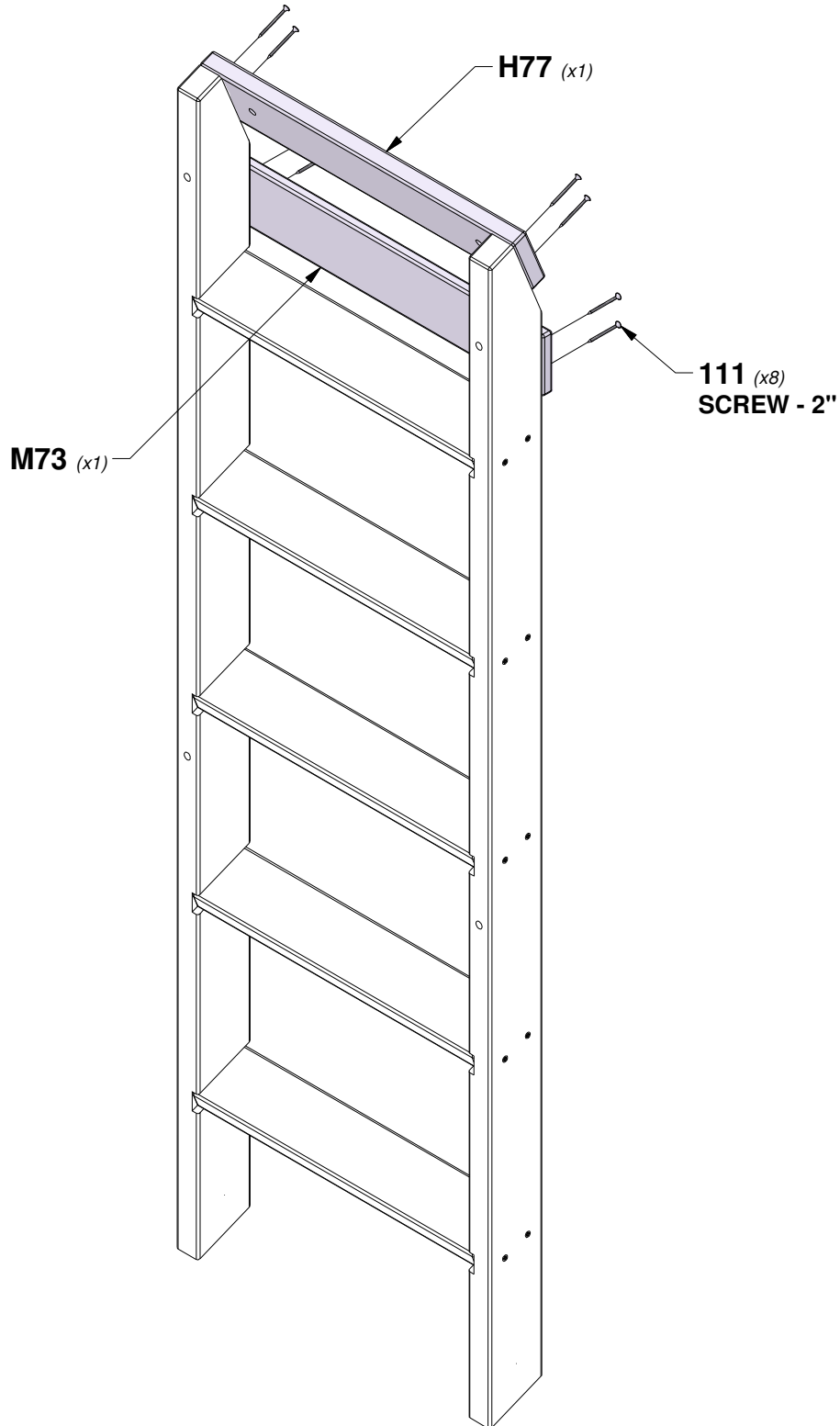

STEP 4 - LADDER

QTY	PART NUMBER	DESCRIPTION
4	H100379	T-NUT 5/16 BLK
4	H100503	BOLT WH 5/16x3-1/2 BLK



TIP:
INSTALL T-NUTS IN WOOD FIRST

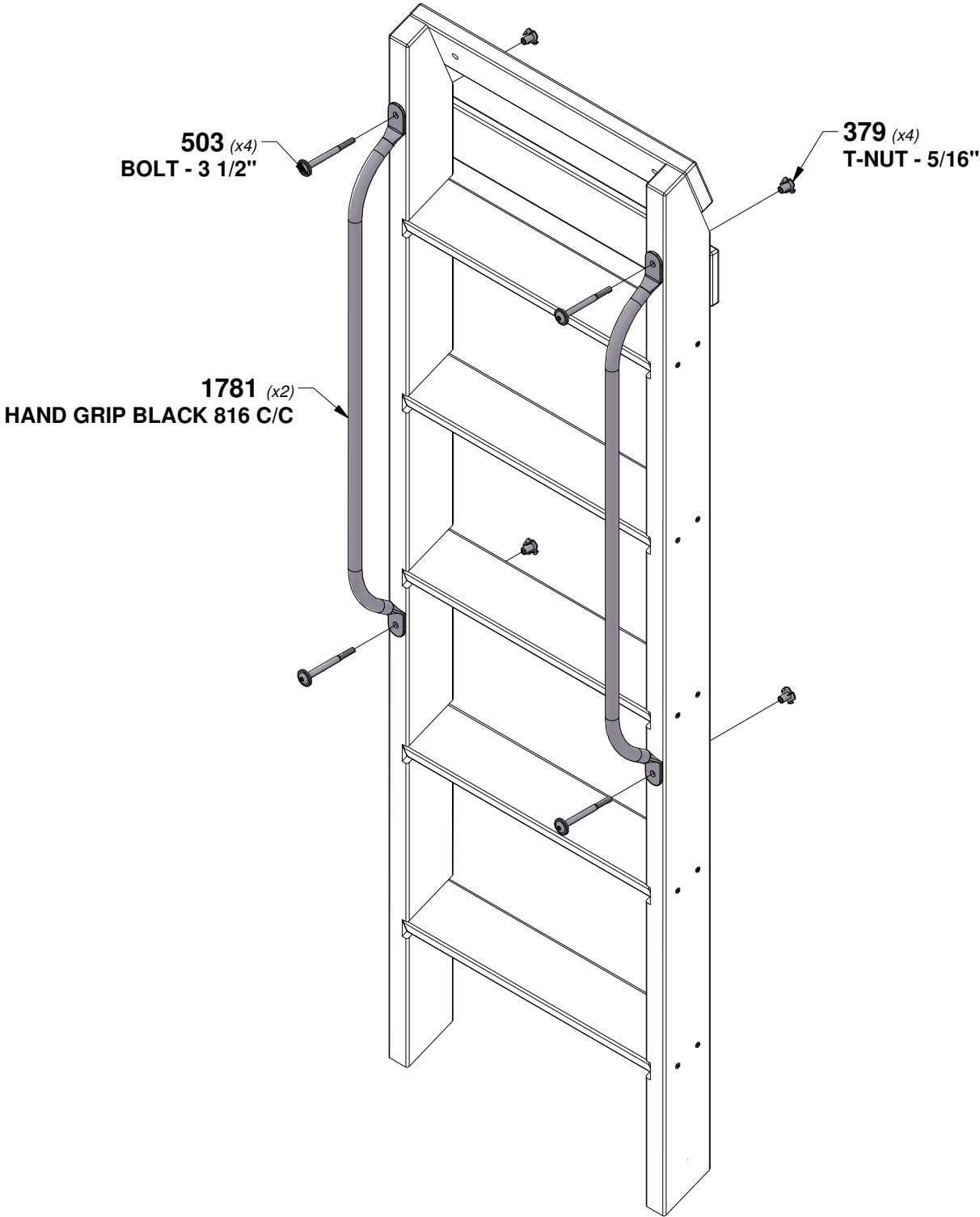

STEP 1 - SWING BEAM



A50 SWING BEAM - W4L16694
(x1) 3 3/8"x5 1/4"x89 1/2" (86x134x2274)



A4M00619 L BRACKET
(x2) 66x66x127 - BLK

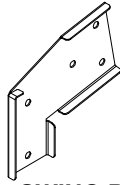

A4M00617 SWING BEAM EXTENSION BRACKET-LEFT
(x1)

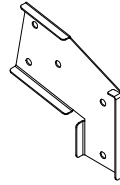

A4M00618 SWING BEAM EXTENSION BRACKET-RIGHT
(x1)

QTY	PART NUMBER	DESCRIPTION
3	H100192	NUT BARREL WH 5/16x7/8 BLK
3	H100416	BOLT WH 5/16x3 BLK
2	H100476	BOLT HEX 5/16x4 1/4 BLK
4	H100478	WASHER FLAT 8x27 BLK
2	H100479	NUT LOCK 5/16 BLK

TIP:
LEAVE 416 BOLTS & 192 NUT BARRELS HAND TIGHT.

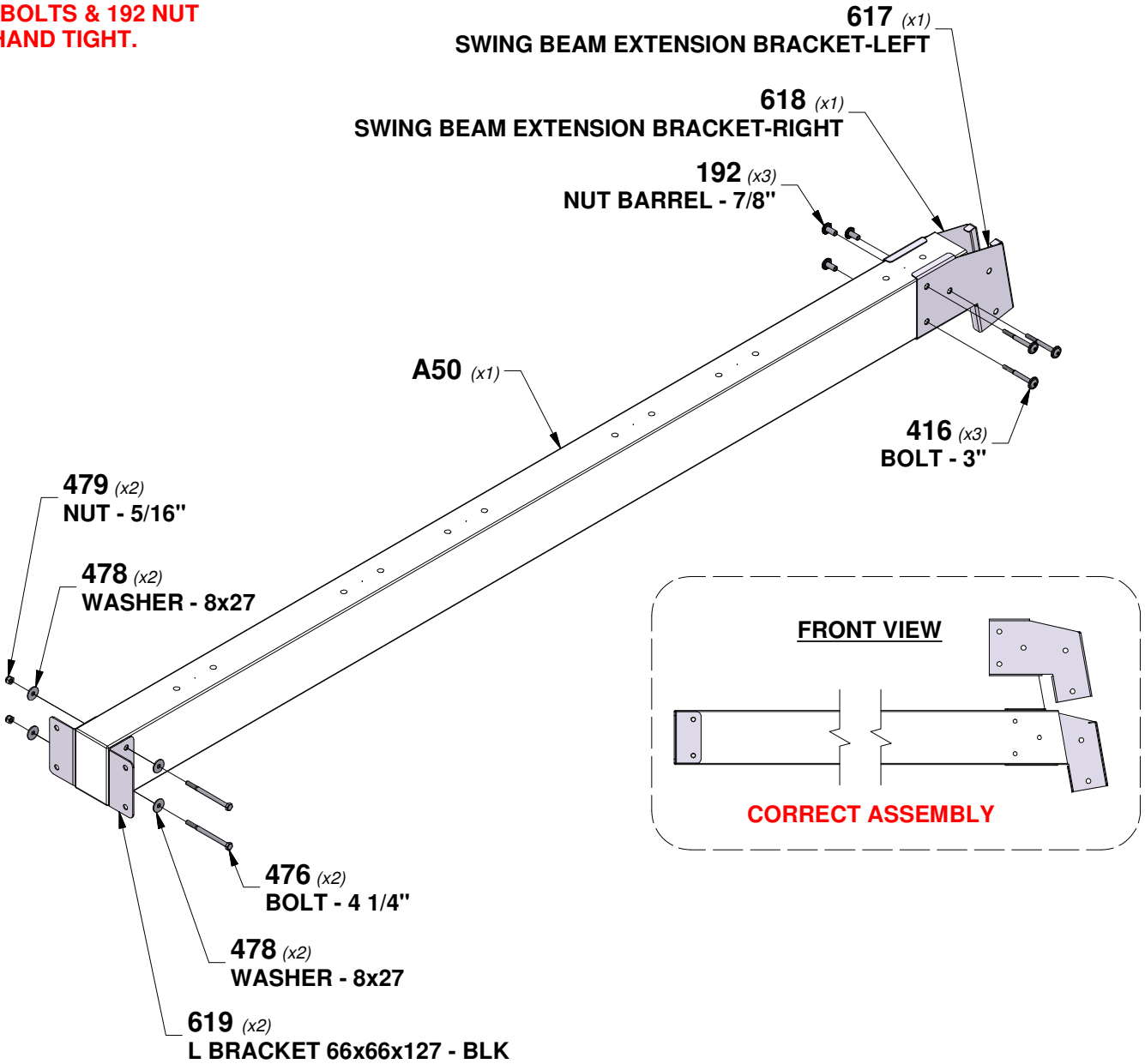

STEP 2 - SWING BEAM

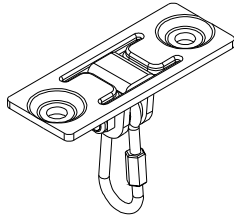

A4M00505
(x6) **SWING HANGER**

QTY	PART NUMBER	DESCRIPTION
12	H100073	T-NUT 3/8
12	H100102	WASHER FLAT 11x25
12	H100107	WASHER LOCK INT 10x18
12	H100654	BOLT HEX 3/8x5-1/2

TIP:
INSTALL T-NUTS IN WOOD FIRST

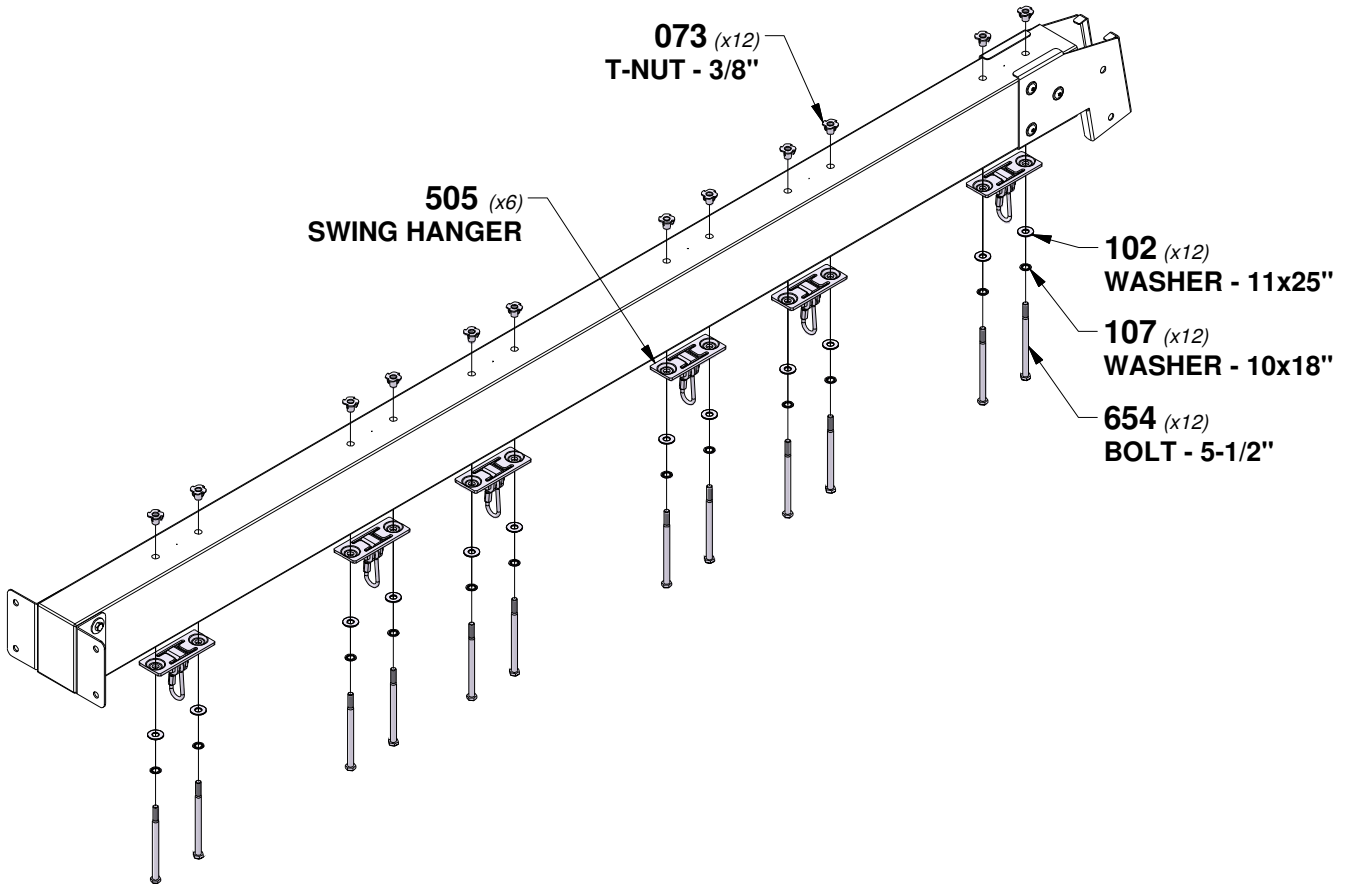

STEP 3 - SWING BEAM

QTY	PART NUMBER	DESCRIPTION
4	H100128	SCREW PWH 8x5/8



A100164 BYD ID TAG
(x1) (LARGE) AGES
3-10

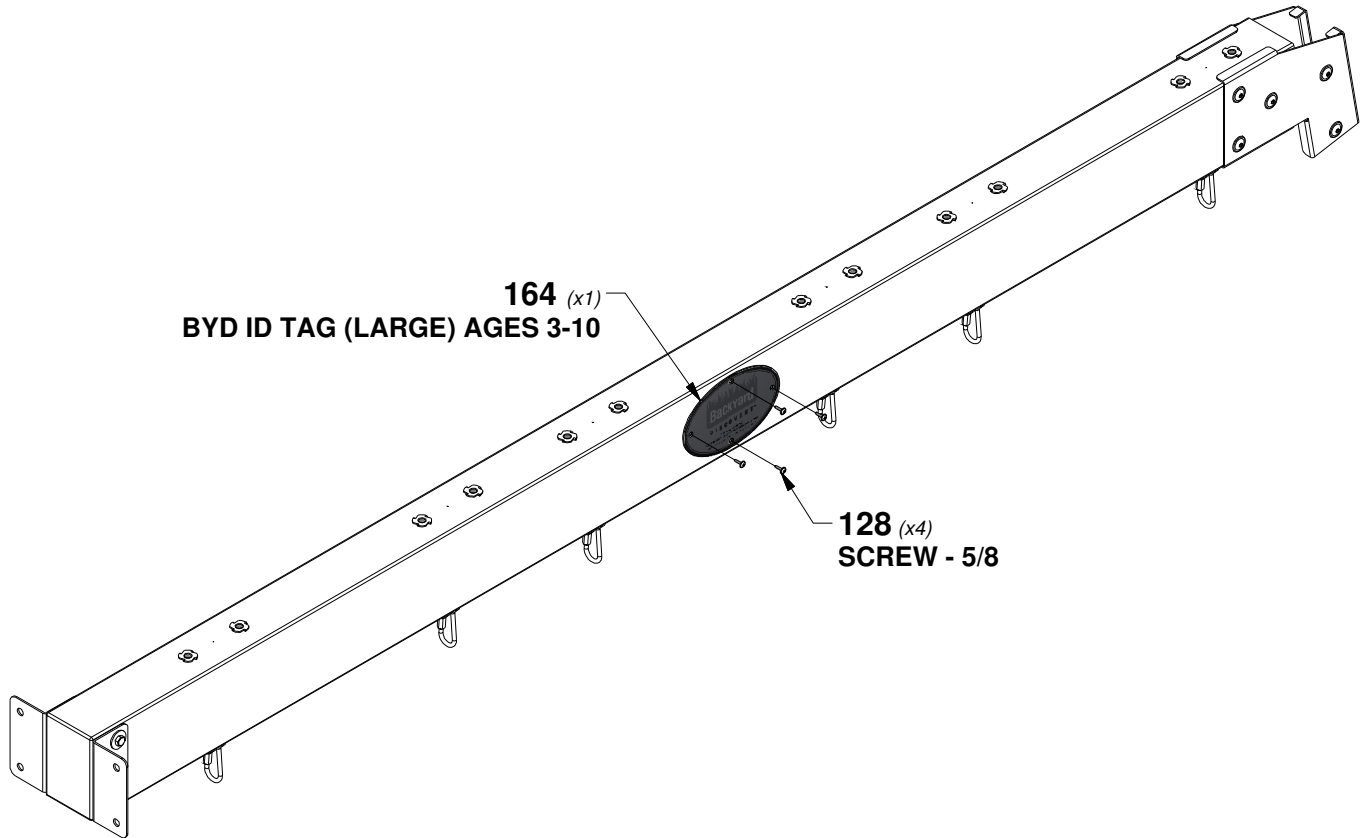
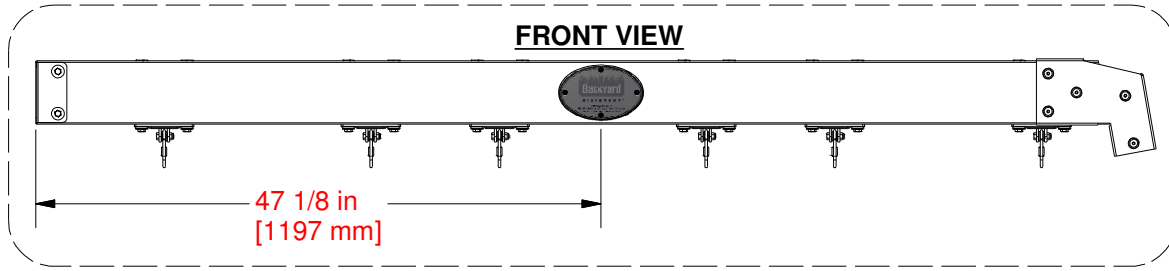

STEP 4 - SWING BEAM

QTY	PART NUMBER	DESCRIPTION
6	H100379	T-NUT 5/16 BLK
4	H100407	BOLT WH 5/16x1 1/2 BLK
2	H100503	BOLT WH 5/16x3-1/2 BLK

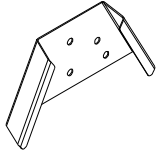

A4M01782 A-FRAME BRACKET
(x1)



SP71 SWING BEAM SUPPORT - W4L16695
(x1) 3 3/8"x3 3/8"x49 1/2" (86x86x1256)

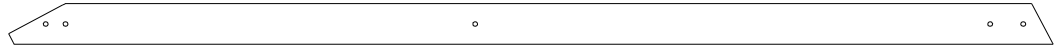

E80 ANGLE BRACE - W4L16696
(x2) 1 3/8"x3 3/8"x87 1/8" (36x86x2212)

TIP:
INSTALL T-NUTS IN WOOD FIRST

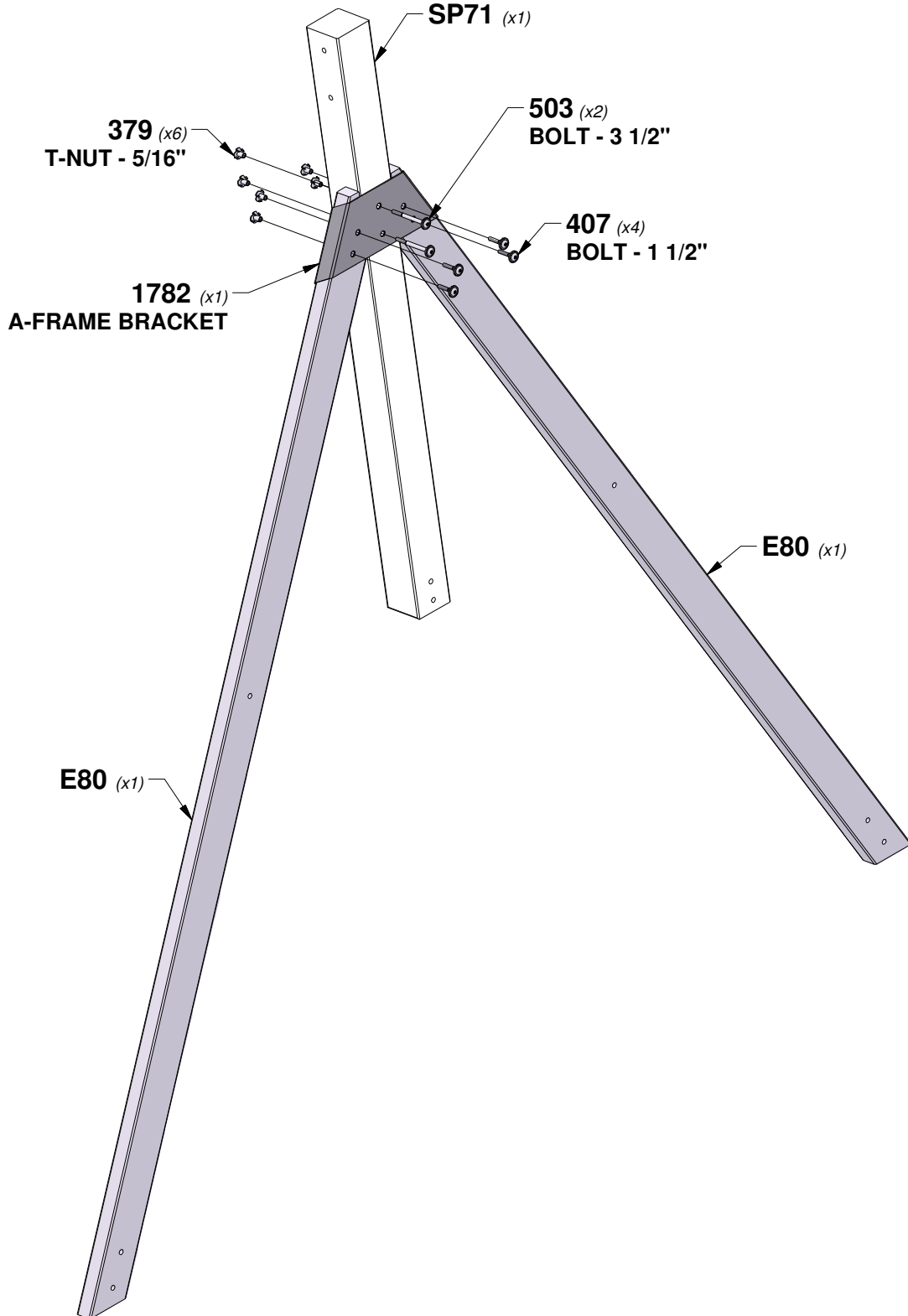

STEP 5 - SWING BEAM

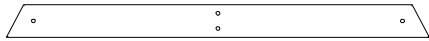

E79 END SUPPORT - W4L16697
(x1) 1 1/2"x3 1/2"x44" (36x86x1120)



G50 GROUND BOARD - W4L16698
(x1) 1"x5 1/4"x86 11/16" (24x134x2202)

QTY	PART NUMBER	DESCRIPTION
2	H100195	BOLT WH 5/16x2-3/4 BLK
8	H100198	WASHER LOCK EXT 8x19 BLK
4	H100205	BOLT WH 5/16x2-1/4 BLK
8	H100379	T-NUT 5/16 BLK
2	H100480	BOLT WH 5/16x4 3/4 BLK

TIP:
INSTALL T-NUTS IN WOOD FIRST

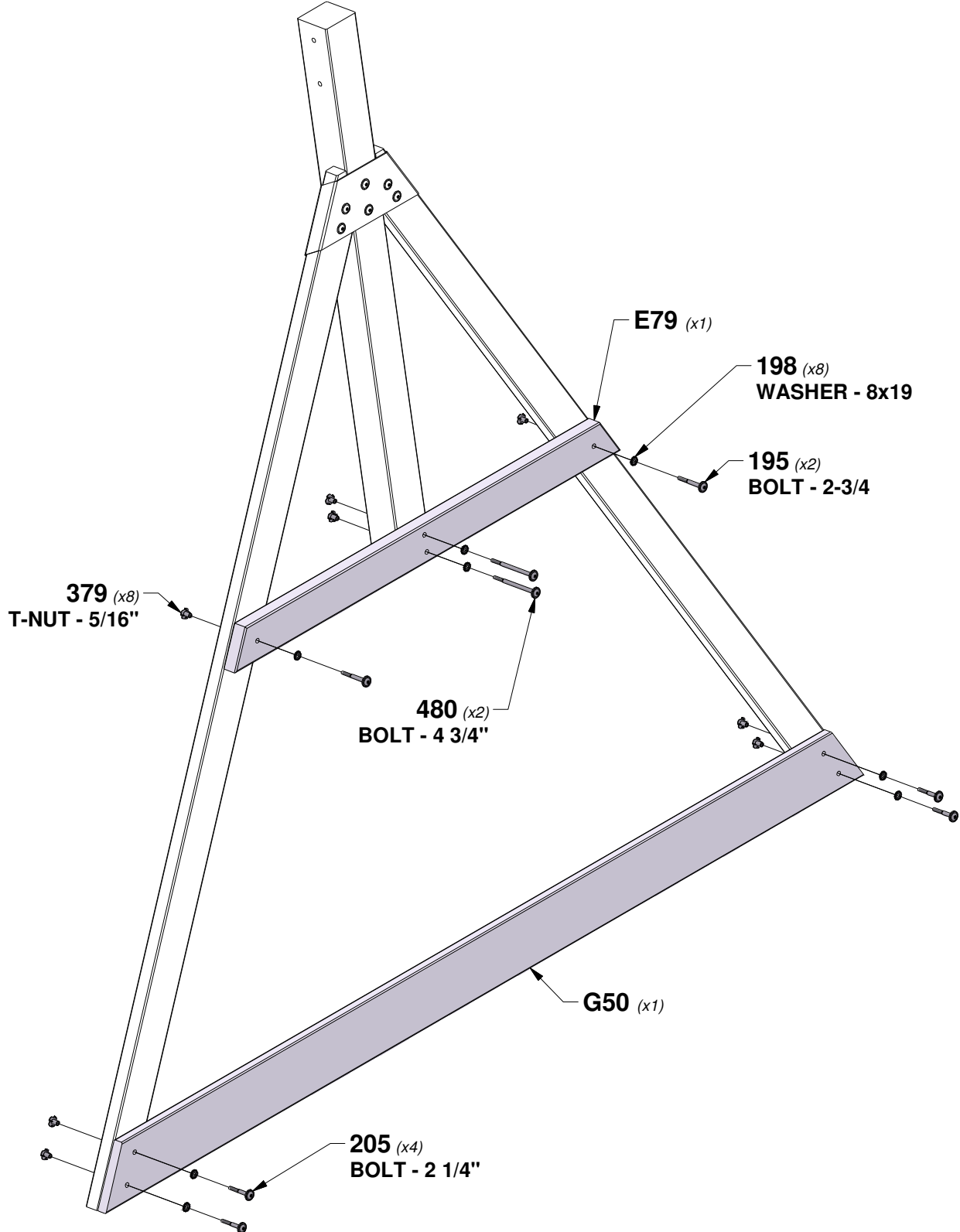

STEP 6 - SWING BEAM

QTY	PART NUMBER	DESCRIPTION
2	H100192	NUT BARREL WH 5/16x7/8 BLK
2	H100416	BOLT WH 5/16x3 BLK

TIP:
TIGHTEN ALL (5) 416 BOLTS & 192 NUT BARRELS NOW.

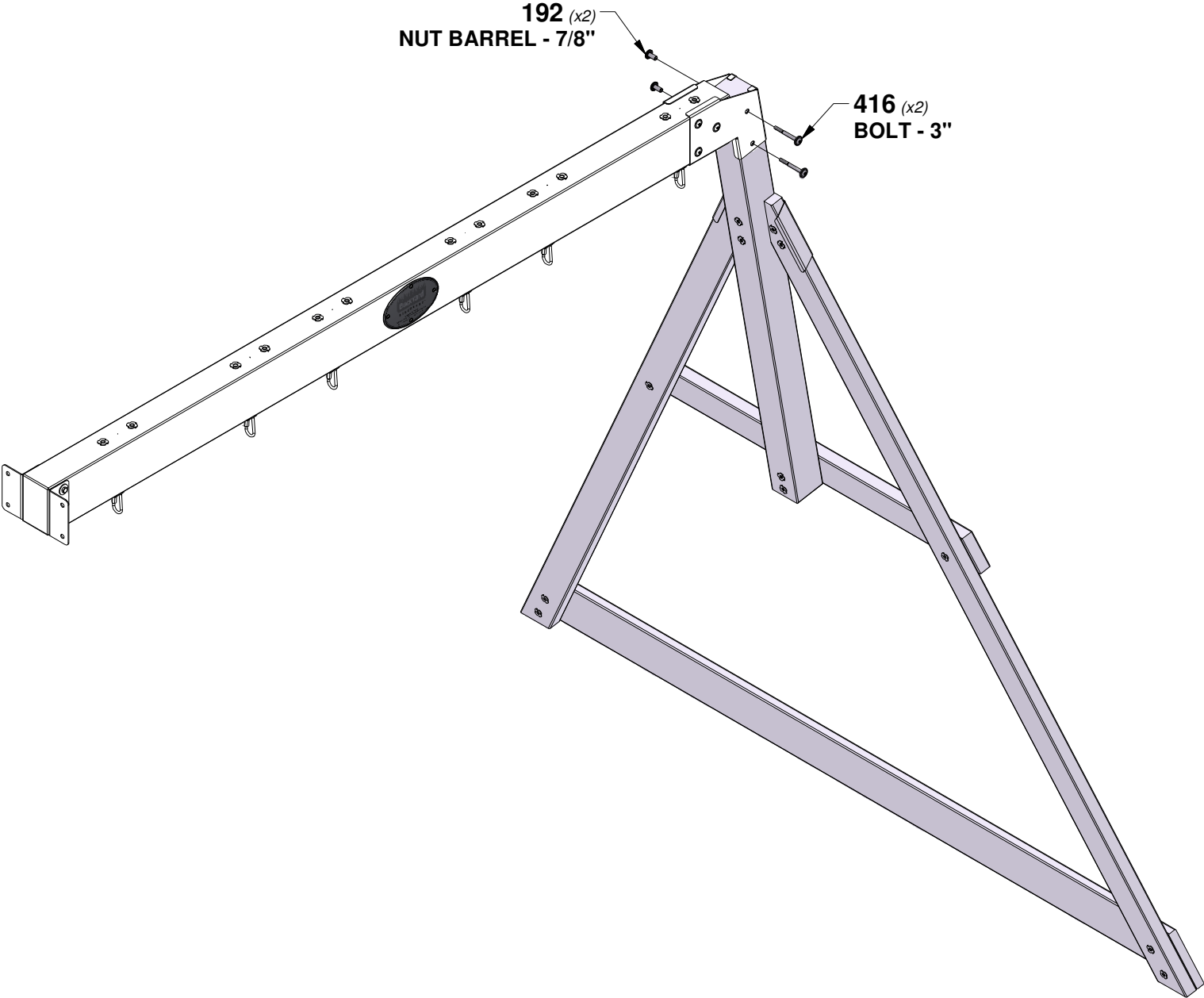

STEP 1 - SLIDE ASSEMBLY

QTY	PART NUMBER	DESCRIPTION
3	H100074	T-NUT 5/16
3	H100115	BOLT WH 5/16x1/2



A6P00385 | SLIDE BED 10' DARK GREEN
(x1)



M70 | SLIDE BED SUPPORT - W100935
(x1) | 5/8"x3 3/8"x19 7/8" (16x86x505)

NOTE:

TAKE NOTE OF SLIDE BED SURFACE FINISH, THE DULL SIDE WILL BE TOWARDS THE GROUND. PLACE SLIDE BRACE CENTERED ON THE BOTTOM (DULL SIDE) AND 1/2" FROM THE EDGE. USE M70 BOARD AS A TEMPLATE FOR DRILLING BOTTOM HOLE PATTERN IN SLIDE BED. USE A 5/16" DRILL BIT.

TOP

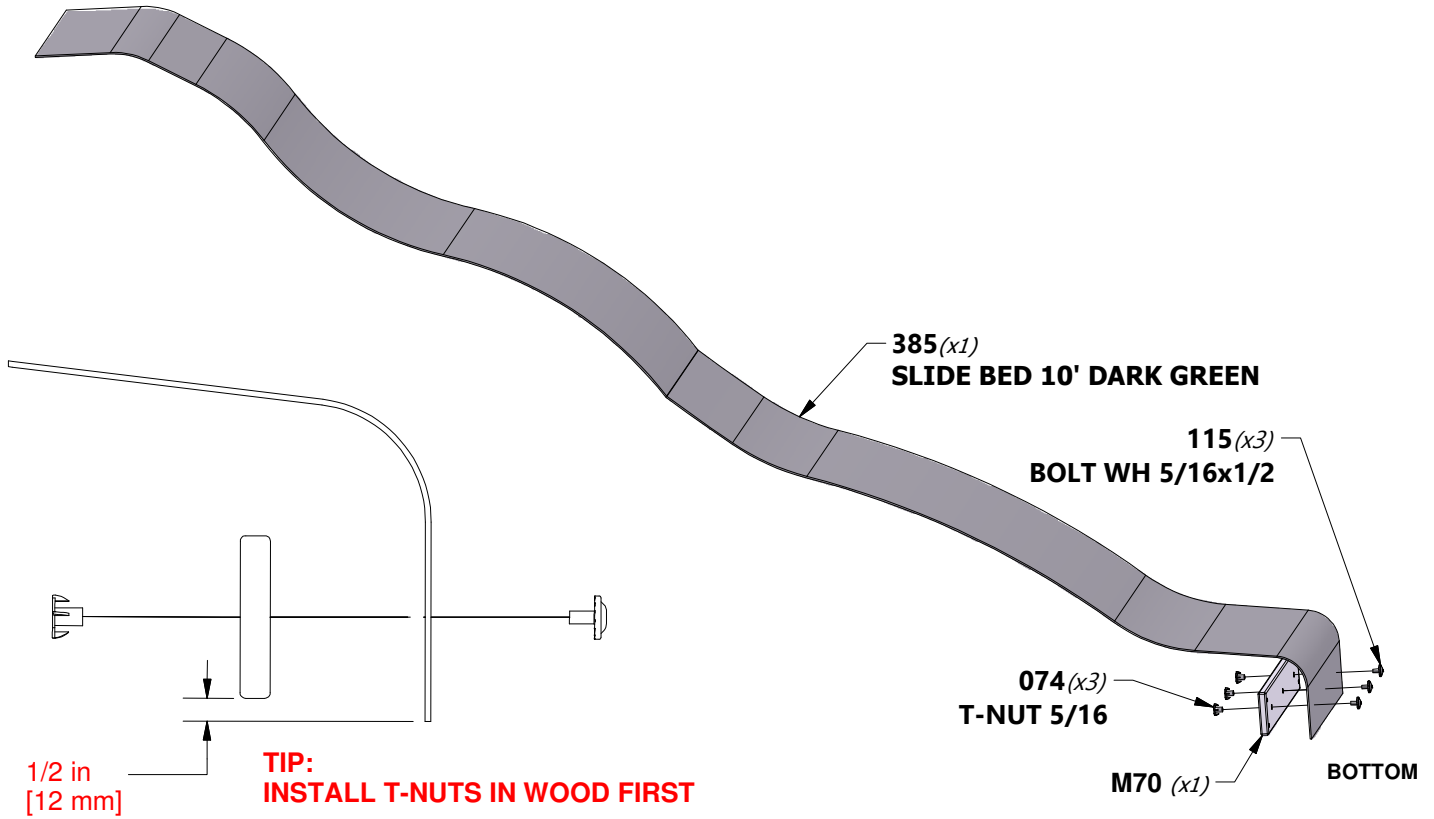

TIP:

PRE-BENDING THE ENDS WILL EASE ASSEMBLY. PLACING THE SLIDE BED OUT IN THE SUN MAKES IT EASIER TO BEND.

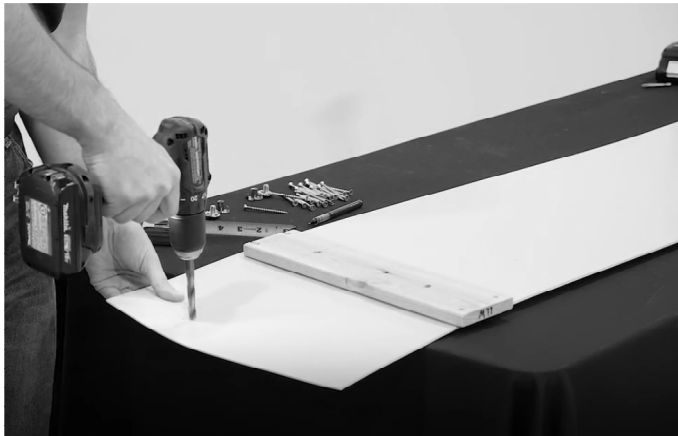

STEP 2 - SLIDE ASSEMBLY

QTY	PART NUMBER	DESCRIPTION
8	H100006	NUT BARREL WH 5/16x1 1/2
8	H100115	BOLT WH 5/16x1/2
6	H100121	SCREW 8x3/4

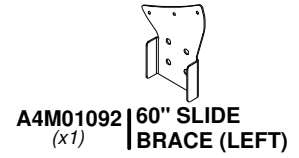
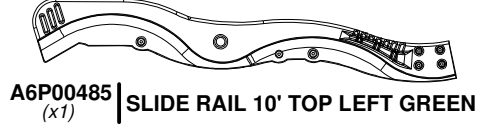
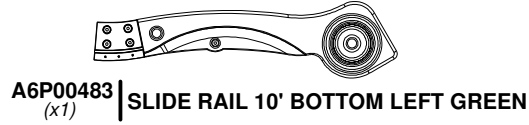
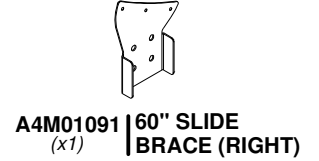
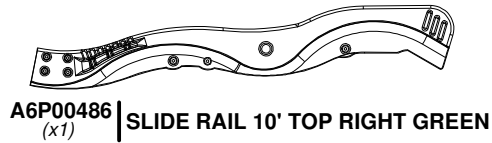

NOTE:
REPEAT ON OTHER SIDE, MAKING
A LEFT AND RIGHT ASSEMBLY.

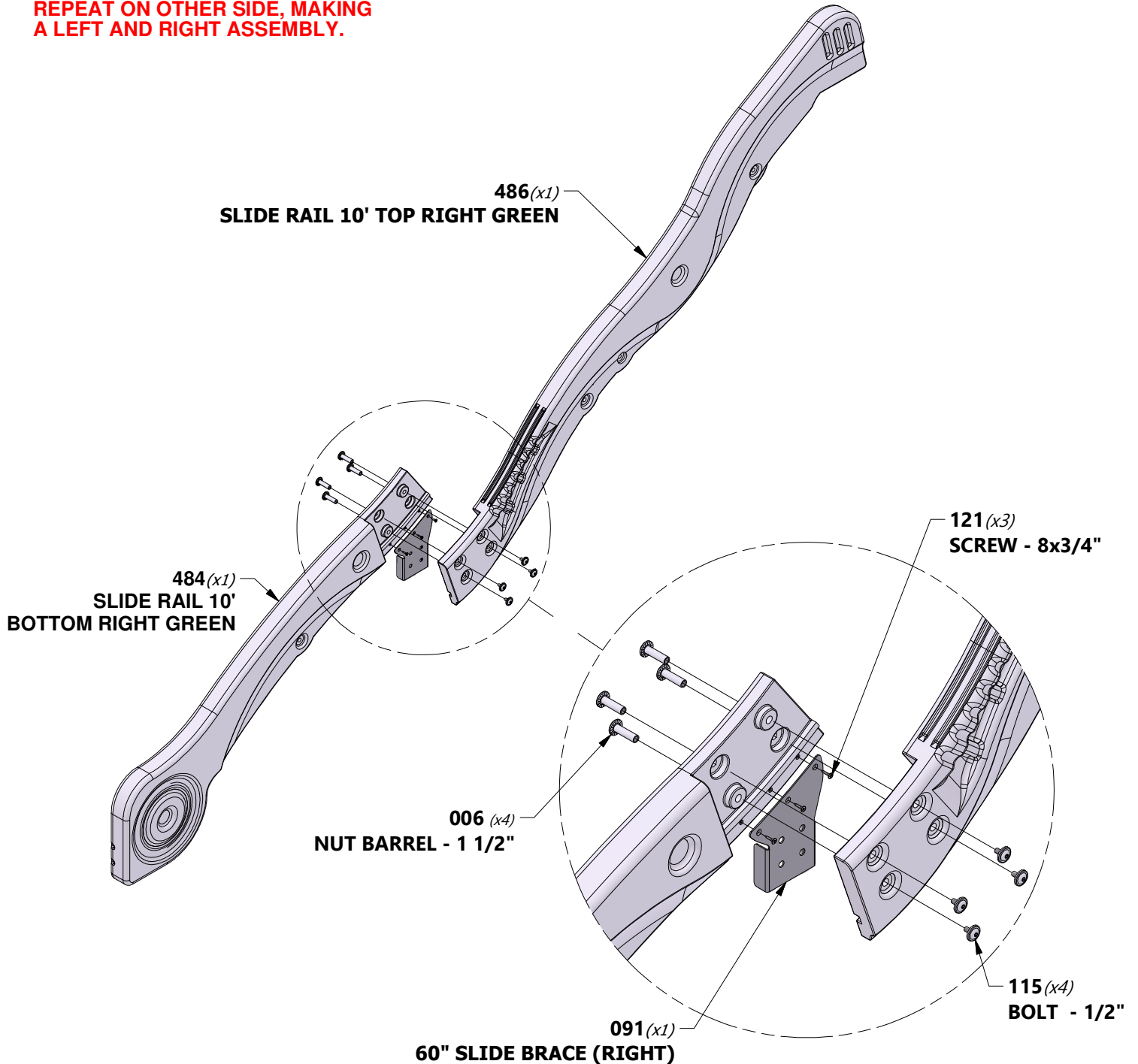

STEP 3 - SLIDE ASSEMBLY

QTY	PART NUMBER	DESCRIPTION
4	H100009	BOLT WH 5/16x1 1/4

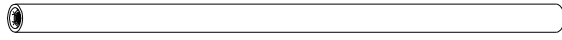

A6P00487
(x4) | SLIDE TUBE SUPPORT

NOTE:
INSERT THE (4) SLIDE SUPPORT TUBES INTO THEIR RESPECTIVE PILOT LOCATIONS (FIGURE 1).

PLACE (1) SLIDE RAIL ASSEMBLY ON A FLAT SURFACE AND BEGIN INSERTING SLIDE BED AT THE BOTTOM OF THE SLIDE RAIL (FIGURE 2). HAVE A HELPER BEND THE SLIDE BED TOWARDS THE TOP OF THE SLIDE AND INSERT THE BED INTO THE SLIDE CAVITY. MAKE SURE SLIDE BED IS INSERTED WITHIN 1/8" (3mm) OF GROOVE BOTTOM.

TIP:
A HELPER IS RECOMMENDED FOR THESE FOLLOWING STEPS.

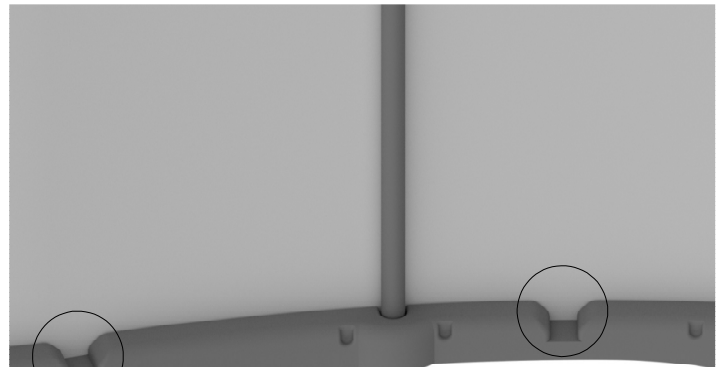
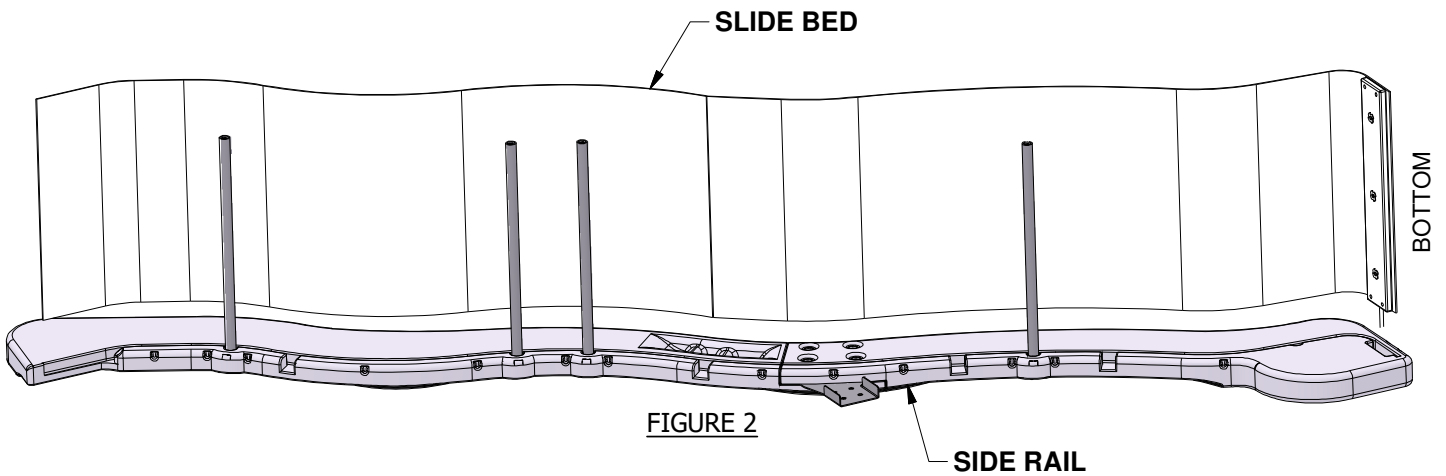
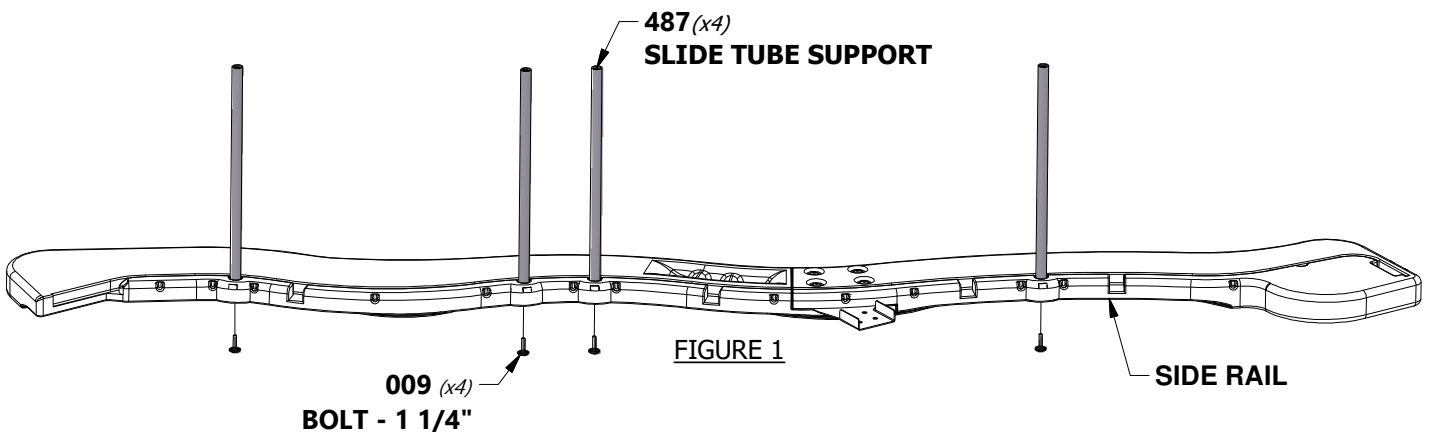

VIEWING WINDOWS

STEP 4 - SLIDE ASSEMBLY

NOTE:
PLACE SECOND SLIDE RAIL ASSEMBLY OVER THE TOP OF THE SLIDE BED AND SLIDE SUPPORT TUBES. INSERT THE SLIDE BED AND SLIDE SUPPORT TUBES INTO THE SLIDE CAVITY. MAKE SURE SLIDE BED IS INSERTED WITHIN 1/8" (3mm) OF GROOVE BOTTOM.



FAILURE TO INSERT SLIDE BED PROPERLY MAY RESULT IN INJURY OR AMPUTATION. EXPOSED SLIDE EDGES CAN BE SHARP AND BECOME A LACERATION HAZARD IF THE SLIDE IS NOT PROPERLY ASSEMBLED.

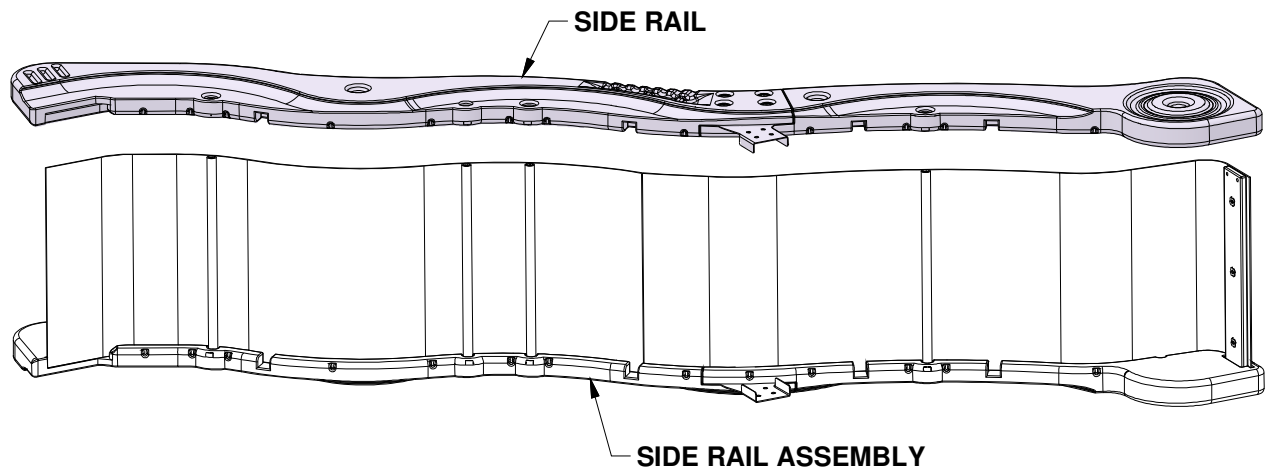

TIP:
USE A RUBBER Mallet TO FULLY SEAT THE SLIDE BED INTO THE SLIDE CAVITY.

STEP 5 - SLIDE ASSEMBLY

QTY	PART NUMBER	DESCRIPTION
4	H100009	BOLT WH 5/16x1 1/4

NOTE:
USE 1 1/4" BOLTS TO FASTEN EACH
SIDE OF THE SLIDE SUPPORT TUBES.

TIP:
HAVING A HELPER HOLD THE SLIDE
ASSEMBLY TOGETHER WHILE YOU FASTEN
WILL MAKE IT EASIER TO ASSEMBLE.

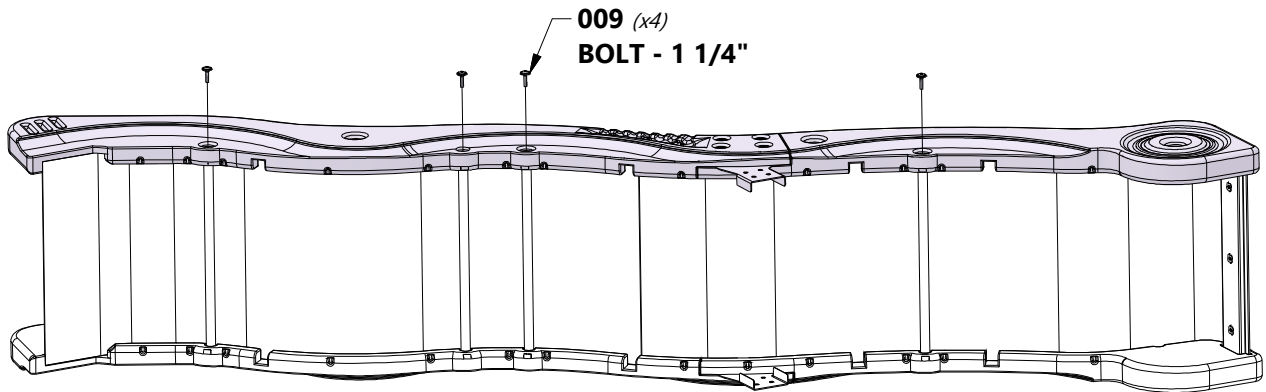

STEP 6 - SLIDE ASSEMBLY

QTY	PART NUMBER	DESCRIPTION
30	H100090	SCREW PFH 8x2 1/2

NOTE:
USING AN 1/8" DRILL BIT, DRILL PILOT HOLES IN EACH INDENTATION ALONG EACH SIDE RAIL. THERE SHOULD BE 15 INDENTATIONS ON EACH RAIL. BE SURE TO DRILL THROUGH THE SLIDE RAIL AND THE SLIDE BED. THEN SECURE WITH THE PROVIDED HARDWARE.

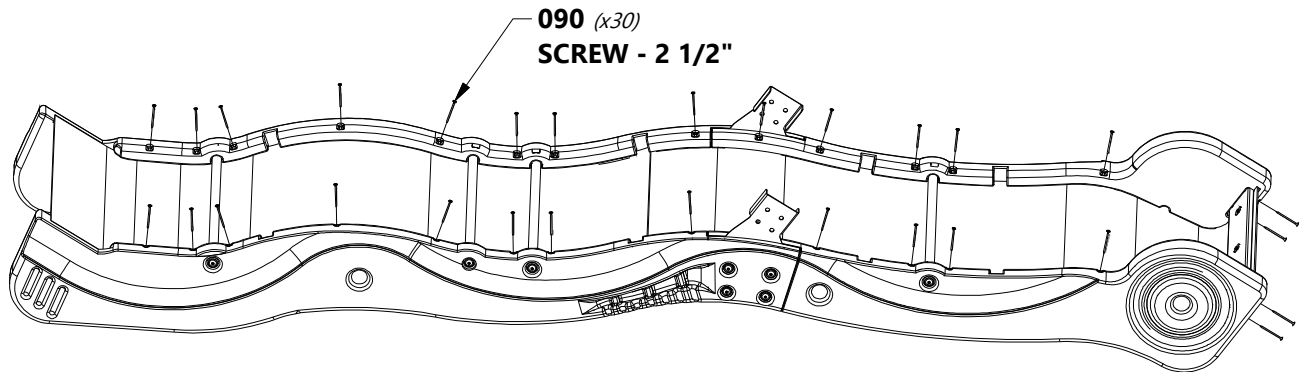

STEP 7 - SLIDE ASSEMBLY

QTY	PART NUMBER	DESCRIPTION
8	H100008	BOLT WH 5/16x1
8	H100074	T-NUT 5/16
4	H100111	SCREW PFH 8x2



H80 | SLIDE BRACE WIDE - W4L15715
(x1) | 1"x3 3/8"x18 3/8" (24x86x466)



H81 | SLIDE BRACE UPRIGHT - W4L13301
(x2) | 1"x3 3/8"x22 7/8" (24x86x580)

TIP:
INSTALL T-NUTS IN WOOD FIRST

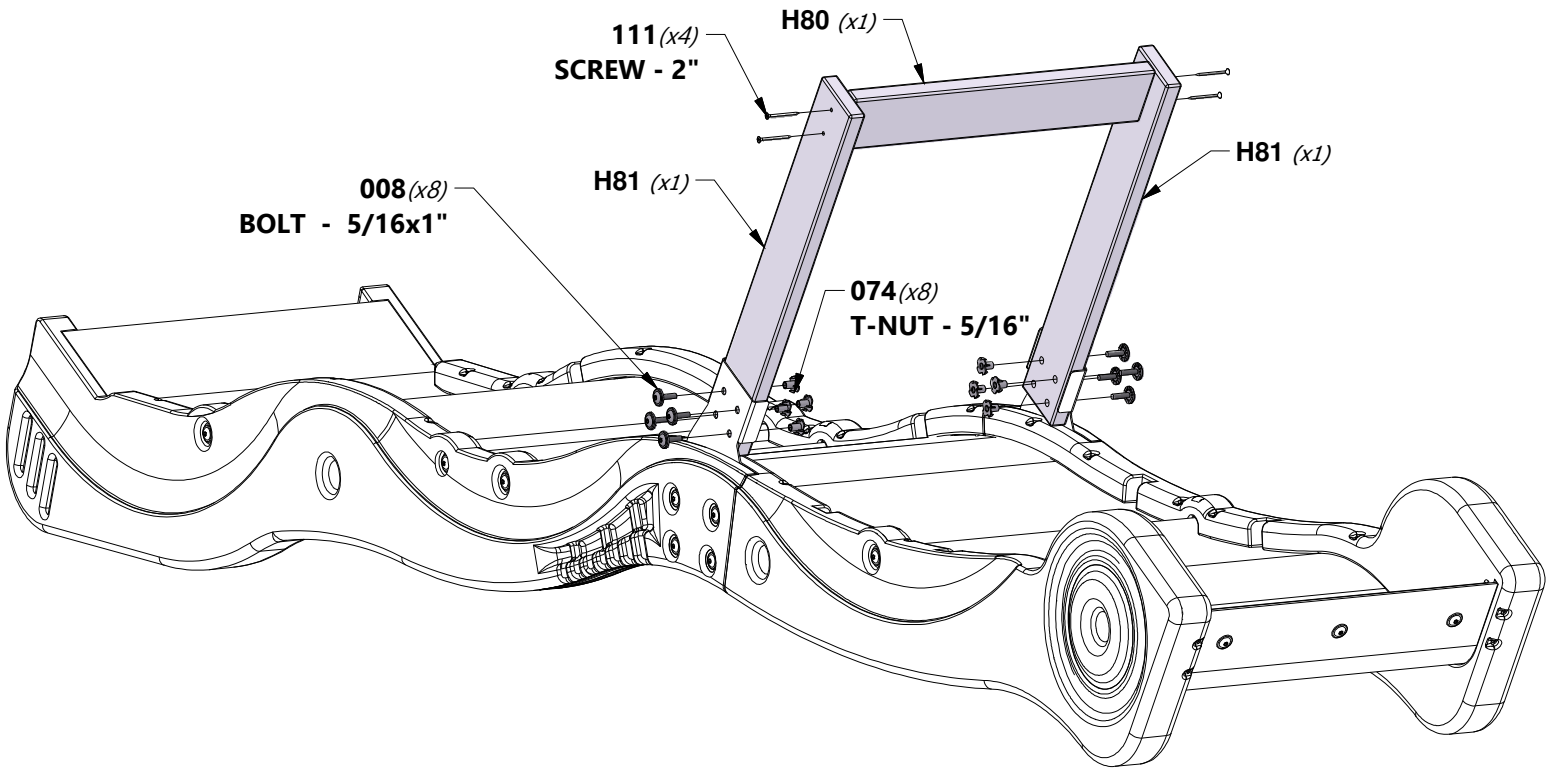

STEP 1 - FORT ASSEMBLY

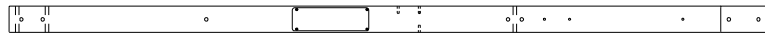

B01 POST - W2A03427
(x1) 3"x3"x86 7/8" (76x76x2206)

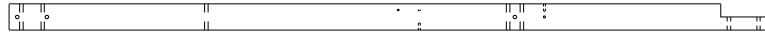

B02 POST - W4L16594
(x1) 3"x3"x86 7/8" (76x76x2206)



G01 GROUND BOARD - W4L16595
(x1) 1"x5 1/4"x89 1/2" (24x134x2274)

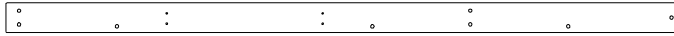

H01 FLOOR SUPPORT - W4L16597
(x1) 1"x3 3/8"x77" (24x86x1956)

QTY	PART NUMBER	DESCRIPTION
10	H100198	WASHER LOCK EXT 8x19 BLK
10	H100379	T-NUT 5/16 BLK
10	H100415	BOLT WH 5/16x3 3/4 BLK

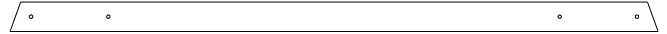

H02 SAFETY BOARD - W4L16600
(x1) 1"x3 3/8"x74 1/4" (24x86x1887)

TIP:
INSTALL T-NUTS IN WOOD FIRST

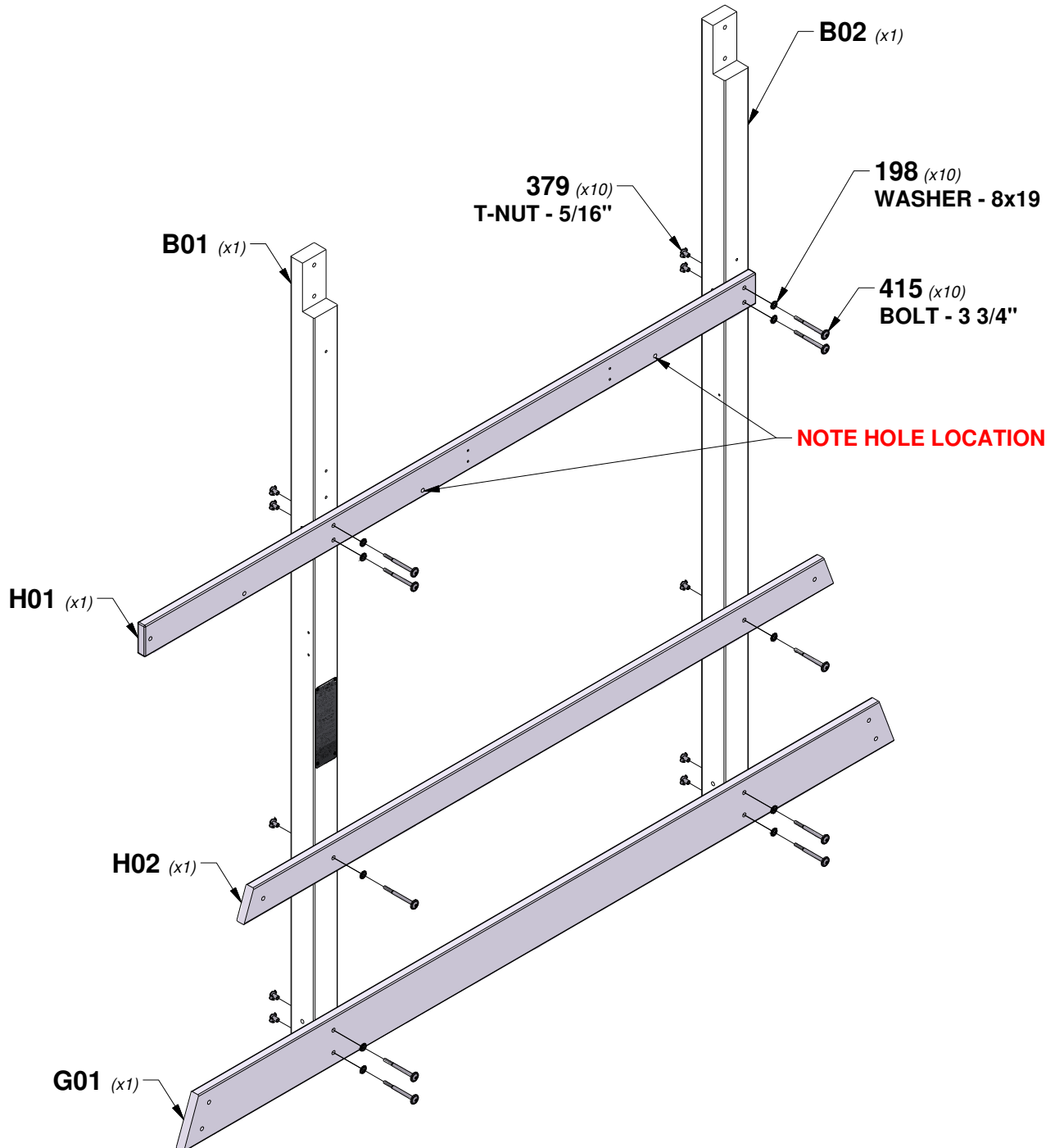

STEP 2 - FORT ASSEMBLY

QTY	PART NUMBER	DESCRIPTION
9	H100198	WASHER LOCK EXT 8x19 BLK
9	H100205	BOLT WH 5/16x2-1/4 BLK
9	H100379	T-NUT 5/16 BLK
5	H100405	WASHER LOCK EXT 6x15 BLK
5	H100487	LAG SCREW WH 1/4x2 BLK

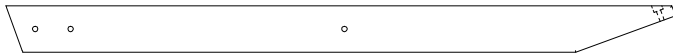

E01 ANGLE BRACE - W4L16596
(x2) 1 3/8"x3 3/8"x48 7/8" (36x86x1241)



E02 DECK BRACE - W4L16598
(x3) 1 3/8"x3 3/8"x17" (36x86x433)

TIP:
INSTALL T-NUTS IN WOOD FIRST.
BE SURE TO SQUARE SUBASSEMBLY.

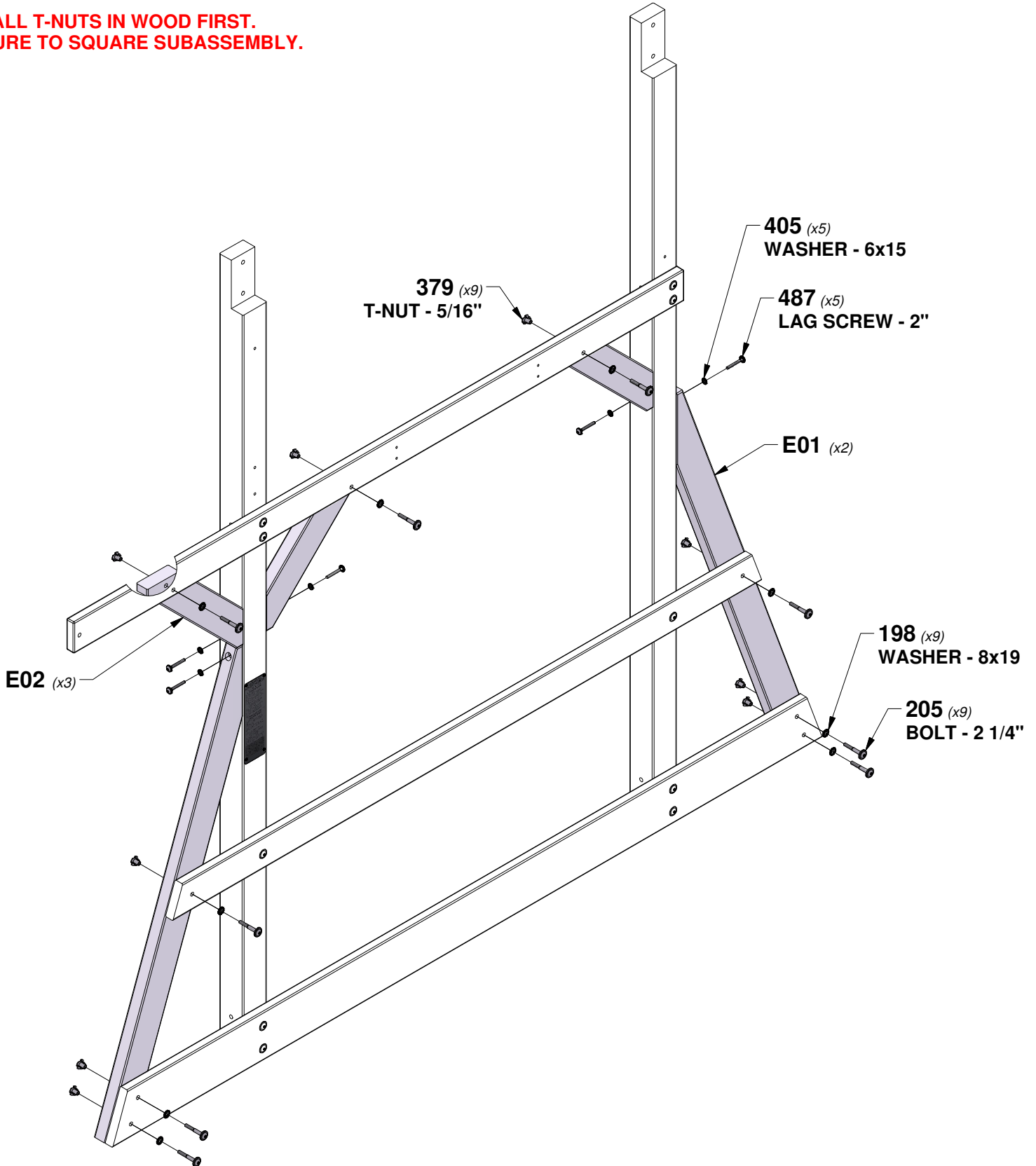

STEP 3 - FORT ASSEMBLY



B03 POST - W4L16603
(x1) 3"x3"x86 7/8" (76x76x2206)

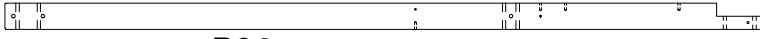

B04 POST - W4L16604
(x1) 3"x3"x86 7/8" (76x76x2206)

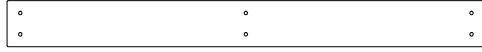

G03 GROUND BOARD - W4L16606
(x1) 1"x5 1/4"x54 3/4" (24x134x1390)

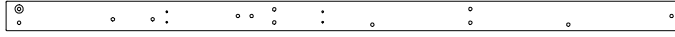

H03 FLOOR SUPPORT - W4L16601
(x1) 1"x3 3/8"x77" (24x86x1956)

QTY	PART NUMBER	DESCRIPTION
10	H100198	WASHER LOCK EXT 8x19 BLK
2	H100205	BOLT WH 5/16x2-1/4 BLK
10	H100379	T-NUT 5/16 BLK
2	H100405	WASHER LOCK EXT 6x15 BLK
7	H100415	BOLT WH 5/16x3 3/4 BLK
2	H100487	LAG SCREW WH 1/4x2 BLK
1	H100503	BOLT WH 5/16x3-1/2 BLK



E02 DECK BRACE - W4L16598
(x2) 1 3/8"x3 3/8"x17" (36x86x433)

TIP:
INSTALL T-NUTS IN WOOD FIRST

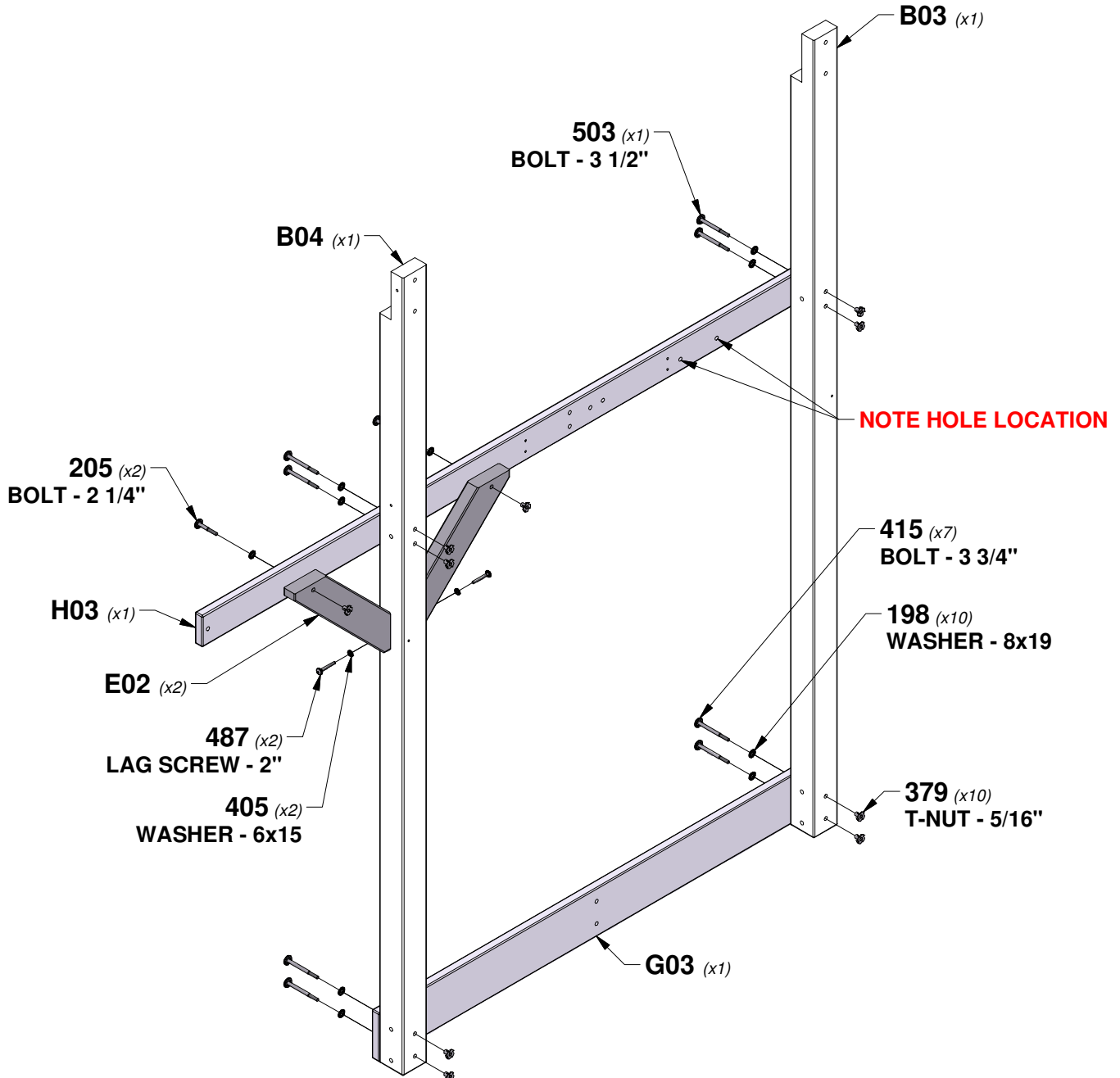

STEP 4 - FORT ASSEMBLY



G02 GROUND BOARD - W4L16605
(x2) 1"x5 1/4"x53 3/4" (24x134x1364)



H05 FLOOR RAIL - W4L16608
(x1) 1"x3 3/8"x52 3/4" (24x86x1340)



H07 FLOOR SUPPORT - W4L16624
(x2) 1"x3"x2 1/8" (24x76x54)

QTY	PART NUMBER	DESCRIPTION
10	H100198	WASHER LOCK EXT 8x19 BLK
10	H100379	T-NUT 5/16 BLK
8	H100415	BOLT WH 5/16x3 3/4 BLK
2	H100480	BOLT WH 5/16x4 3/4 BLK

TIP:
INSTALL T-NUTS IN WOOD FIRST

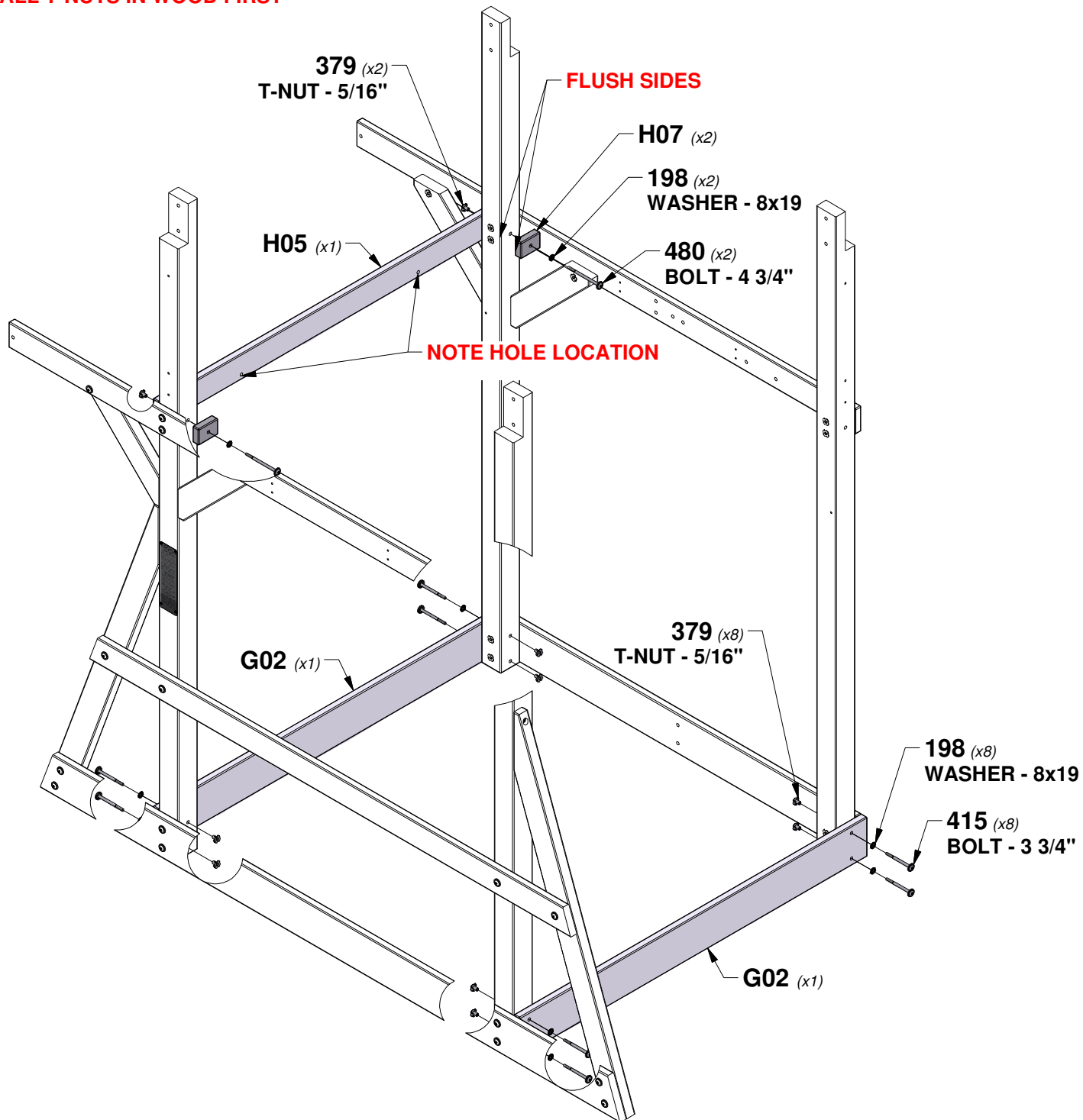

STEP 5 - FORT ASSEMBLY



H04 FLOOR RAIL - W4L16607
(x1) 1"x3 3/8"x53 3/4" (24x86x1364)

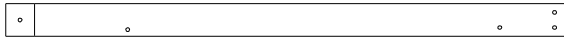

H08 FLOOR RAIL - W4L16628
(x1) 1"x3 3/8"x58 3/8" (24x86x1483)



H07 FLOOR SUPPORT - W4L16624
(x2) 1"x3"x2 1/8" (24x76x54)

QTY	PART NUMBER	DESCRIPTION
2	H100198	WASHER LOCK EXT 8x19 BLK
2	H100379	T-NUT 5/16 BLK
2	H100480	BOLT WH 5/16x4 3/4 BLK

TIP:
INSTALL T-NUTS IN WOOD FIRST

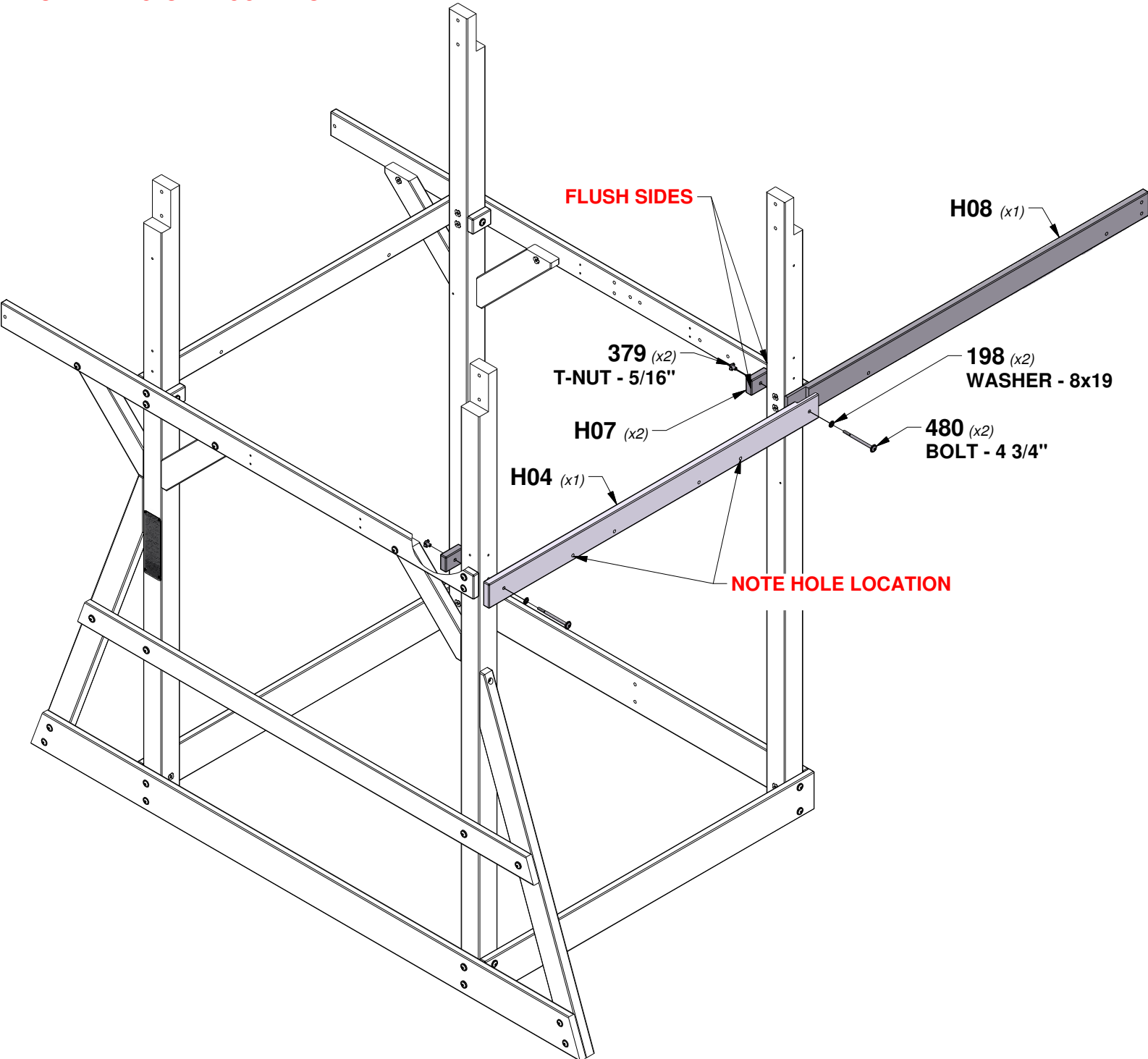

STEP 6 - FORT ASSEMBLY



E02 DECK BRACE - W4L16598
(x5) 1 3/8"x3 3/8"x17" (36x86x433)

QTY	PART NUMBER	DESCRIPTION
5	H100198	WASHER LOCK EXT 8x19 BLK
5	H100205	BOLT WH 5/16x2-1/4 BLK
5	H100379	T-NUT 5/16 BLK
5	H100405	WASHER LOCK EXT 6x15 BLK
5	H100487	LAG SCREW WH 1/4x2 BLK

TIP:
INSTALL T-NUTS IN WOOD FIRST

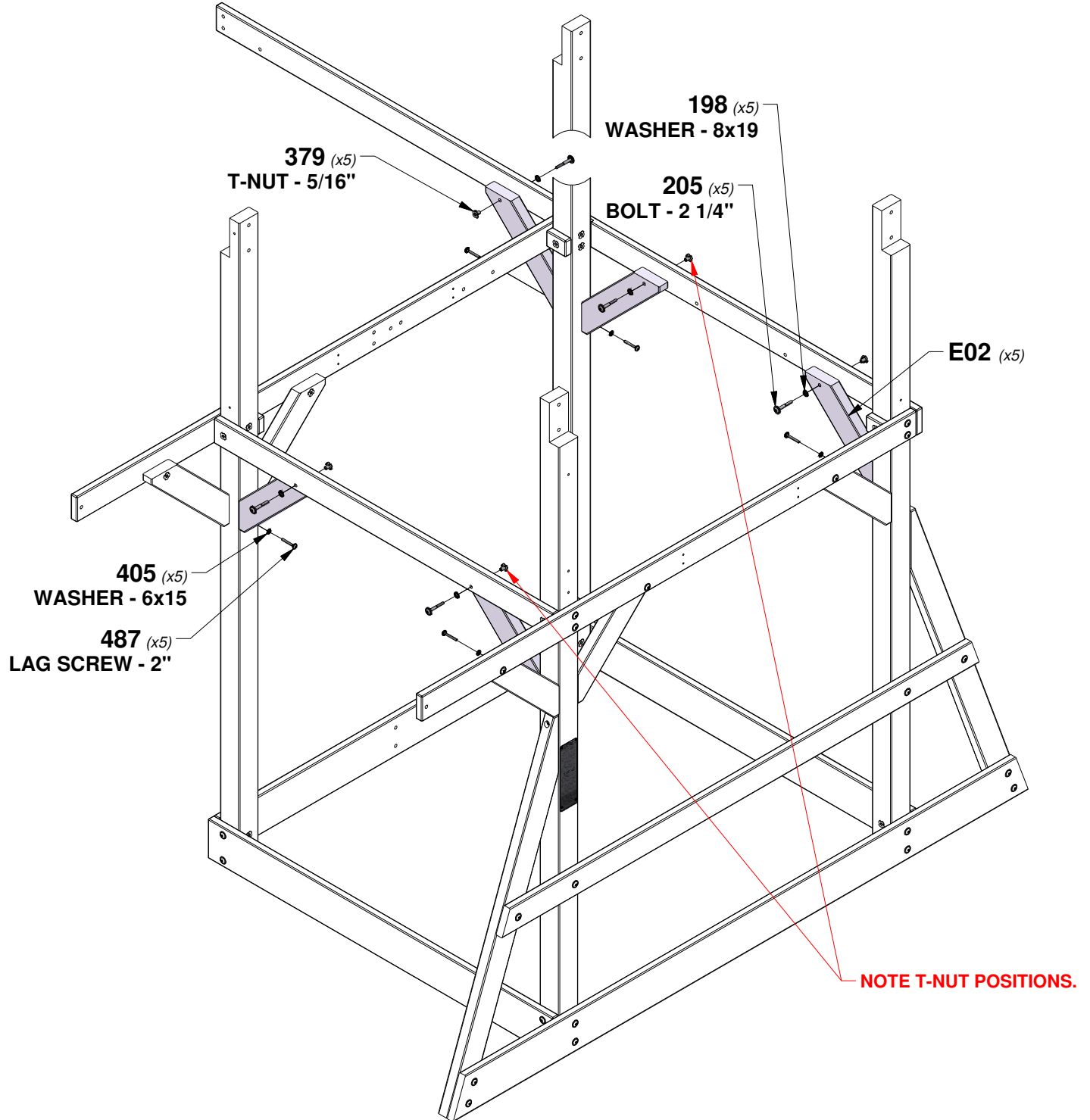

STEP 7 - FORT ASSEMBLY

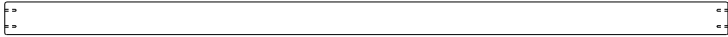

F01 FLOOR JOIST - W4L16610
(x2) 1 3/8"x2 3/8"x52 3/4" (36x60x1340)

QTY	PART NUMBER	DESCRIPTION
8	H100092	SCREW PFH 8x3

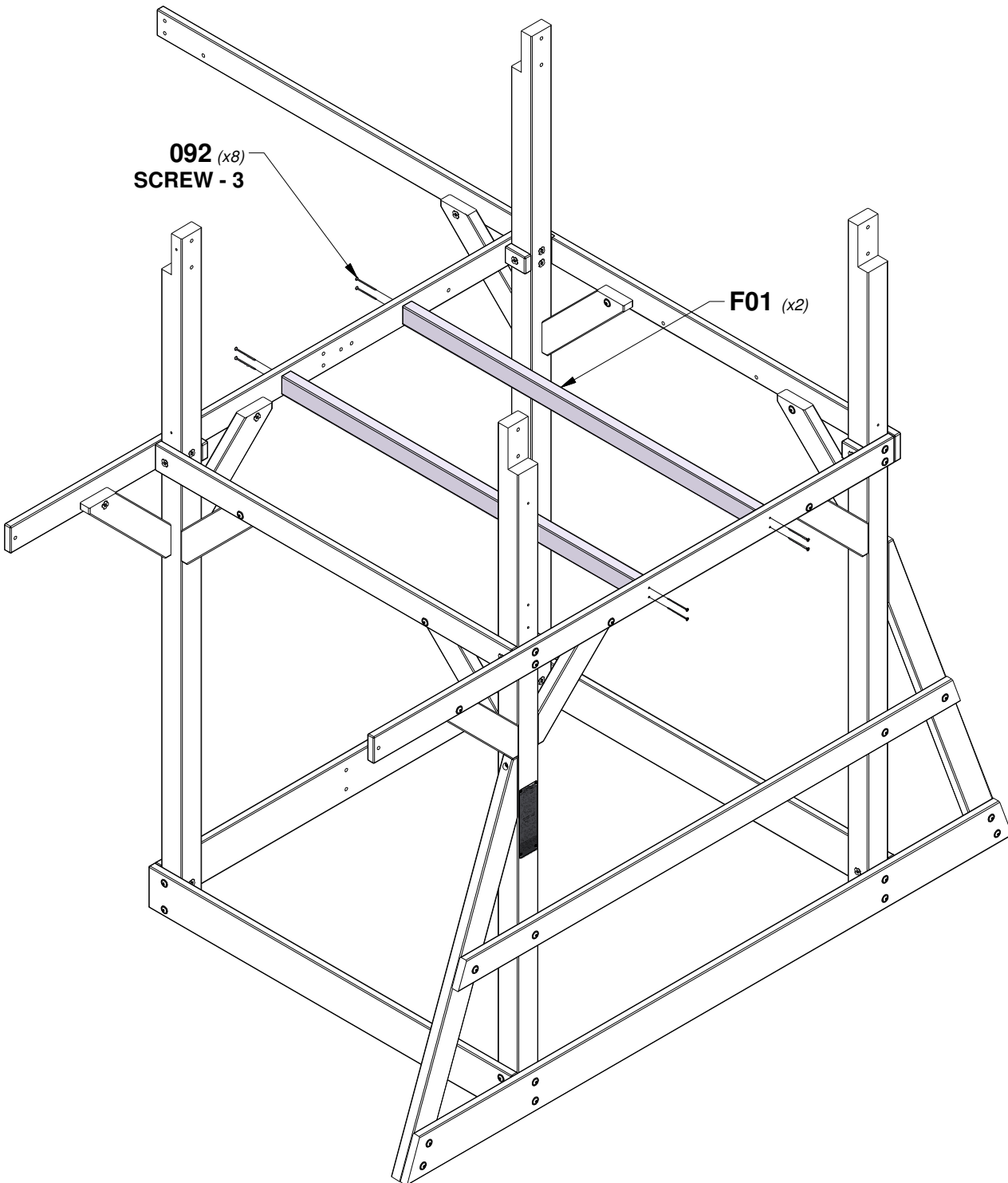
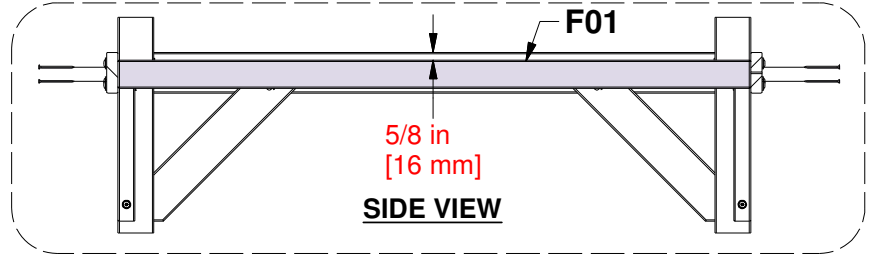

STEP 8 - FORT ASSEMBLY

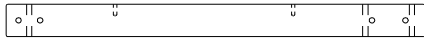

F02 UPRIGHT - W4L16611
(x1) 1 3/8"x2 3/8"x30 1/2" (36x60x776)



F03 UPRIGHT - W4L16612
(x1) 1 3/8"x2 3/8"x30 1/2" (36x60x776)

QTY	PART NUMBER	DESCRIPTION
6	H100198	WASHER LOCK EXT 8x19 BLK
4	H100205	BOLT WH 5/16x2-1/4 BLK
6	H100379	T-NUT 5/16 BLK
2	H100484	BOLT WH 5/16x3 1/4 BLK



H06 FLOOR RAIL - W4L16614
(x1) 1"x3 3/8"x54 5/8" (24x86x1388)

TIP:
INSTALL T-NUTS IN WOOD FIRST

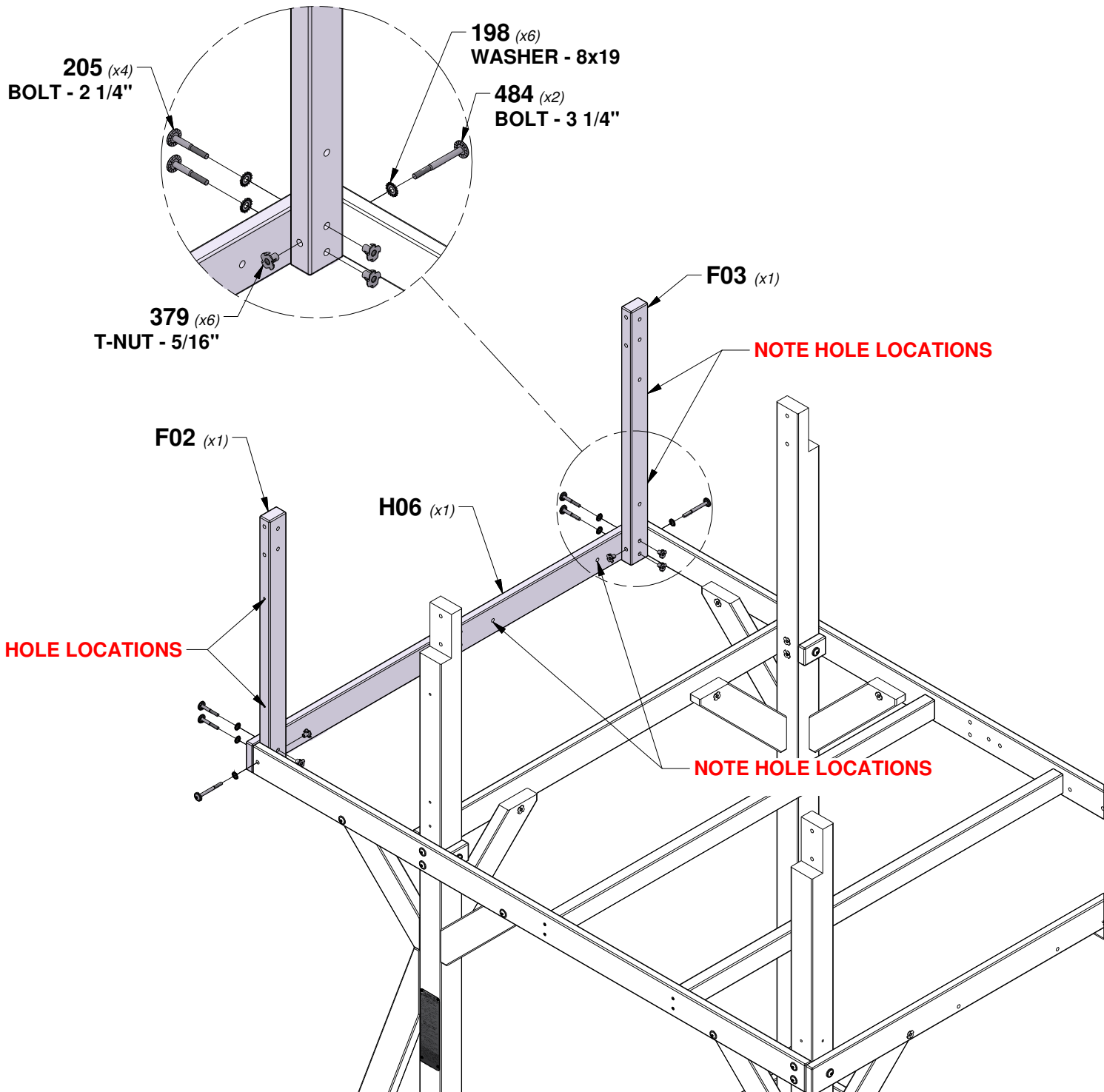

STEP 9A - FORT ASSEMBLY

QTY	PART NUMBER	DESCRIPTION
4	H100198	WASHER LOCK EXT 8x19 BLK
4	H100205	BOLT WH 5/16x2-1/4 BLK
4	H100379	T-NUT 5/16 BLK



E03 UPRIGHT - W4L16627
(x1) 1 3/8"x3 3/8"x59 5/8" (36x86x1516)

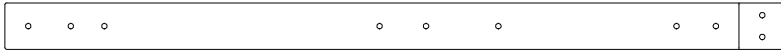

E04 UPRIGHT - W4L16638
(x1) 1 3/8"x3 3/8"x56 7/8" (36x86x1446)

TIP:
INSTALL T-NUTS IN WOOD FIRST

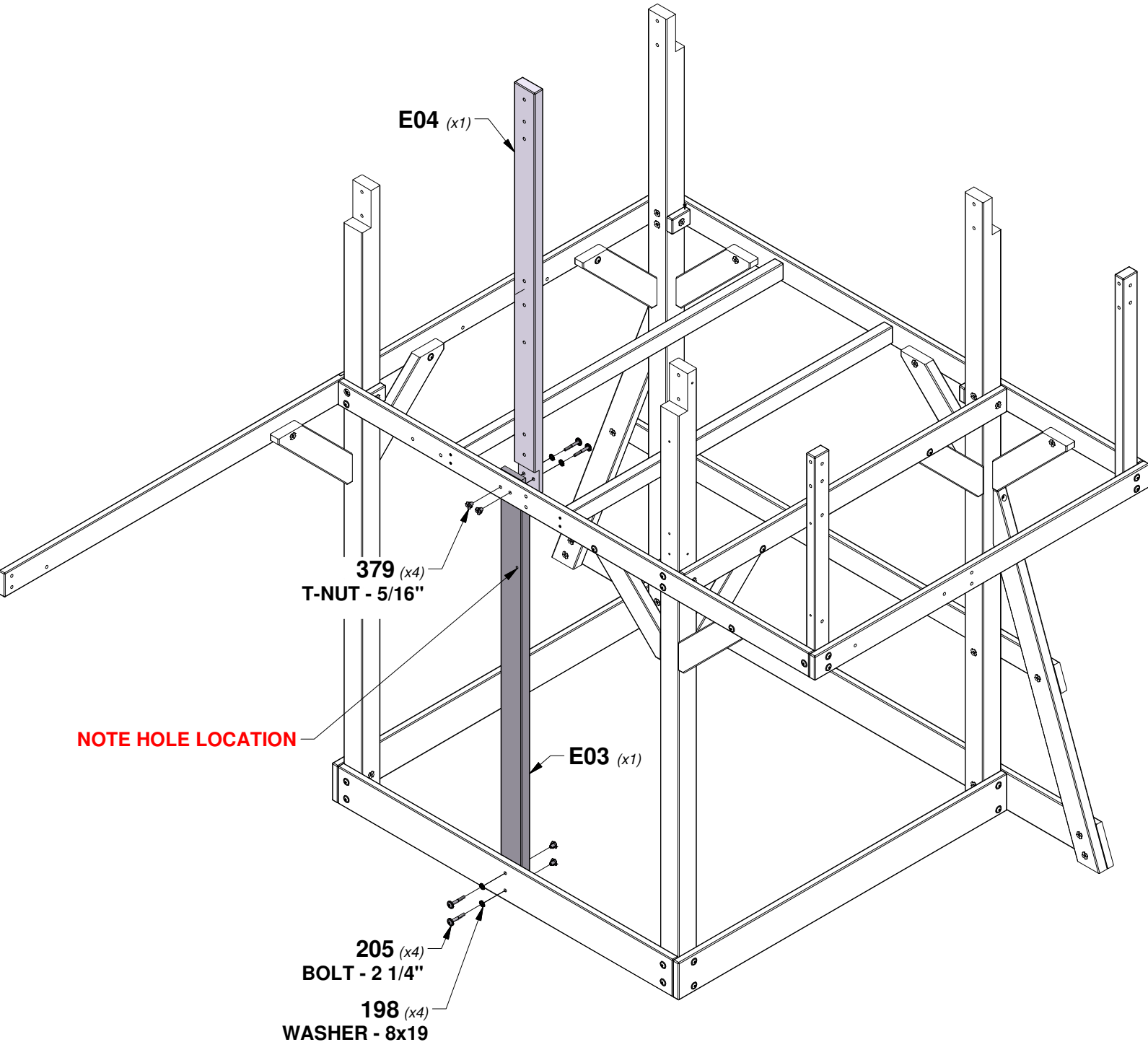

STEP 9B - FORT ASSEMBLY

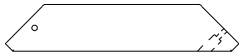

E02 DECK BRACE - W4L16598
(x1) 1 3/8"x3 3/8"x17" (36x86x433)



A4M00855 L BRACKET
(x1) 51x32x82x3.175



H09 FLOOR RAIL - W4L16629
(x1) 1"x3 3/8"x54 1/2" (24x86x1383)

6 7/8 in [175 mm]

QTY	PART NUMBER	DESCRIPTION
1	H100198	WASHER LOCK EXT 8x19 BLK
1	H100205	BOLT WH 5/16x2-1/4 BLK
5	H100379	T-NUT 5/16 BLK
1	H100398	T-NUT 1/4 BLK
1	H100405	WASHER LOCK EXT 6x15 BLK
4	H100468	BOLT WH 5/16x1 BLK
1	H100567	BOLT WH 1/4x2-1/4 BLK

TIP:
INSTALL T-NUTS IN WOOD FIRST

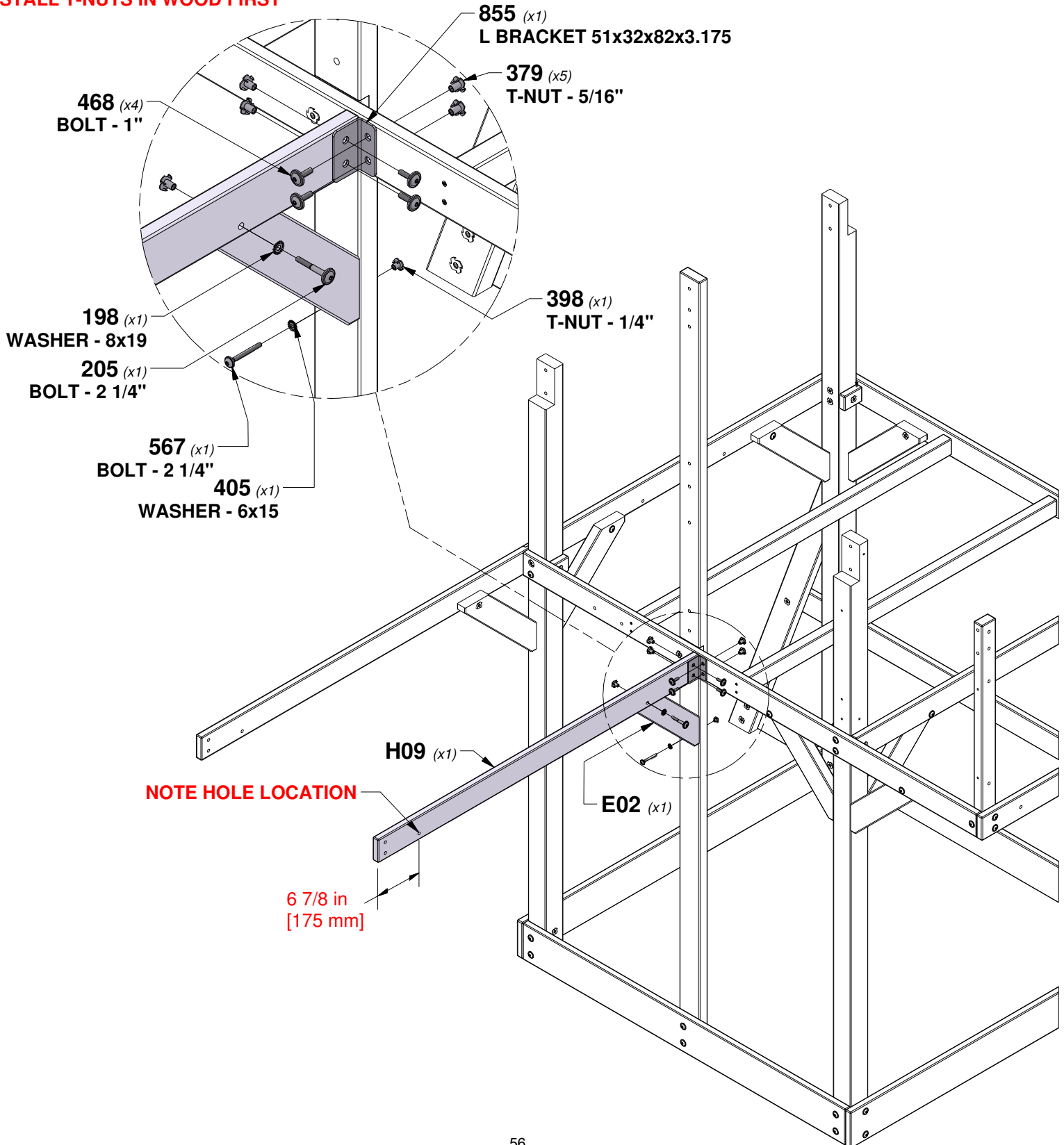

STEP 10 - FORT ASSEMBLY



F05 UPRIGHT - W4L16630
 (x2) 1 3/8"x2 3/8"x30 1/2" (36x60x776)

TOP



H10 FLOOR RAIL - W4L16632
 (x1) 1"x3 3/8"x31" (24x86x786)



H11 FLOOR SUPPORT - W4L16648
 (x2) 1"x2 3/4"x2 3/8" (24x60x70)

QTY	PART NUMBER	DESCRIPTION
6	H100198	WASHER LOCK EXT 8x19 BLK
2	H100205	BOLT WH 5/16x2-1/4 BLK
6	H100379	T-NUT 5/16 BLK
4	H100484	BOLT WH 5/16x3 1/4 BLK

TIP:
INSTALL T-NUTS IN WOOD FIRST

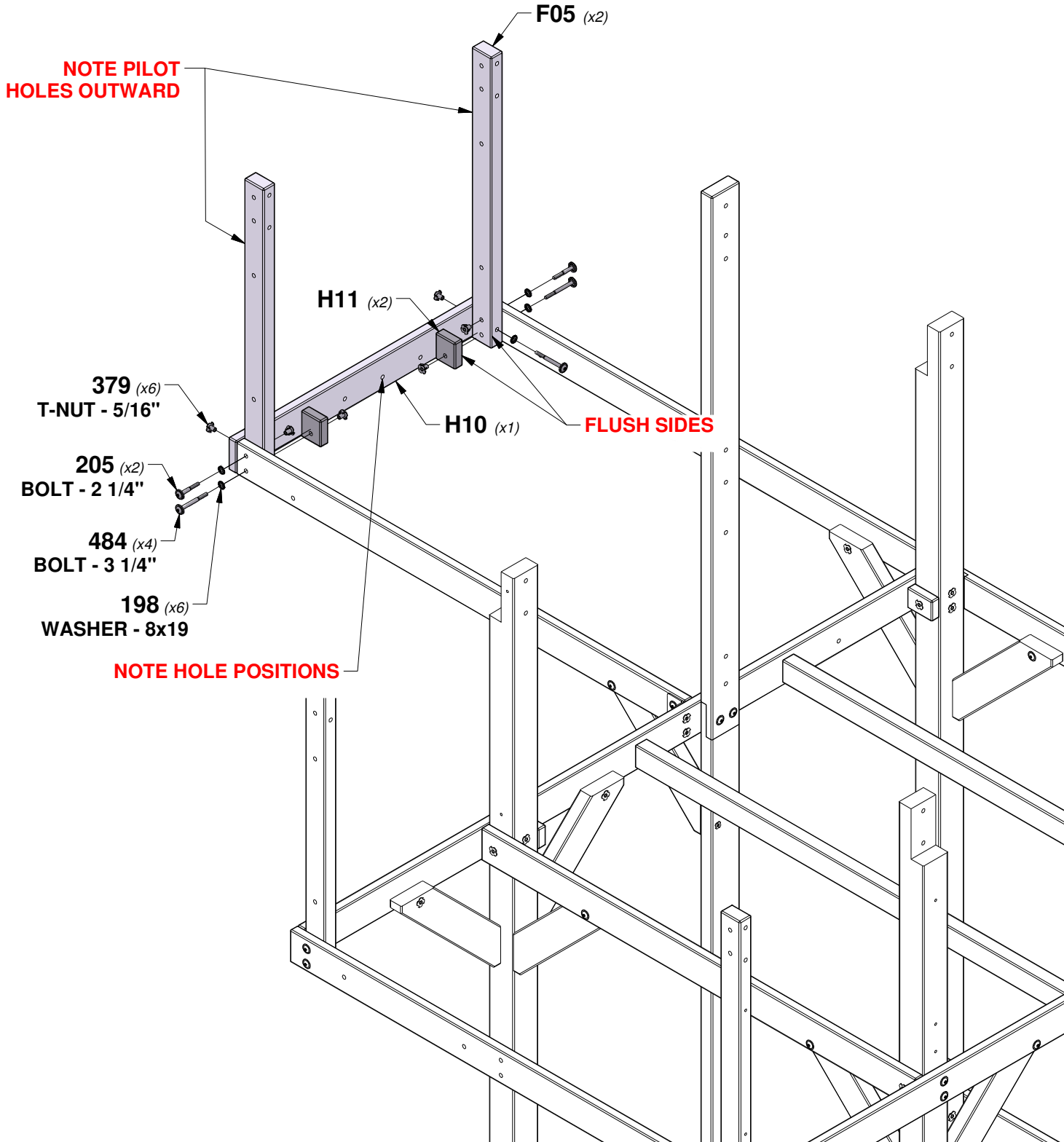

STEP 11 - FORT ASSEMBLY

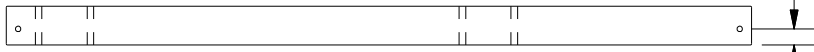

B09 SWING SUPPORT - W4L16651
(x1) 2 7/8"x3"x54 3/8" (72x76x1381)

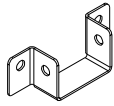

A4M01878 JOIST HANGER
(x2) 90°



A4M00505 SWING HANGER
(x2)

1 1/8 in
[30 mm]
DOWN

QTY	PART NUMBER	DESCRIPTION
4	H100073	T-NUT 3/8
4	H100102	WASHER FLAT 11x25
4	H100107	WASHER LOCK INT 10x18
2	H100192	NUT BARREL WH 5/16x7/8 BLK
2	H100195	BOLT WH 5/16x2-3/4 BLK
4	H100379	T-NUT 5/16 BLK
4	H100434	BOLT HEX 3/8x3 1/4
4	H100468	BOLT WH 5/16x1 BLK

TIP:
INSTALL T-NUTS IN WOOD FIRST

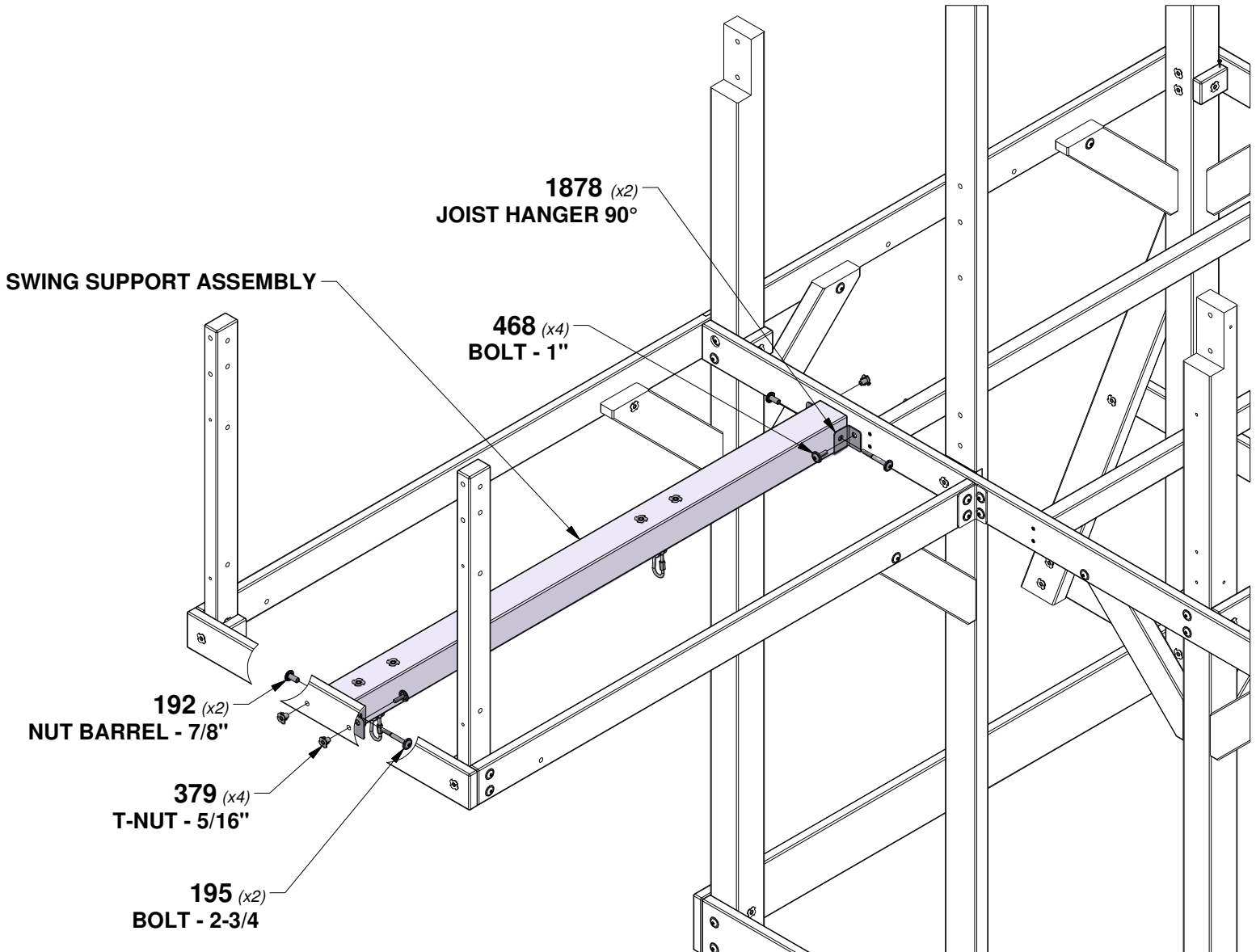
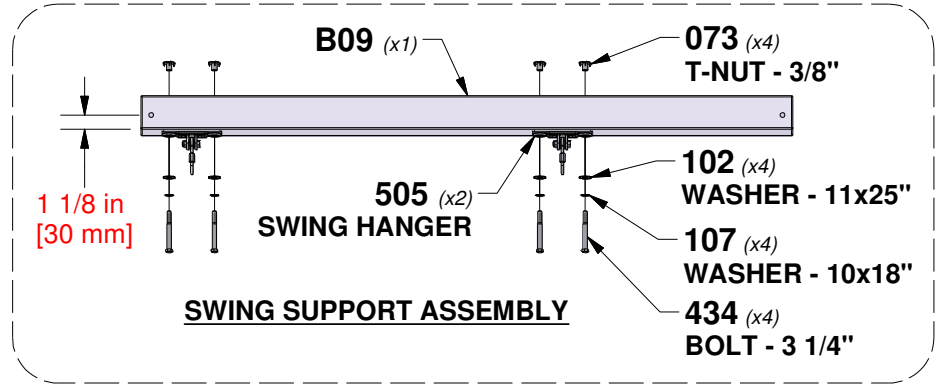

STEP 12 - FORT ASSEMBLY

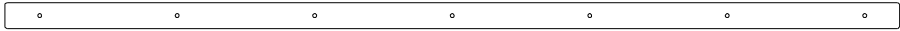

T01 SUPPORT BOARD - W4L16599
 (x2) 1"x1 3/8"x46 5/8" (24x34x1184)

QTY	PART NUMBER	DESCRIPTION
14	H100089	SCREW PFH 8x1-3/4"

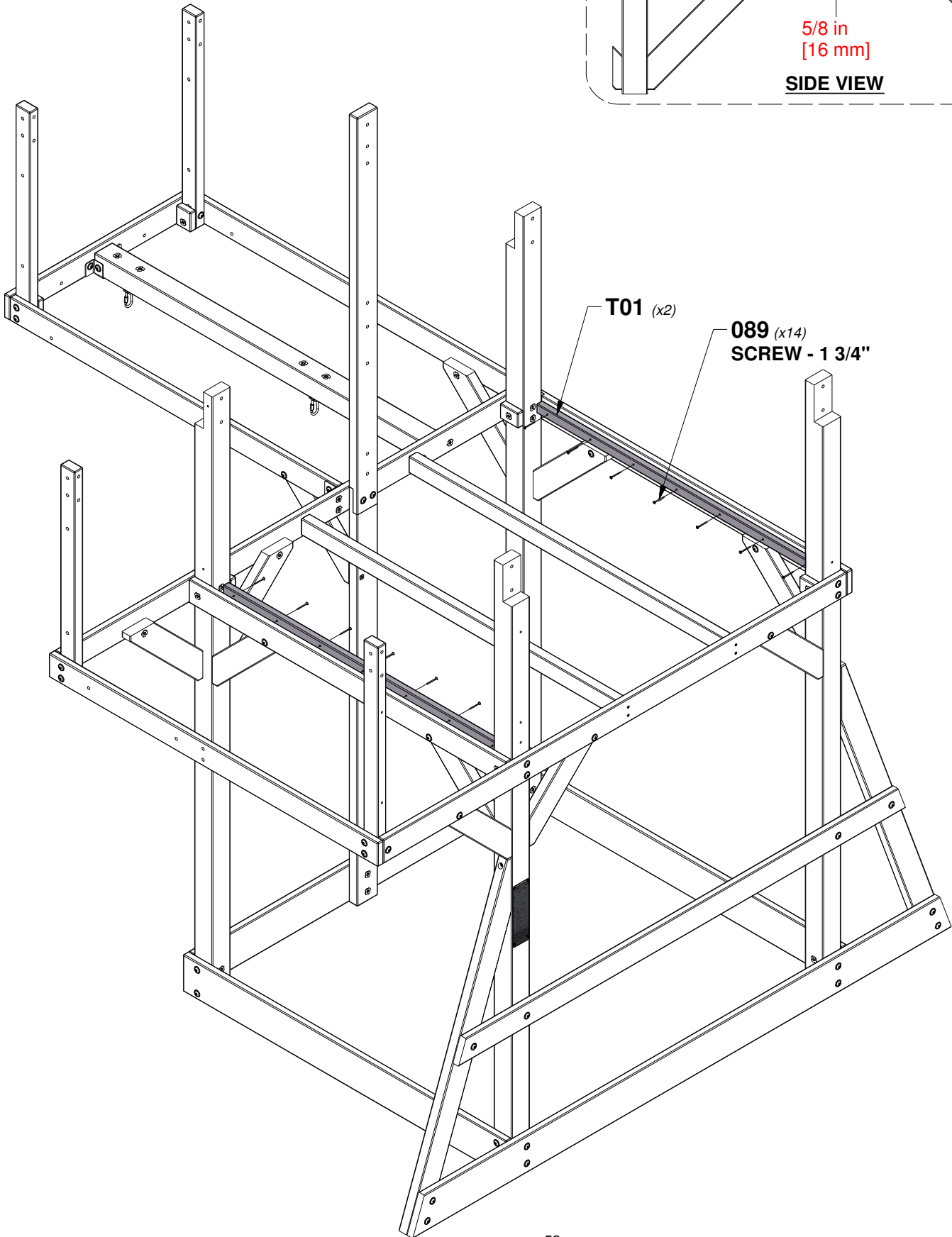
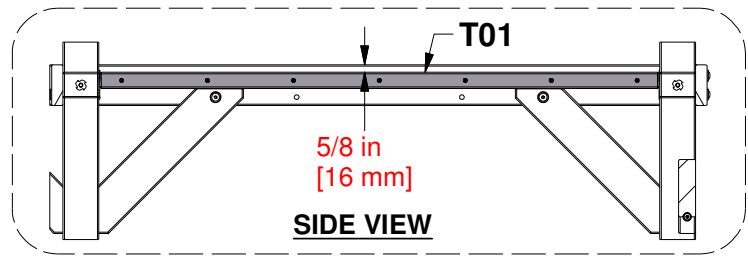

STEP 13 - FORT ASSEMBLY



T06 SUPPORT BOARD - W4L19024
(x2) 1"x1 3/8"x51 3/4" (24x34x1314)

QTY	PART NUMBER	DESCRIPTION
16	H100089	SCREW PFH 8x1-3/4"

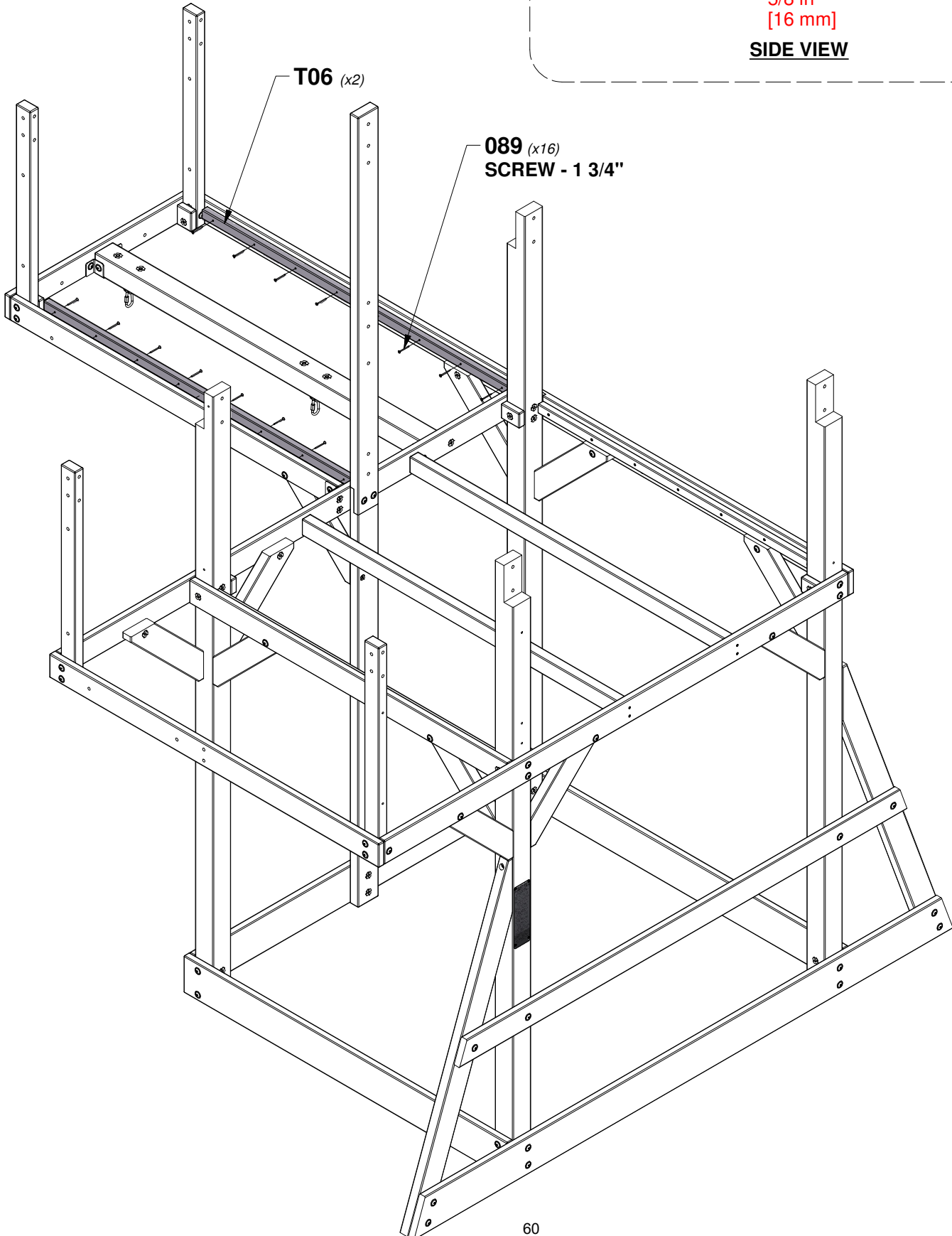
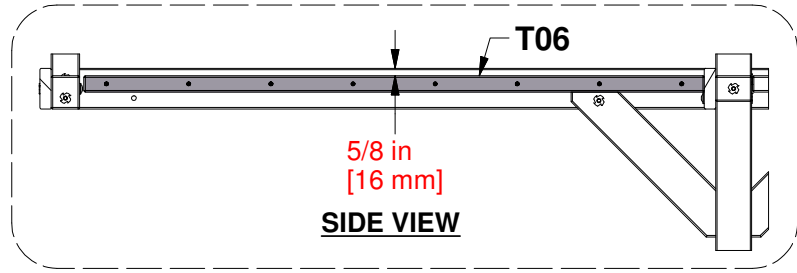

STEP 14 - FORT ASSEMBLY

QTY	PART NUMBER	DESCRIPTION
29	H100089	SCREW PFH 8x1-3/4"
2	H100379	T-NUT 5/16 BLK

T02 SUPPORT BOARD - W4L16609
(x1) 1"x1 3/8"x52 5/8" (24x34x1336)

T03 SUPPORT BOARD - W4L16615
(x1) 1"x1 3/8"x24 3/8" (24x34x619)

T04 SUPPORT BOARD - W4L16616
(x1) 1"x1 3/8"x21" (24x34x533)

T05 SUPPORT BOARD - W4L16626
(x2) 1"x1 3/8"x18 7/8" (24x34x478)

TIP:
INSTALL T-NUTS IN WOOD FIRST.
THEN INSTALL T02 BOARD.
INSTALL T05 BOARDS LAST.

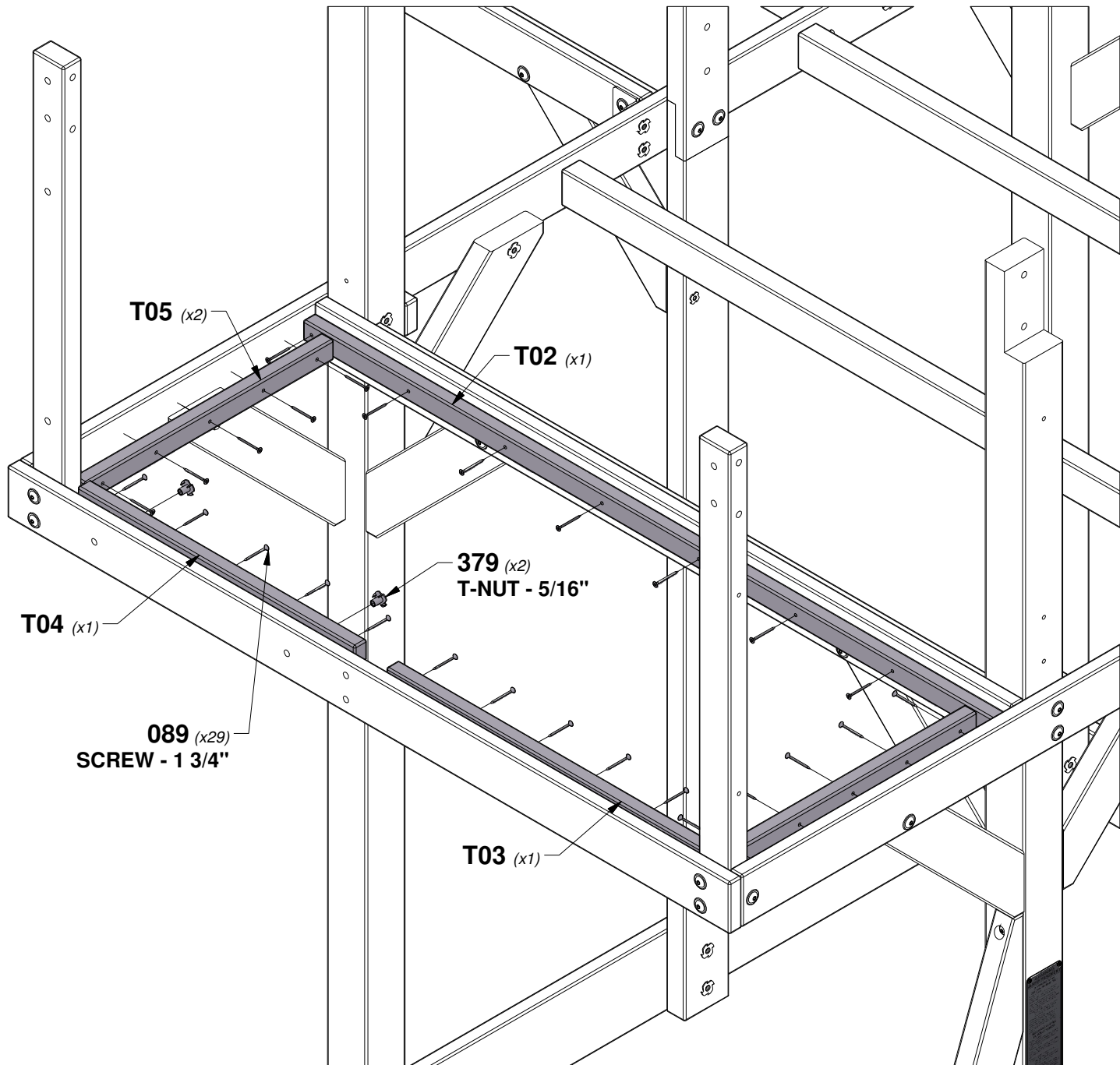
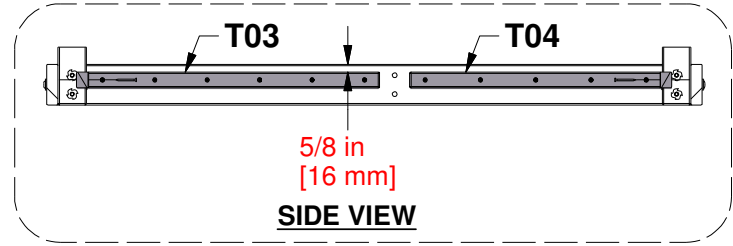

STEP 15 - FORT ASSEMBLY

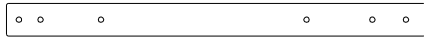

F04 UPRIGHT - W4L16613
 (x1) 1 3/8"x2 3/8"x30 1/2" (36x60x776)



H11 FLOOR SUPPORT - W4L16648
 (x1) 1"x2 3/4"x2 3/8" (24x60x70)

QTY	PART NUMBER	DESCRIPTION
2	H100198	WASHER LOCK EXT 8x19 BLK
1	H100205	BOLT WH 5/16x2-1/4 BLK
2	H100379	T-NUT 5/16 BLK
1	H100484	BOLT WH 5/16x3 1/4 BLK

TIP:
INSTALL T-NUTS IN WOOD FIRST

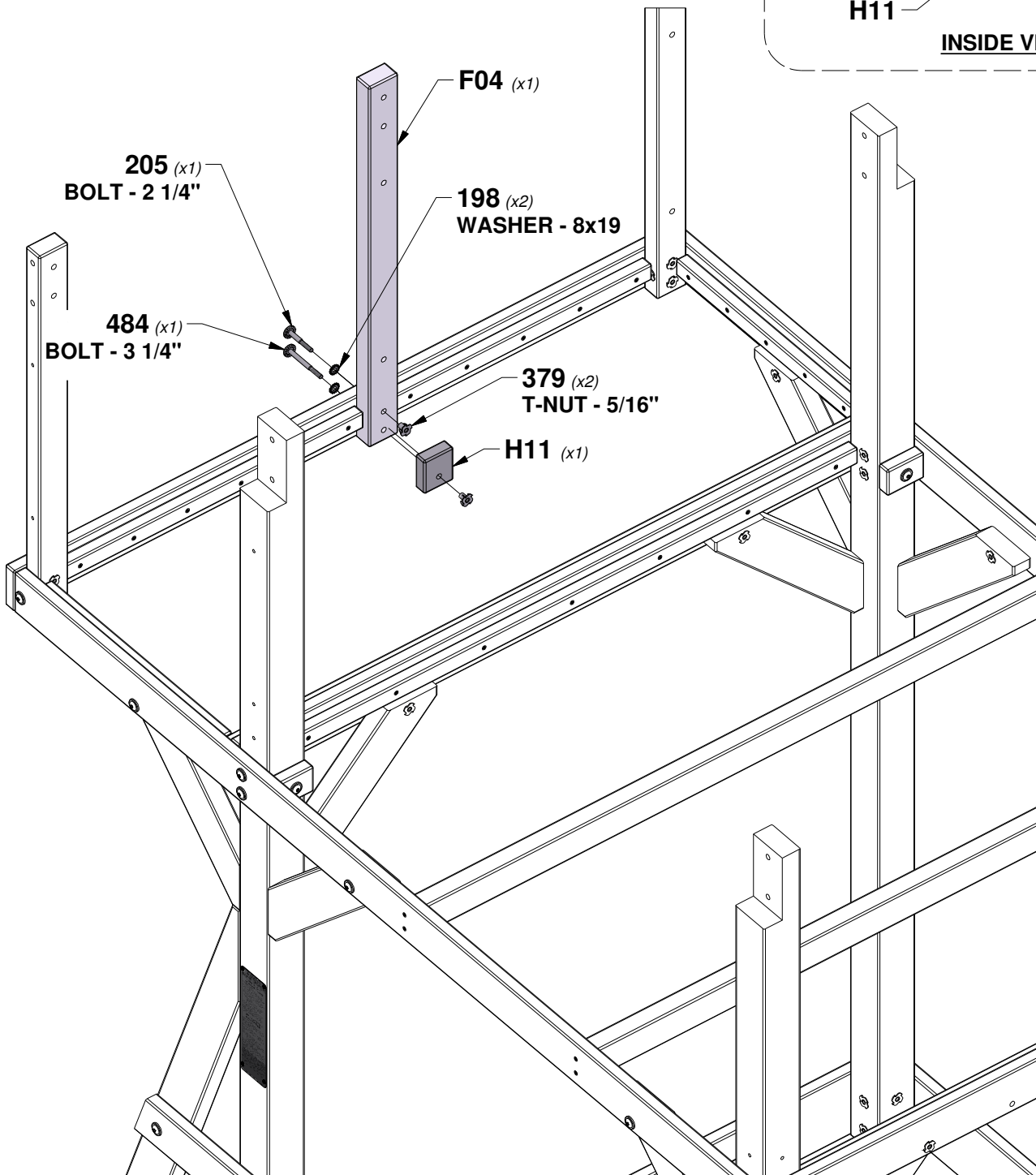
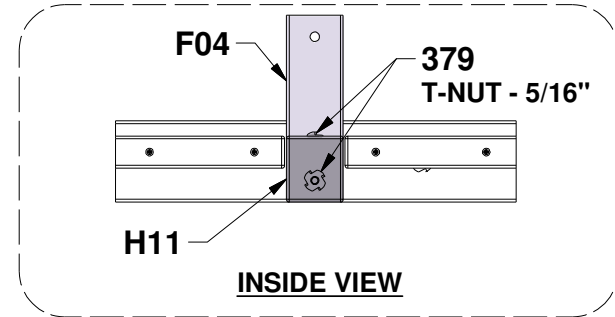

STEP 16 - FORT ASSEMBLY

QTY	PART NUMBER	DESCRIPTION
2	H100198	WASHER LOCK EXT 8x19 BLK
2	H100378	BOLT WH 5/16x1 3/4 BLK

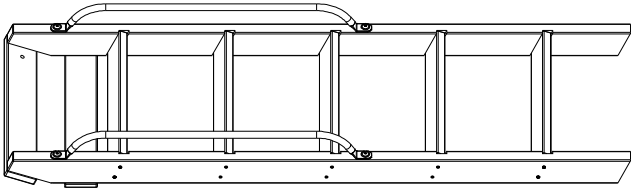

LADDER ASSEMBLY

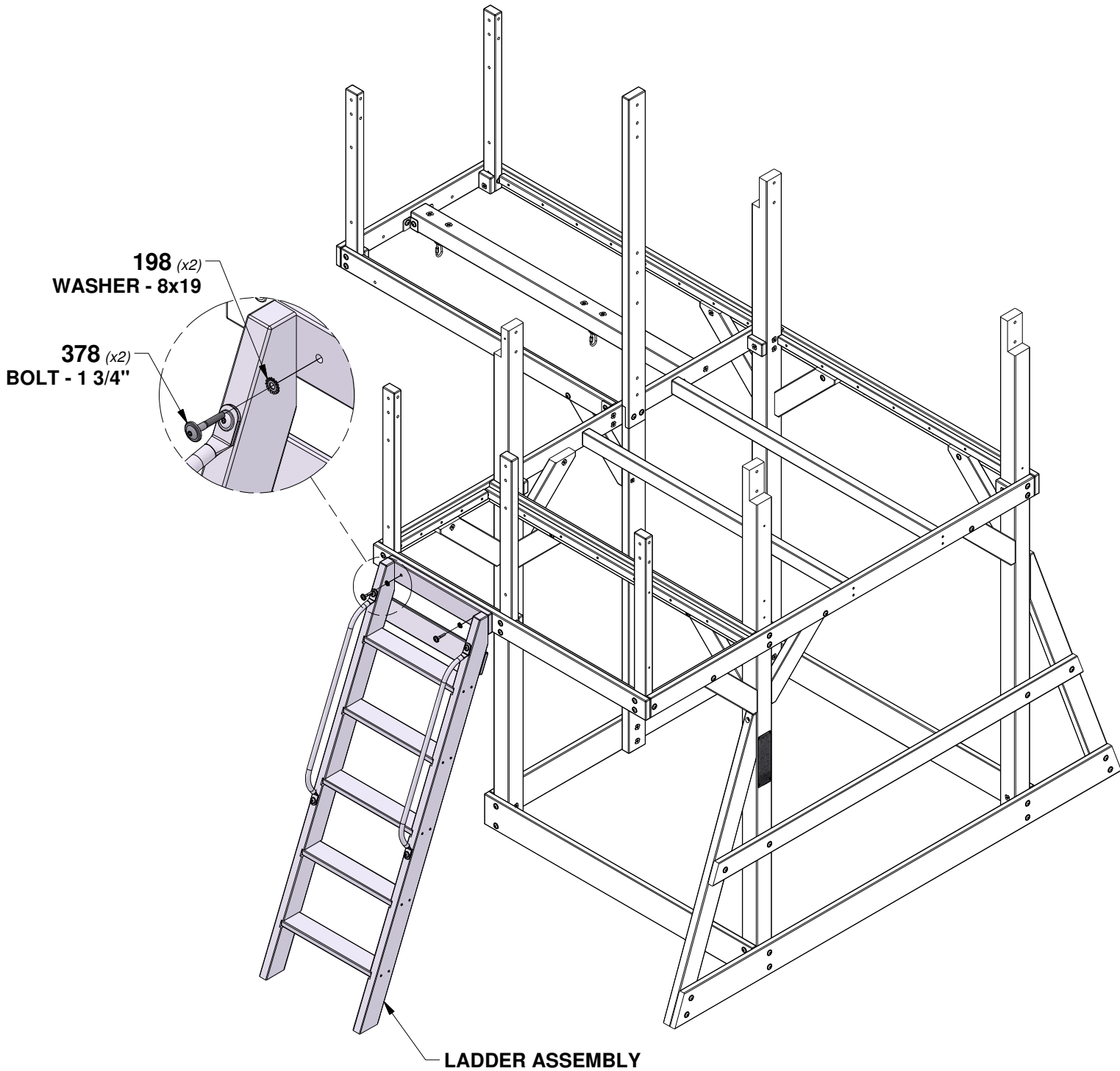

STEP 17 - FORT ASSEMBLY

QTY	PART NUMBER	DESCRIPTION
60	H100086	SCREW PFH 8x1-1/2"



M02 FLOOR BOARD - W4L16642
 (x11) 5/8"x3 3/8"x21 1/4" (16x86x540)

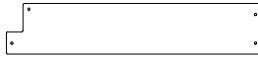

L01 FLOOR BOARD - W4L16644
 (x2) 5/8"x4 1/4"x21 1/4" (16x107x540)



M04 FLOOR BOARD - W4L19022
 (x2) 5/8"x3 3/8"x21 1/4" (16x86x540)

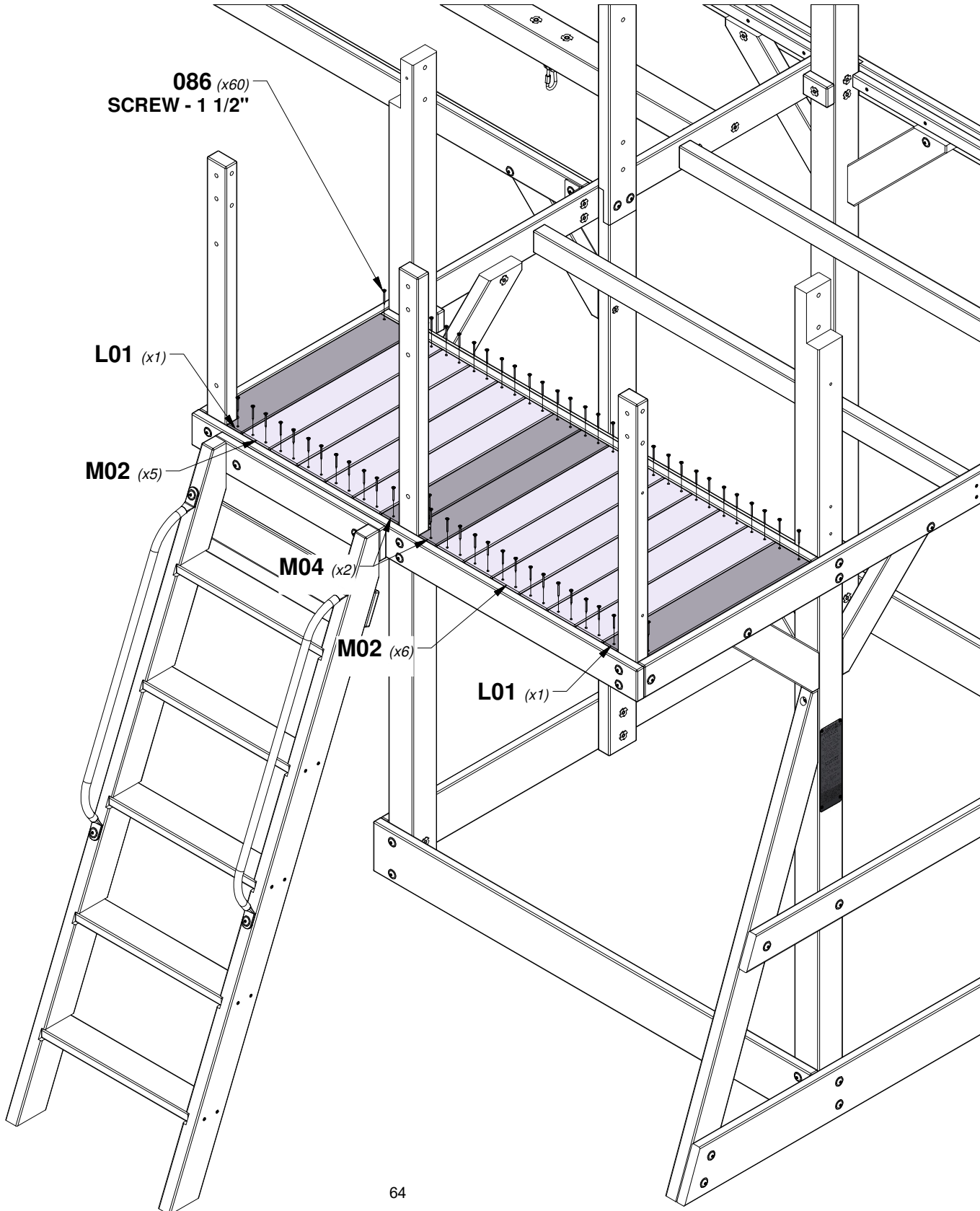

STEP 18 - FORT ASSEMBLY

QTY	PART NUMBER	DESCRIPTION
90	H100086	SCREW PFH 8x1-1/2"

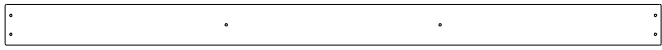

M03 FLOOR BOARD - W4L16643
(x13) 5/8"x3 3/8"x54 5/8" (16x86x1389)



L02 FLOOR BOARD - W4L16645
(x1) 5/8"x4 1/4"x54 5/8" (16x107x1389)

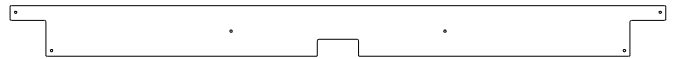

L03 FLOOR BOARD - W4L16646
(x1) 5/8"x4 1/4"x54 5/8" (16x107x1389)

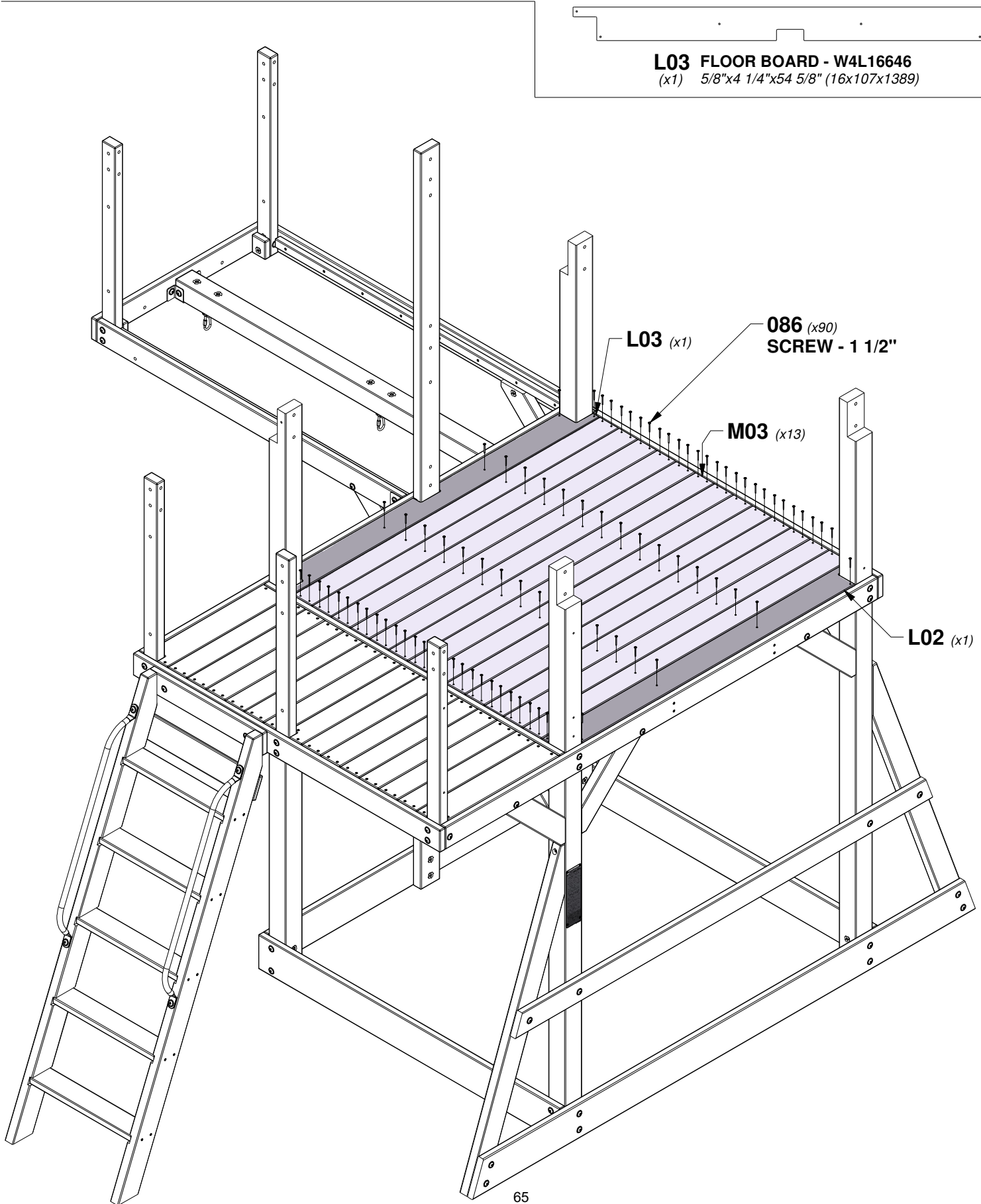

STEP 19 - FORT ASSEMBLY

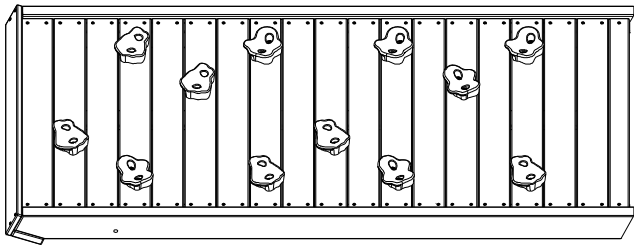

ROCK WALL ASSEMBLY

QTY	PART NUMBER	DESCRIPTION
2	H100195	BOLT WH 5/16x2-3/4 BLK
2	H100198	WASHER LOCK EXT 8x19 BLK
4	H100379	T-NUT 5/16 BLK
2	H100457	BOLT WH 5/16x2 BLK
2	H100468	BOLT WH 5/16x1 BLK

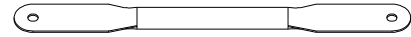

A4M00630 (x2) METAL DECK BRACE 380 C/C

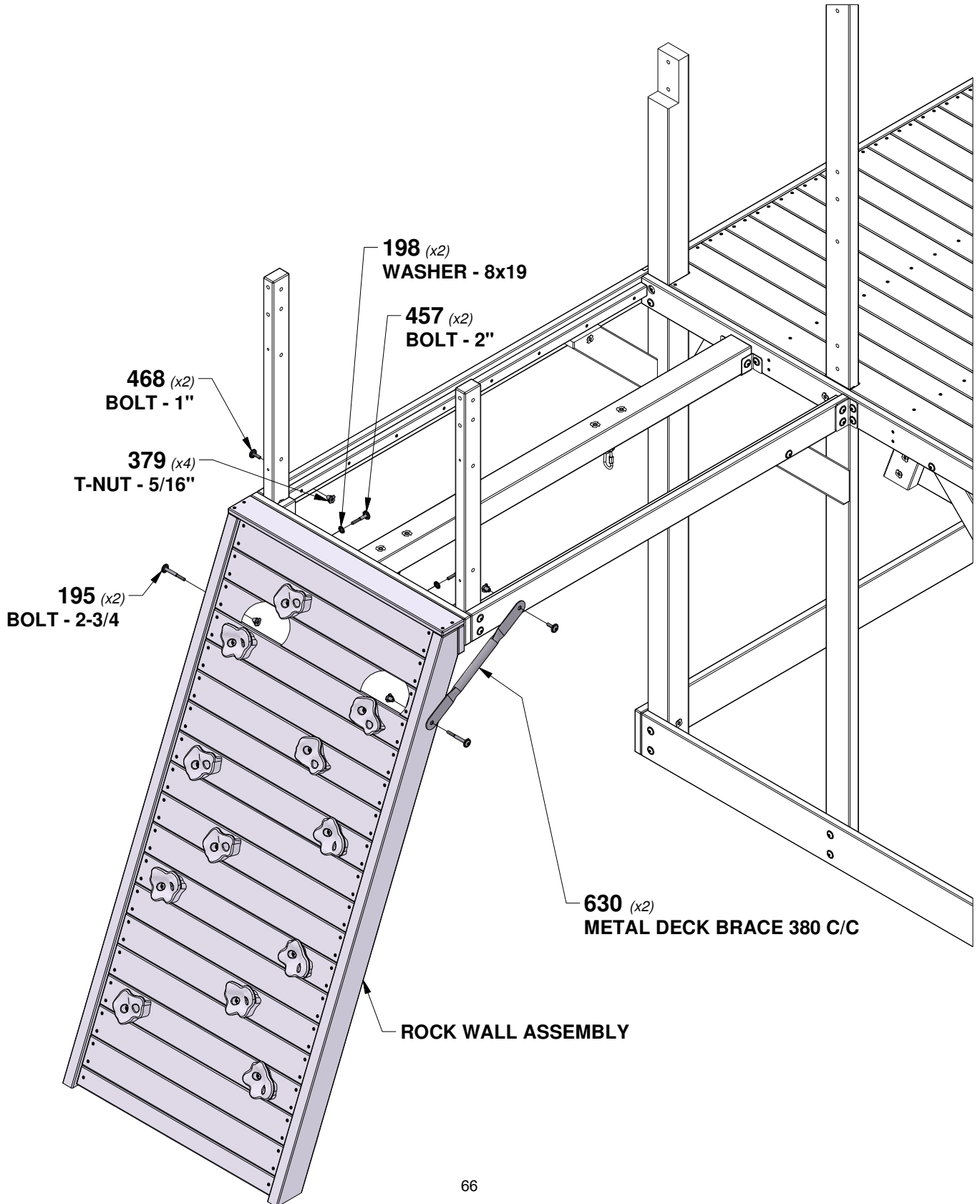

STEP 20 - FORT ASSEMBLY

QTY	PART NUMBER	DESCRIPTION
64	H100086	SCREW PFH 8x1-1/2"



M05 FLOOR BOARD - W4L16649
(x15) 5/8"x3 3/8"x29" (16x86x736)

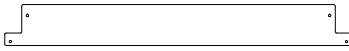

M06 FLOOR BOARD - W4L19023
(x1) 5/8"x3 3/8"x29" (16x86x736)

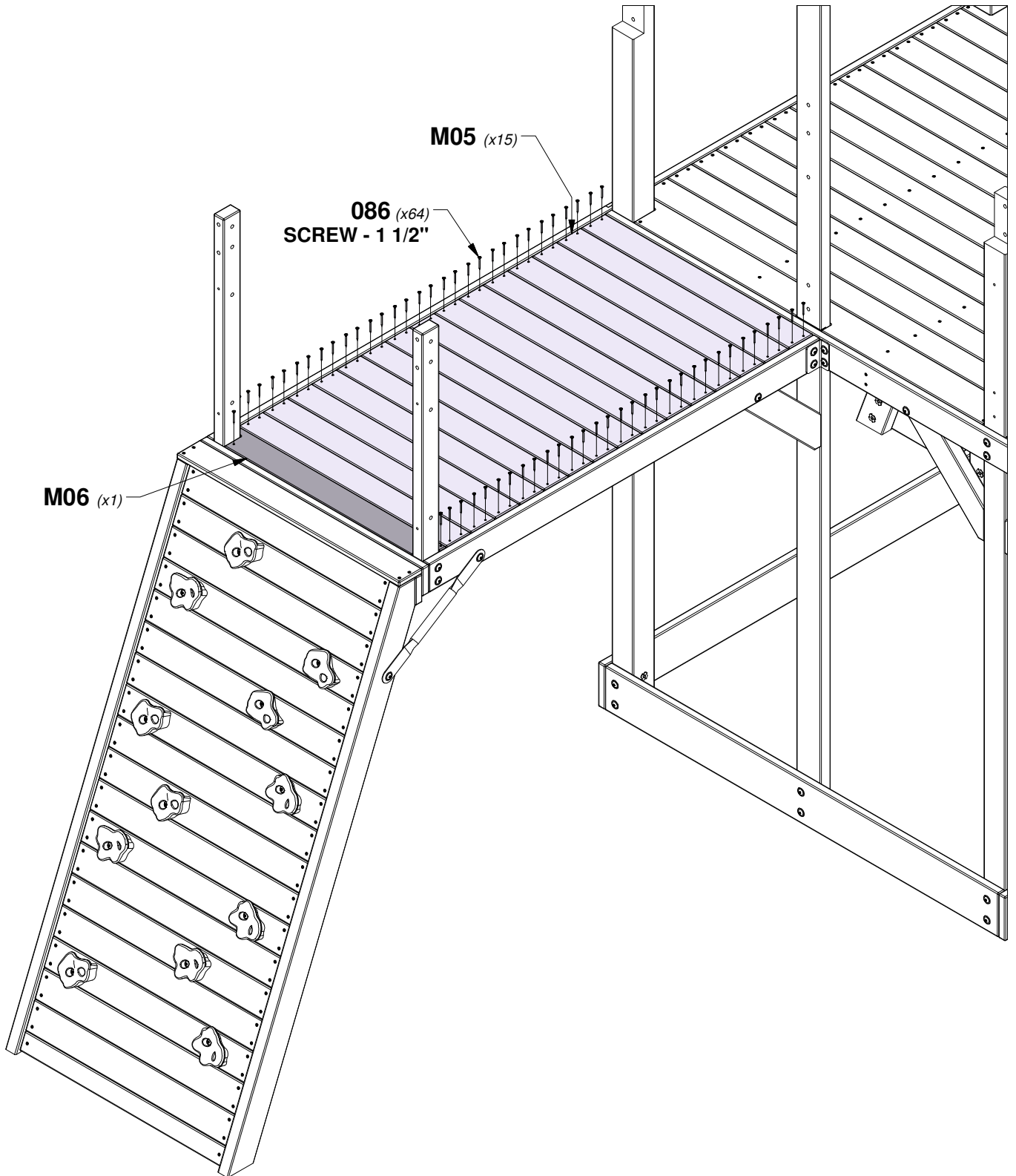

STEP 21 - FORT ASSEMBLY

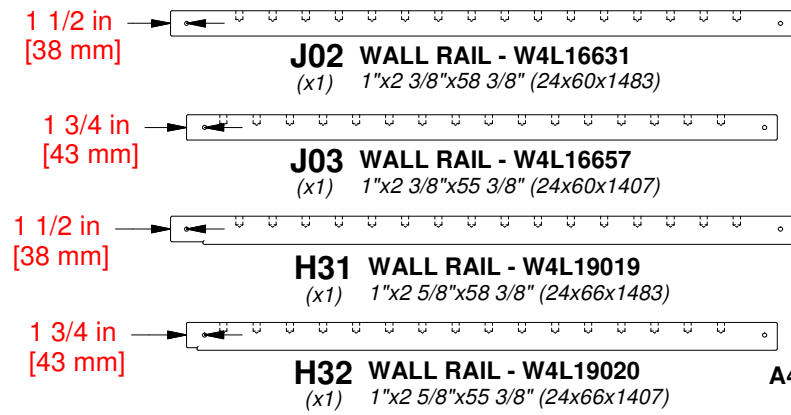

QTY	PART NUMBER	DESCRIPTION
2	H100192	NUT BARREL WH 5/16x7/8 BLK
2	H100197	LAG SCREW WH 5/16x2-1/2 BLK
6	H100198	WASHER LOCK EXT 8x19 BLK
2	H100199	WASHER LOCK EXT 12x19 BLK
4	H100205	BOLT WH 5/16x2-1/4 BLK
6	H100379	T-NUT 5/16 BLK
2	H100396	BOLT WH 5/16x1/2 BLK
2	H100407	BOLT WH 5/16x1 1/2 BLK

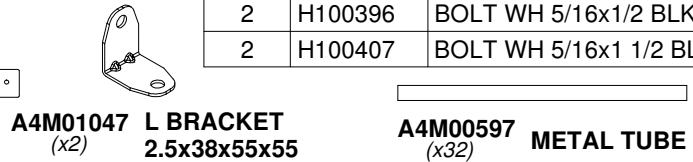

- TIP:**
FOLLOW BELOW ORDER:
1. INSTALL T-NUTS IN WOOD
 2. INSTALL LOWER WALL RAIL BOARDS
 3. INSTALL METAL TUBES
 4. INSTALL TOP WALL RAIL BOARDS

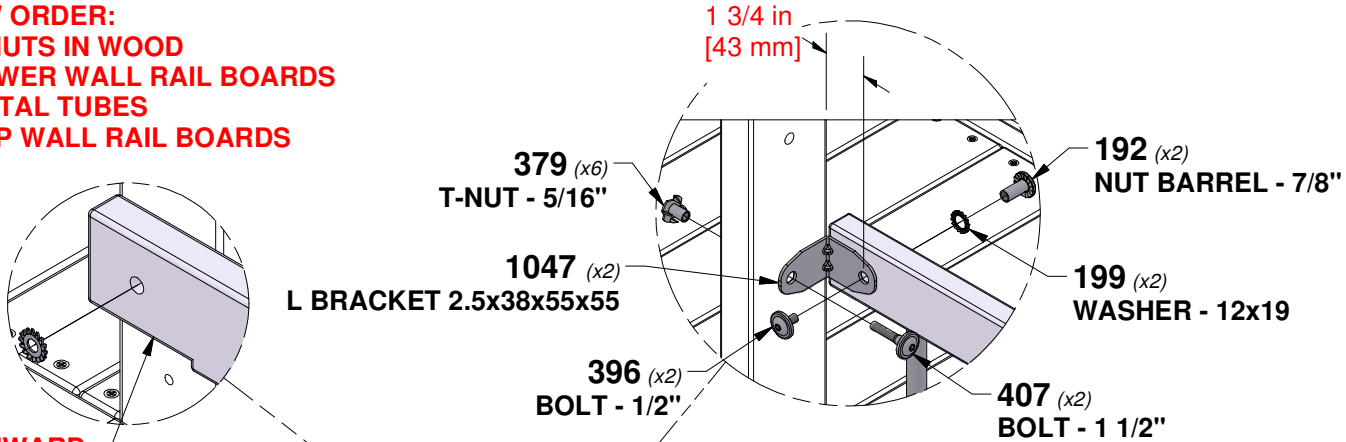

NOTCHES DOWNWARD ON BOTH (H) BOARDS WHEN INSTALLED.

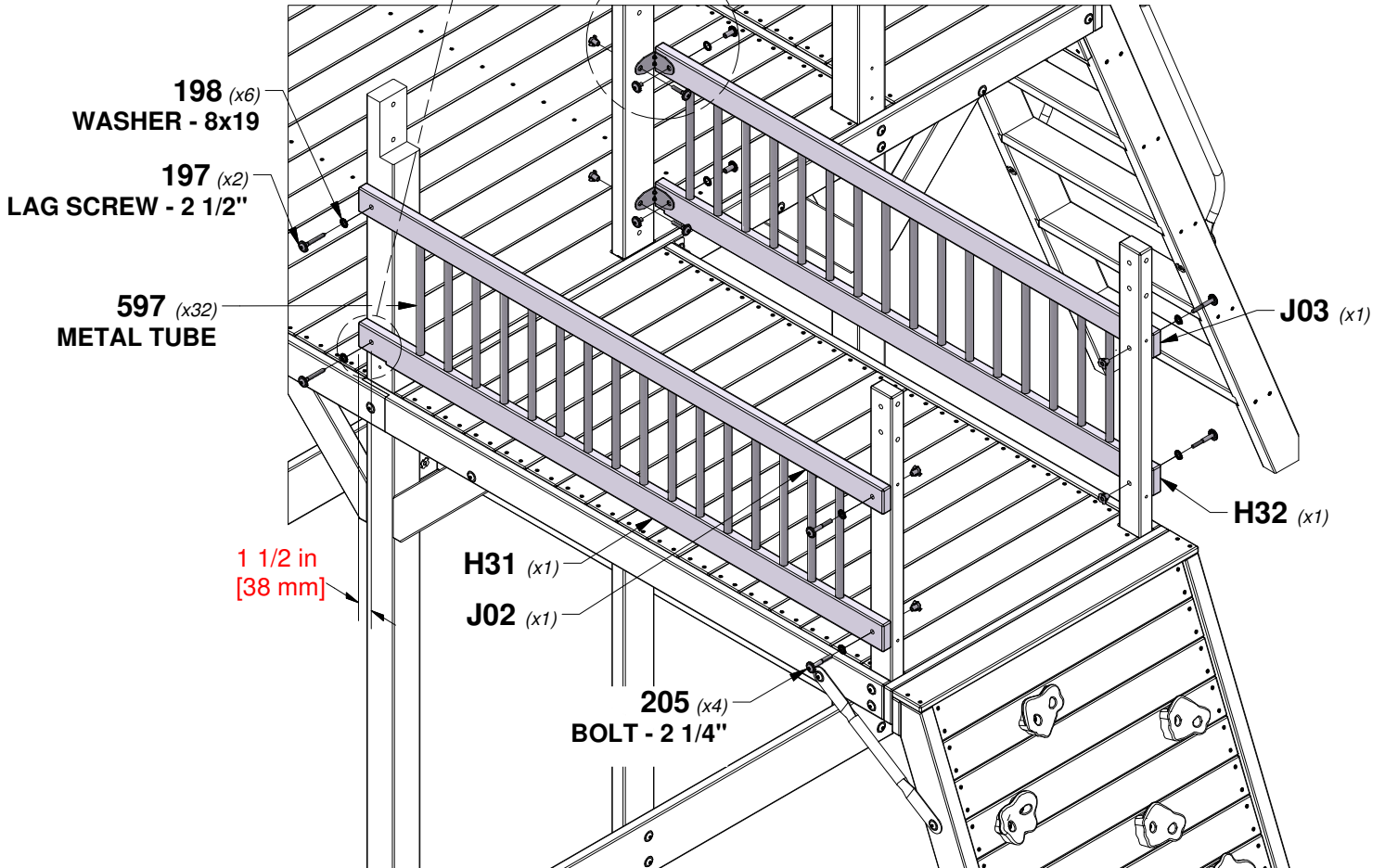

STEP 22 - FORT ASSEMBLY

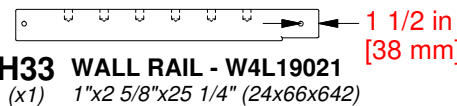
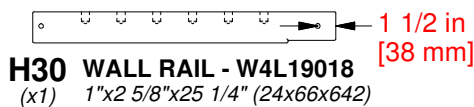
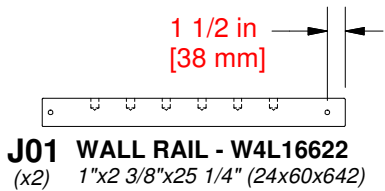

QTY	PART NUMBER	DESCRIPTION
8	H100197	LAG SCREW WH 5/16x2-1/2 BLK
8	H100198	WASHER LOCK EXT 8x19 BLK



- TIP:**
FOLLOW BELOW ORDER:
 1. **INSTALL LOWER WALL RAIL BOARDS**
 2. **INSTALL METAL TUBES**
 3. **INSTALL TOP WALL RAIL BOARDS**

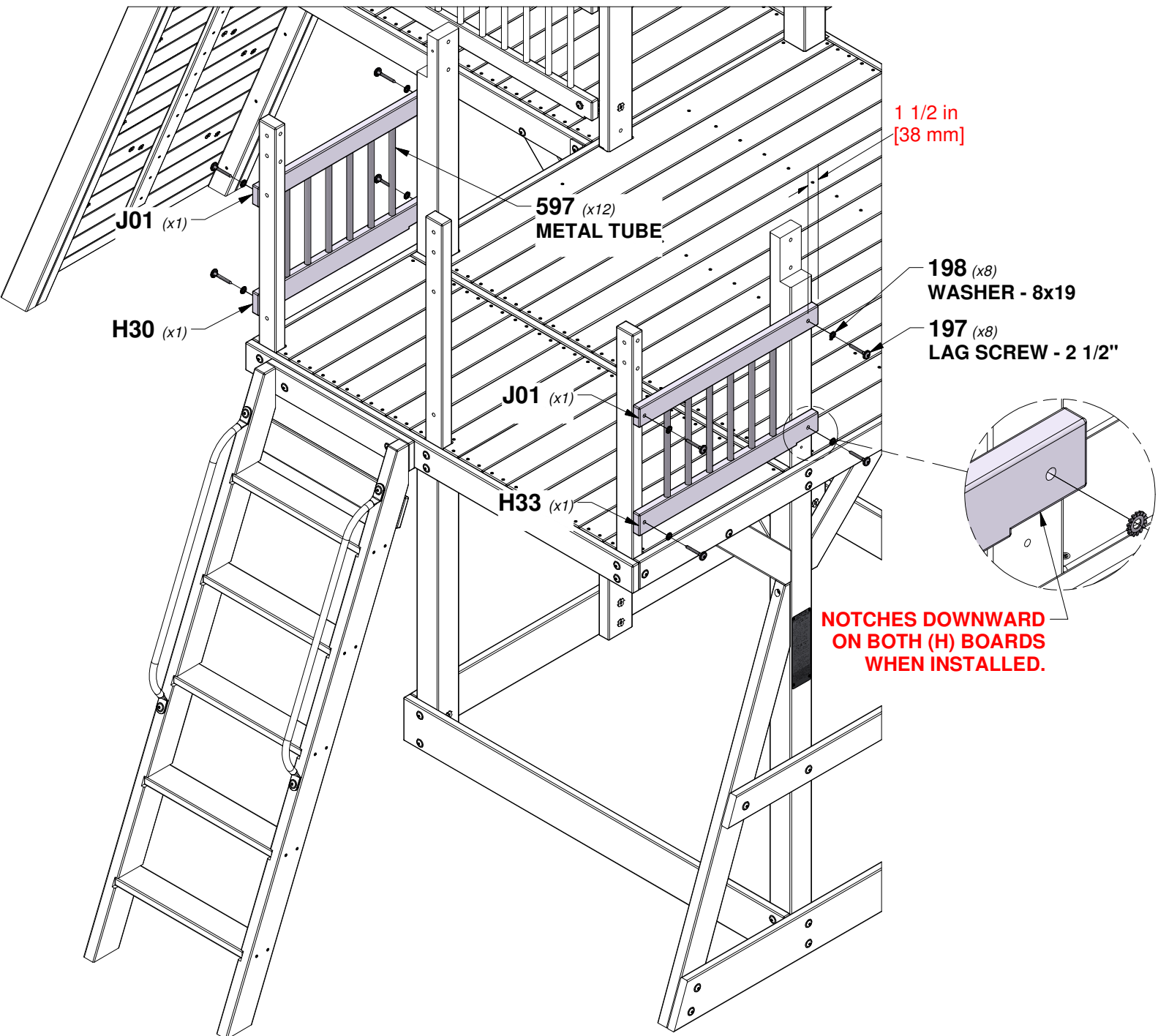

STEP 23 - FORT ASSEMBLY

QTY	PART NUMBER	DESCRIPTION
3	H100197	LAG SCREW WH 5/16x2-1/2 BLK
4	H100198	WASHER LOCK EXT 8x19 BLK
1	H100205	BOLT WH 5/16x2-1/4 BLK
1	H100379	T-NUT 5/16 BLK

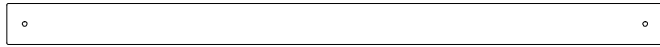

H23 WALL RAIL - W4L16689
(x1) 1"x3 3/8"x54 3/4" (24x86x1390)

1 3/4 in
[43 mm]



H27 WALL RAIL - W4L16656
(x1) 1"x3 3/8"x29" (24x86x738)

TIP:
INSTALL T-NUTS IN WOOD FIRST

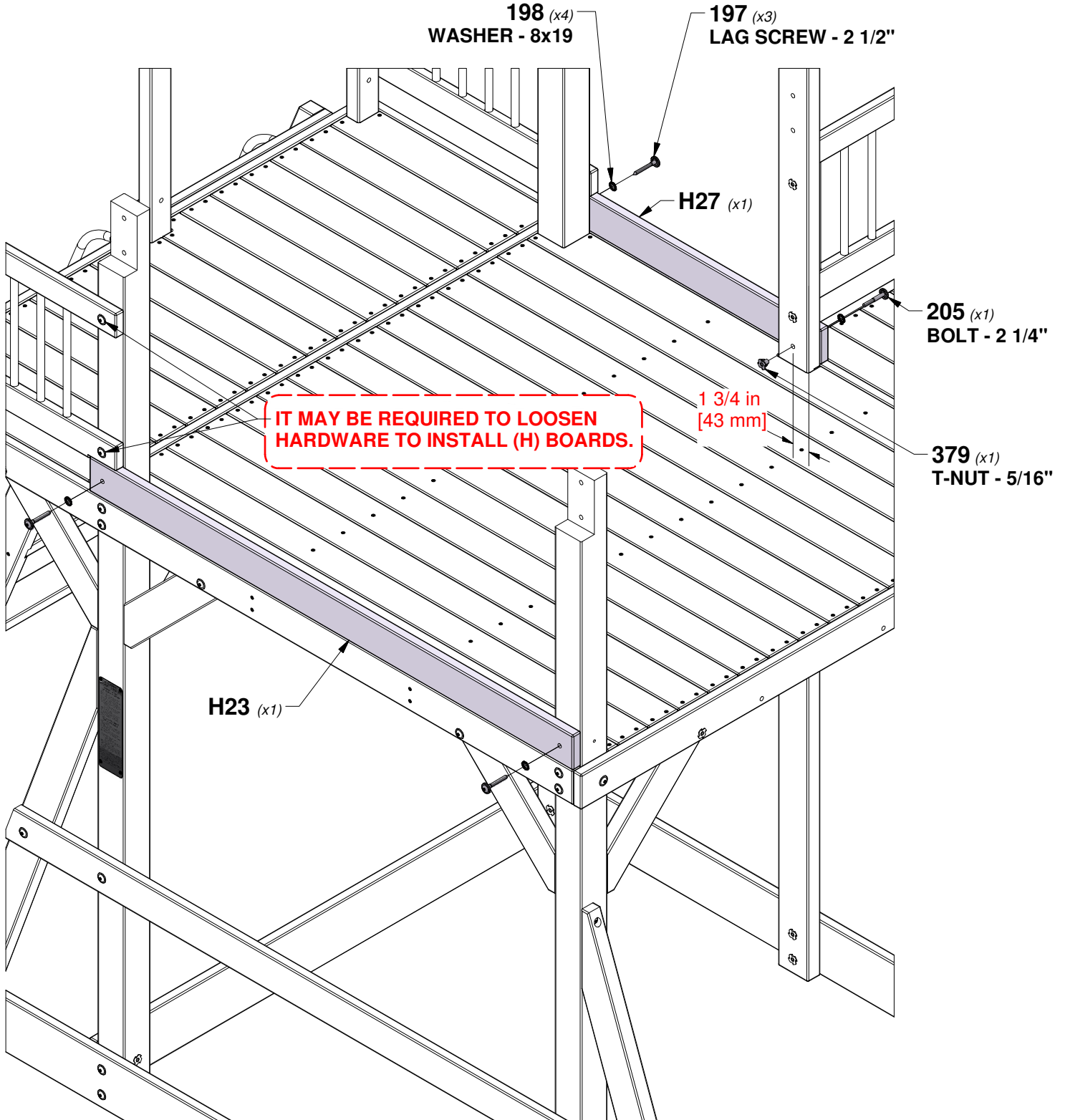

STEP 24 - FORT ASSEMBLY

QTY	PART NUMBER	DESCRIPTION
4	H100198	WASHER LOCK EXT 8x19 BLK
2	H100205	BOLT WH 5/16x2-1/4 BLK
6	H100379	T-NUT 5/16 BLK
2	H100415	BOLT WH 5/16x3 3/4 BLK
2	H100484	BOLT WH 5/16x3 1/4 BLK

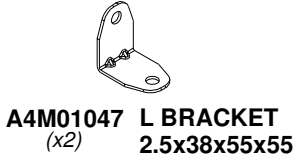
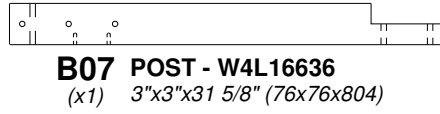
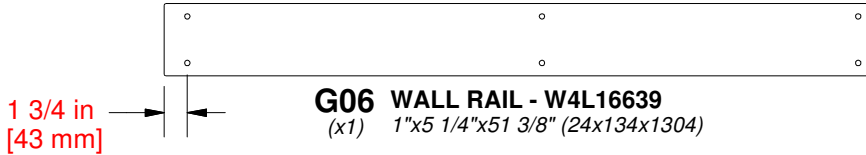

TIP:
INSTALL T-NUTS IN WOOD FIRST

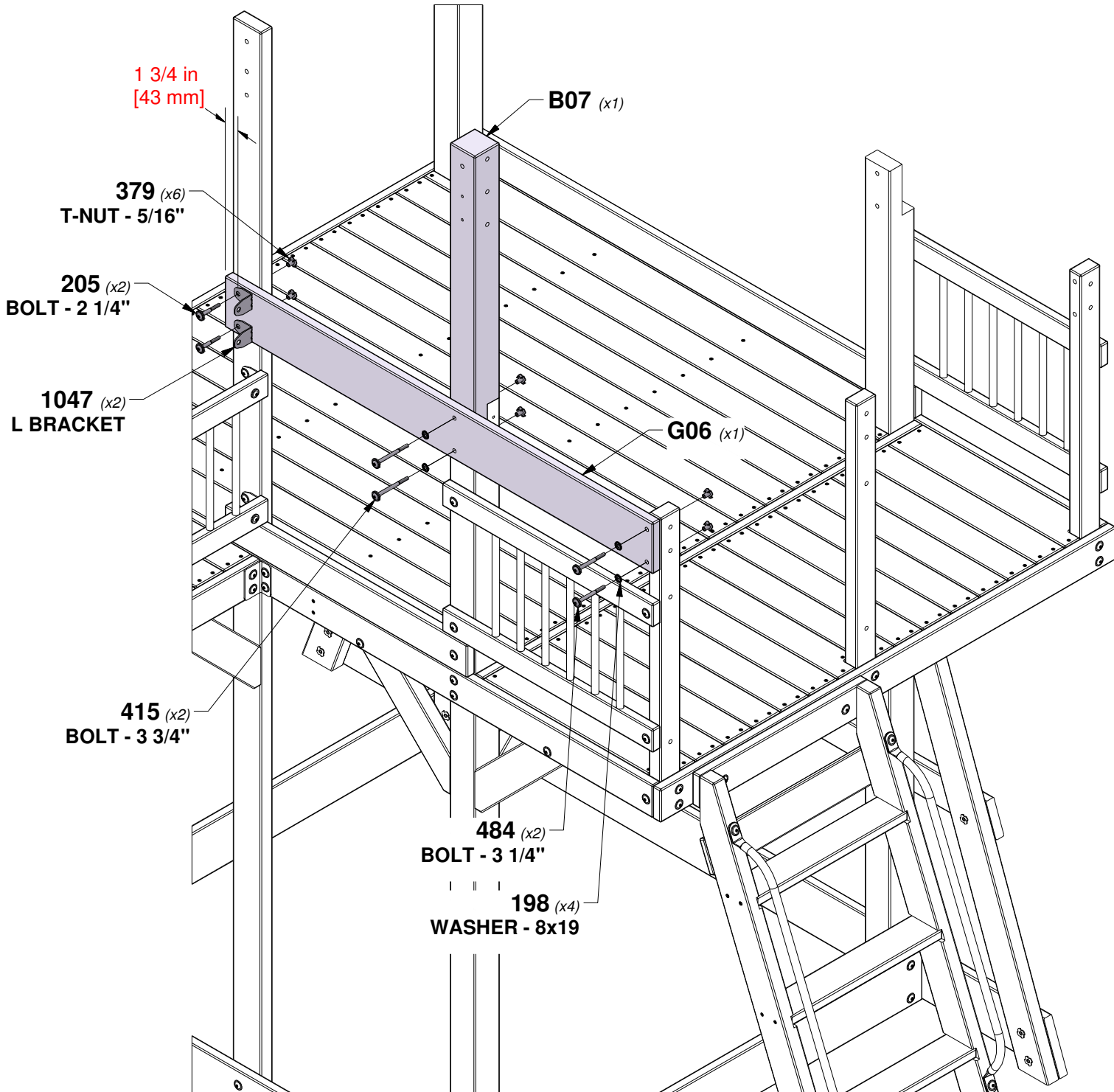

STEP 25 - FORT ASSEMBLY



G07 WALL RAIL - W4L16659
(x1) 1"x5 1/4"x54 1/2" (24x134x1383)

1 3/4 in
[43 mm]

QTY	PART NUMBER	DESCRIPTION
2	H100192	NUT BARREL WH 5/16x7/8 BLK
2	H100198	WASHER LOCK EXT 8x19 BLK
2	H100199	WASHER LOCK EXT 12x19 BLK
2	H100205	BOLT WH 5/16x2-1/4 BLK
2	H100379	T-NUT 5/16 BLK
2	H100396	BOLT WH 5/16x1/2 BLK

TIP:
INSTALL T-NUTS IN WOOD FIRST

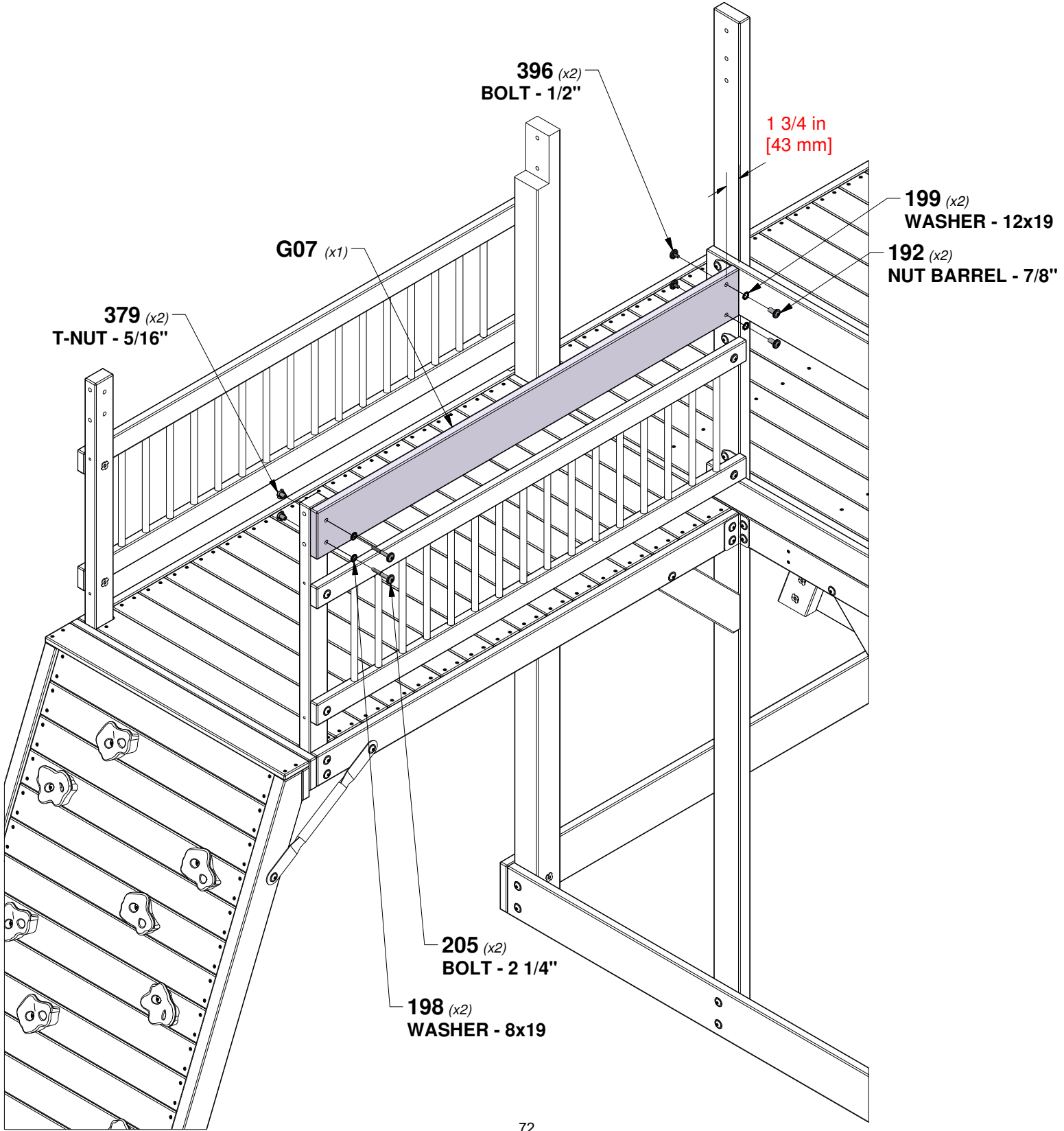

STEP 26 - FORT ASSEMBLY



G10 WALL RAIL - W4L16662
 (x1) 1"x5 1/4"x31" (24x134x786)

QTY	PART NUMBER	DESCRIPTION
4	H100198	WASHER LOCK EXT 8x19 BLK
4	H100379	T-NUT 5/16 BLK
4	H100484	BOLT WH 5/16x3 1/4 BLK

TIP:
INSTALL T-NUTS IN WOOD FIRST

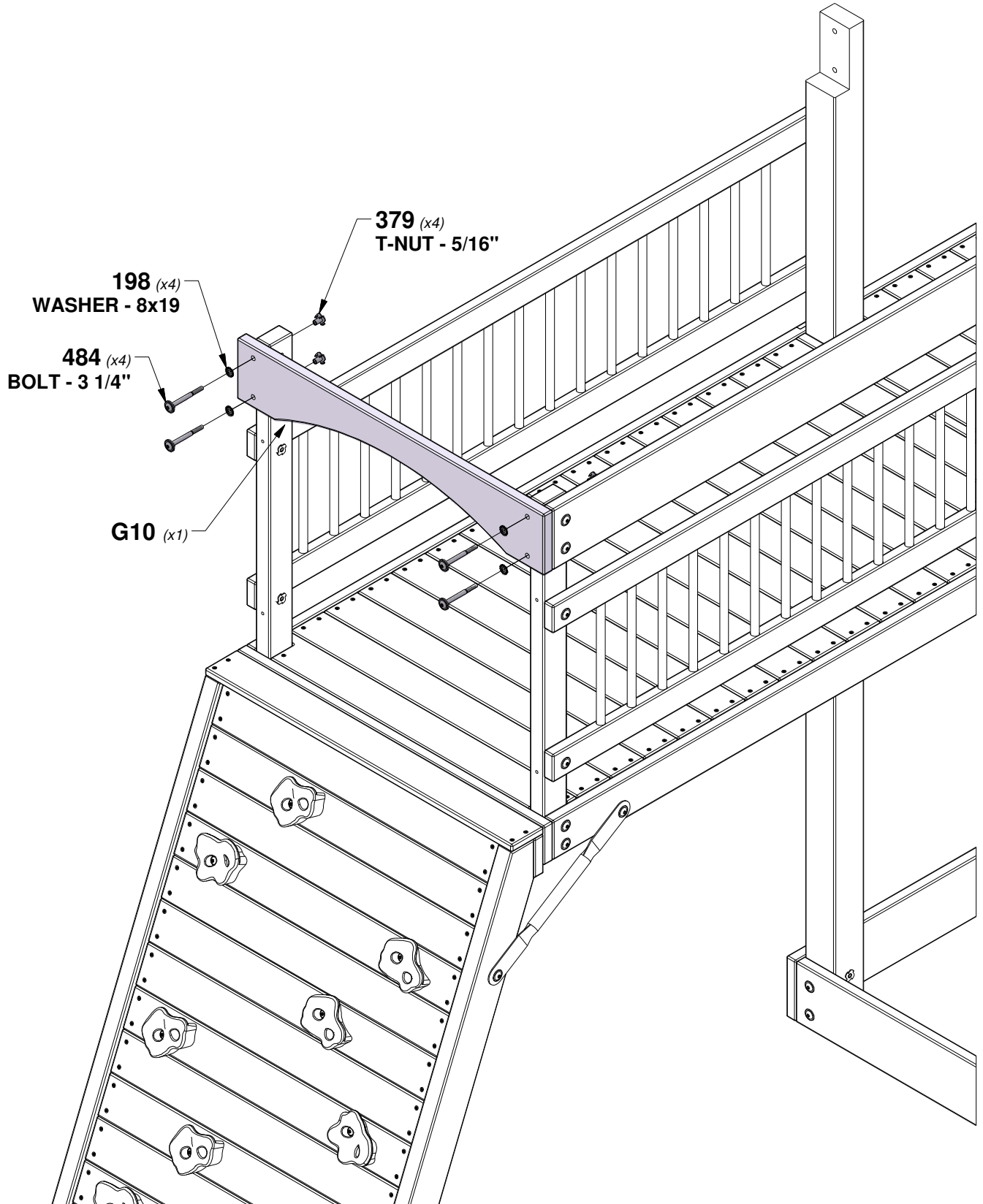

STEP 27 - FORT ASSEMBLY

QTY	PART NUMBER	DESCRIPTION
6	H100198	WASHER LOCK EXT 8x19 BLK
6	H100205	BOLT WH 5/16x2-1/4 BLK
6	H100379	T-NUT 5/16 BLK

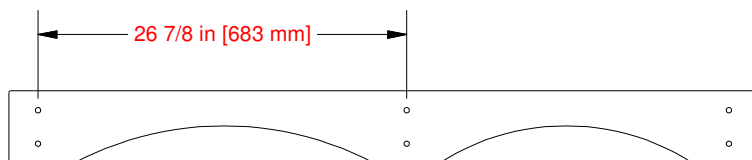

G05 WALL RAIL - W4L16623
 (x1) 1"x5 1/4"x54 5/8" (24x134x1388)

TIP:
INSTALL T-NUTS IN WOOD FIRST

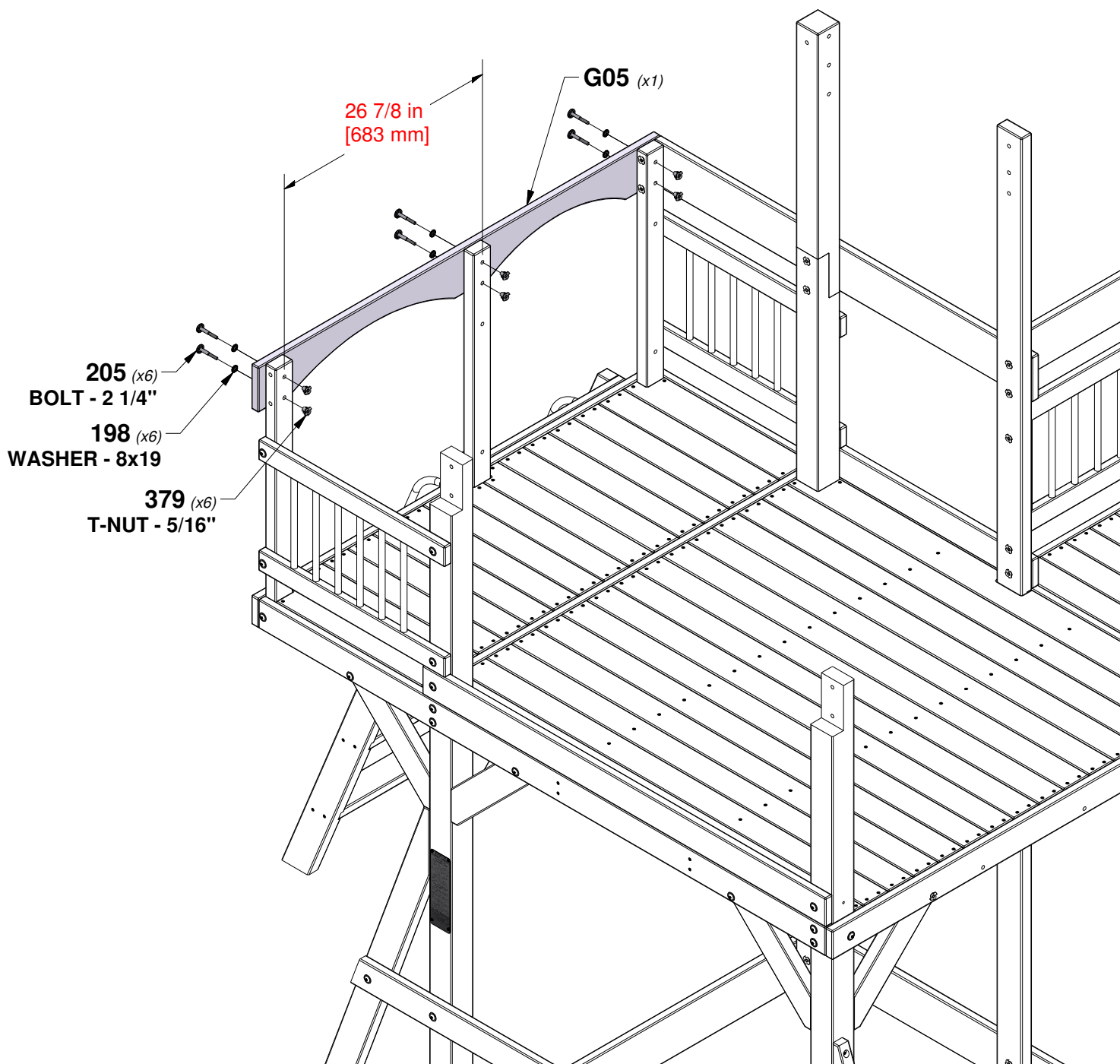

STEP 28 - FORT ASSEMBLY



B05 POST - W4L16634
(x1) 3"x3"x31 5/8" (76x76x804)

B06 POST - W4L16635
(x1) 3"x3"x31 5/8" (76x76x804)



G04 WALL RAIL - W4L16602
(x1) 1"x5 1/4"x77" (24x134x1956)

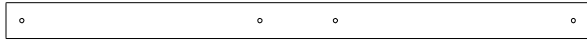

H12 WALL RAIL - W4L16655
(x1) 1"x3 3/8"x54 3/4" (24x86x1390)

QTY	PART NUMBER	DESCRIPTION
8	H100198	WASHER LOCK EXT 8x19 BLK
12	H100379	T-NUT 5/16 BLK
6	H100415	BOLT WH 5/16x3 3/4 BLK
2	H100484	BOLT WH 5/16x3 1/4 BLK

TIP:
INSTALL T-NUTS IN WOOD FIRST

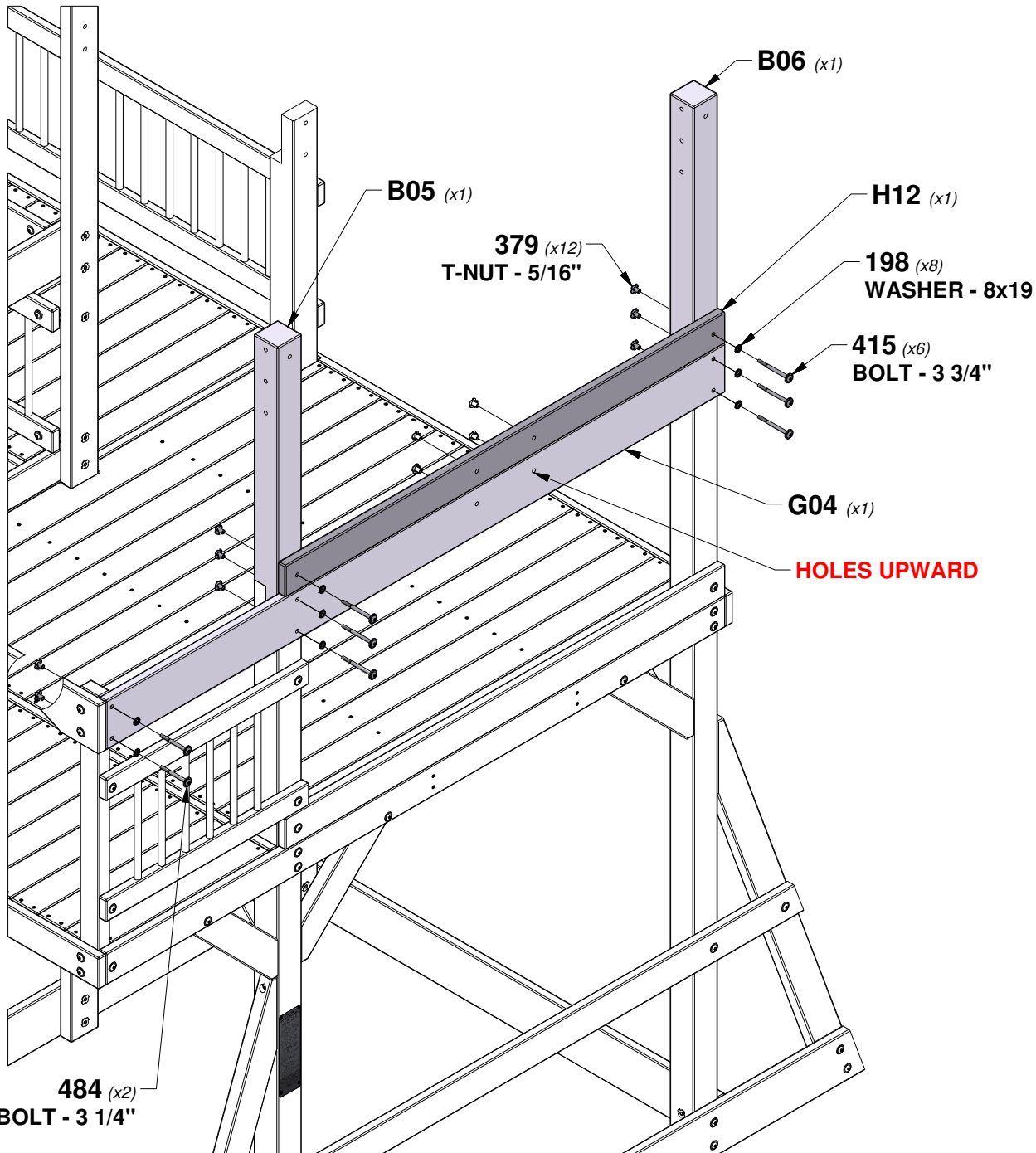

STEP 29 - FORT ASSEMBLY

QTY	PART NUMBER	DESCRIPTION
1	H100192	NUT BARREL WH 5/16x7/8 BLK
2	H100197	LAG SCREW WH 5/16x2-1/2 BLK
3	H100198	WASHER LOCK EXT 8x19 BLK
1	H100199	WASHER LOCK EXT 12x19 BLK
1	H100378	BOLT WH 5/16x1 3/4 BLK
2	H100379	T-NUT 5/16 BLK
1	H100396	BOLT WH 5/16x1/2 BLK
1	H100407	BOLT WH 5/16x1 1/2 BLK

H24 WALL BOARD - W4L16690
(x1) 1"x3 3/8"x50 1/8" (24x86x1274)



A4M01047 L BRACKET
(x1) 2.5x38x55x55

1 3/4 in
[43 mm]

1 3/4 in
[43 mm]

H25 WALL RAIL - W4L16691
(x1) 1"x3 3/8"x29" (24x86x737)

H26 WALL RAIL - W4L16692
(x1) 1"x3 3/8"x28 1/8" (24x86x713)

TIP:
INSTALL T-NUTS IN WOOD FIRST

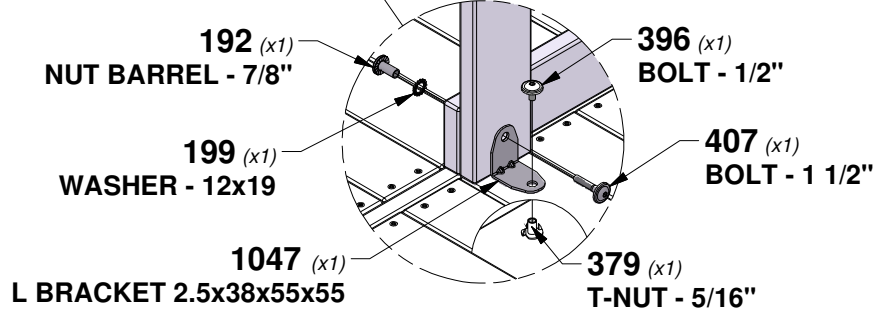
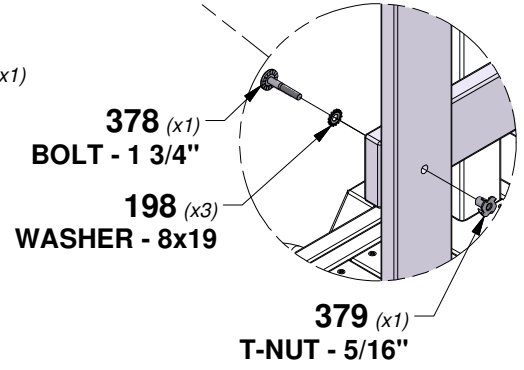
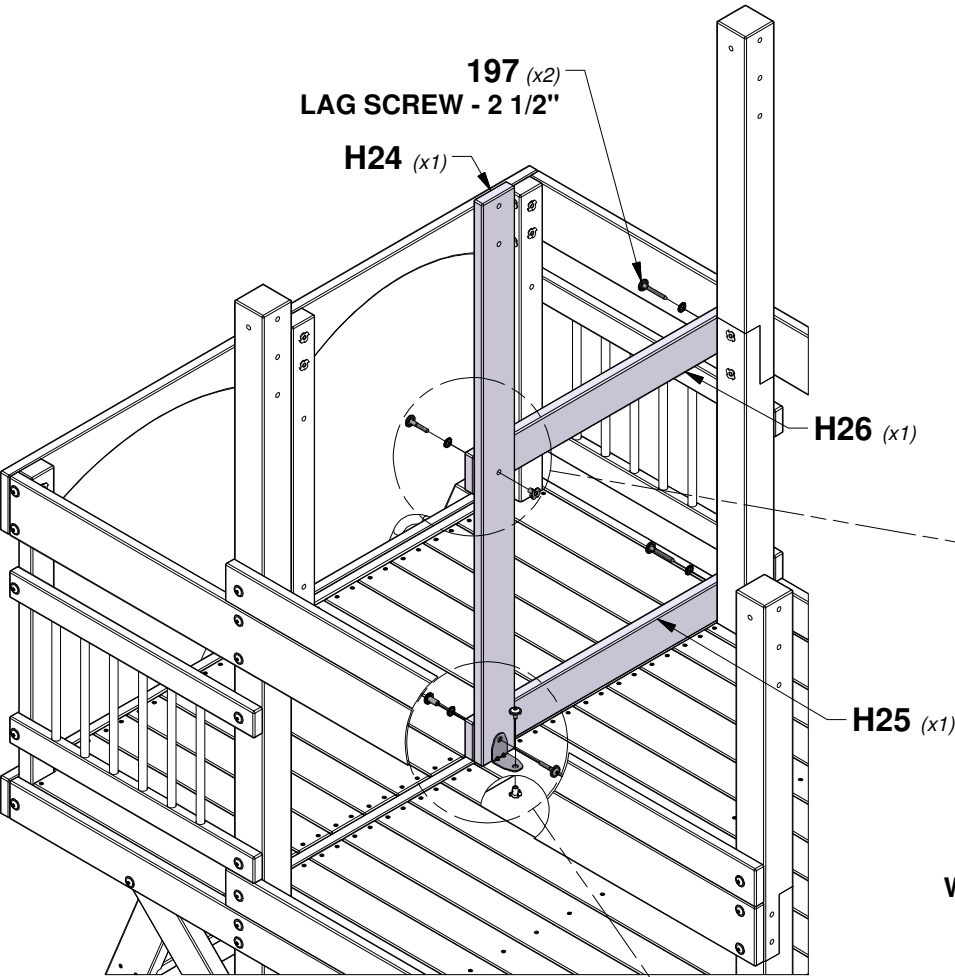
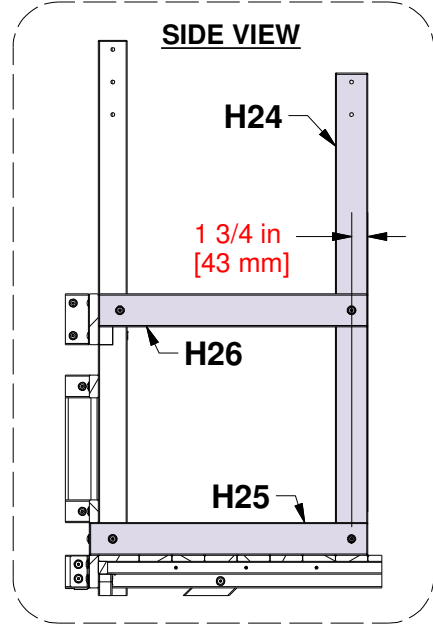

USING BRACKET AS A GUIDE, DRILL (1) 3/8" [10mm] HOLE THRU DECK FOR HARDWARE.

STEP 30 - FORT ASSEMBLY



B08 POST - W4L16637
 (x1) 3"x3"x31 5/8" (76x76x804)

QTY	PART NUMBER	DESCRIPTION
2	H100198	WASHER LOCK EXT 8x19 BLK
2	H100379	T-NUT 5/16 BLK
2	H100416	BOLT WH 5/16x3 BLK

TIP:
INSTALL T-NUTS IN WOOD FIRST

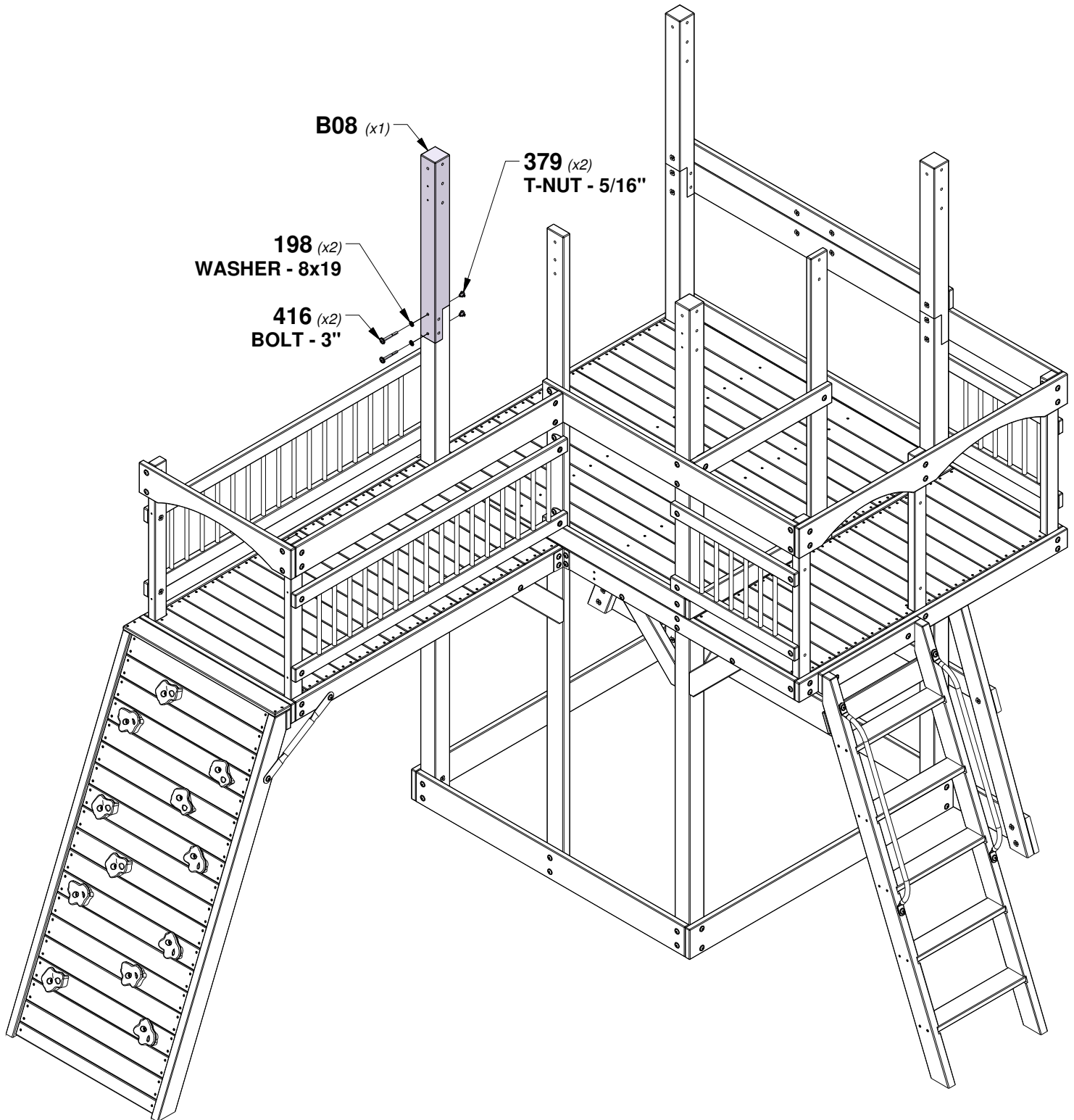

STEP 31 - FORT ASSEMBLY

QTY	PART NUMBER	DESCRIPTION
6	H100198	WASHER LOCK EXT 8x19 BLK
2	H100205	BOLT WH 5/16x2-1/4 BLK
6	H100379	T-NUT 5/16 BLK
4	H100415	BOLT WH 5/16x3 3/4 BLK

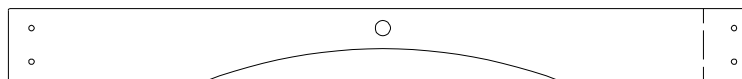

G08 WALL RAIL - W4L16660
(x1) 1"x5 1/4"x53 3/4" (24x134x1364)



G09 WALL RAIL - W4L16661
(x1) 1"x5 1/4"x58 3/8" (24x134x1483)

TIP:
INSTALL T-NUTS IN WOOD FIRST

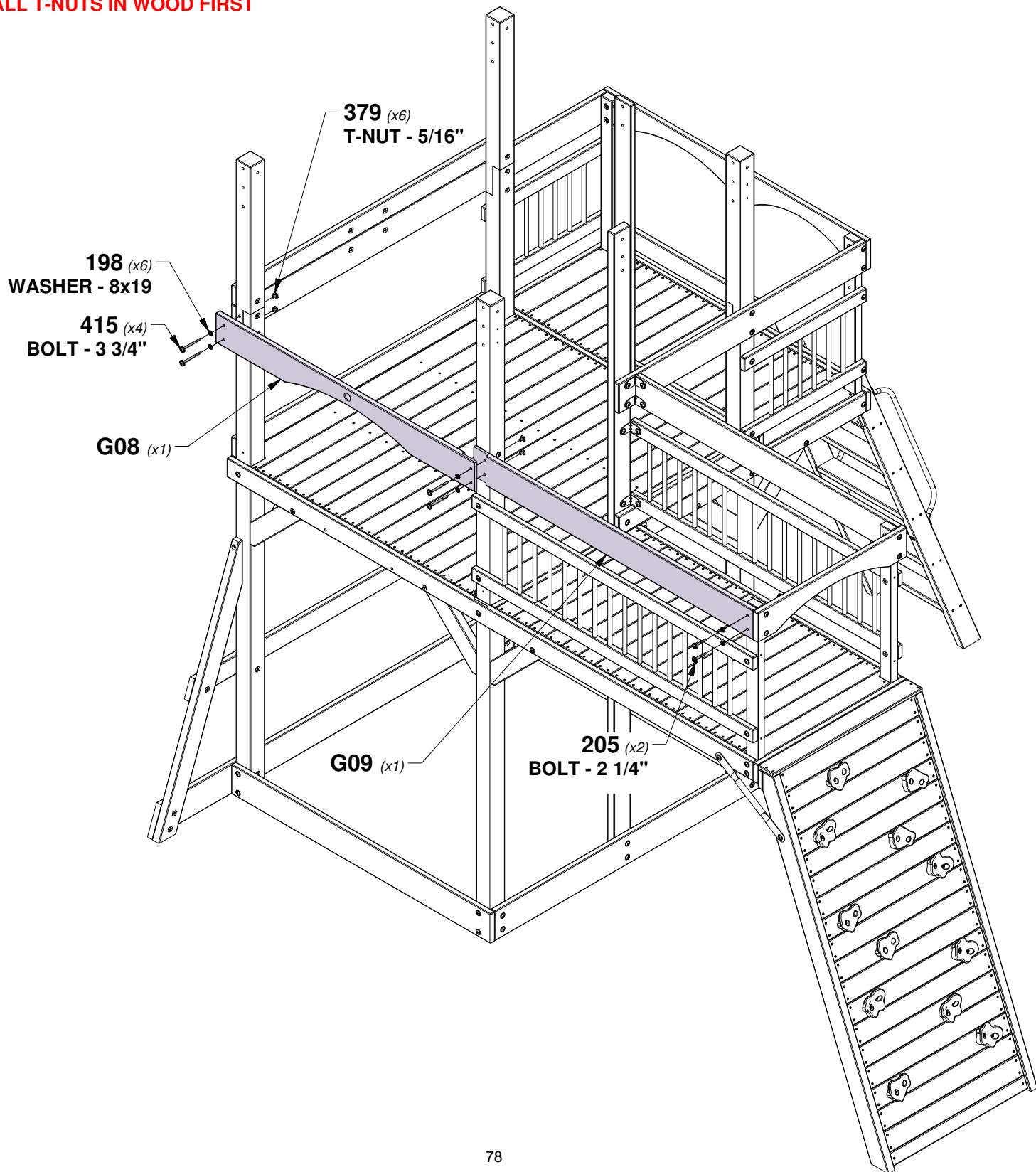

STEP 32 - FORT ASSEMBLY

1 3/4 in
[43 mm]

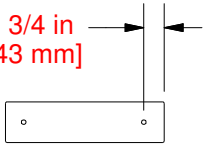

1 3/4 in
[43 mm]

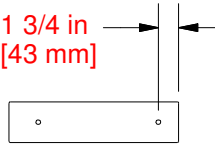

H28 WALL RAIL - W4L16625
(x1) 1"x3 3/8"x13 1/4" (24x86x336)

H29 WALL RAIL - W4L16699
(x1) 1"x3 3/8"x14 1/8" (24x86x360)

QTY	PART NUMBER	DESCRIPTION
2	H100197	LAG SCREW WH 5/16x2-1/2 BLK
2	H100198	WASHER LOCK EXT 8x19 BLK

198 (x2)
WASHER - 8x19

197 (x2)
LAG SCREW - 2 1/2"

H29 (x1)

1 3/4 in
[43 mm]

H28 (x1)

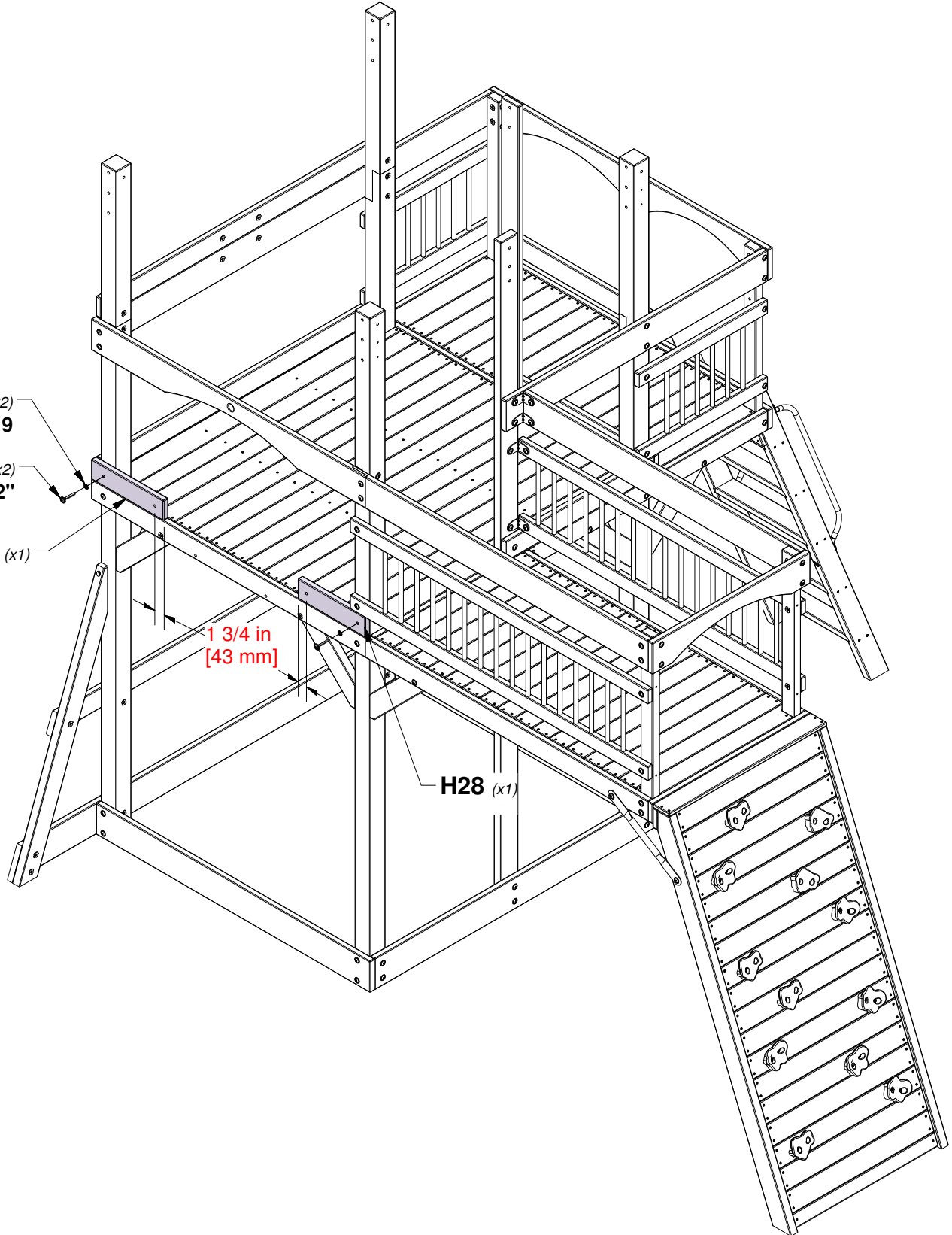

STEP 33 - FORT ASSEMBLY



H22 WALL RAIL - W4L16688
(x1) 1"x3 3/8"x54 3/4" (24x86x1390)



H23 WALL RAIL - W4L16689
(x1) 1"x3 3/8"x54 3/4" (24x86x1390)

QTY	PART NUMBER	DESCRIPTION
5	H100198	WASHER LOCK EXT 8x19 BLK
1	H100205	BOLT WH 5/16x2-1/4 BLK
5	H100379	T-NUT 5/16 BLK
4	H100415	BOLT WH 5/16x3 3/4 BLK

TIP:
INSTALL T-NUTS IN WOOD FIRST

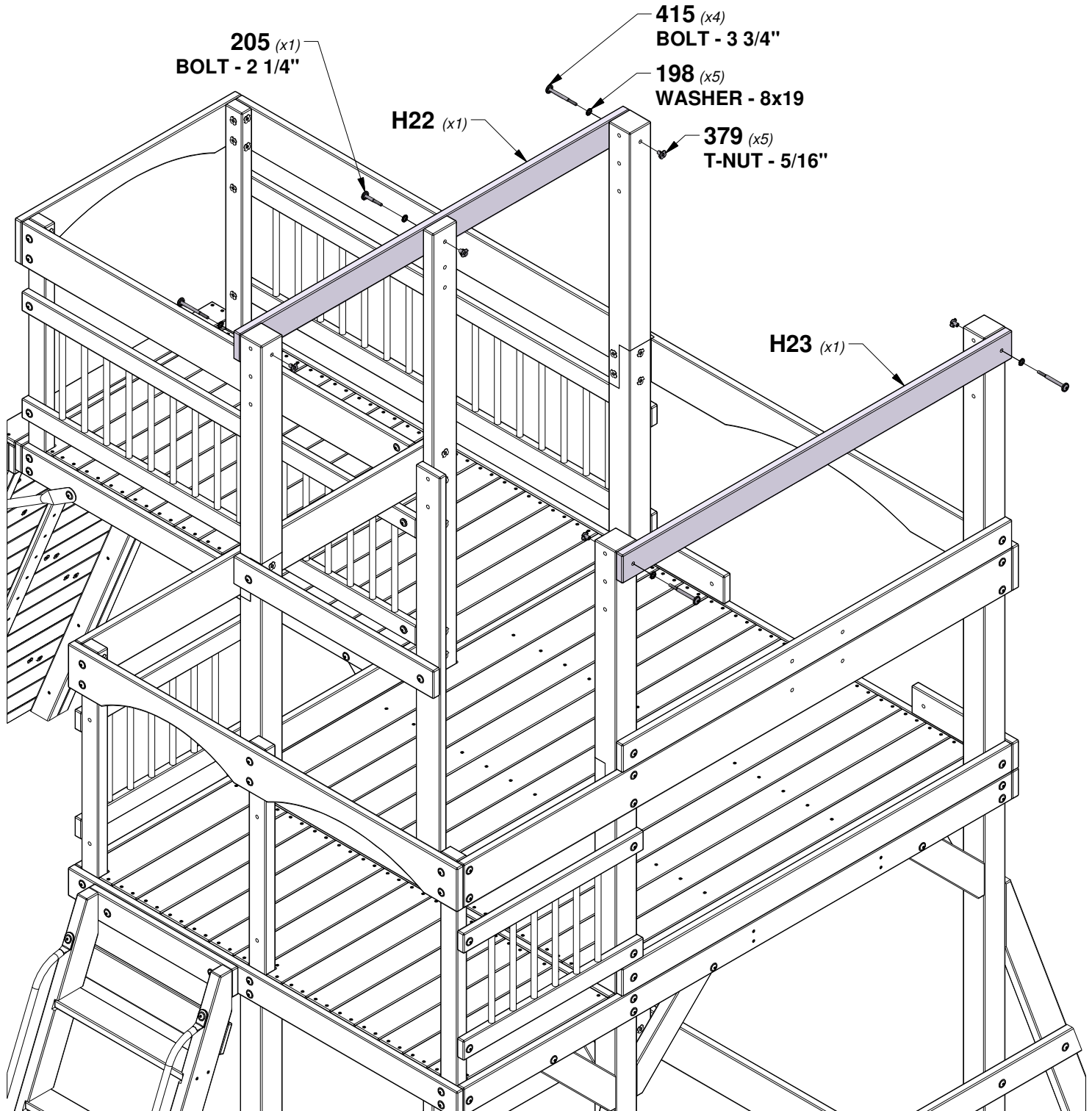

STEP 34 - FORT ASSEMBLY

QTY	PART NUMBER	DESCRIPTION
10	H100198	WASHER LOCK EXT 8x19 BLK
10	H100379	T-NUT 5/16 BLK
2	H100407	BOLT WH 5/16x1 1/2 BLK
8	H100503	BOLT WH 5/16x3-1/2 BLK



K01 WALL RAIL - W4L16640
(x1) 5/8"x5 1/4"x52 3/4" (16x134x1340)

2 1/8 in
[54 mm]

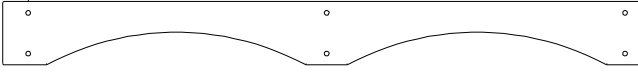

K02 WALL RAIL - W4L16641
(x1) 5/8"x5 1/4"x53 3/8" (16x134x1356)

TIP:
INSTALL T-NUTS IN WOOD FIRST

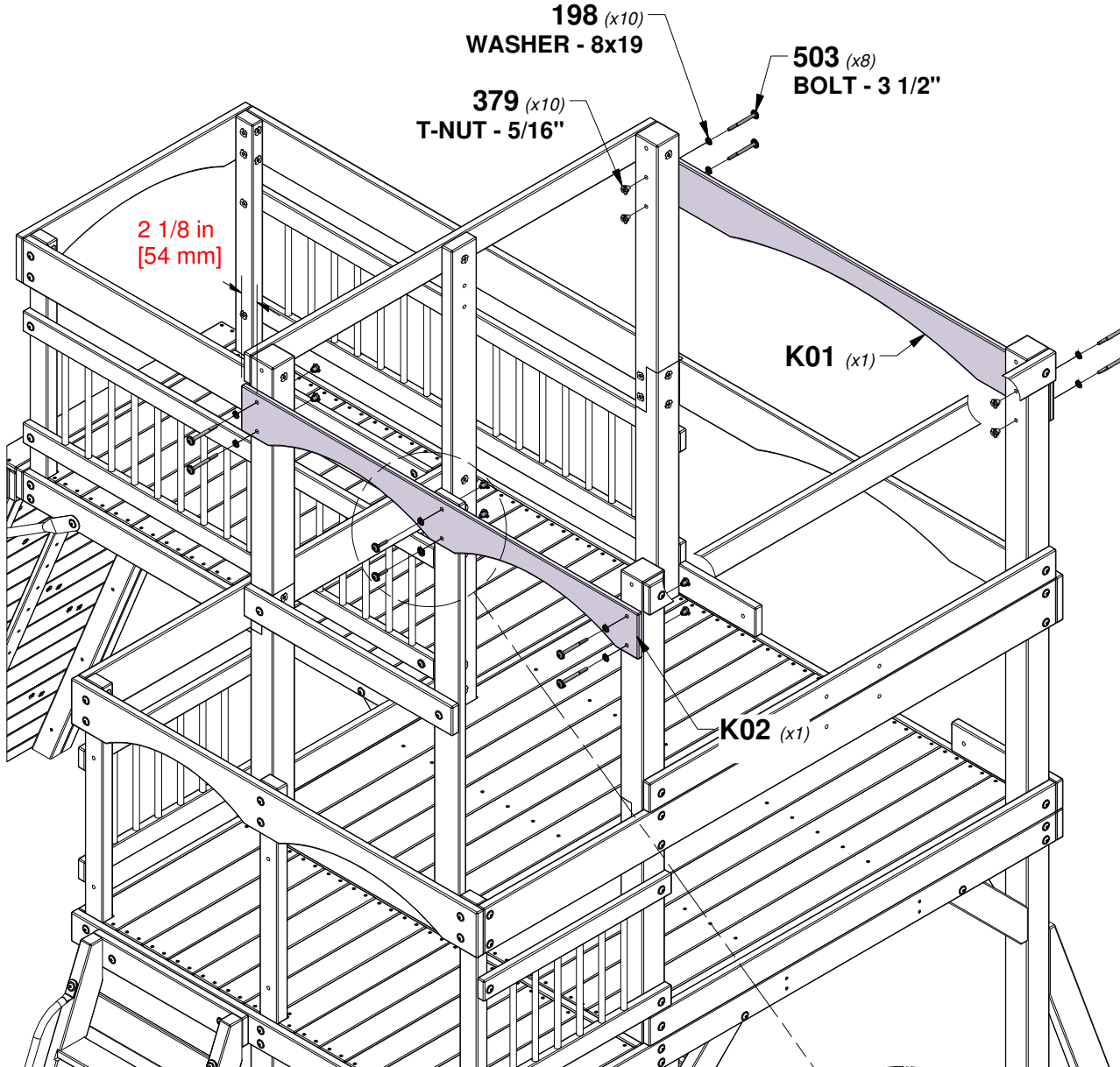

407 (x2)
BOLT - 1 1/2"

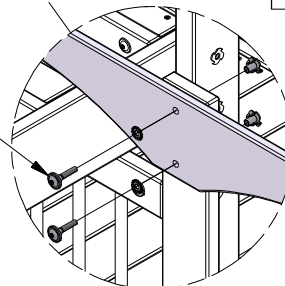

STEP 35 - FORT ASSEMBLY

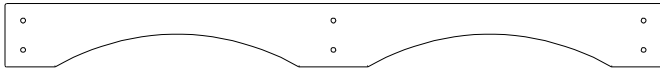

K03 WALL RAIL - W4L16658
 (x1) 5/8"x5 1/4"x54 3/4" (16x134x1390)

QTY	PART NUMBER	DESCRIPTION
6	H100198	WASHER LOCK EXT 8x19 BLK
2	H100379	T-NUT 5/16 BLK
2	H100457	BOLT WH 5/16x2 BLK
4	H100458	LAG SCREW WH 5/16x2 BLK

TIP:
INSTALL T-NUTS IN WOOD FIRST

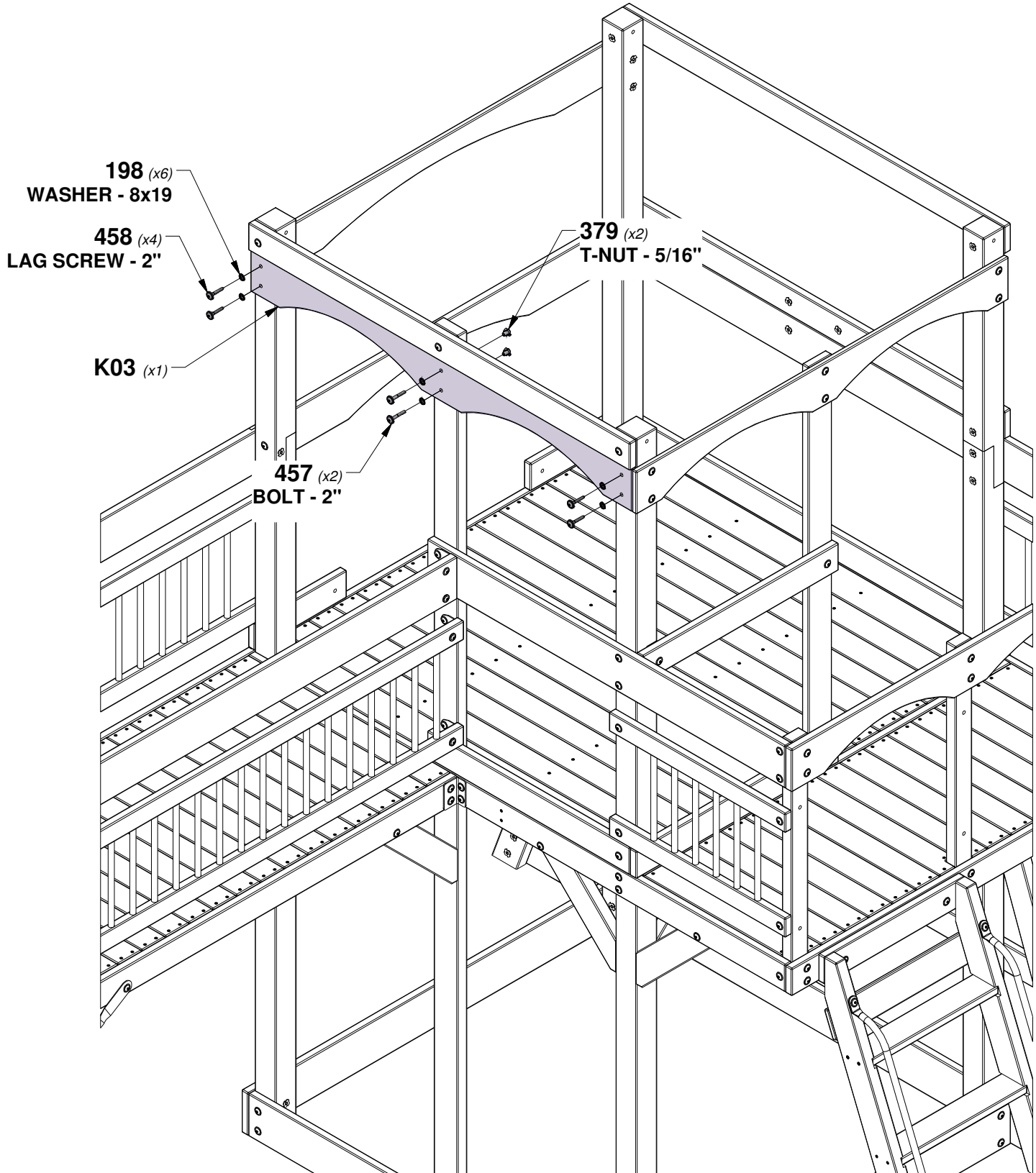

STEP 36 - FORT ASSEMBLY



H13 WALL RAIL - W4L16664
(x2) 1"x3 3/8"x26 7/8" (24x86x684)



A4M01047 L BRACKET
(x2) 2.5x38x55x55



M10 WALL BOARD - W4L16663
(x4) 5/8"x3 3/8"x53 1/4" (16x86x1354)

QTY	PART NUMBER	DESCRIPTION
16	H100087	SCREW PFH 8x1-1/4"
4	H100089	SCREW PFH 8x1-3/4"
2	H100192	NUT BARREL WH 5/16x7/8 BLK
2	H100199	WASHER LOCK EXT 12x19 BLK
2	H100379	T-NUT 5/16 BLK
2	H100396	BOLT WH 5/16x1/2 BLK
2	H100407	BOLT WH 5/16x1 1/2 BLK

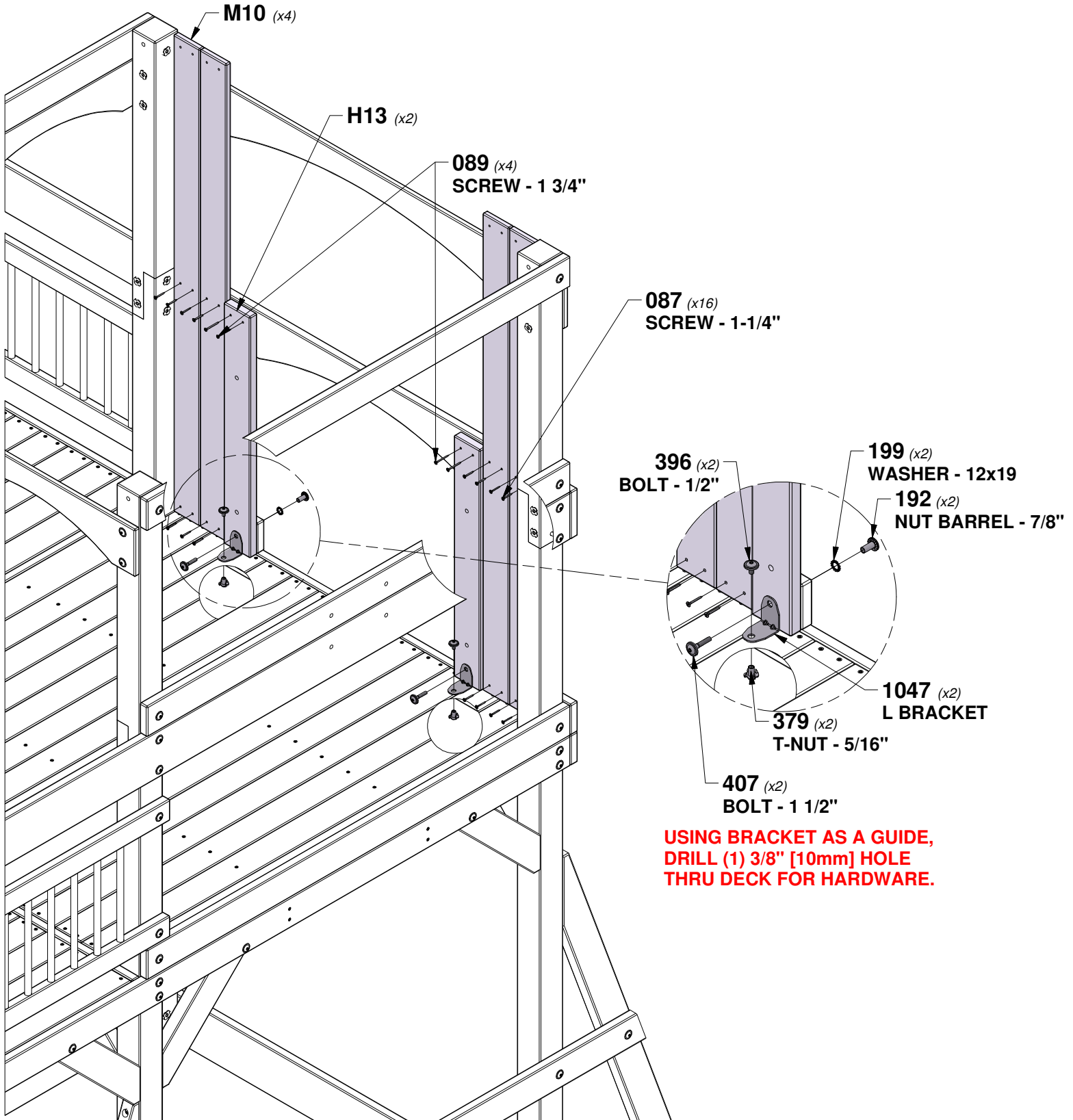

STEP 37 - FORT ASSEMBLY

QTY	PART NUMBER	DESCRIPTION
84	H100087	SCREW PFH 8x1-1/4"



M07 WALL BOARD - W4L16652
(x12) 5/8"x3 3/8"x29" (16x86x736)



Y02 WALL BOARD - W4L16653
(x2) 5/8"x3 7/8"x29" (16x99x736)

TIP:
EVENLY SPACE WALL BOARDS

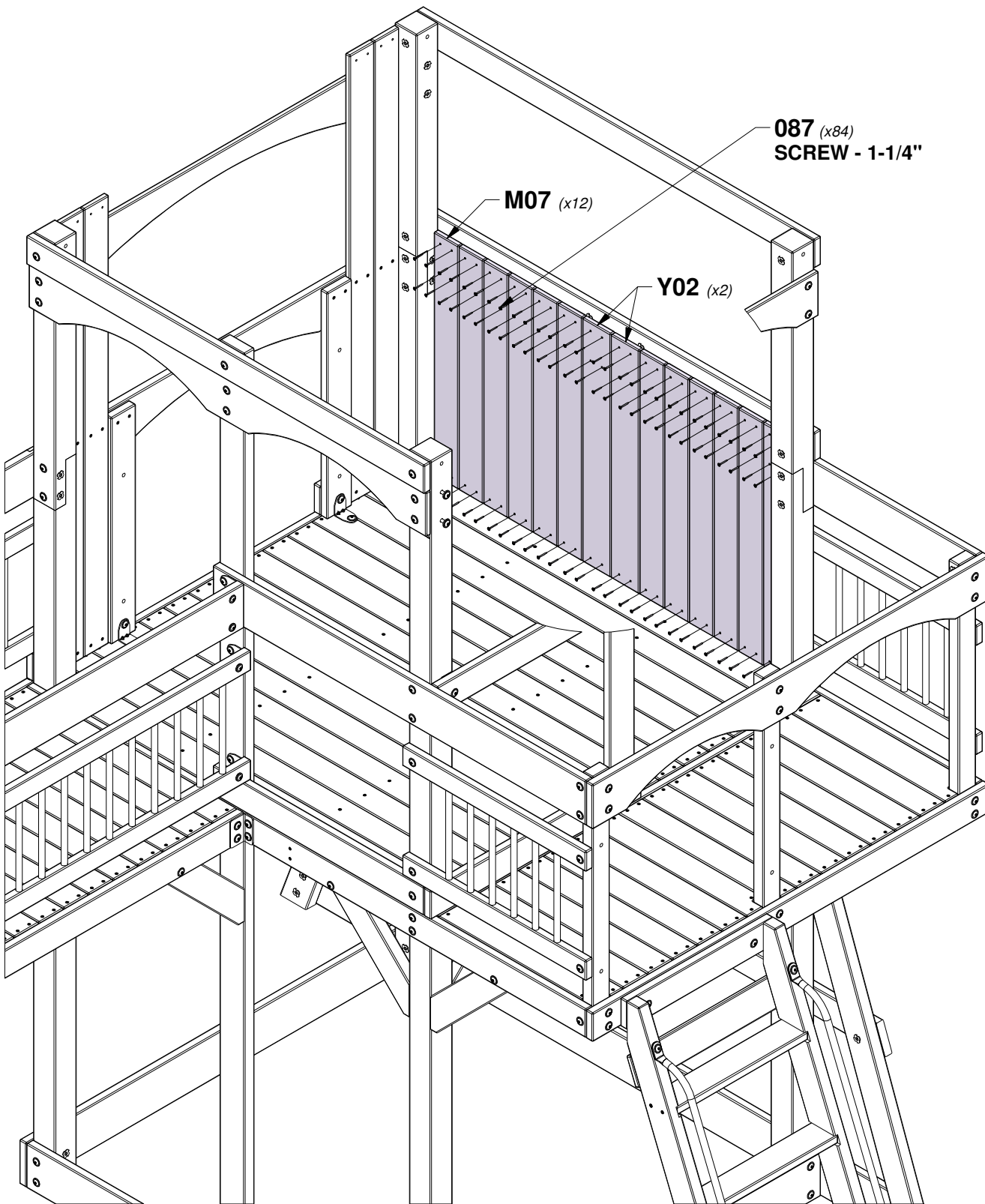

STEP 38 - FORT ASSEMBLY



Y01 WALL BOARD - W4L16693
(x6) 5/8"x3 5/8"x26 7/8" (16x91x684)

QTY	PART NUMBER	DESCRIPTION
24	H100087	SCREW PFH 8x1-1/4"

TIP:
EVENLY SPACE WALL BOARDS

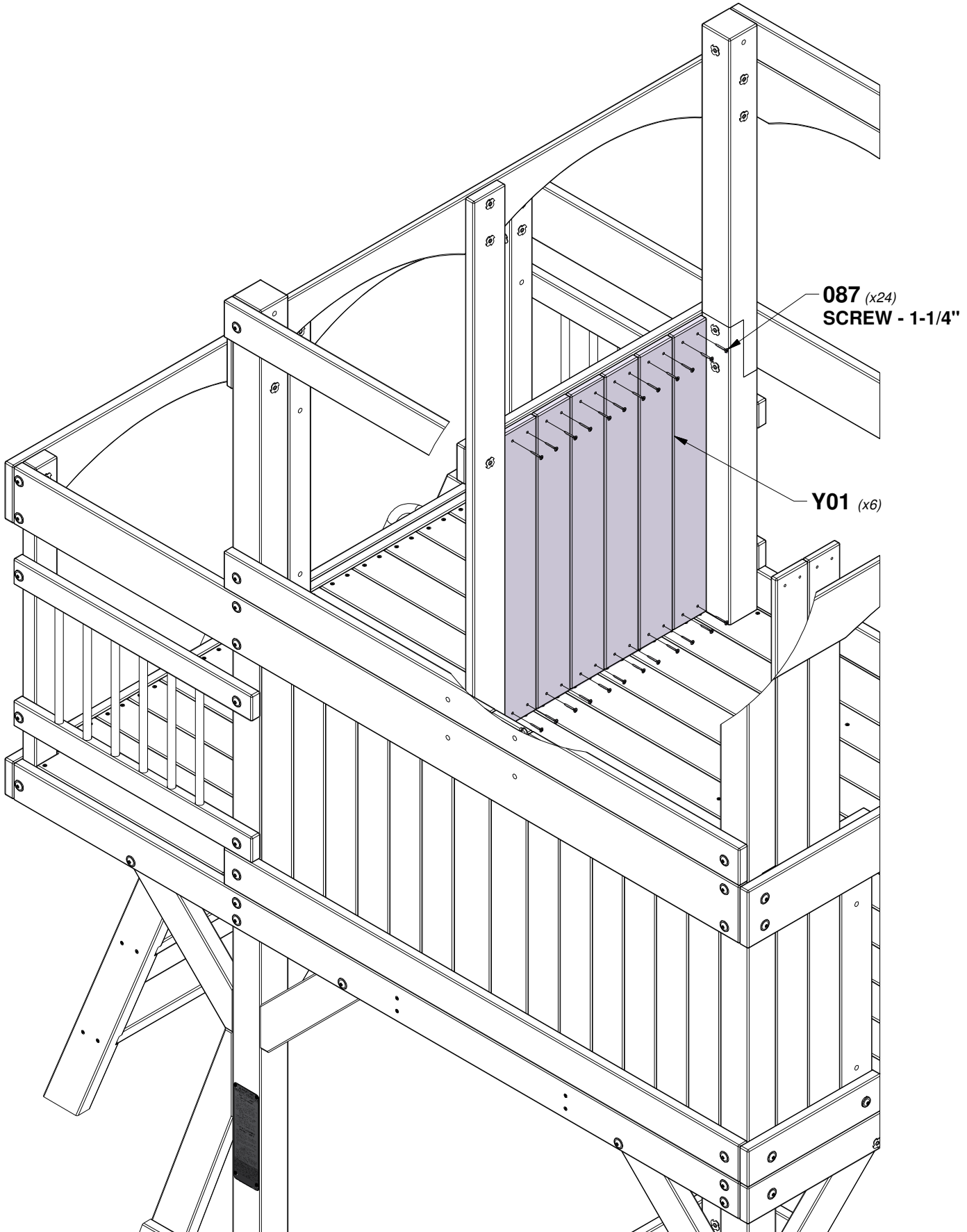

STEP 39 - FORT ASSEMBLY

QTY	PART NUMBER	DESCRIPTION
28	H100087	SCREW PFH 8x1-1/4"



M08 WALL BOARD - W4L16654
(x7) 5/8"x3 1/4"x26 7/8" (16x82x684)

TIP:
EVENLY SPACE WALL BOARDS

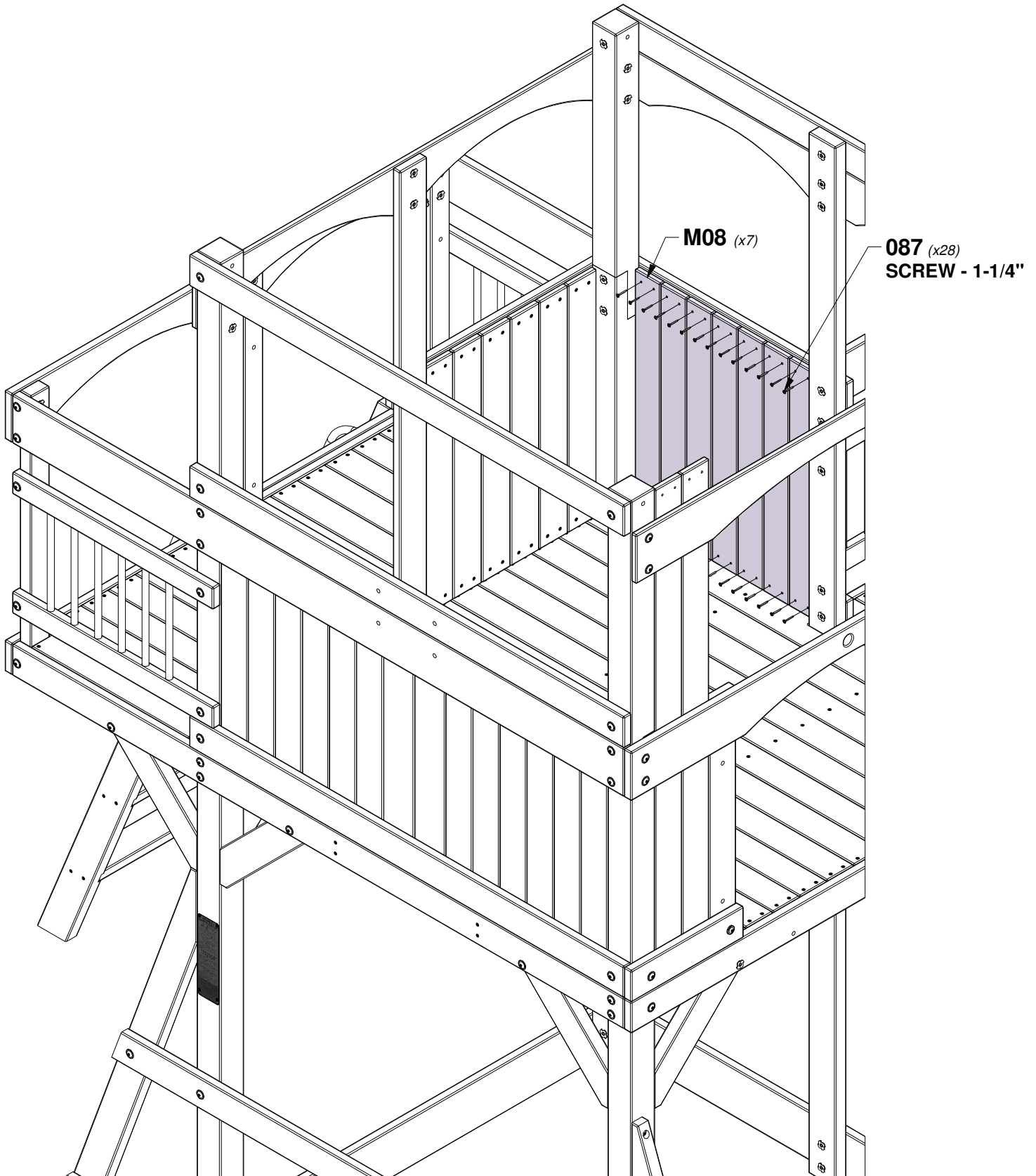

STEP 40 - FORT ASSEMBLY

QTY	PART NUMBER	DESCRIPTION
8	H100087	SCREW PFH 8x1 1/4
4	H100198	WASHER LOCK EXT 8x19 BLK
4	H100379	T-NUT 5/16 BLK
4	H100480	BOLT WH 5/16x4 3/4 BLK

H18 WALL RAIL - W4L16681
(x2) 1"x3 3/8"x54" (24x86x1372)

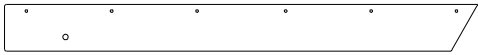

H19 ROOF RAIL - W4L16682
(x4) 1"x3 3/8"x34 1/2" (24x86x877)

HOLES UPWARD

TIP:
INSTALL T-NUTS IN WOOD FIRST

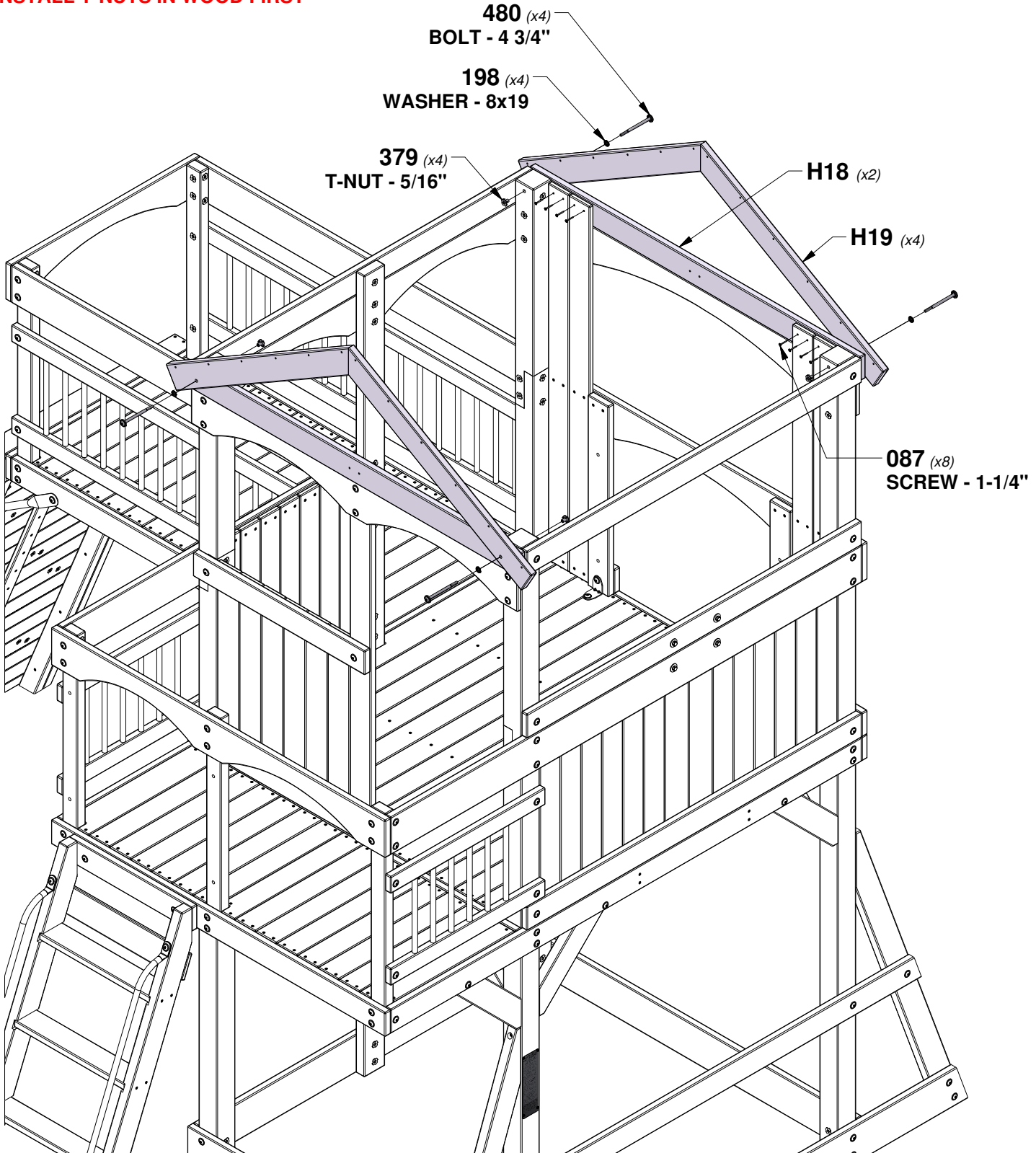

STEP 41 - FORT ASSEMBLY

QTY	PART NUMBER	DESCRIPTION
24	H100087	SCREW PFH 8x1-1/4"
12	H100089	SCREW PFH 8x1-3/4"



H20 GABLE BOARD - W4L16683
 (x2) 1"x3 3/8"x15 5/8" (24x86x397)



H21 GABLE CLEAT - W4L16684
 (x2) 1"x3"x3 3/8" (24x76x86)



M15 GABLE BOARD - W4L16685
 (x4) 5/8"x3 3/8"x18 1/4" (16x86x465)



M16 GABLE BOARD - W4L16687
 (x4) 5/8"x3 3/8"x11 3/4" (16x86x300)

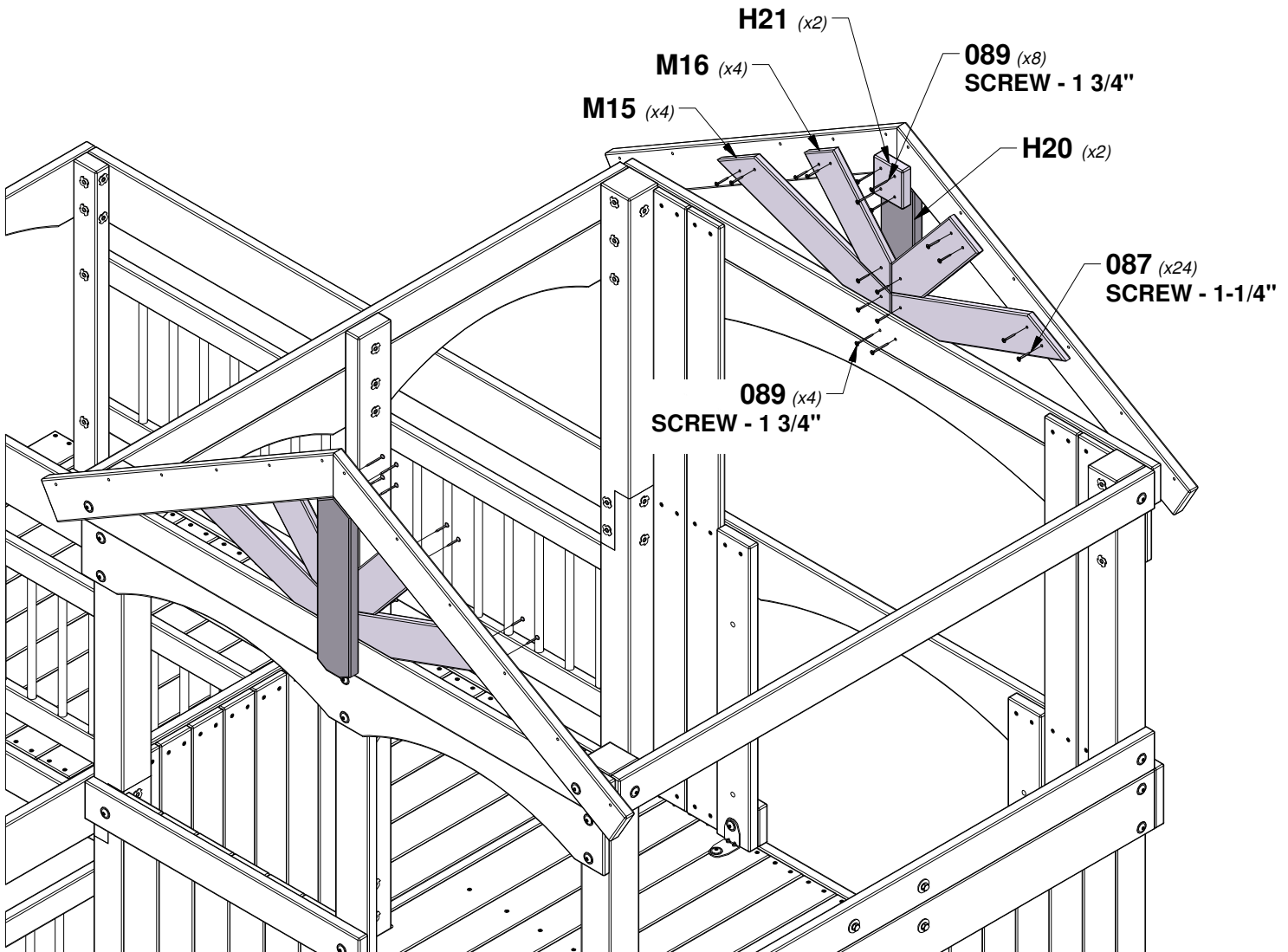
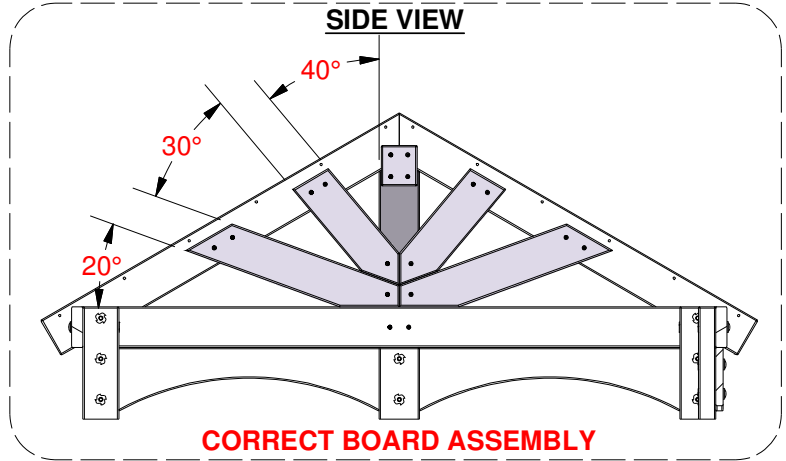

STEP 42 - FORT ASSEMBLY

QTY	PART NUMBER	DESCRIPTION
12	H100111	SCREW PFH 8x2

.	.
.	.
.	.
.	.
.	.
.	.

RP1 PEAK ROOF PANEL - W2A03428
 (x2) 1 5/8"x15"x59 1/8" (42x382x1613)

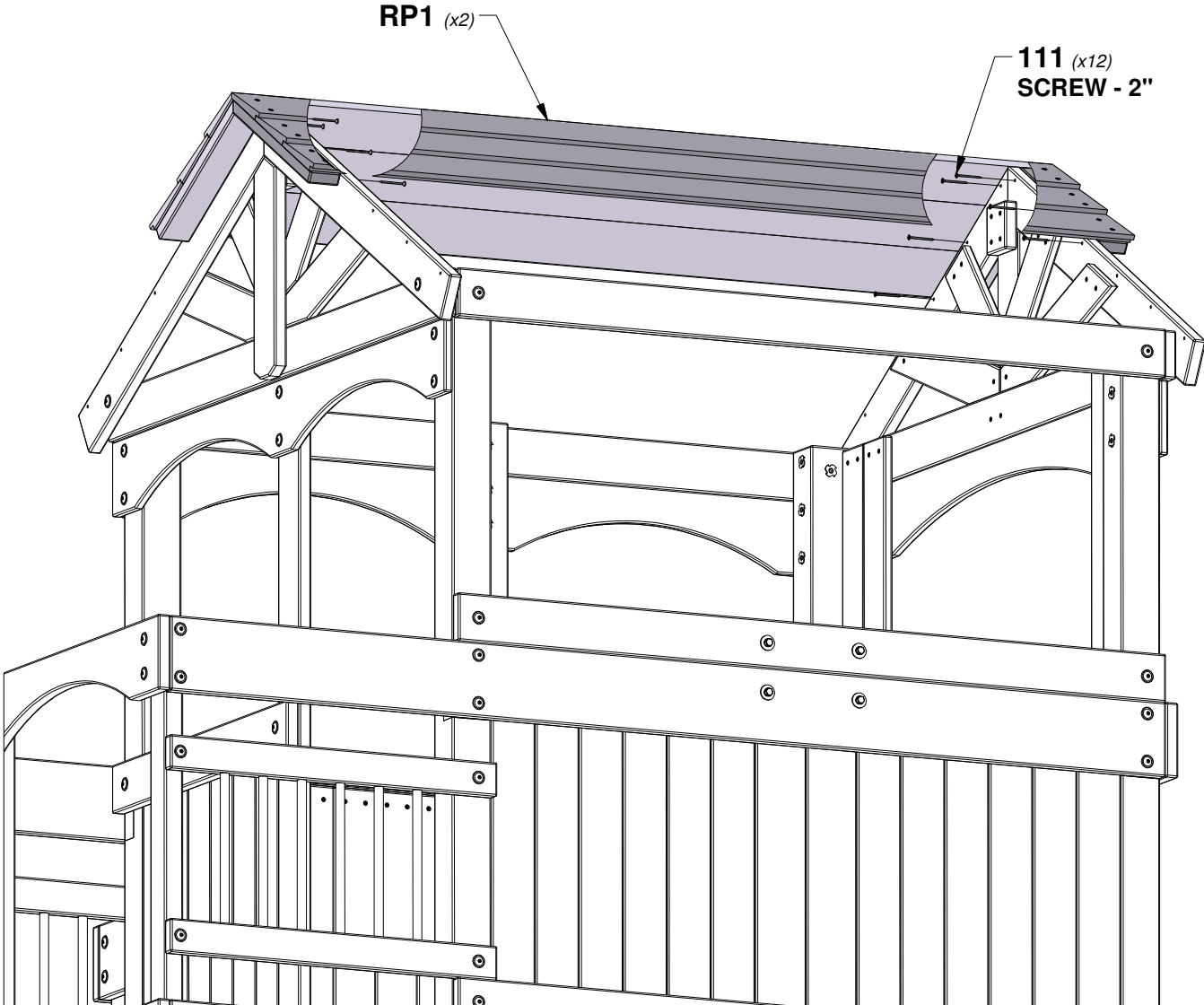
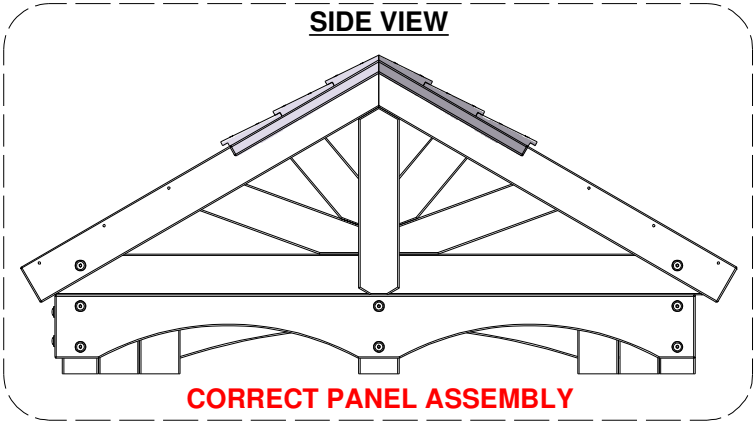

STEP 43 - FORT ASSEMBLY

QTY	PART NUMBER	DESCRIPTION
12	H100111	SCREW PFH 8x2

.	.
.	.
.	.
.	.
.	.
.	.
.	.
.	.

RP2 ROOF PANEL - W2A03429
 (x2) 1 5/8"x20 5/8"x66" (42x524x1613)

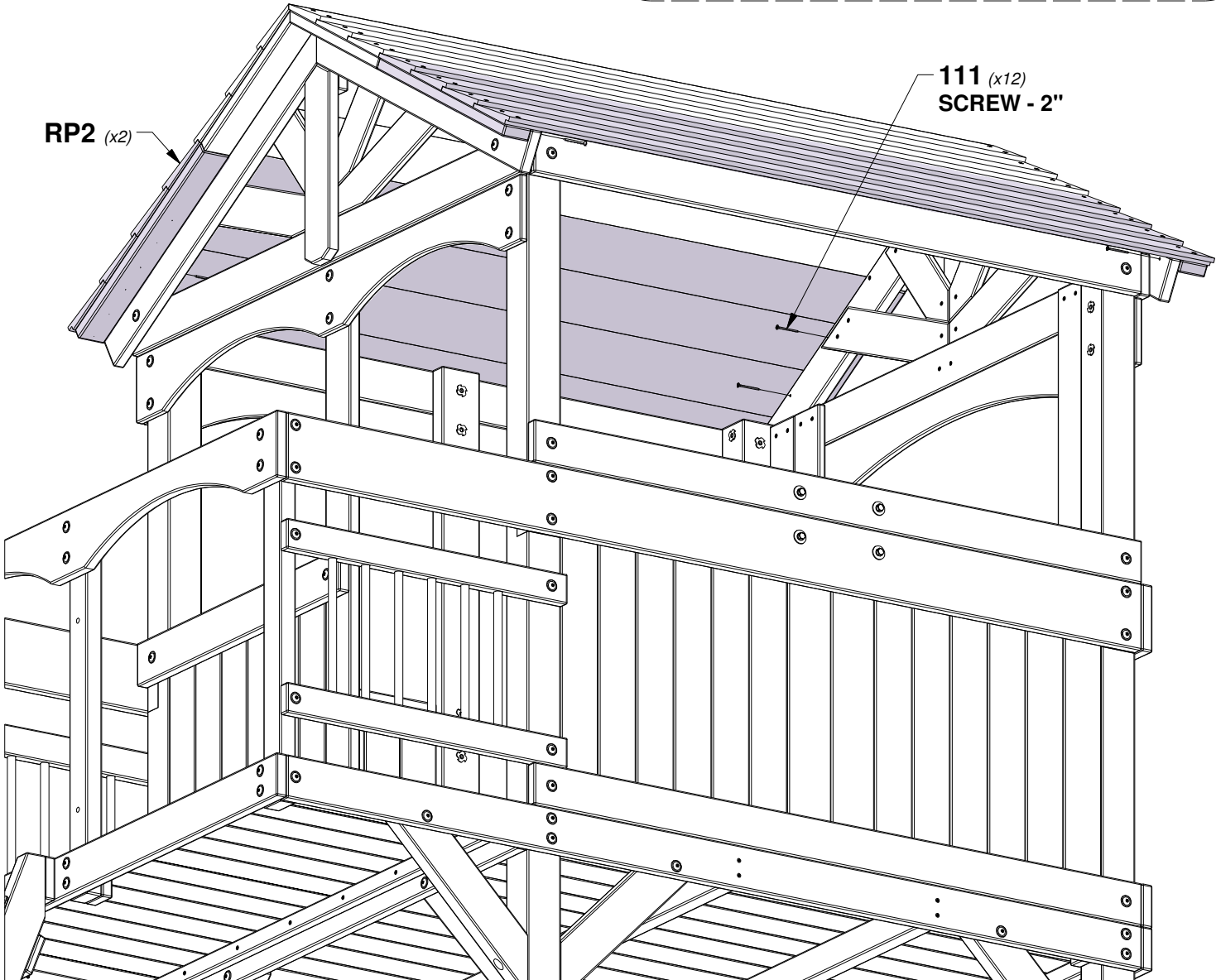
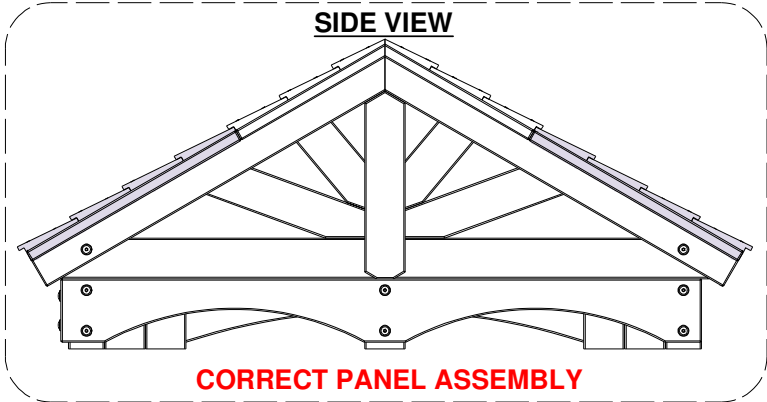

STEP 44 - FORT ASSEMBLY

QTY	PART NUMBER	DESCRIPTION
24	H100385	SCREW PFH 8x1 BLK



N02 ROOF CLEAT - W4L16686
(x4) 5/8"x2 3/8"x26 5/8" (16x60x675)

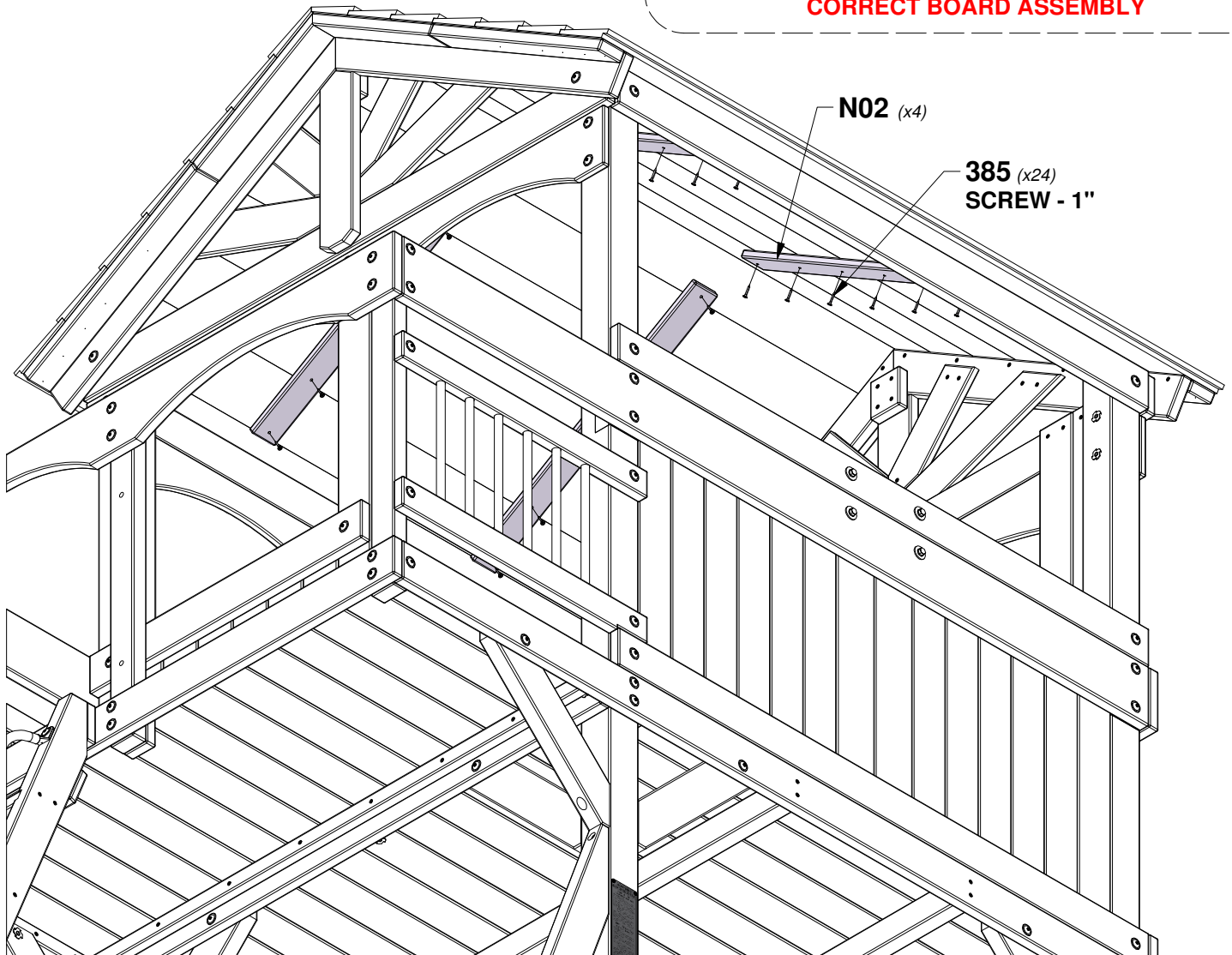
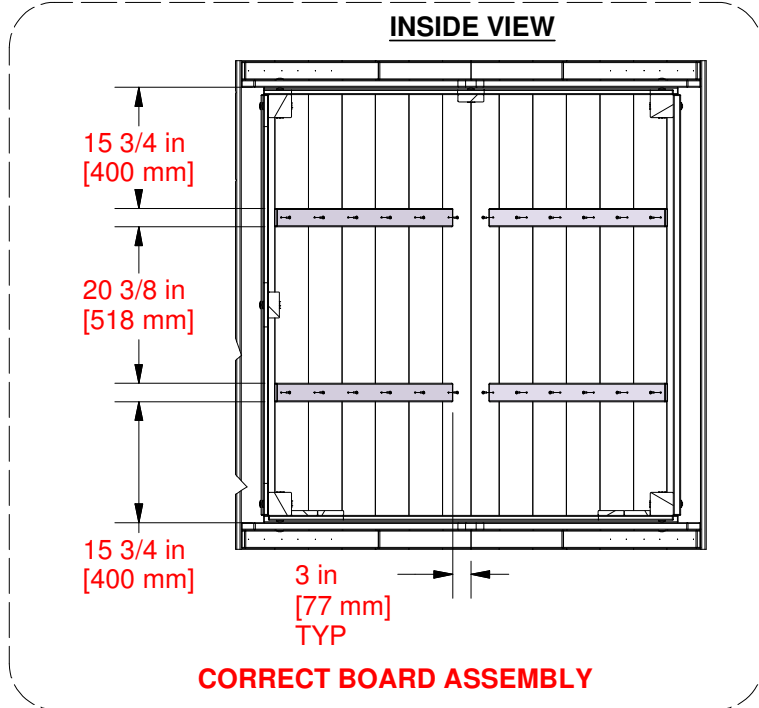

STEP 45 - FORT ASSEMBLY

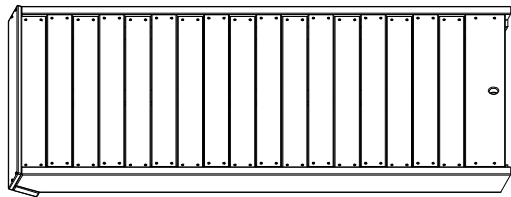

ROPE WALL ASSEMBLY

QTY	PART NUMBER	DESCRIPTION
2	H100198	WASHER LOCK EXT 8x19 BLK
2	H100457	BOLT WH 5/16x2 BLK

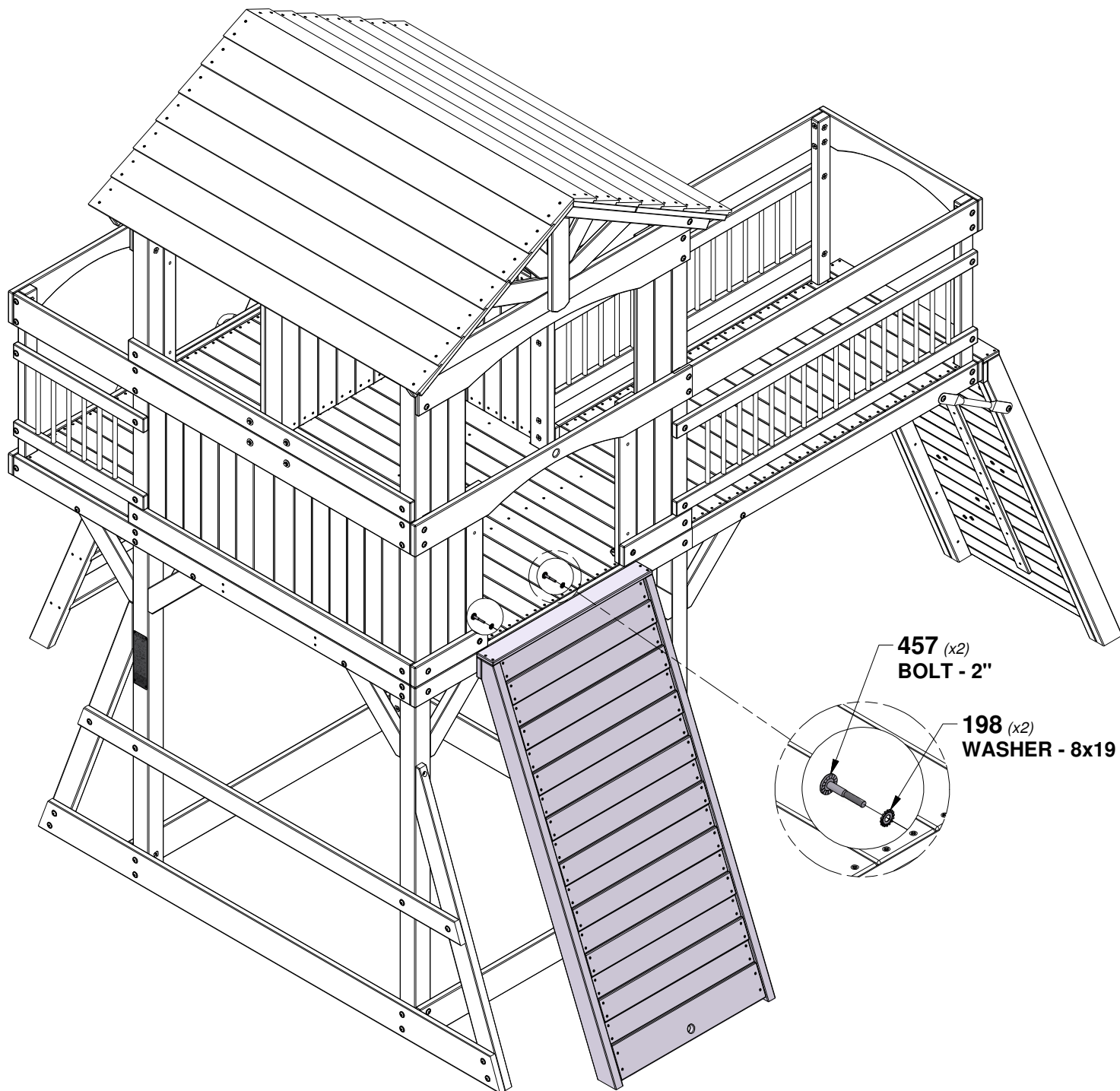

STEP 46 - FORT ASSEMBLY

QTY	PART NUMBER	DESCRIPTION
4	H100379	T-NUT 5/16 BLK
4	H100468	BOLT WH 5/16x1 BLK

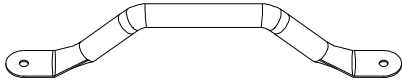

A4M00613
(x2) **HAND GRIP METAL BLACK 381 c/c**

TIP:
INSTALL T-NUTS IN WOOD FIRST

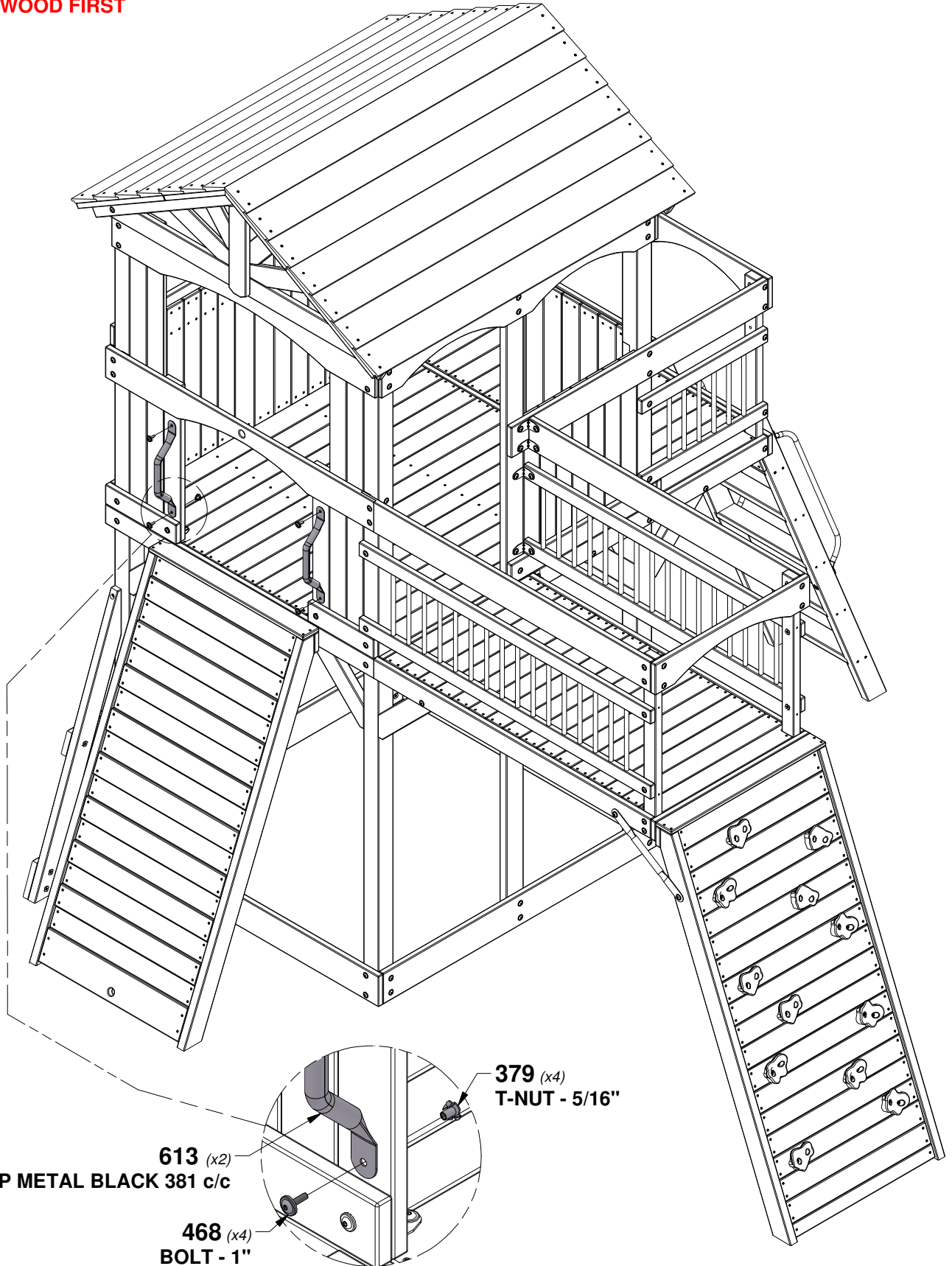

613 (x2)

HAND GRIP METAL BLACK 381 c/c

468 (x4)
BOLT - 1"

379 (x4)
T-NUT - 5/16"

STEP 47 - FORT ASSEMBLY

QTY	PART NUMBER	DESCRIPTION
4	H100458	LAG SCREW WH 5/16x2 BLK

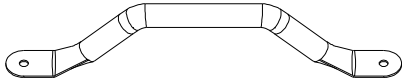

A4M00613
(x2) **HAND GRIP METAL BLACK 381 c/c**

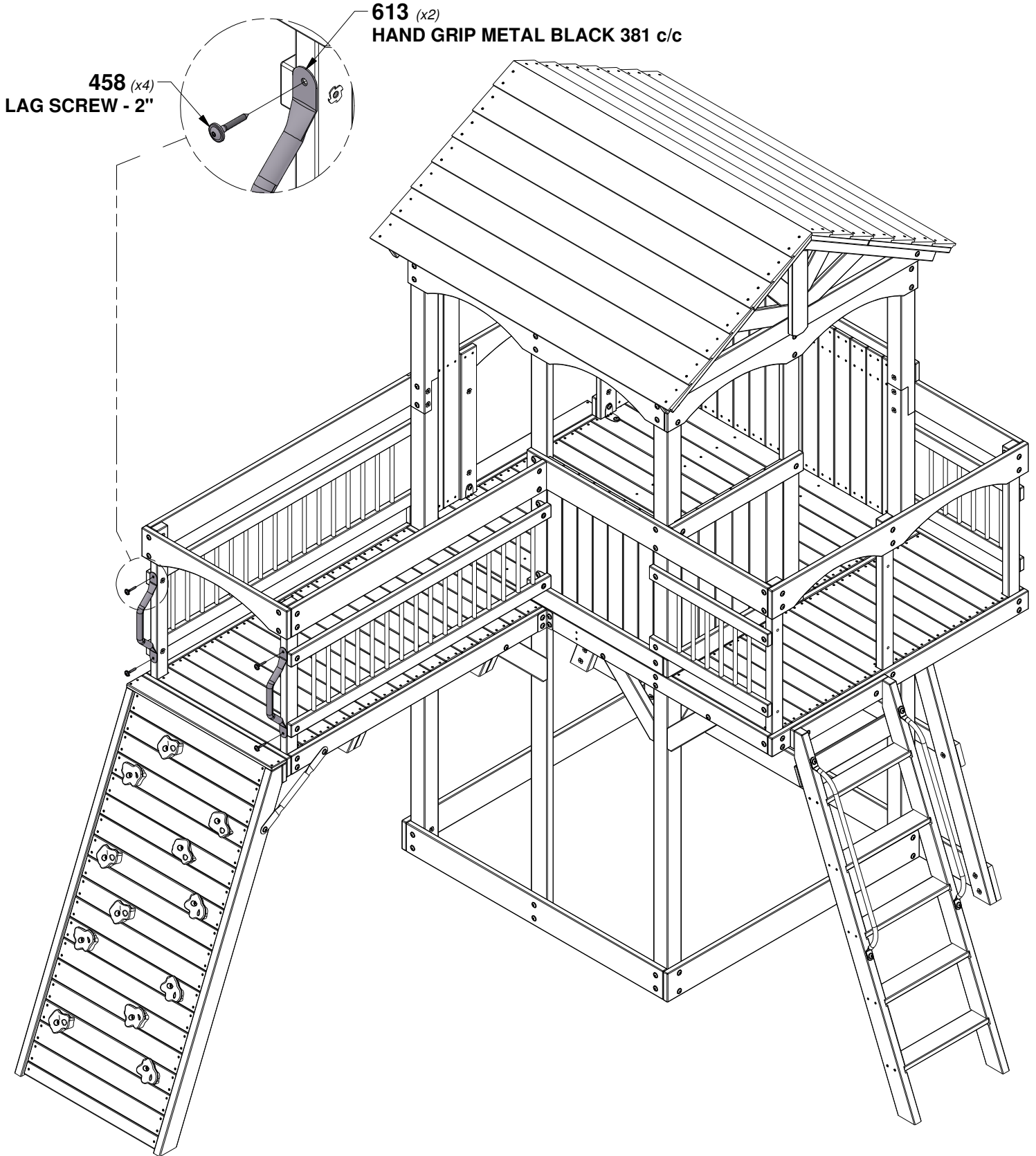

STEP 48 - FORT ASSEMBLY

QTY	PART NUMBER	DESCRIPTION
4	H100379	T-NUT 5/16 BLK
4	H100407	BOLT WH 5/16x1 1/2 BLK

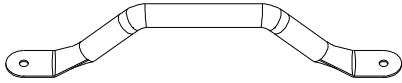

A4M00613
(x2) **HAND GRIP METAL BLACK 381 c/c**

TIP:
INSTALL T-NUTS IN WOOD FIRST

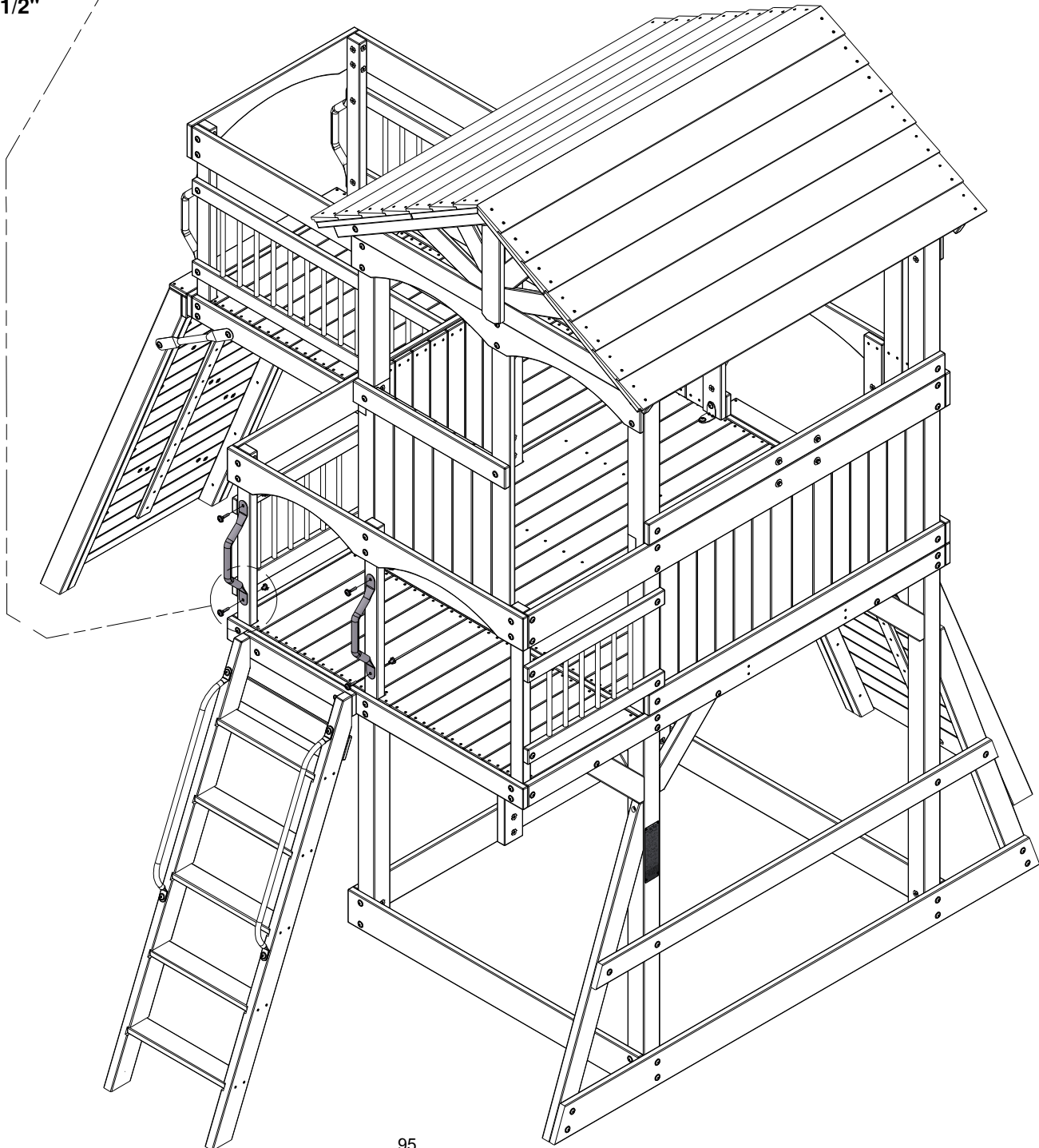
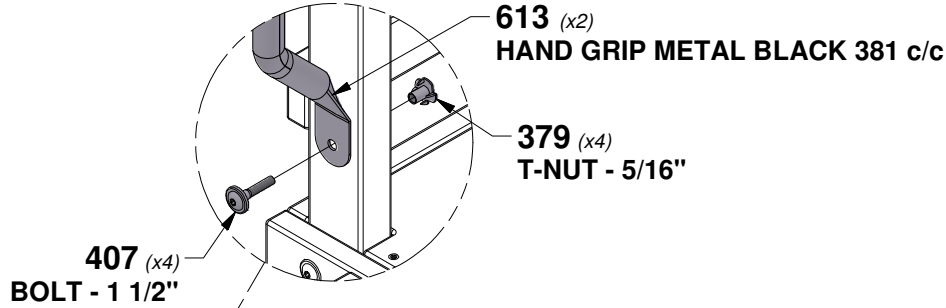

STEP 1 - ROPE CLAMP ASSEMBLY

ROPE CLAMP ATTACHED IN NEXT STEP.

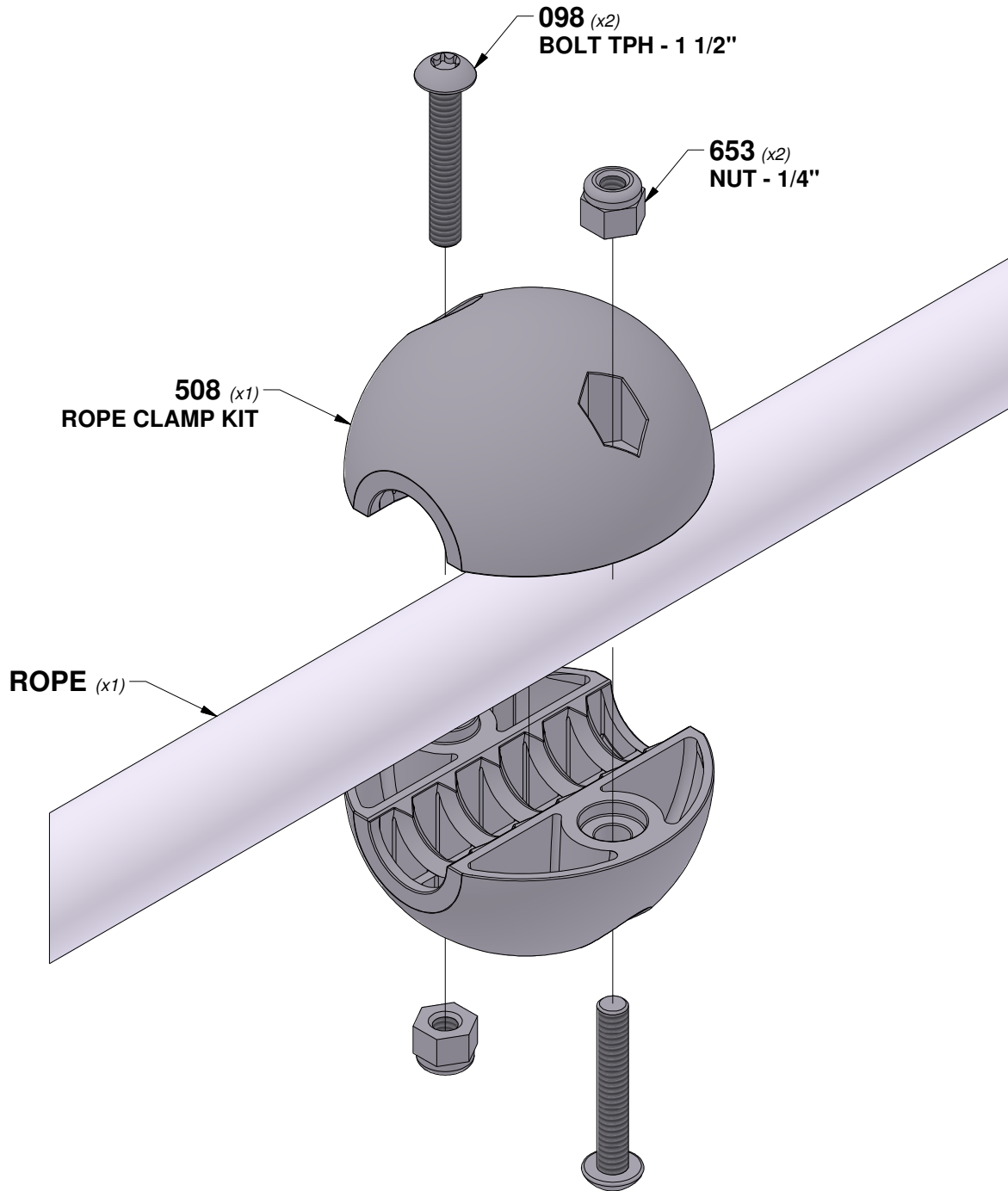

STEP 49 - FORT ASSEMBLY



A6P00508 | ROPE CLAMP KIT
(x7)

A6P00520 | ROPE
(x1)

**MINIMUM 2 INCHES [50mm] OF
ROPE OUT OF ROPE CLAMP**

508 (x7)
ROPE CLAMP KIT

520 (x1)
ROPE

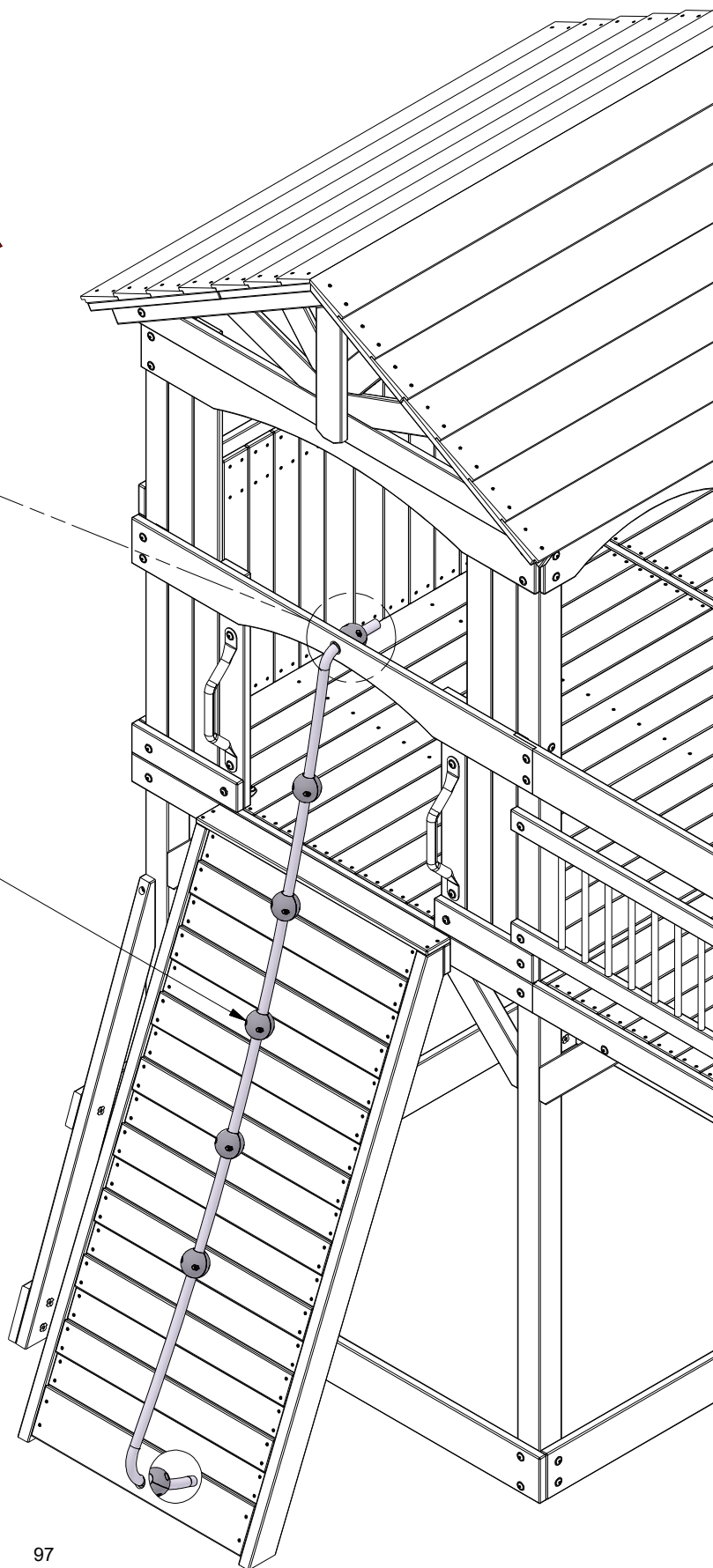
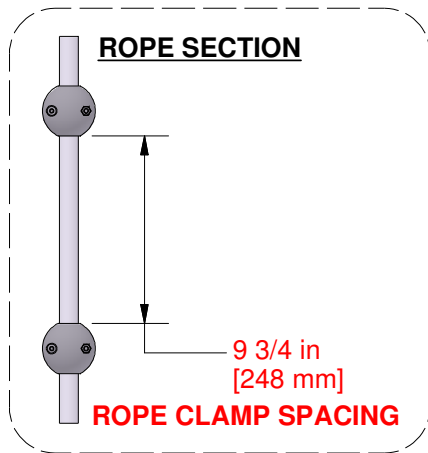
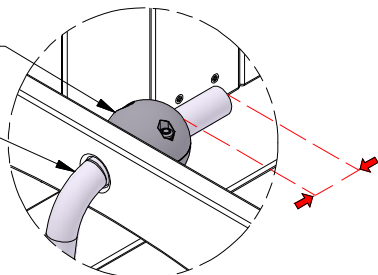

STEP 1 - WEB SWING ASSEMBLY

QTY	PART NUMBER	DESCRIPTION
4	H101121	BOLT PTH 1/4x1 BLK with LOCTITE
4	H100831	NUT BARREL PTH 1/4x3/4 BLK

WEB SWING SETUP INSTRUCTIONS

FOLLOW INSTRUCTIONS BELOW BEFORE USING THE WEB SWING.

IMPORTANT:
SLIDE ROPE LOOPS OVER TUBE ENDS FIRST!
(SEE VIEW BELOW)

SLIDE NARROW END OF TUBES INTO LARGER OPENING **AFTER** SLIDING ROPE LOOPS ONTO TUBES.

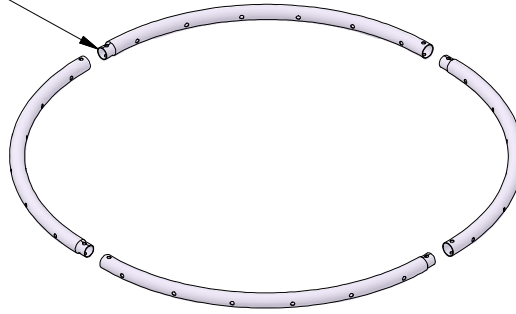

NOTE: ROPE WEBBING NOT SHOWN IN ILLUSTRATION FOR CLARITY.

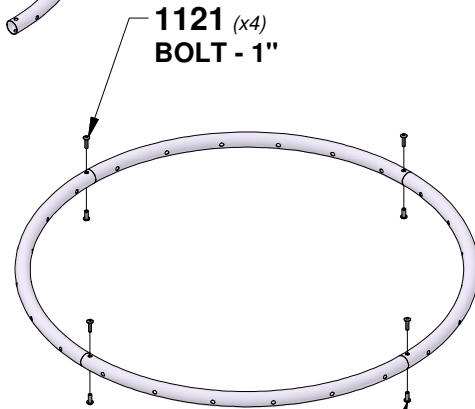

1121 (x4)
BOLT - 1"

831 (x4)
NUT BARREL - 3/4"

NOTE: IT IS IMPORTANT THAT THE WEB SWING HANG LEVEL.

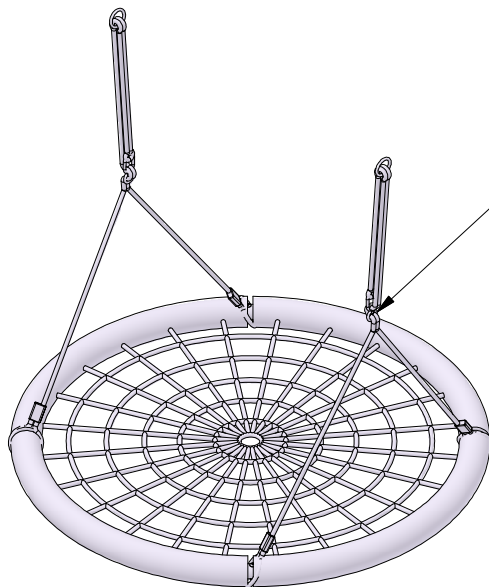

TO ENSURE WEB SEAT IS LEVEL,
ADJUST BOTH "S" BRACKETS UNTIL LEVEL.

ROPE LOOPS

SWING MUST BE SET AT A MINIMUM OF 13 7/8 INCHES OFF THE GROUND WHEN INSTALLED.

STEP 50 - FORT ASSEMBLY

A4M01495 (x1) | 40" WEB SWING

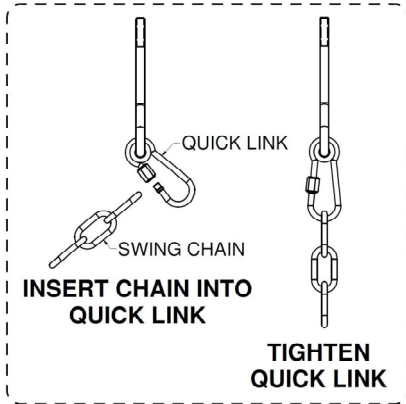
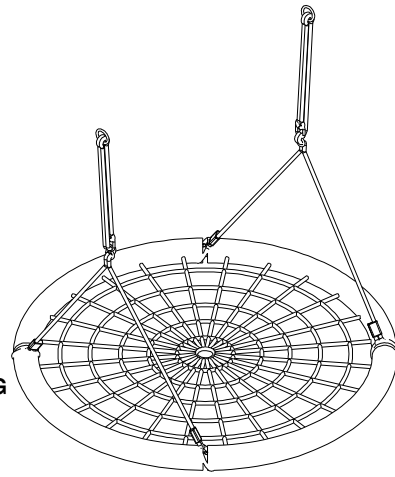

NOTE: WHEN HANGING YOUR SWINGS IT IS RECOMMENDED THAT THE BOTTOM OF THE SWING SEAT, WHEN SITTING ON IT, IS LOCATED NO LOWER THAN (35 cm) 13 7/8 INCHES FROM THE GROUND.

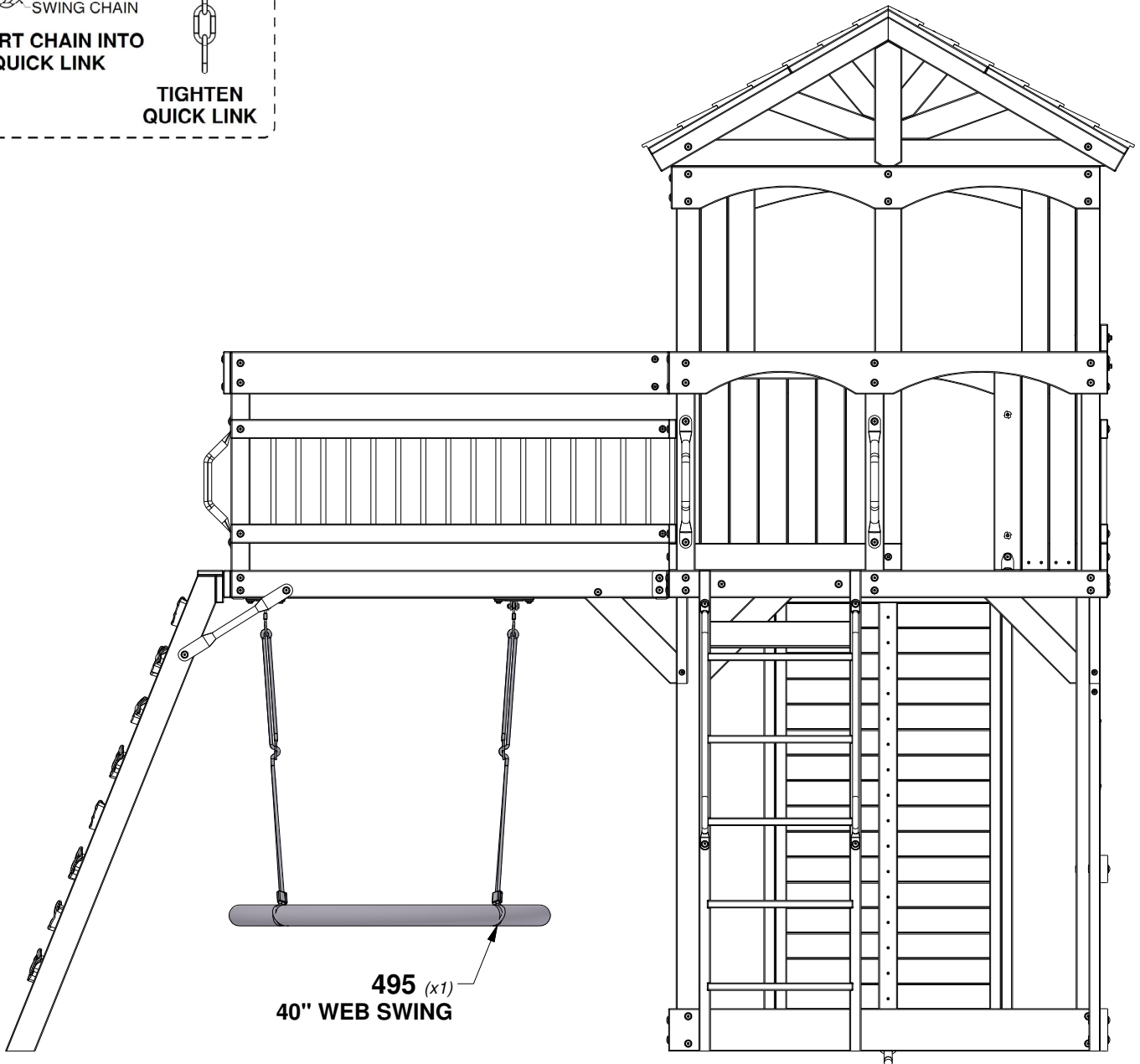

STEP 51 - FORT ASSEMBLY

QTY	PART NUMBER	DESCRIPTION
3	H100074	T-NUT 5/16
3	H100115	BOLT WH 5/16x1/2

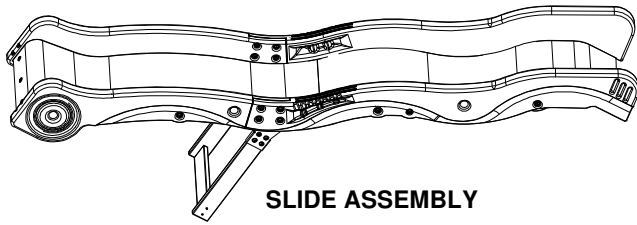

SLIDE ASSEMBLY

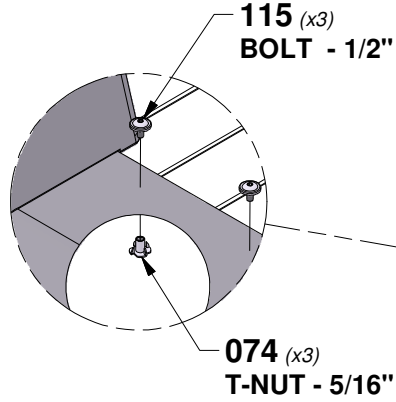
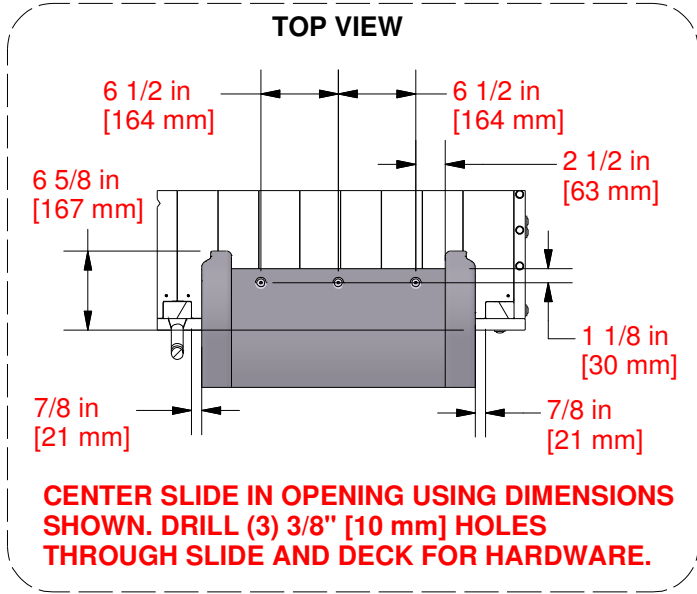

SLIDE ASSEMBLY

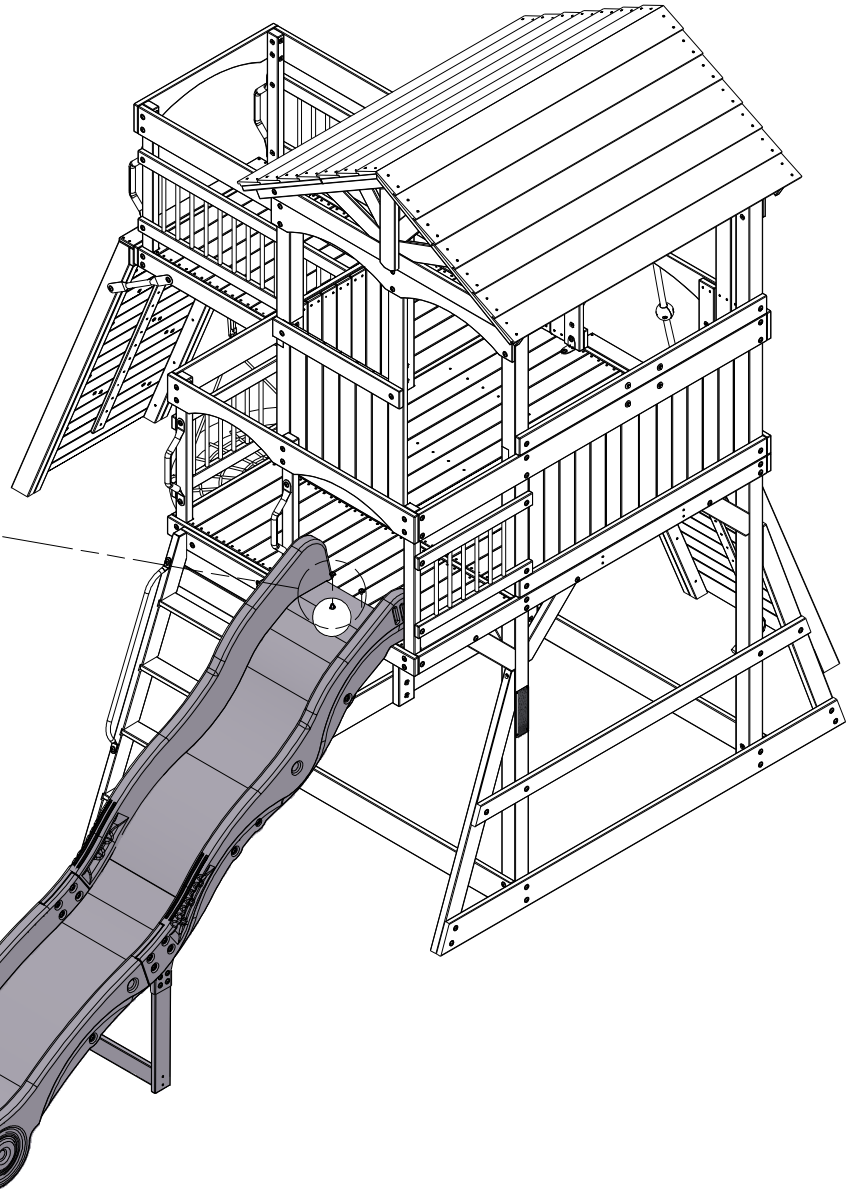

STEP 52 - FORT ASSEMBLY

QTY	PART NUMBER	DESCRIPTION
4	H100477	WASHER SPLIT 5/16 BLK
4	H100478	WASHER FLAT 8x27 BLK
4	H100481	BOLT HEX 5/16x1 1/4 BLK

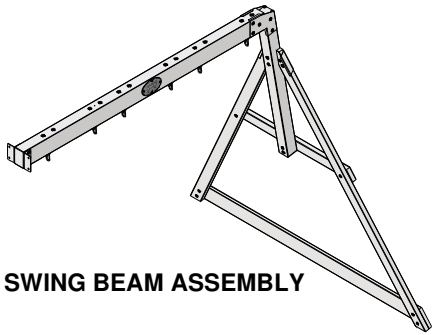

SWING BEAM ASSEMBLY

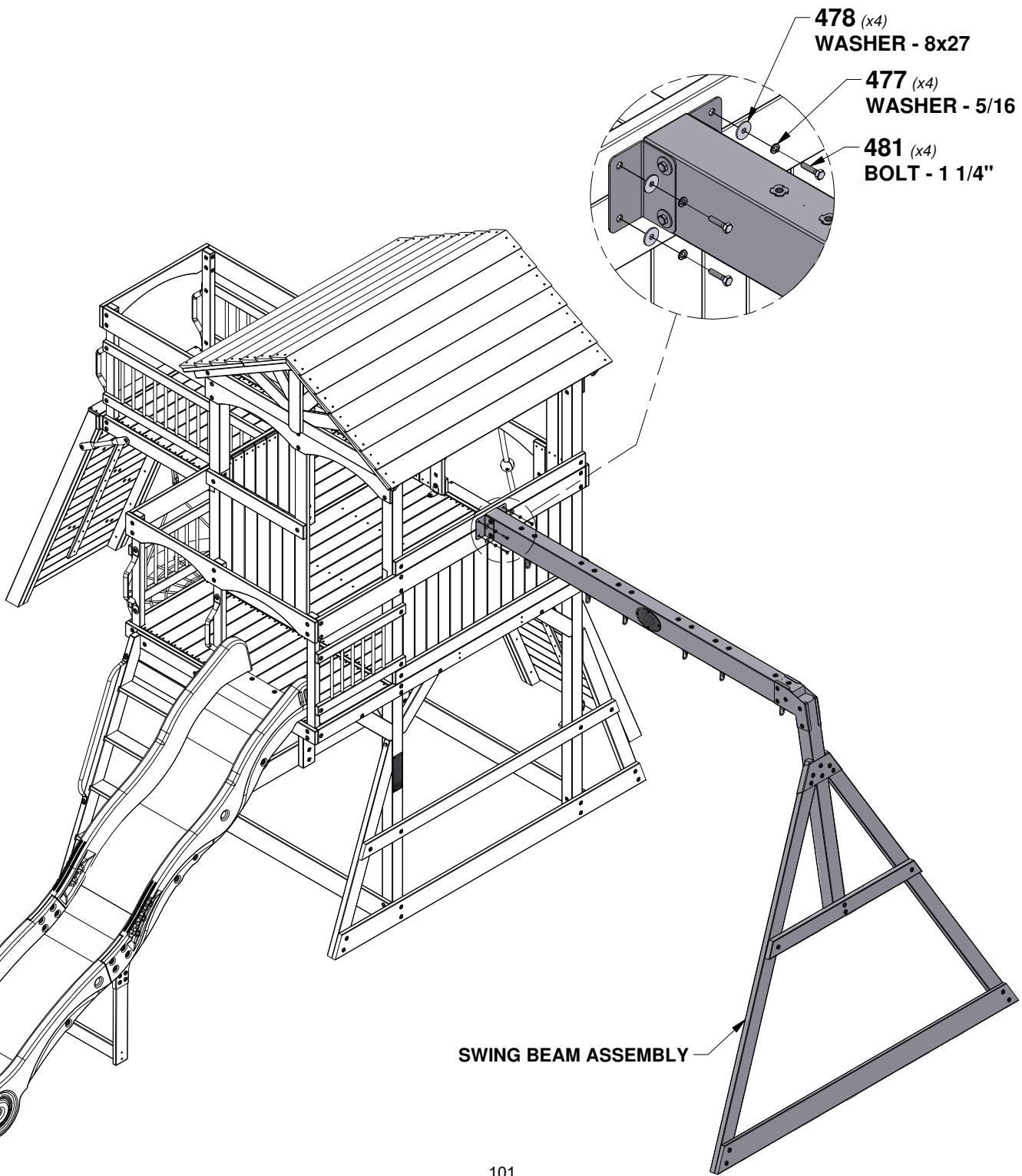

478 (x4)
WASHER - 8x27

477 (x4)
WASHER - 5/16

481 (x4)
BOLT - 1 1/4"

SWING BEAM ASSEMBLY

STEP 53 - FORT ASSEMBLY



A100183
(x4) **ROPE-CHAIN GREEN 57"**

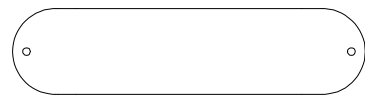

A6P00054
(x2) **SWING SEAT GREEN 22"**



A100083
(x2) **ROPE-CHAIN GREEN 33"**



A100069
(x6) **QUICK LINK**

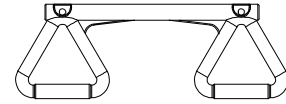

A6P00034
(x1) **TRAPEZE YELLOW**

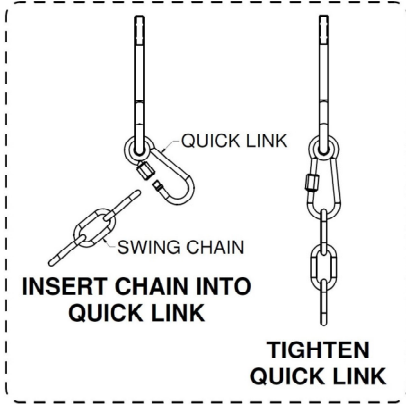

NOTE:
WHEN HANGING YOUR SWINGS, IT IS REQUIRED TO ONLY TRIM AROUND THE SPECIFIC CHAIN LOOP THAT ALLOWS THE BOTTOM OF THE SWING SEAT, WHEN SITTING ON IT, TO BE NO LOWER THAN (35 cm) 13 7/8 INCHES FROM THE GROUND.

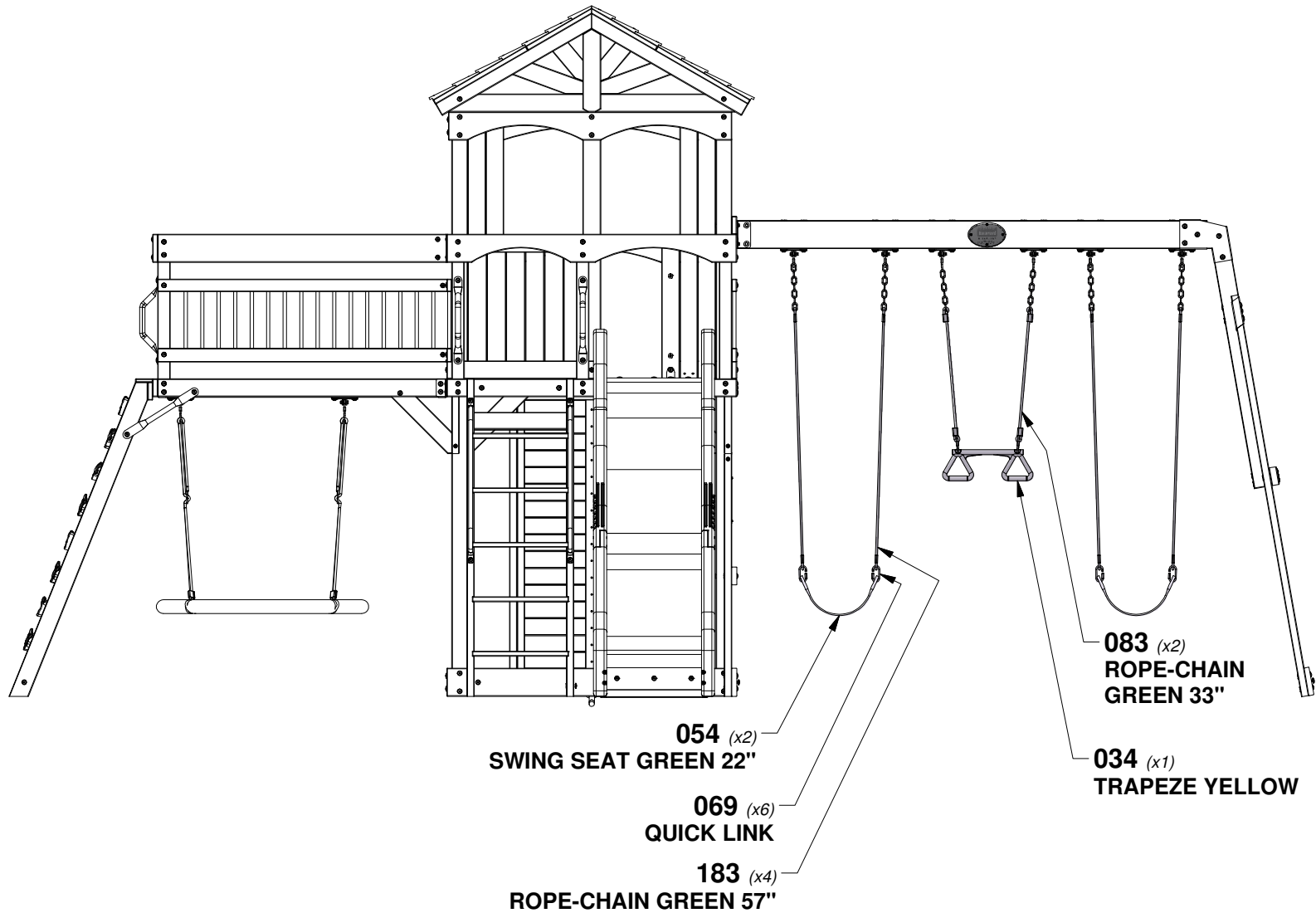

STEP 54 - FORT ASSEMBLY

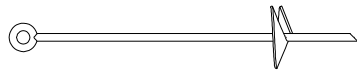

A100178
(x10) **AUGER GROUND STAKE**

QTY	PART NUMBER	DESCRIPTION
3	H100197	LAG SCREW WH 5/16x2-1/2 BLK
1	H100378	BOLT WH 5/16x1 3/4 BLK
7	H100379	T-NUT 5/16 BLK
6	H100459	BOLT WH 5/16x1 1/4 BLK

DETAIL (A)

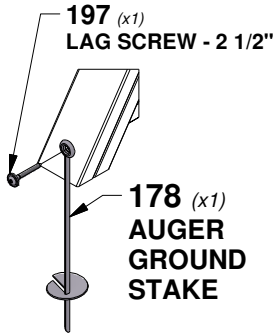

DETAIL (A)
TWIST GROUND STAKE INTO GROUND WHERE SHOWN.
USING GROUND STAKE AS A GUIDE, DRILL (1) 1/4" [6 mm] PILOT HOLE FOR HARDWARE.

DETAIL (C)

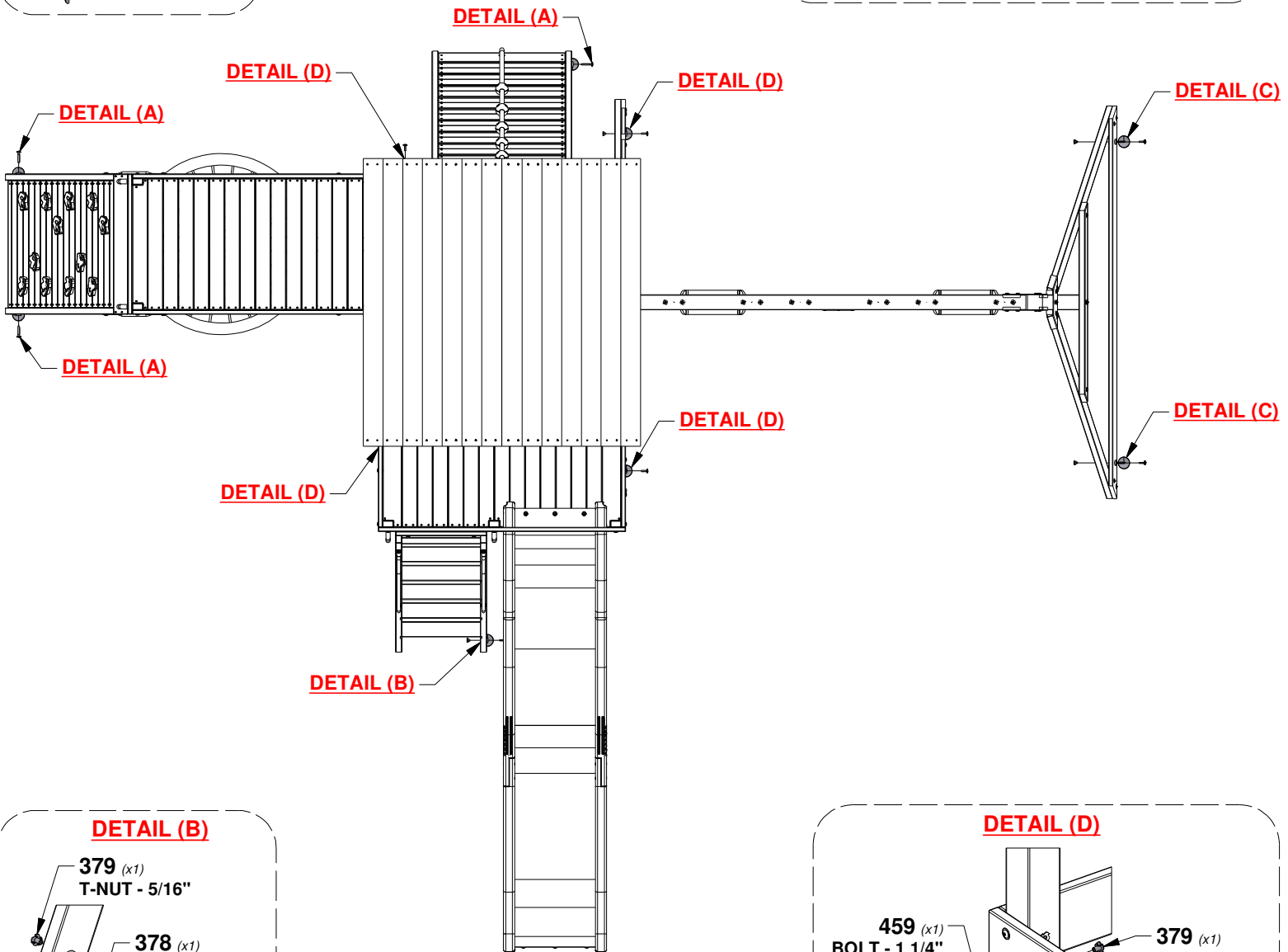
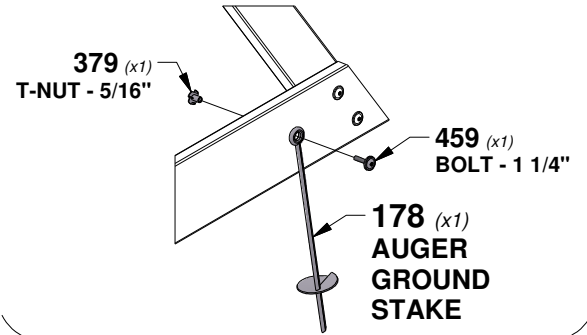

DETAIL (B)

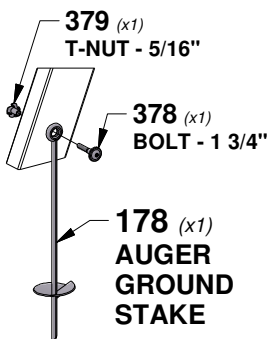

DETAIL (B), (C), & (D)
TWIST GROUND STAKE INTO GROUND WHERE SHOWN.
USING GROUND STAKE AS A GUIDE, DRILL (1) 3/8" [10 mm] HOLE FOR HARDWARE.

DETAIL (D)

