



MANUFACTURED BY:
Backyard Discovery
3305 Airport Drive, Pittsburg, KS 66762
800-856-4445

Basepoint Business Centre: Rivermead Drive, Westlea, Swindon SN5 7EX Phone: 0800-118-2476
J.P. Coenstraat 7, The Bridge, The Hague, 2595 WP, Netherlands Phone: 0800-567-8990

MONTPELIER

Swing Set

Model # 30211G, 2400047

The assembly manual must be retained
since it contains important information



WARNING

Adult Assembly Required.

Not suitable for children under 36 months due to small parts.

FOR DOMESTIC USE ONLY. INTENDED FOR OUTDOOR USE.



Please visit www.backyarddiscovery.com

For the most up to date assembly manual, to register your set, or to order replacement parts

Para obtener instrucciones en español, visite www.backyarddiscovery.com



EASY STEP-BY-STEP
3D INTERACTIVE INSTRUCTIONS

DOWNLOAD THE FREE APP



Made in China

INS-30211G, 2400047-A-MONTPELIER EN-71-ENG 10-25-23

Owner's Manual - Basic Setup Dimensions & Assembly Notes

Place the set on level ground, not less than 6'-7" [2 m] from any structure or obstruction such as a fence, garage, house, overhanging branches, laundry lines, or electrical wires.

- While assembling unit, take time before and after each phase to make sure fort is level. If fort is not level, assembly will be difficult and improper assembly may result. Extra care must be taken to insure the fort is square.
- The safe play area refers to a zone extending 6'-7" (2 m) beyond the play product on all sides, including the space above the play product.

SAFE PLAY AREA DIAGRAM

Ground Dimensions

16'-1" [4.9] x 15'-5 3/4" [4.7] x 9'-4 1/4" [2.8]

Safe Play Area

29'-3" [8.9] x 28'-7 3/4" [8.7] x 15'-11 1/4" [4.9]

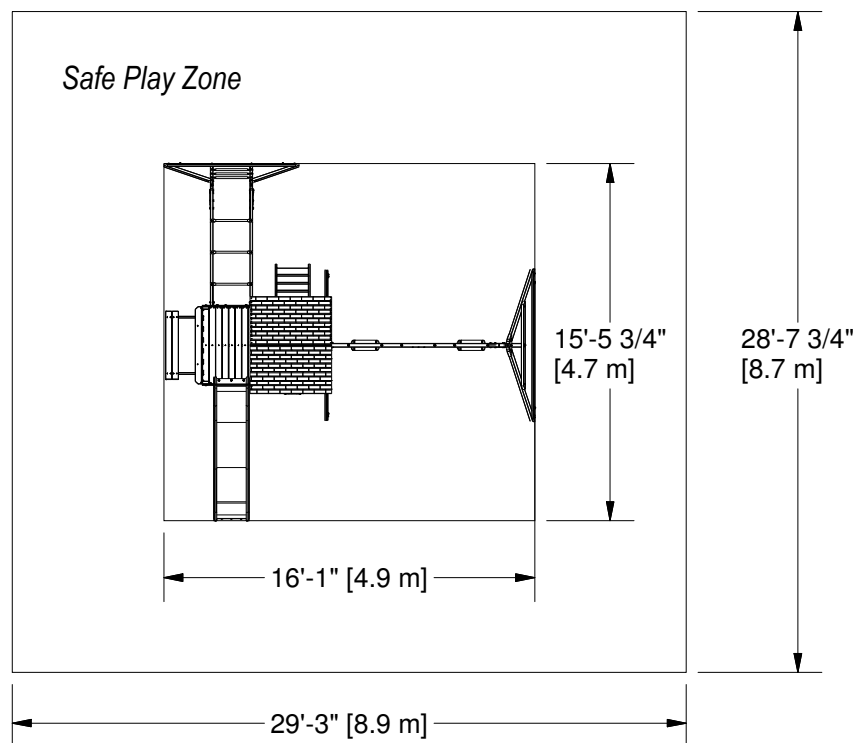

SAFE PLAY HEIGHT: 15'-11 1/4" [4.9 m]
 MAXIMUM FALL HEIGHT: 6' 3" [1.9 m]

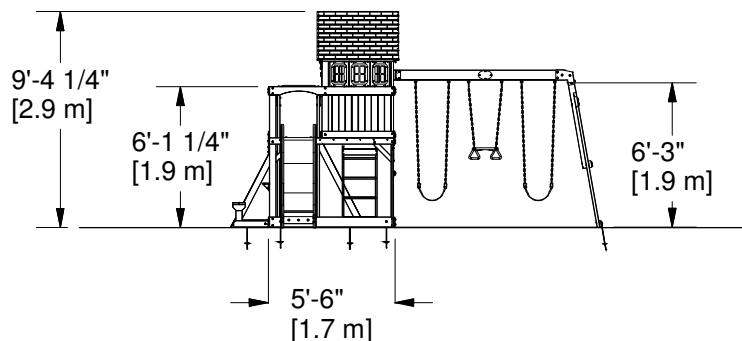

General Information:

Your set has been designed and engineered for children only and for residential use only.
 A maximum of 150 lbs. per child is recommended for play activities designed for individual use.
 A maximum of 120 lbs. per child is recommended for play activities designed for multiple child use.
 A maximum of 9 children is recommended for this swing set.

Owner's Manual - Parts Identification

Wood Components (Not to Scale)



E1 | UPRIGHT - W2A03132
(x1) | 1 3/8"x3 3/8"x89 1/2" (36x86x2274)



E2 | UPRIGHT - W4L14532
(x1) | 1 3/8"x3 3/8"x73 1/8" (36x86x1856)

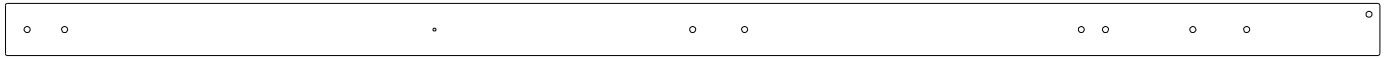

E3 | UPRIGHT - W4L14533
(x1) | 1 3/8"x3 3/8"x89 1/2" (36x86x2274)



E4 | CLUB HOUSE LEG - W4L14534
(x1) | 1 3/8"x3 3/8"x43 1/8" (36x86x1094)

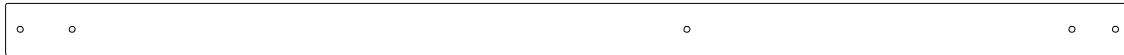

E5 | UPRIGHT - W4L14535
(x1) | 1 3/8"x3 3/8"x73 1/8" (36x86x1856)



E6 | MONKEY BAR UPRIGHT - W4L14536
(x2) | 1 3/8"x3 3/8"x71 3/8" (36x86x1812)

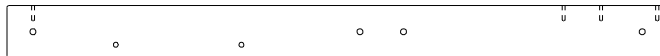

E8 | CLUB HOUSE LEG - W4L14537
(x1) | 1 3/8"x3 3/8"x43 1/8" (36x86x1094)

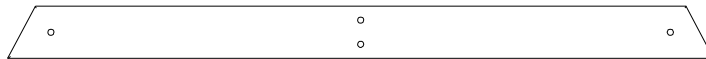

E50 | END SUPPORT - W4L14538
(x1) | 1 1/2"x3 1/2"x46" (36x86x1168)



E71 | MONKEY BAR RAIL - W4L14539
(x2) | 1 3/8"x3 3/8"x60 5/8" (36x86x1539)



E77 | ANGLE BRACE - W4L14540
(x2) | 1 3/8"x3 3/8"x81" (36x86x2056)

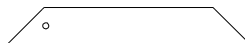

F1 | DECK BRACE - W4L14541
(x6) | 1"x2 3/8"x15 3/4" (24x60x400)

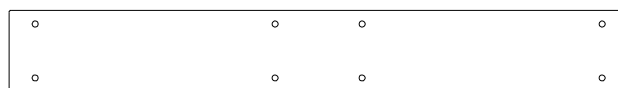

G1 | SWING BEAM MOUNT - W4L14542
(x1) | 1"x5 1/4"x40 3/8" (24x134x1024)



G2 | WALL RAIL - W4L14611
(x2) | 1"x4 3/8"x40 3/4" (24x112x1034)



H1 | TABLE SUPPORT - W4L14543
(x2) | 1"x2"x4" (24x51x102)

Owner's Manual - Parts Identification

Wood Components (Not to Scale)

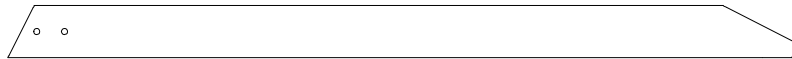

H2 | MONKEY BAR BRACE - W4L14544
(x2) | 1"x3 3/8"x51 1/2" (24x86x1308 mm)



H3 | MONKEY BAR GROUND BOARD - W4L14545
(x1) | 1"x3 3/8"x70 3/8" (24x86x1786)



H6 | ANGLE BRACE - W4L14549
(x2) | 15/16"x3 3/8"x47" (24x86x1194)



H7 | BENCH GROUND BOARD - W4L14546
(x2) | 1"x3 3/8"x18 1/8" (24x86x460)



H8 | BENCH UPRIGHT - W4L14547
(x2) | 1"x3 3/8"x11 3/4" (24x86x300)



H9 | BENCH SEAT SUPPORT - W4L14548
(x2) | 1"x3 3/8"x6 1/2" (24x86x166)



H11 | BENCH SEAT - W4L14555
(x2) | 1"x3 3/8"x35 3/8" (24x86x900)



H74 | LEFT UPRIGHT - W4L17611
(x1) | 1 3/8"x3 3/8"x50 3/4" (36x86x1290)

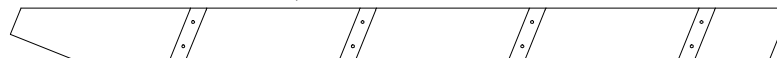

H75 | RIGHT UPRIGHT - W4L17612
(x1) | 1 3/8"x3 3/8"x50 3/4" (36x86x1290)



H80 | GROUND BOARD - W4L14552
(x1) | 1"x3 3/8"x79 1/2" (24x86x2018)



H81 | LADDER RUNG - W4L14554
(x4) | 1"x3 3/8"x17 1/8" (24x86x434)



H82 | ATTACHMENT BOARD - W4L17613
(x1) | 1"x3 3/8"x19 1/8" (24x86x486)

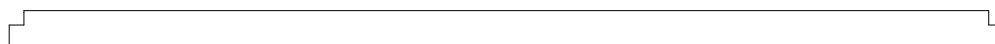

J1 | JOIST - W4L14556
(x1) | 1"x2 3/8"x64 3/4" (24x60x1644)

Owner's Manual - Parts Identification

Wood Components (Not to Scale)



K1 | GROUND BOARD - W4L14557
(x2) | 5/8"x5 1/4"x64 3/4" (16x134x1644)



K2 | GROUND BOARD - W4L14558
(x1) | 5/8"x5 1/4"x40 3/8" (16x134x1024)



K3 | FLOOR SUPPORT - W4L14559
(x1) | 5/8"x5 1/4"x40 3/8" (16x134x1024)



K4 | GROUND BOARD - W4L14560
(x1) | 5/8"x5 1/4"x78 1/4" (16x134x1986)

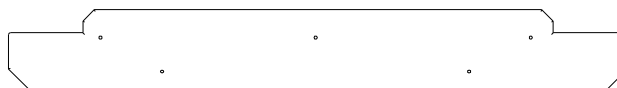

K5 | COUNTER TOP - W4L14561
(x1) | 5/8"x5 1/4"x40 3/8" (16x134x1024)



K6 | WALL BOARD - W4L14562
(x1) | 5/8"x5 1/4"x16 1/4" (16x134x412)



L1 | WALL RAIL - W4L14563
(x1) | 5/8"x4 3/8"x40 3/8" (16x112x1024)



L2 | WALL RAIL - W4L14564
(x1) | 5/8"x4 3/8"x64 3/4" (16x112x1644)



L3 | WALL RAIL - W4L14565
(x1) | 5/8"x4 3/8"x64 3/4" (16x112x1644)



L4 | WALL RAIL - W4L14566
(x1) | 5/8"x4 3/8"x40 3/8" (16x112x1024)



L5 | CLUB HOUSE WALL RAIL - W4L14567
(x1) | 5/8"x4 3/8"x40 3/8" (16x112x1024)



L6 | BAY WINDOW HEADER - W4L14568
(x2) | 5/8"x4 3/8"x30 1/2" (16x112x774)

Owner's Manual - Parts Identification

Wood Components (Not to Scale)



L7 | DOOR BOARD - W4L14569
(x1) | 5/8"x4 3/8"x35" (16x110x890)



L8 | DOOR BOARD - W4L14570
(x1) | 5/8"x4 3/8"x35" (16x110x890)



M1 | FLOOR SUPPORT - W4L14571
(x1) | 5/8"x3 3/8"x64 3/4" (16x86x1644)



M2 | FLOOR SUPPORT - W4L14572
(x2) | 5/8"x3 3/8"x40 3/8" (16x86x1024)

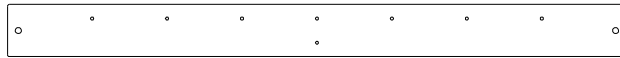

M3 | FLOOR SUPPORT - W4L14573
(x1) | 5/8"x3 3/8"x40 3/8" (16x86x1024)

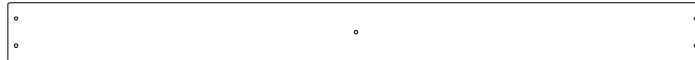

M4 | FLOOR BOARD - W4L14574
(x2) | 5/8"x3 3/8"x40 3/8" (16x86x1024)



M5 | FLOOR BOARD - W4L14575
(x1) | 5/8"x3 3/8"x40 3/8" (16x86x1024)



M6 | FLOOR BOARD - W4L14576
(x1) | 5/8"x3 3/8"x37 1/2" (16x86x952)



M7 | FLOOR SUPPORT - W4L14577
(x1) | 5/8"x3 3/8"x40 3/8" (16x86x1024)

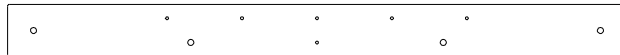

M8 | FLOOR SUPPORT - W4L14578
(x1) | 5/8"x3 3/8"x40 3/8" (16x86x1024)

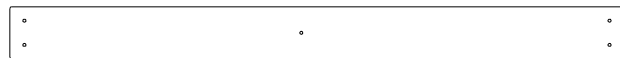

M9 | WALL BOARD - W4L14579
(x2) | 5/8"x3 3/8"x40" (16x86x1016)

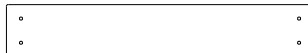

M10 | WALL BOARD - W4L14580
(x9) | 5/8"x3 3/8"x20" (16x86x508)



M11 | FLOOR SUPPORT - W4L14581
(x1) | 5/8"x3 3/8"x37 1/2" (16x86x951)



M12 | WALL BOARD - W4L14582
(x9) | 5/8"x3 3/8"x38 7/8" (16x86x986)

Owner's Manual - Parts Identification

Wood Components (Not to Scale)



M13 | WALL BOARD - W4L14583
(x9) | 5/8"x3 3/8"x22" (16x86x558)



M14 | WALL BOARD - W4L14584
(x1) | 5/8"x3"x36 1/2" (16x76x926)



M15 | WALL RAIL - W4L14585
(x2) | 5/8"x3 3/8"x8 1/2" (16x86x216)



M16 | WALL RAIL - W4L14586
(x2) | 5/8"x3 3/8"x40 3/8" (16x86x1024)

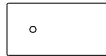

M17 | WALL RAIL - W4L14587
(x1) | 5/8"x3 3/8"x6 3/4" (16x86x173)



M18 | WALL RAIL - W4L14588
(x1) | 5/8"x3 3/8"x4 3/4" (16x86x122)

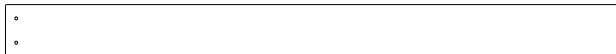

M19 | WALL BOARD - W4L14589
(x2) | 5/8"x3 3/8"x40 5/8" (16x86x1032)



M20 | WALL BOARD - W4L14590
(x2) | 5/8"x3 3/8"x16 1/4" (16x86x412)

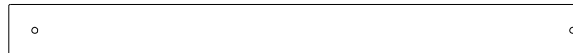

M21 | WALL RAIL - W4L14591
(x2) | 5/8"x3 3/8"x37 1/2" (16x86x951)



M22 | WALL BOARD - W4L14592
(x1) | 5/8"x2 7/8"x38 7/8" (16x73x986)



M23 | DOOR BOARD - W4L14593
(x2) | 5/8"x3 3/8"x35 3/4" (16x86x908)



M24 | DOOR BOARD - W4L14594
(x2) | 5/8"x3 3/8"x21 1/4" (16x86x540)



M25 | DOOR BOARD - W4L14595
(x2) | 5/8"x3 3/8"x6 1/4" (16x86x160)



M26 | WALL BOARD - W4L14596
(x8) | 5/8"x3 3/8"x3 1/2" (16x86x88)

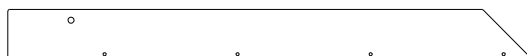

M27 | ROOF RAFTER - W4L14597
(x4) | 5/8"x3 3/8"x34 1/4" (16x86x871)

Owner's Manual - Parts Identification

Wood Components (Not to Scale)



M30 | FLOOR SUPPORT - W4L14598
(x1) | 5/8"x3 3/8"x64 3/4" (16x86x1644)



M31 | GABLE BOARD - W4L14599
(x2) | 5/8"x3 3/8"x31 1/2" (16x86x800)



M33 | WALL BOARD - W4L14600
(x1) | 5/8"x3"x36 1/2" (16x76x926)



M34 | FILLER BOARD - W4L14617
(x1) | 5/8"x1 3/4"x33 1/2" (16x45x851)



M77 | SLIDE BRACE - W4L08748
(x1) | 5/8"x3 3/8"x17 1/4" (16x86x438)



M78 | CENTER SLIDE BRACE - W4L08749
(x2) | 5/8"x3 3/8"x17 1/4" (16x86x438)



M102 | REAR SUPPORT - W4L17614
(x1) | 5/8"x3 3/8"x19 1/8" (16x86x486)

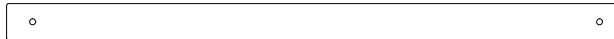

N1 | SAFETY BOARD - W4L14602
(x1) | 5/8"x2 3/8"x40 3/8" (16x60x1024)



N2 | PICKET - W4L14603
(x6) | 5/8"x2 3/8"x22" (16x60x558)

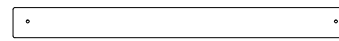

N3 | WALL BOARD - W4L14604
(x1) | 5/8"x2"x22" (16x50x558)



N4 | BAY WINDOW BOARD - W4L14605
(x6) | 5/8"x2 3/8"x13 1/8" (16x60x332)

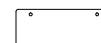

N5 | BAY WINDOW BOARD - W4L14606
(x6) | 5/8"x2 3/8"x6 1/4" (16x60x158)



N7 | BENCH CLEAT - W4L14607
(x1) | 5/8"x2 3/8"x5 1/8" (16x60x130)

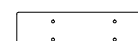

N9 | DOOR STOP - W4L14608
(x1) | 5/8"x2 3/8"x8 3/4" (16x60x222)

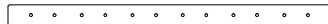

O1 | DOOR CLEAT - W4L14609
(x3) | 5/8"x1 3/8"x21" (16x34x534)



O2 | WALL BOARD - W4L14610
(x2) | 5/8"x1 3/8"x15 1/2" (16x34x395)



S1 | FLOOR SUPPORT - W4L14612
(x2) | 1"x1"x59 7/8" (24x24x1522)

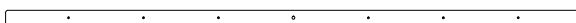

S2 | FLOOR SUPPORT - W4L14613
(x1) | 1"x1"x37 1/2" (24x24x952)

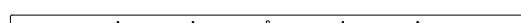

S3 | FLOOR SUPPORT - W4L14614
(x1) | 1"x1"x33 1/2" (24x24x852)

Owner's Manual - Parts Identification

Wood Components (Not to Scale)



SB74 | SWING BEAM EXTENDED - W4L06925
(x1) | 2"x5 1/4"x89 1/2" (50x134x2274)



W71 | SWING BEAM SUPPORT - W4L14615
(x1) | 2"x3 3/8"x50 3/8" (50x86x1280)



Y1 | WALL BOARD - W4L14616
(x2) | 5/8"x4"x34 5/8" (16x102x880)

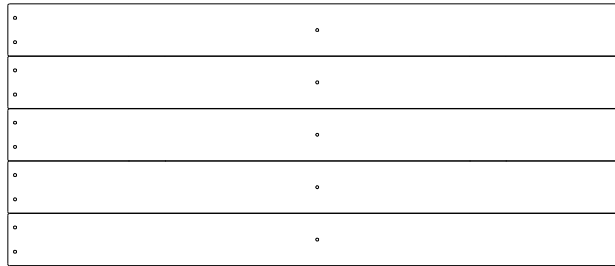

FP1 | FLOOR PANEL - W2A03131
(x3) | 1 1/4"x17"x40 5/16" (32x432x1024)

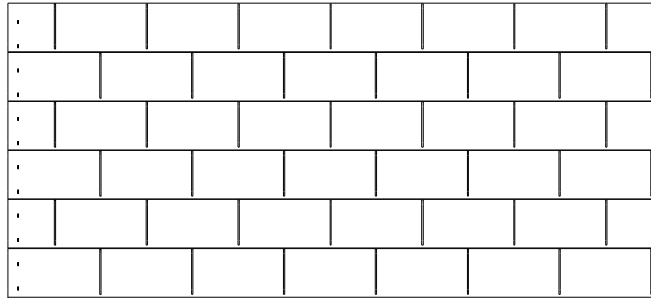

RP1 | ROOF PANEL - W2A03133
(x2) | 1 1/16"x19 5/16"x42 5/8" (35x491x1083)

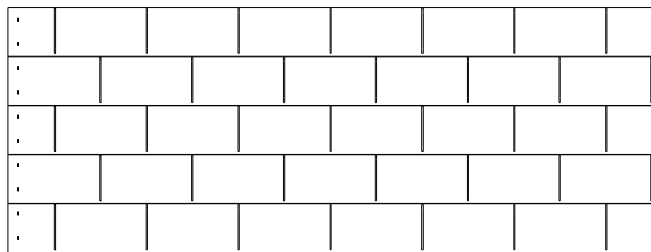

RP2 | ROOF PANEL - W2A03134
(x2) | 1 1/16"x16 1/8"x42 5/8" (35x410x1083)

Owner's Manual - Parts Identification

Hardware Components

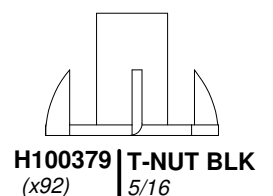
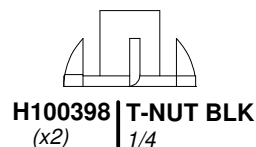
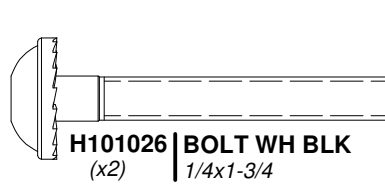
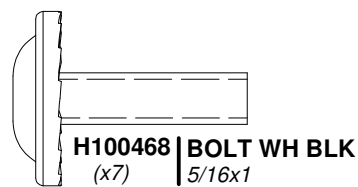
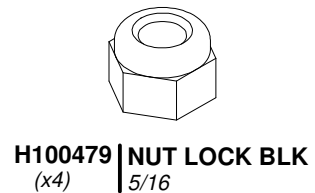
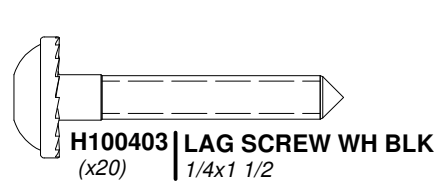
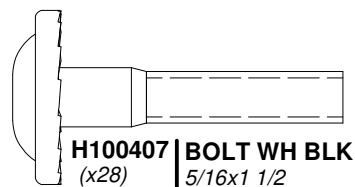
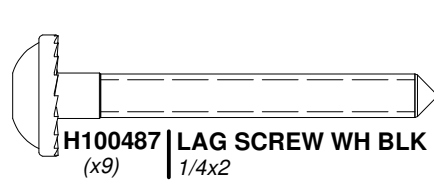
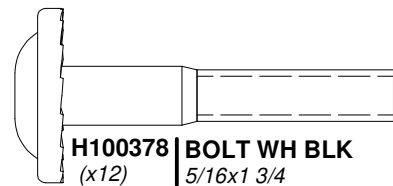
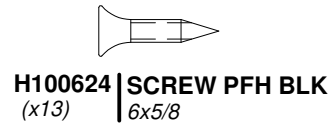
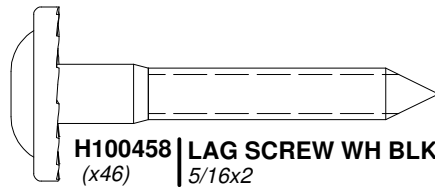
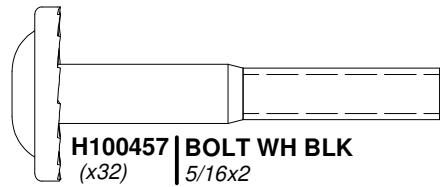
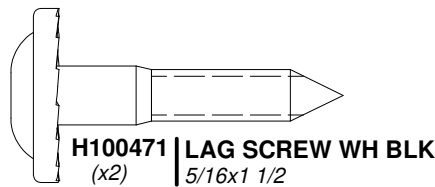
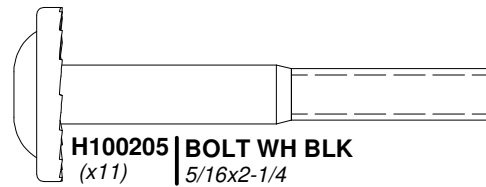
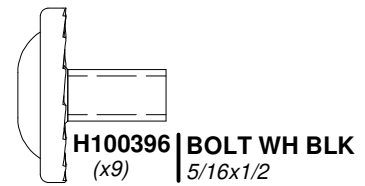
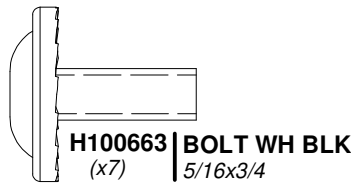
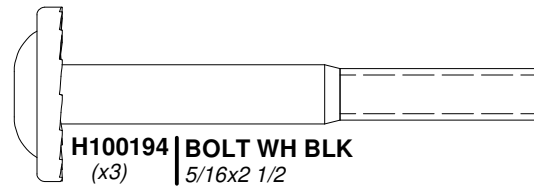
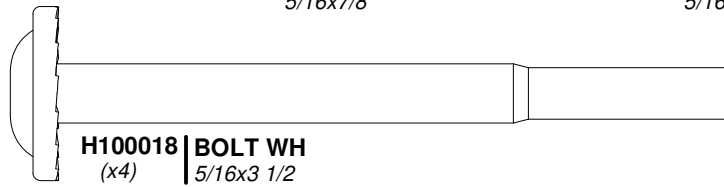
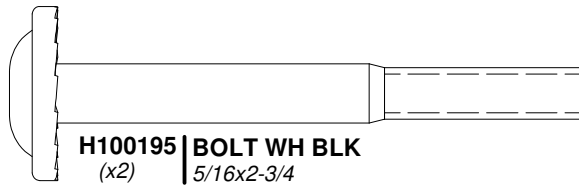
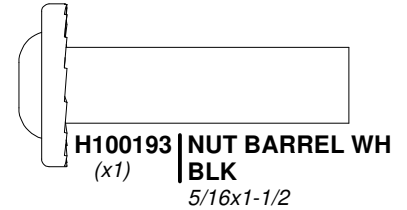
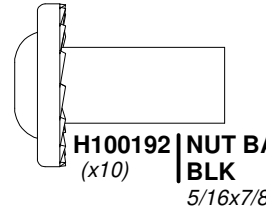
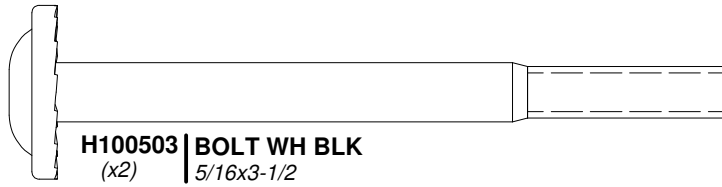
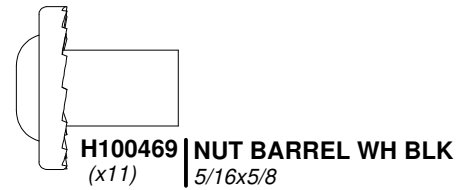

Owner's Manual - Parts Identification

Hardware Components

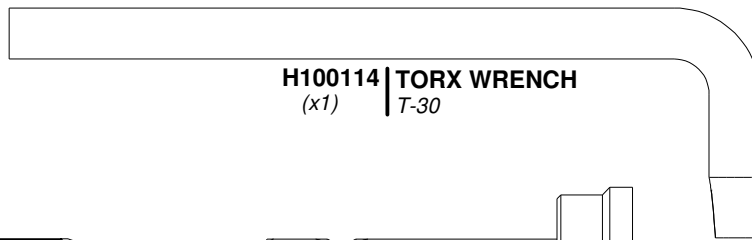

H100114 | TORX WRENCH
(x1) | T-30



H100147 | TORX BIT
(x1) | T-30

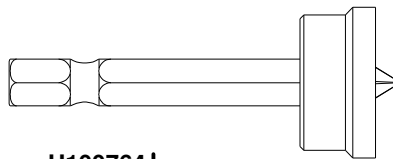

H100764 | SCREW SETTER
(x1)

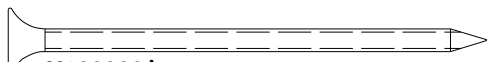

H100090 | SCREW PFH
(x48) | 8x2 1/2"

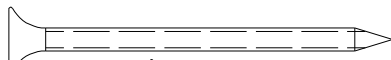

H100111 | SCREW PFH
(x7) | 8x2

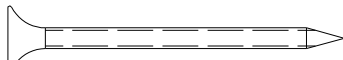

H100089 | SCREW PFH
(x33) | 8x1 3/4

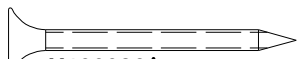

H100086 | SCREW PFH
(x144) | 8x1 1/2

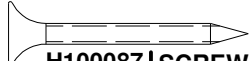

H100087 | SCREW PFH
(x8) | 8x1 1/4

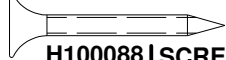

H100088 | SCREW PFH
(x283) | 8x1 1/8

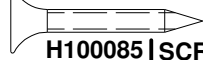

H100085 | SCREW PFH
(x4) | 8x1

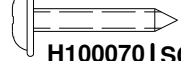

H100070 | SCREW PWH
(x35) | 8x3/4

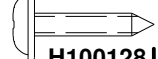

H100128 | SCREW PWH
(x4) | 8x5/8

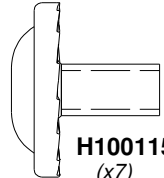

H100115 | BOLT WH
(x7) | 5/16x1/2

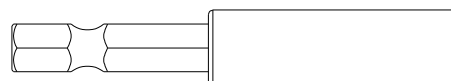

H101100 | MAGNETIC DRIVER
(x1)

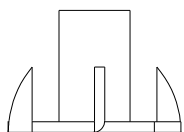

H100074 | T-NUT
(x11) | 5/16

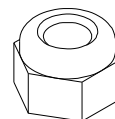

H100110 | NUT LOCK
(x7) | 5/16

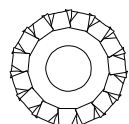

H100405 | WASHER LOCK EXT BLK
(x17) | 6x15

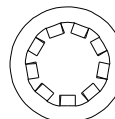

H100473 | WASHER LOCK INT BLK
(x2) | 8x15

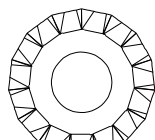

H100198 | WASHER LOCK EXT BLK
(x110) | 8x19

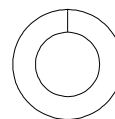

H100477 | WASHER SPLIT BLK
(x4) | 5/16

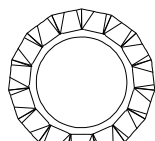

H100199 | WASHER LOCK EXT BLK
(x15) | 12x19

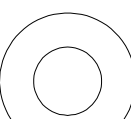

H100474 | WASHER FLAT BLK
(x2) | 9x18

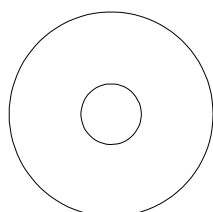

H100105 | WASHER FLAT
(x7) | 8x27

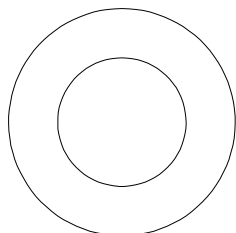

H100103 | WASHER SAFETY
(x7) | 17x30

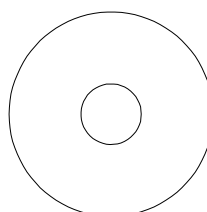

H100478 | WASHER FLAT BLK
(x11) | 8x27

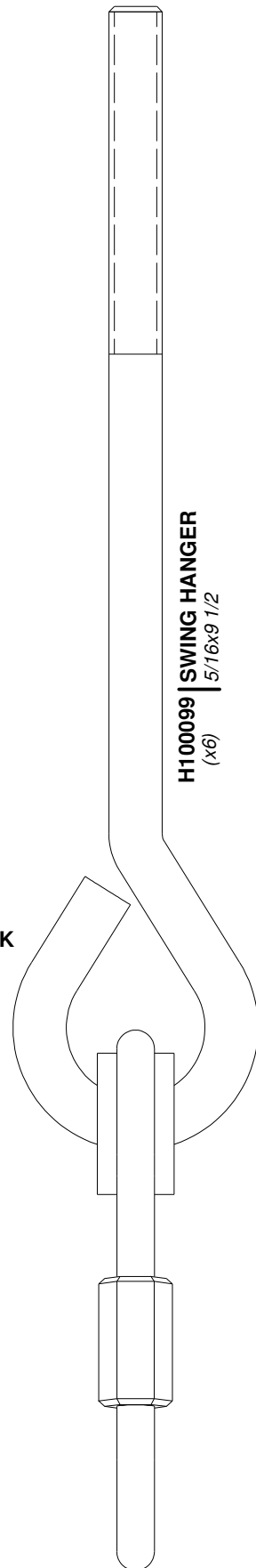

H100099 | SWING HANGER
(x6) | 5/16x9 1/2

Owner's Manual - Parts Identification

Accessory Components (Not to Scale)

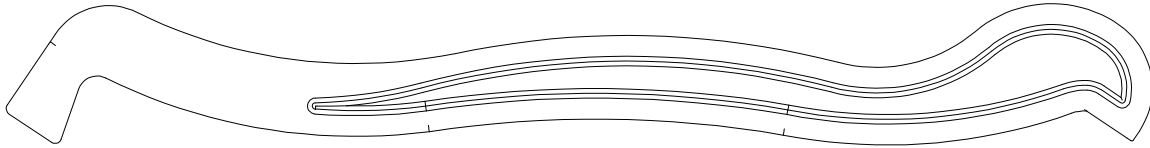

A100055 | SLIDE RAIL 8' GREEN LEFT
(x1)



A100054 | SLIDE RAIL 8' GREEN RIGHT
(x1)



A100356 | SLIDE BED 8' LIGHT GREEN
(x1)

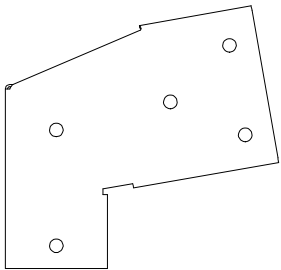

A100326 | SWING BEAM
EXTENSION
BRACKET-RIGHT
(x1)

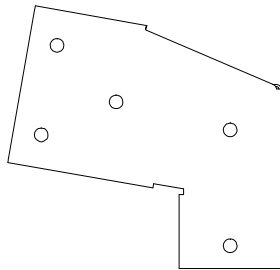

A100325 | SWING BEAM
EXTENSION
BRACKET-LEFT
(x1)

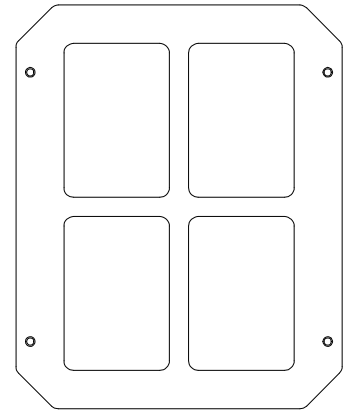

A100014 | PLASTIC WINDOW WHITE
(x6)

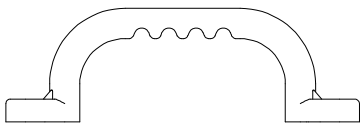

A100028 | HAND GRIP GREEN PLASTIC
(x4)

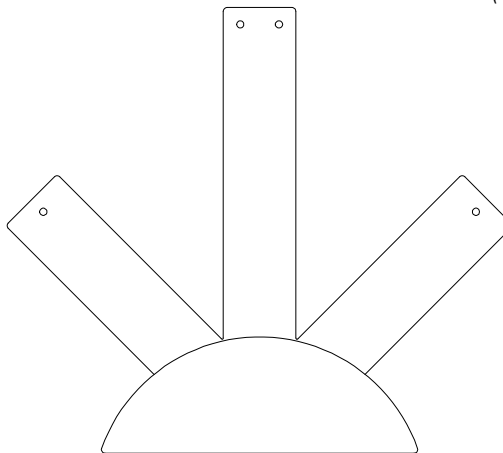

A100361 | PLASTIC SUNBURST
(x2)



A100164 | BYD ID TAG (LARGE) AGES 3-10
(x1)

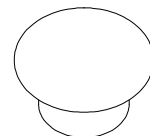

A6P00122 | KNOB - LT BROWN
(x1)

Owner's Manual - Parts Identification

Accessory Components (Not to Scale)

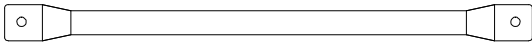

A100045 | METAL RUNG 559 GREEN
(x6)

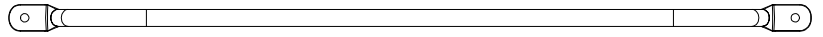

A100134 | HAND GRIP GREEN 816 C/C
(x2)

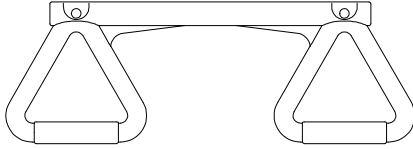

A6P00034 | TRAPEZE YELLOW
(x1)

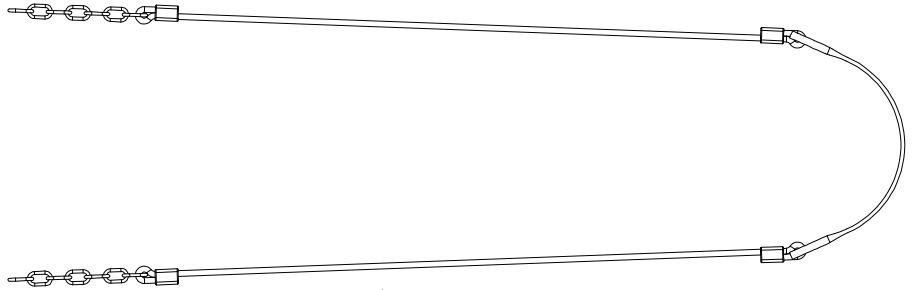

A6P00397 | ROPE-CHAIN GREEN / SEAT GREEN
(x2)

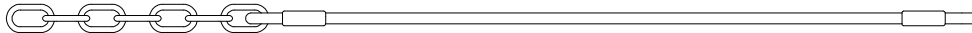

A100083 | ROPE-CHAIN GREEN 33"
(x2)

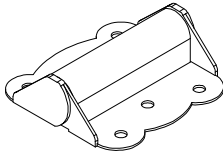

A4M00624 | HINGE (DOOR, SPRING LOADED)
(x2)

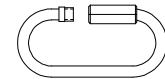

A100069 | QUICK LINK
(x2)

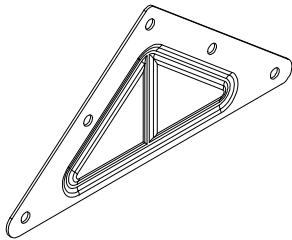

A100294 | TRIANGLE PLATE 100° 5 HOLE
(x2)

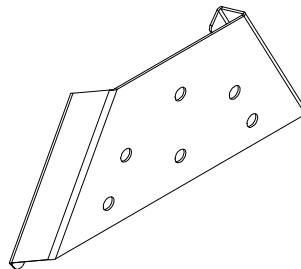

A4M01169 | A-FRAME BRACKET
(x1)

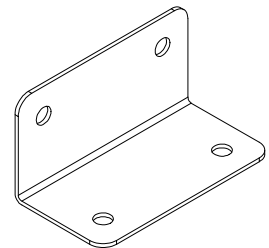

A100140 | L BRACKET 66x66x127
(x2)

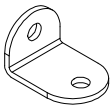

A100061 | L BRACKET GREEN 32x51
(x2)

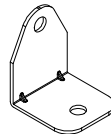

A100053 | L BRACKET 54x67 - GRN
(x2)

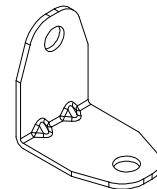

A4M01046 | L BRACKET 2.5x38x55x55
(x4)

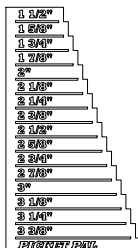

A6P00410 | PICKET PAL
(x1)



A100178 | AUGER GROUND STAKE
(x8)

PRE-ASSEMBLY STEP 1 - SORTING PARTS

It is critical for ease of assembly that you take the time to sort and organize the wood and hardware.

WOOD PARTS:

- Organize wood parts by the three-digit, alpha-numeric number stamped on each board (ex. P01).
- If there are multiple boards with the same stamped number, stack those pieces together.
- Stamps can be found on the flat surface of the boards or on the end of the boards.
- Allow yourself plenty of room - the wood pieces can take up a significant amount of space.

NOTE: CARTONS ARE NOT ORGANIZED BY BOARD NUMBER.

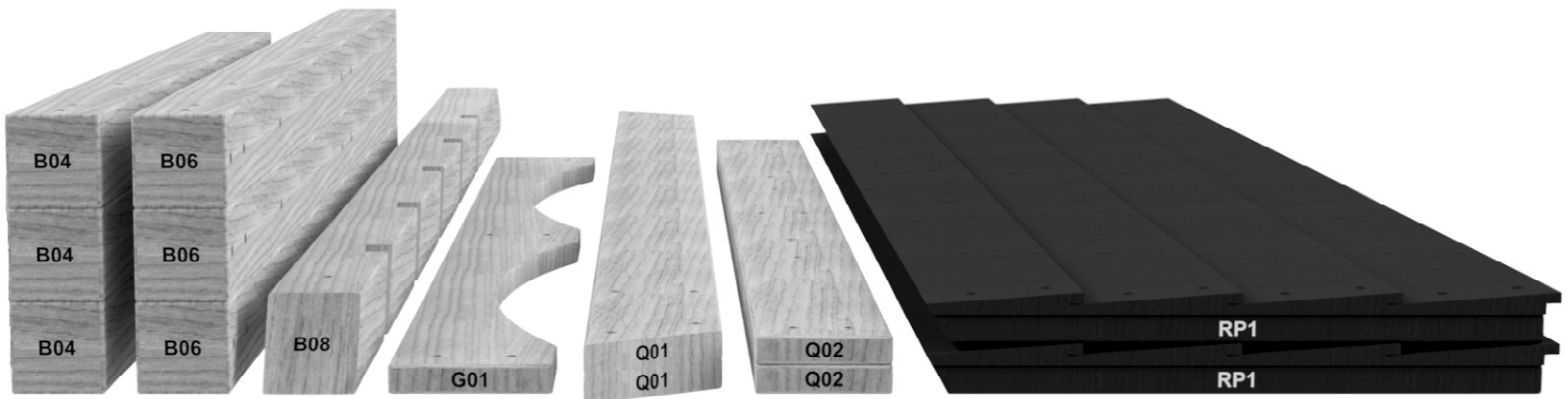

HARDWARE PARTS:

- We recommend that you have a separate table to organize the hardware.
- Hardware bags are printed with a seven-digit, alpha-numeric part number.
- You can organize your hardware by part number or group by hardware type (i.e. bolts, nuts, etc.).
- During assembly you only need to reference the last four digits of the number.

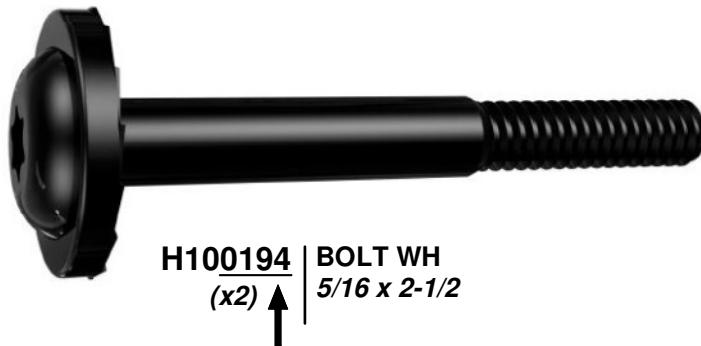

PRE-ASSEMBLY STEP 2 - TOOLS REQUIRED



**Cordless Drill or
Electric Drill**



**Drill Attachments:
Phillips Head**



**1/8", 3/16", 3/8" & 7/16"
Drill Bits**



Phillips Screw Driver



Open End Wrenches 1/2" & 9/16"



**3/8" Drive Ratchet, 1/2" &
9/16" STD Sockets 1/2" & 9/16" Deep
Sockets**



Claw Hammer



Rubber Mallet - Optional



Tape Measure

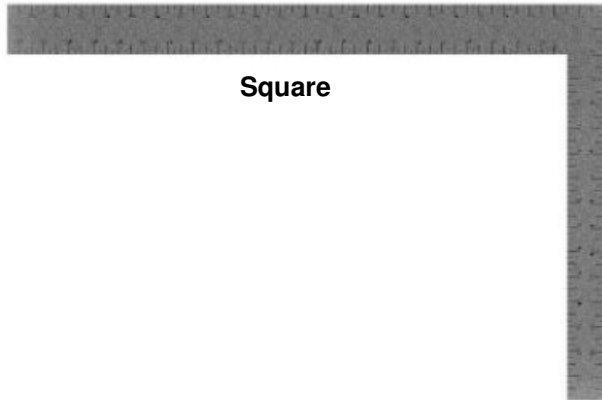

Square





Level 24"

PRE-ASSEMBLY STEP 3 - CHOOSE YOUR ASSEMBLY METHOD



There are several types of assembly instructions available to you.

1. Printed Assembly Manual included with your set
2. BILT APP - 3D interactive instructions
3. Combination of the Printed Manual and BILT APP (Note: Step numbers can differ between the two methods)

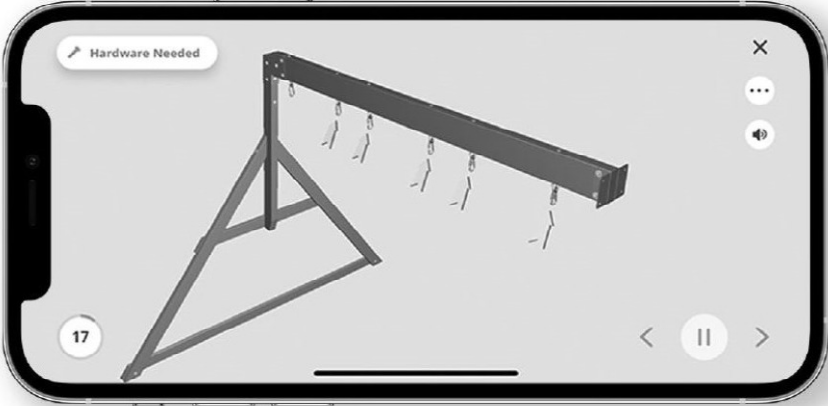

Scan for easy 3D instructions

Download the BILT app before you begin



The image shows a smartphone screen displaying the BILT app interface. The screen features a 3D assembly diagram of a metal frame with a horizontal beam and several hanging components. The interface includes a 'Hardware Needed' button at the top left, a close button (X) at the top right, a menu button (three dots) and a volume icon below it, and a page number '17' in a circle at the bottom left. At the bottom center, there are navigation buttons: a back arrow, a pause button, and a forward arrow.

STEP 1 - LADDER ASSEMBLY

QTY	PART NUMBER	DESCRIPTION
8	H100090	SCREW PFH 8x2 1/2



H74 | LEFT UPRIGHT - W4L17611
(x1) | 1 3/8"x3 3/8"x50 3/4" (36x86x1290)

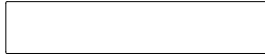

H81 | LADDER RUNG - W4L14554
(x4) | 1"x3 3/8"x17 1/8" (24x86x434)

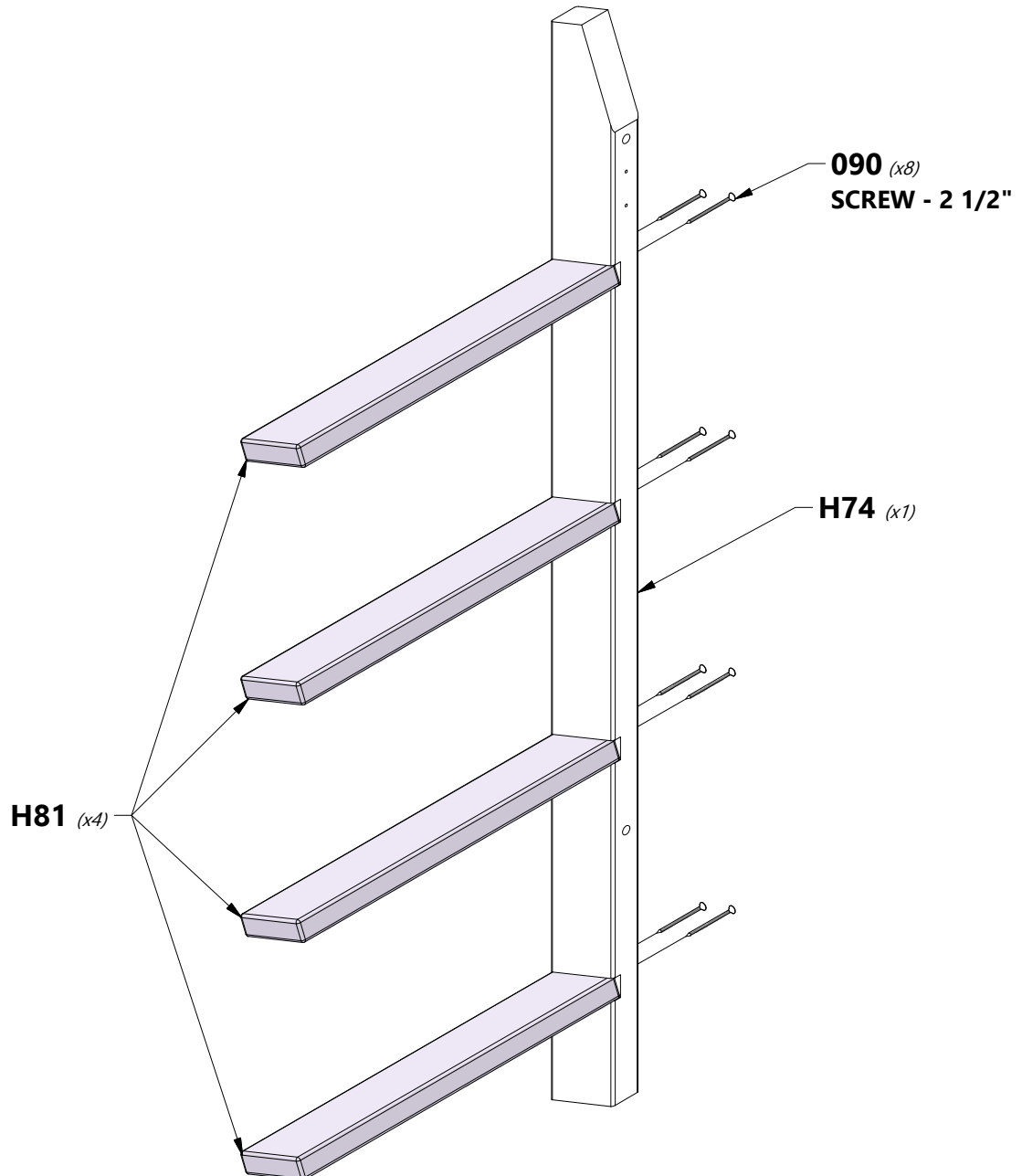

STEP 2 - LADDER ASSEMBLY

QTY	PART NUMBER	DESCRIPTION
8	H100090	SCREW PFH 8x2 1/2

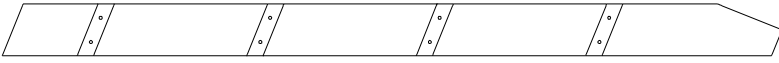

H75 | RIGHT UPRIGHT - W4L17612
(x1) | 1 3/8"x3 3/8"x50 3/4" (36x86x1290)

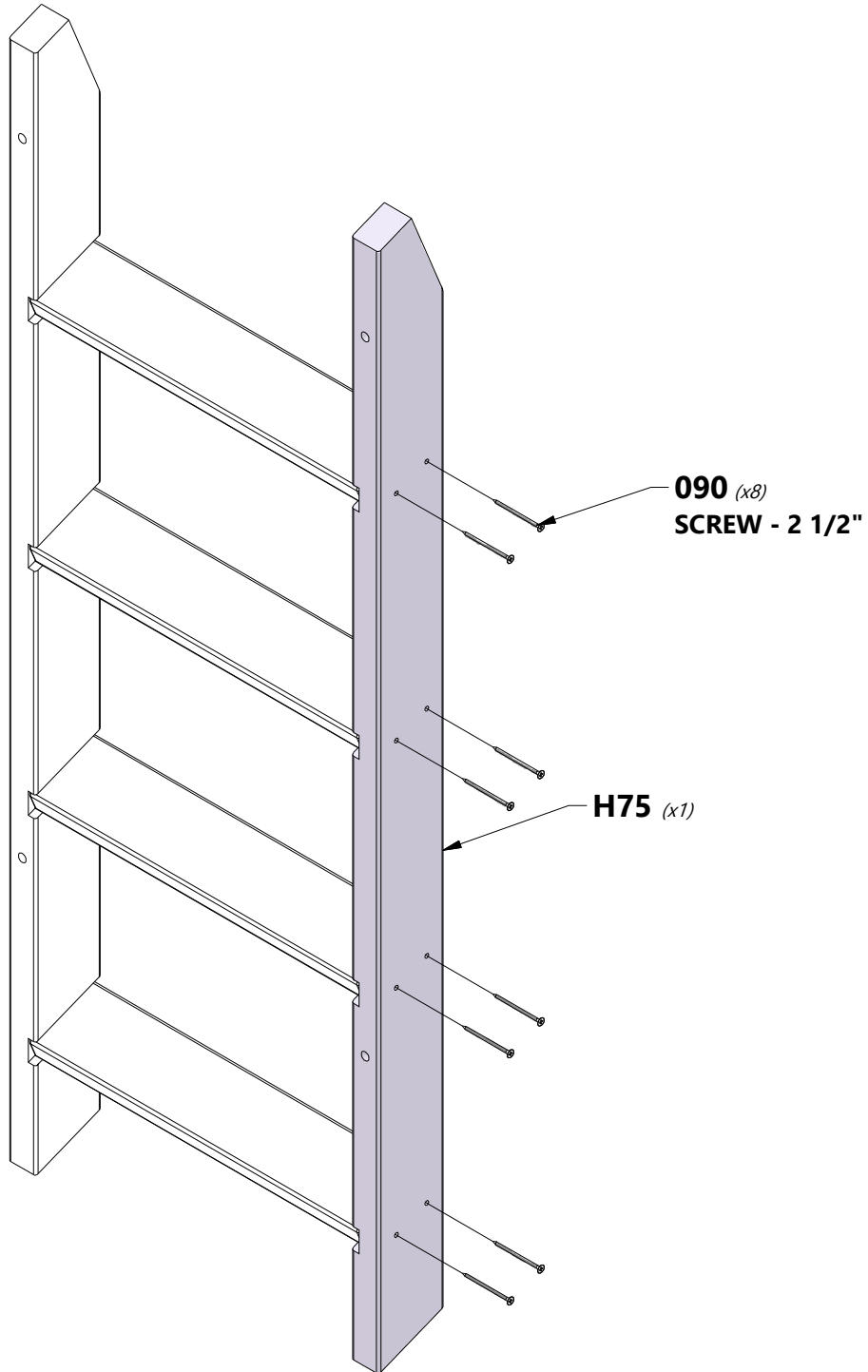

STEP 3 - LADDER ASSEMBLY

QTY	PART NUMBER	DESCRIPTION
4	H100086	SCREW PFH 8x1-1/2"
4	H100089	SCREW PFH 8x1-3/4"



M102 REAR SUPPORT - W4L17614
(x1) 5/8"x3 3/8"x19 1/8" (16x86x486)

H82 ATTACHMENT BOARD - W4L17613
(x1) 1"x3 3/8"x19 1/8" (24x86x486)

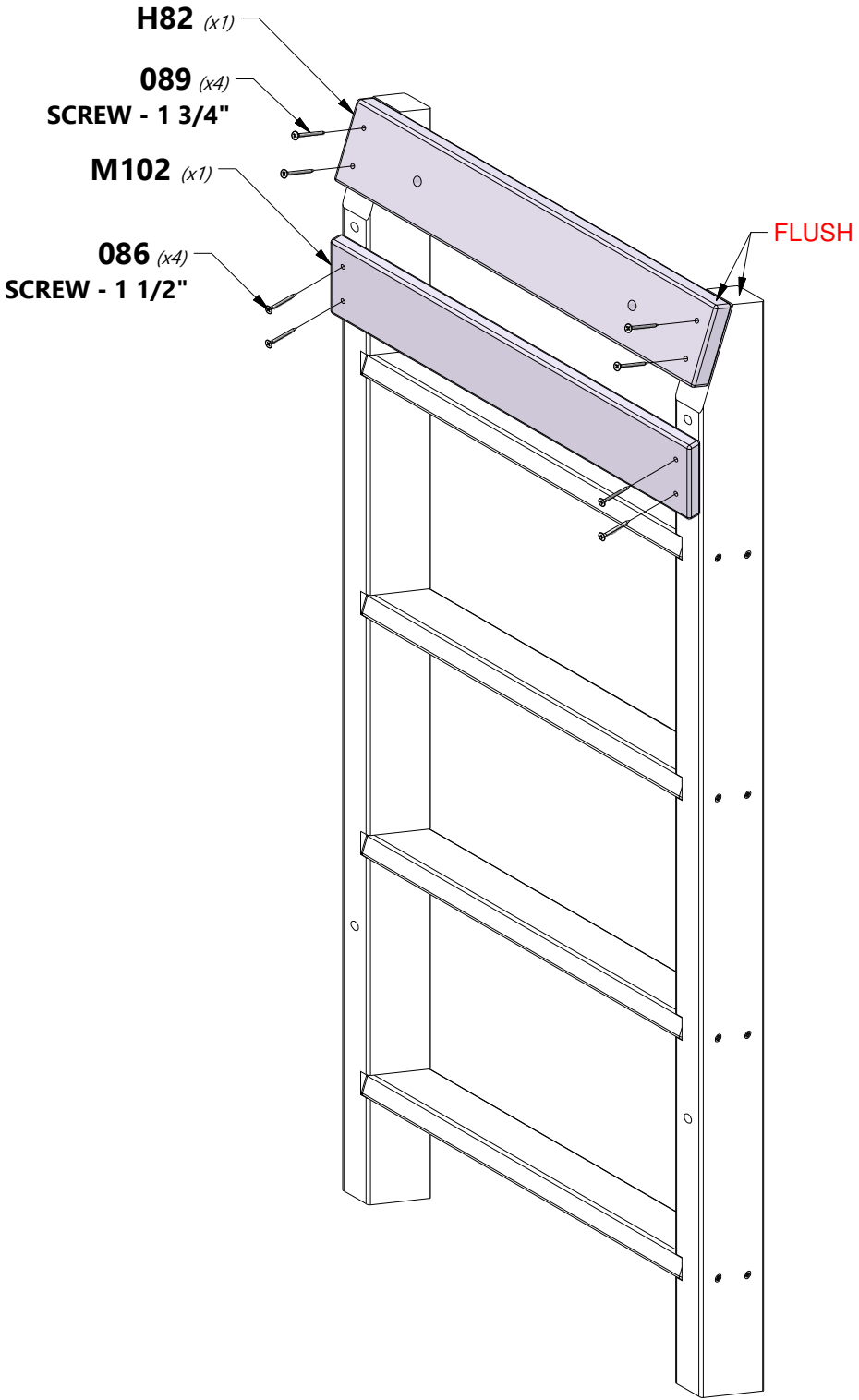

STEP 4 - LADDER ASSEMBLY

QTY	PART NUMBER	DESCRIPTION
4	H100018	BOLT WH 5/16x3 1/2
4	H100074	T-NUT 5/16

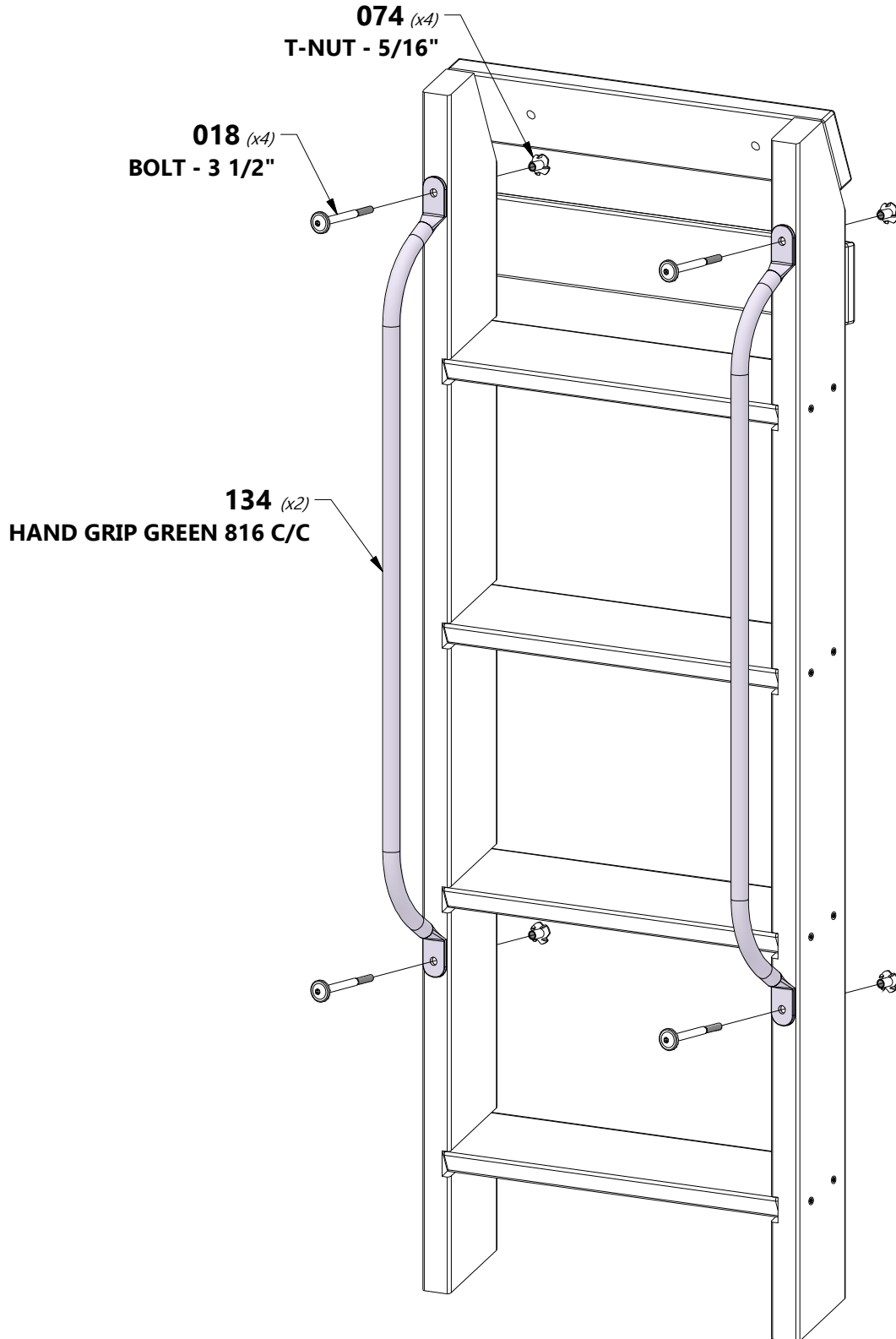

STEP 1 - BAY WINDOW ASSEMBLY

QTY	PART NUMBER	DESCRIPTION
8	H100088	SCREW PFH 8x1-1/8"



N5 | BAY WINDOW BOARD - W4L14606
(x2) | 5/8"x2 3/8"x6 1/4" (16x60x158)



N4 | BAY WINDOW BOARD - W4L14605
(x2) | 5/8"x2 3/8"x13 1/8" (16x60x332)

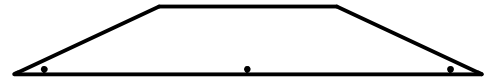

L6 | BAY WINDOW HEADER - W4L14568
(x2) | 5/8"x4 3/8"x30 1/2" (16x112x774)

TIP:
ASSEMBLE USING PILOT HOLES

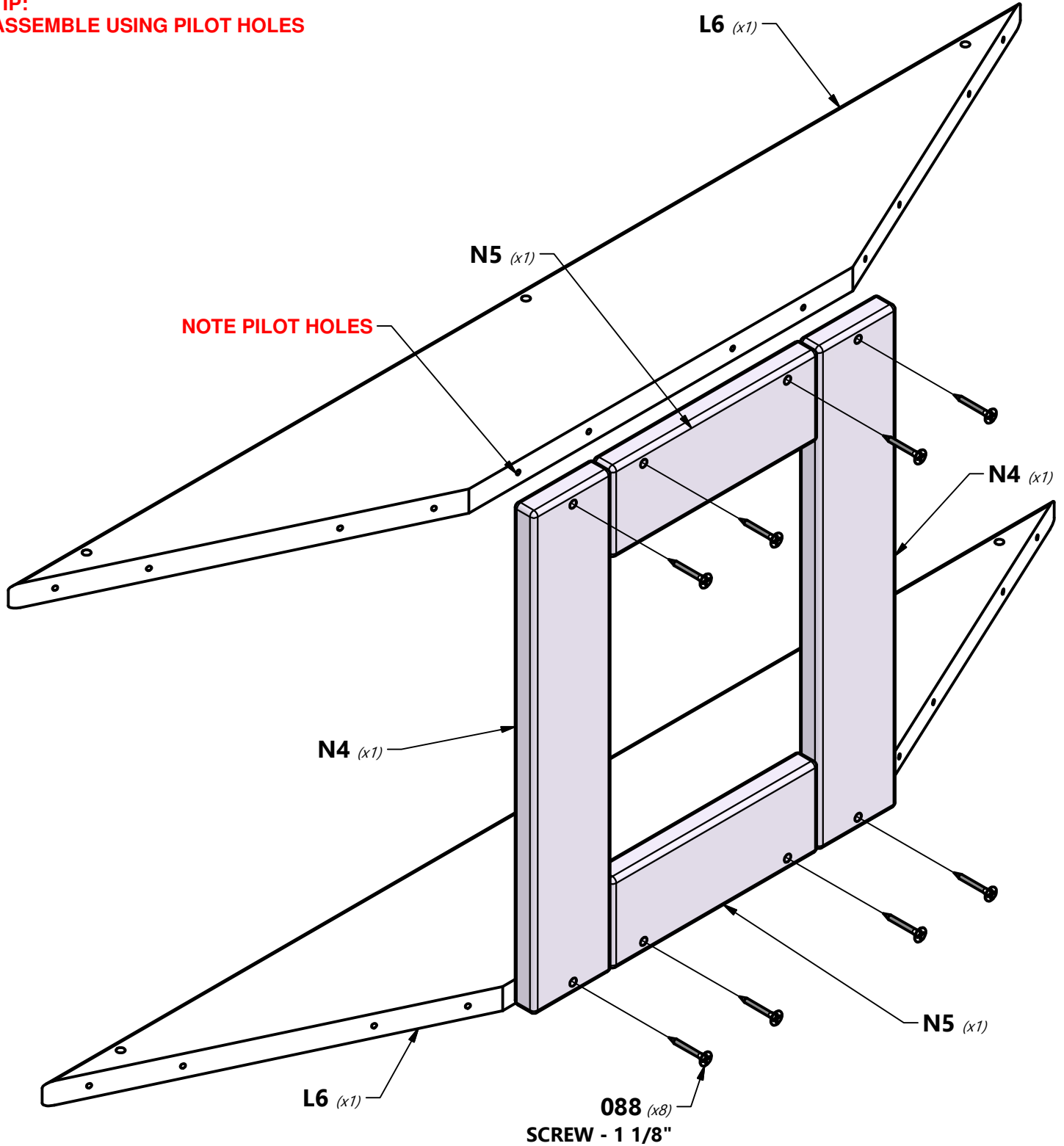

STEP 2 - BAY WINDOW ASSEMBLY

QTY	PART NUMBER	DESCRIPTION
2	H100085	SCREW PFH 8x1"
6	H100088	SCREW PFH 8x1-1/8"



N5 | BAY WINDOW BOARD - W4L14606
 (x2) | 5/8"x2 3/8"x6 1/4" (16x60x158)



N4 | BAY WINDOW BOARD - W4L14605
 (x2) | 5/8"x2 3/8"x13 1/8" (16x60x332)

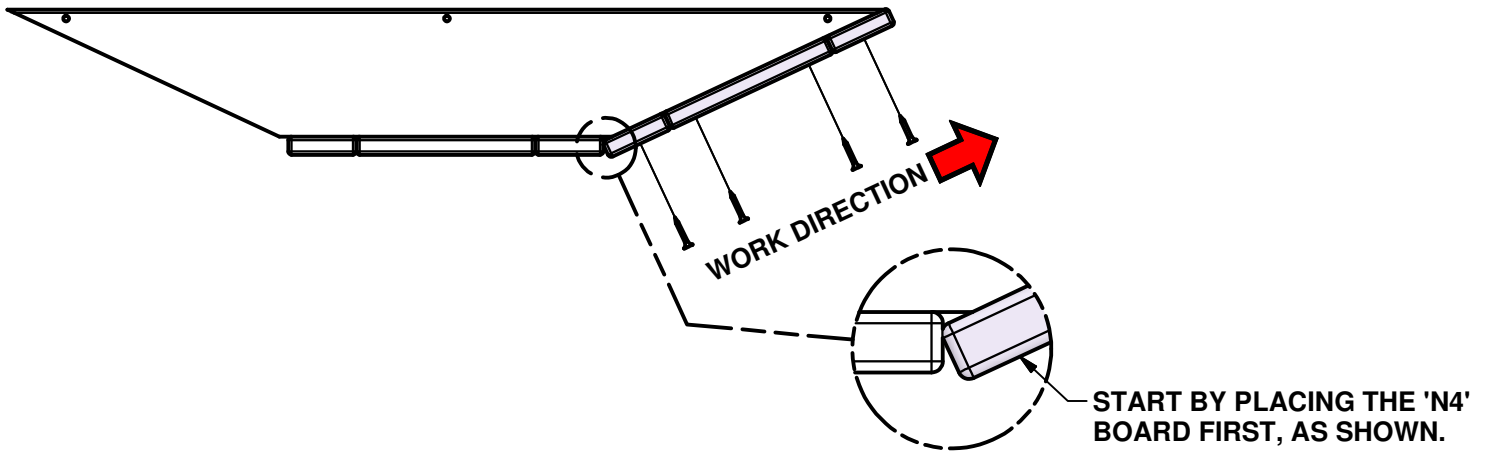
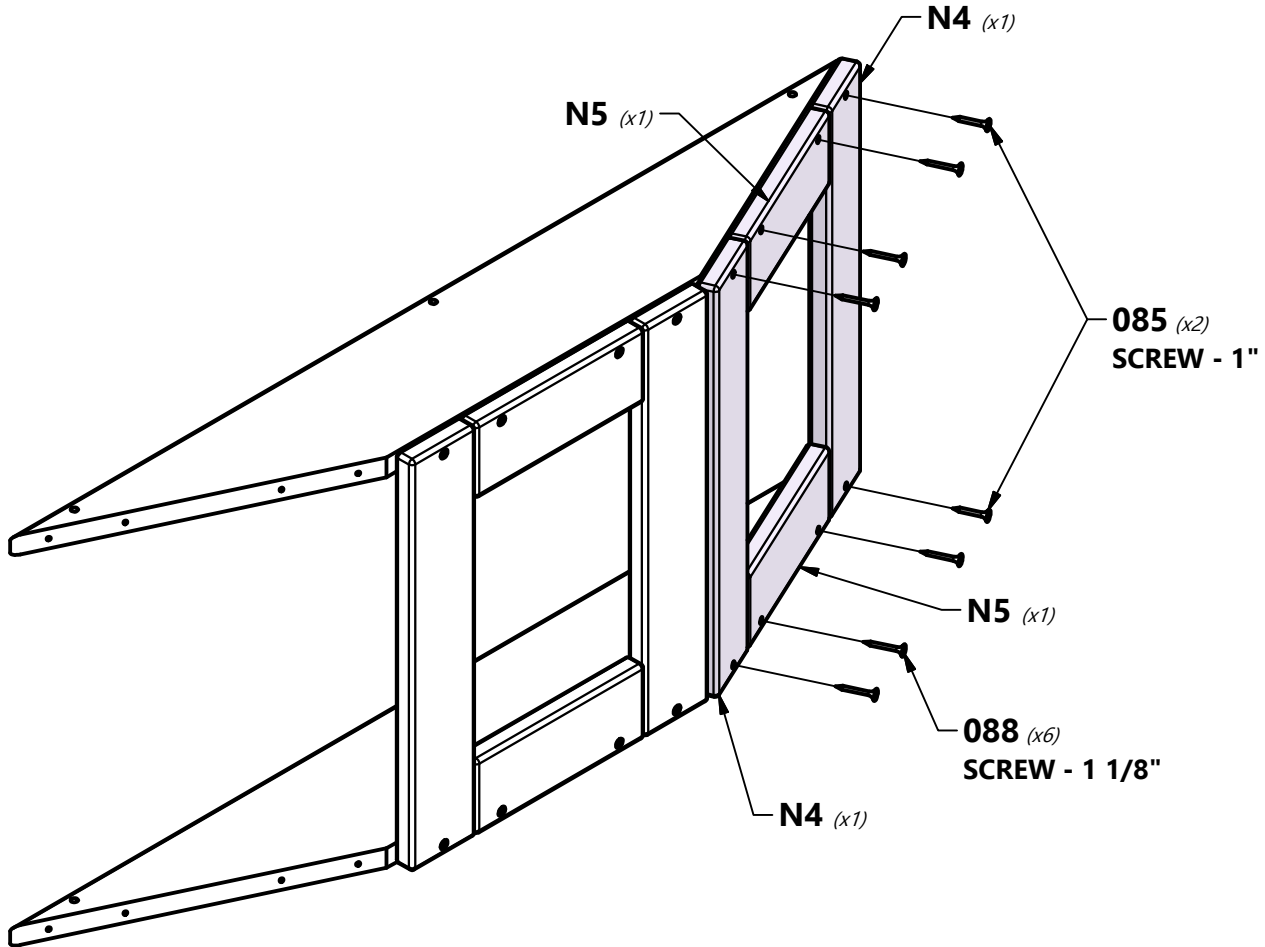

STEP 3 - BAY WINDOW ASSEMBLY

QTY	PART NUMBER	DESCRIPTION
2	H100085	SCREW PFH 8x1"
6	H100088	SCREW PFH 8x1-1/8"

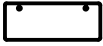

N5 | BAY WINDOW BOARD - W4L14606
 (x2) | 5/8"x2 3/8"x6 1/4" (16x60x158)



N4 | BAY WINDOW BOARD - W4L14605
 (x2) | 5/8"x2 3/8"x13 1/8" (16x60x332)

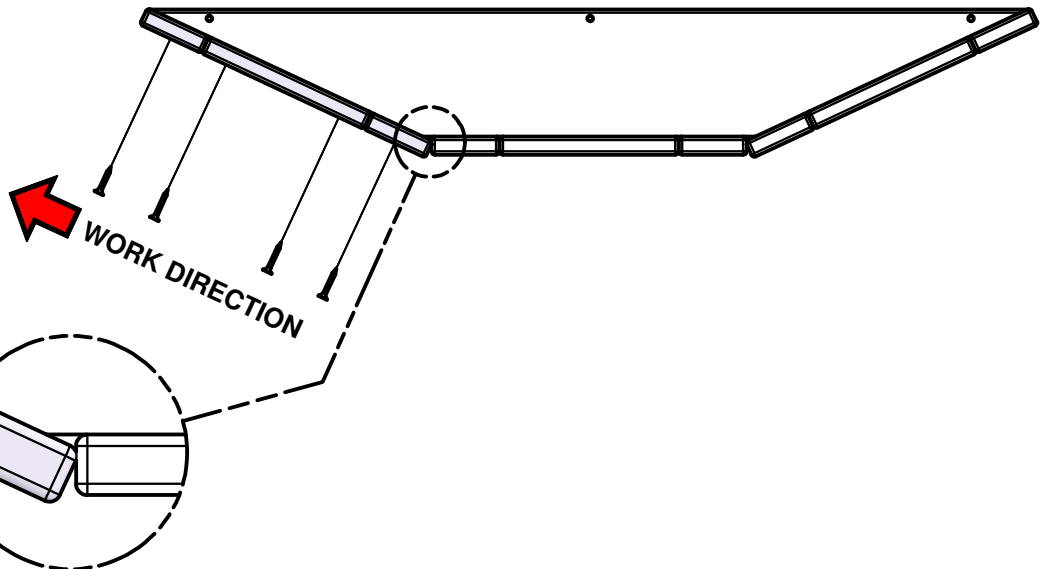
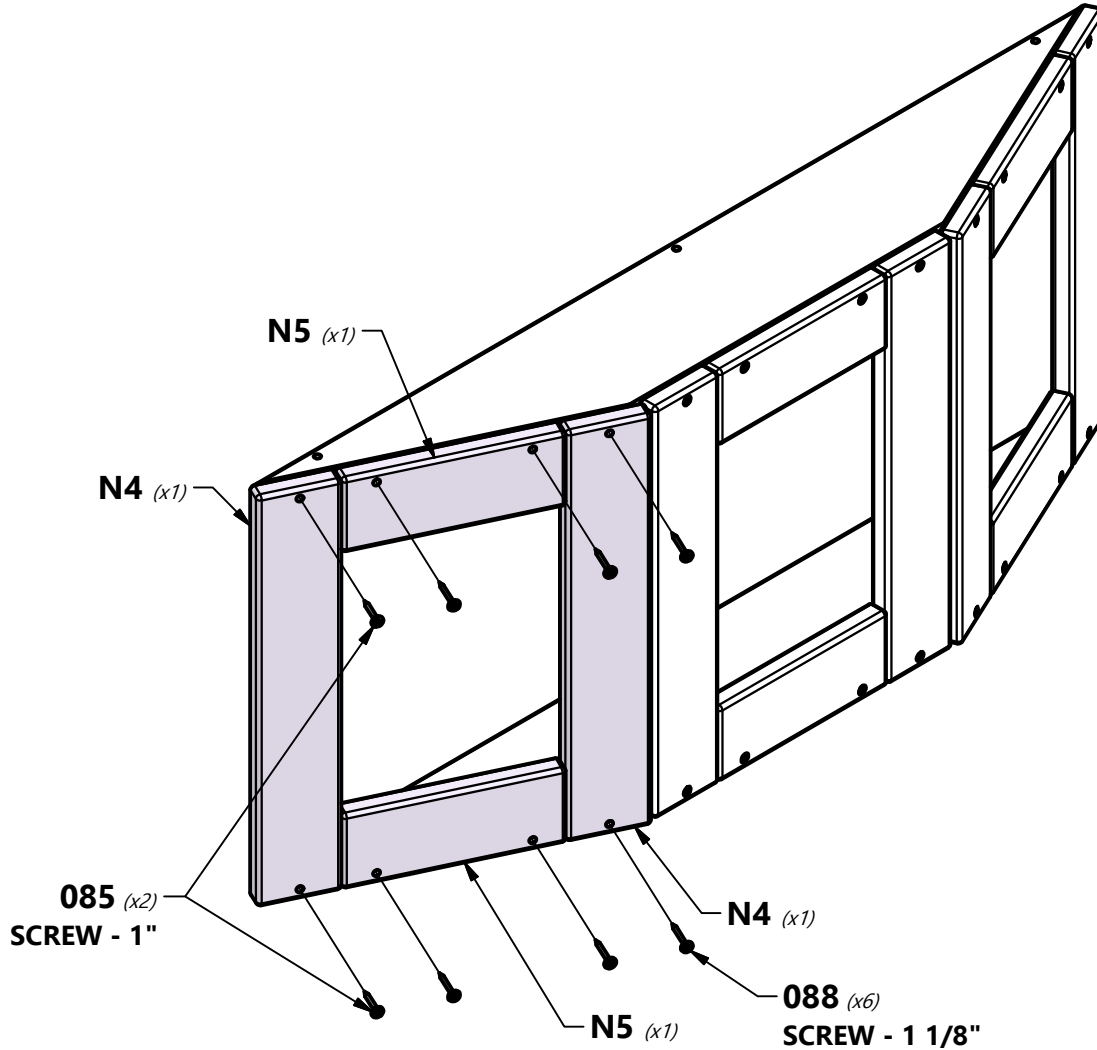

STEP 4 - BAY WINDOW ASSEMBLY

QTY	PART NUMBER	DESCRIPTION
12	H100070	SCREW PWH 8x3/4

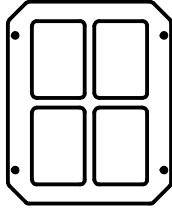

A100014
(x3) | PLASTIC WINDOW WHITE

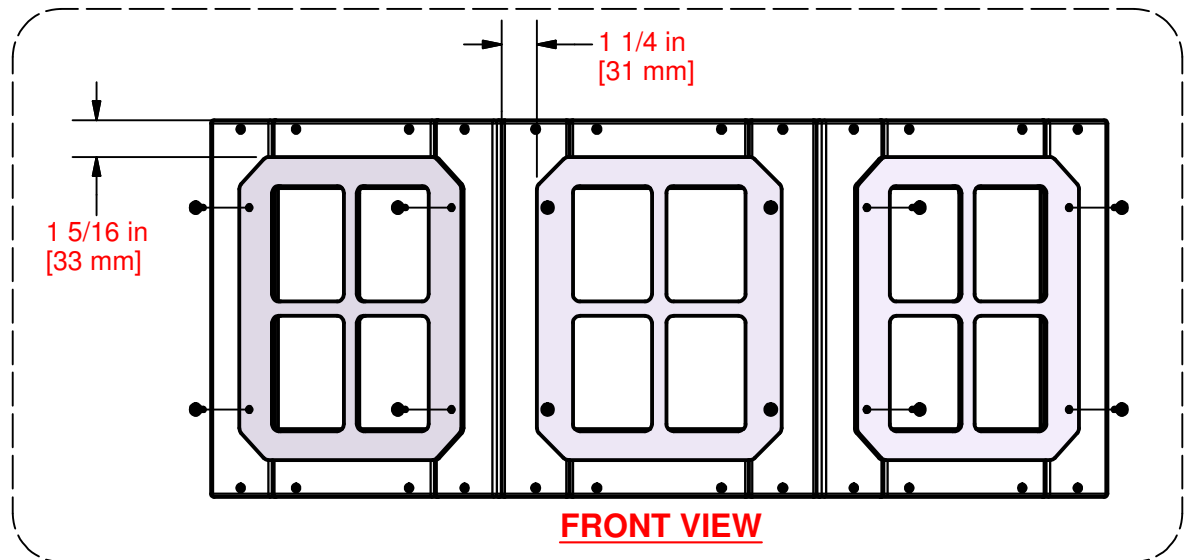
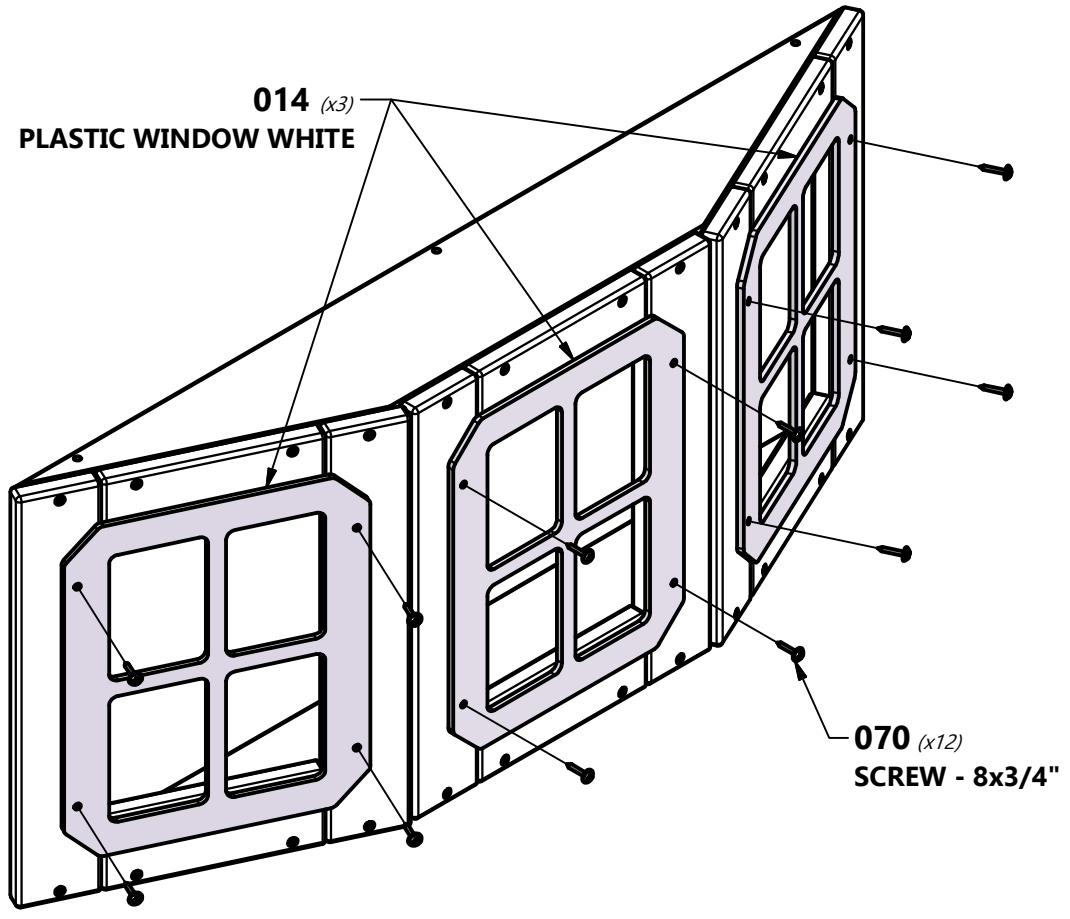

STEP 1 - BENCH ASSEMBLY

QTY	PART NUMBER	DESCRIPTION
2	H100199	WASHER LOCK EXT 12x19 BLK
2	H100469	NUT BARREL WH 5/16x5/8 BLK
2	H100663	BOLT WH 5/16x3/4 BLK



H7 | BENCH GROUND BOARD - W4L14546
 (x2) | 1"x3 3/8"x18 1/8" (24x86x460)



A100061 | L BRACKET GREEN 32x51
 (x2)

NOTE:
 ASSEMBLE A LEFT AND A RIGHT BENCH GROUND BOARD SUBASSEMBLY, SHOWN BELOW.

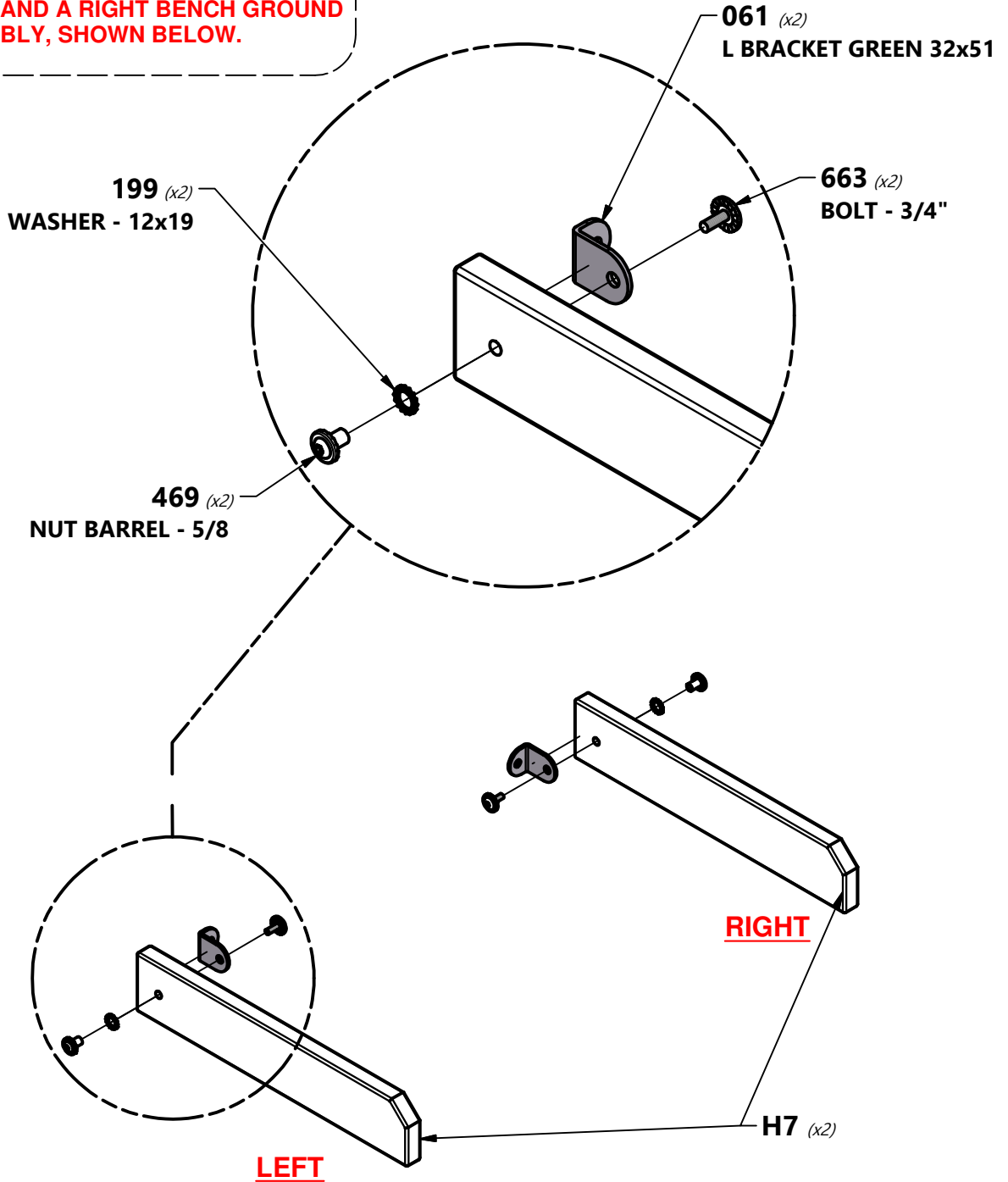

STEP 2 - BENCH ASSEMBLY

QTY	PART NUMBER	DESCRIPTION
8	H100089	SCREW PFH 8x1-3/4"



H8 | BENCH UPRIGHT - W4L14547
(x2) | 1"x3 3/8"x11 3/4" (24x86x300)

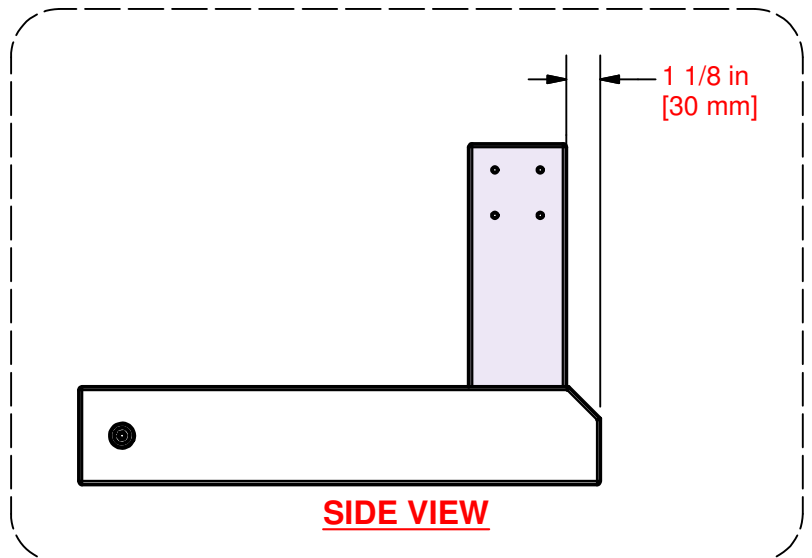
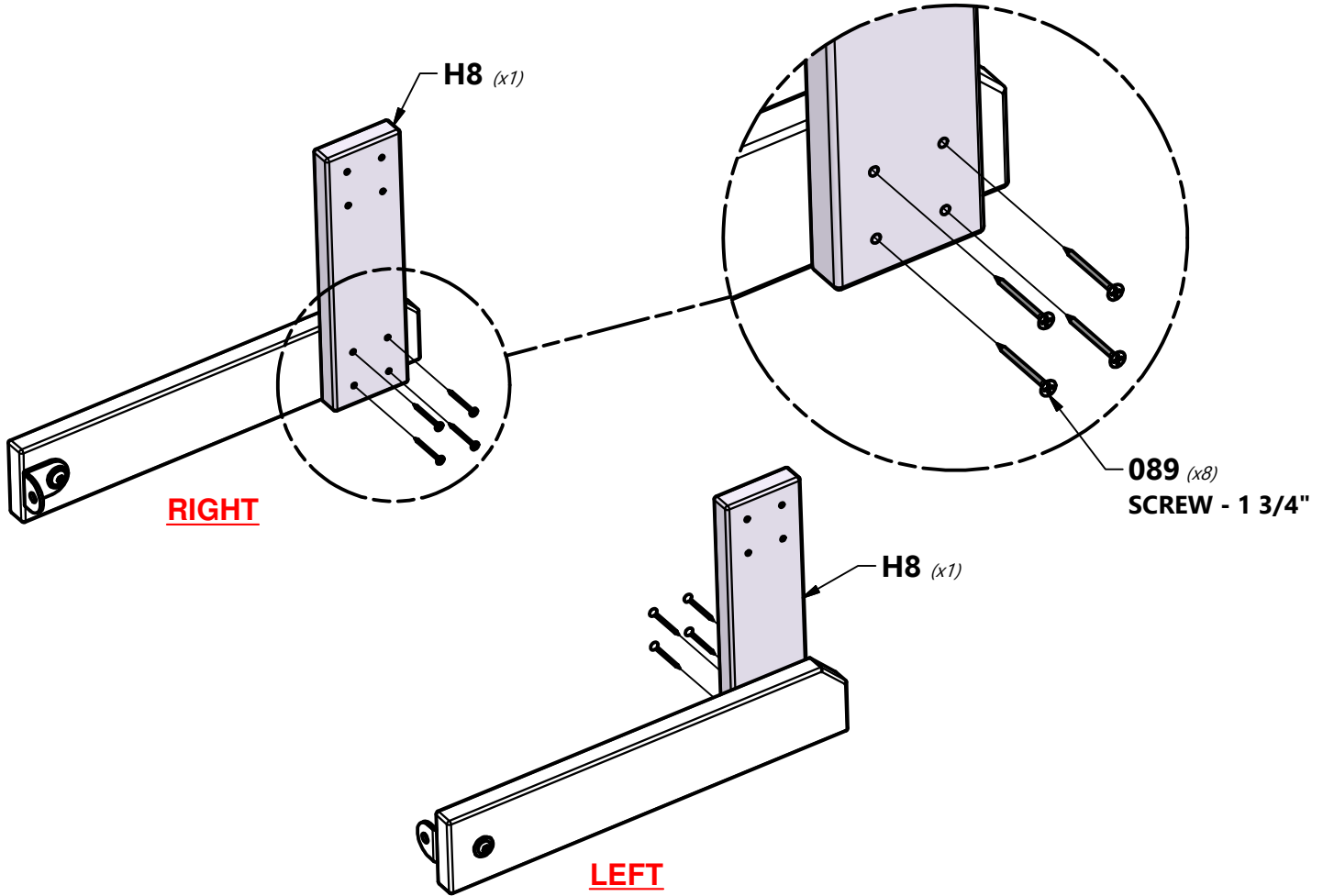

STEP 3 - BENCH ASSEMBLY

QTY	PART NUMBER	DESCRIPTION
8	H100089	SCREW PFH 8x1-3/4"



H9 | BENCH SEAT SUPPORT - W4L14548
(x2) | 1"x3 3/8"x6 1/2" (24x86x166)

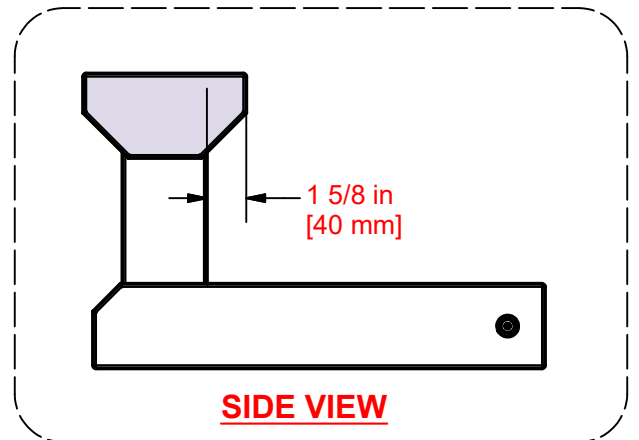
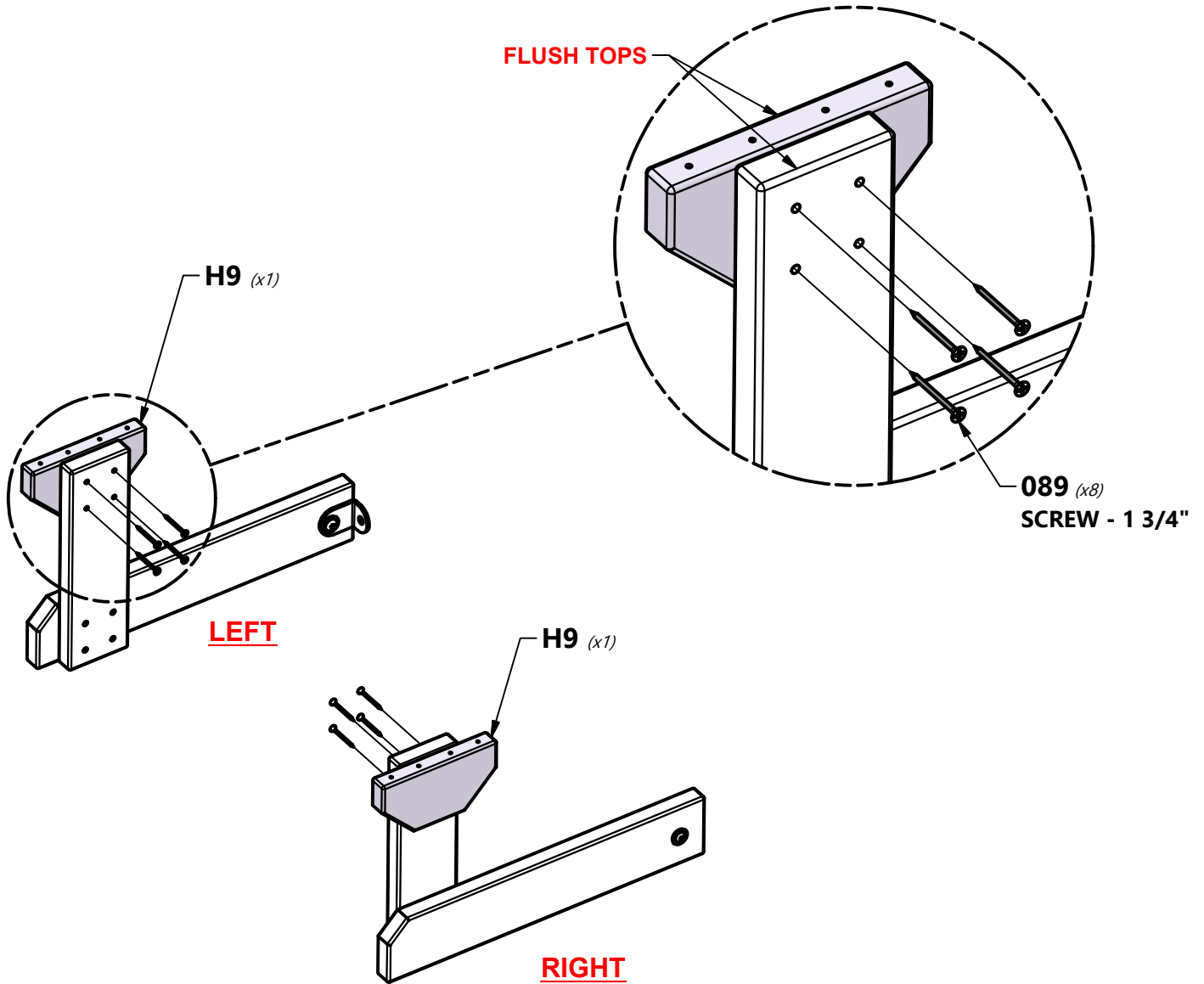

STEP 4 - BENCH ASSEMBLY

QTY	PART NUMBER	DESCRIPTION
4	H100088	SCREW PFH 8x1-1/8"
8	H100089	SCREW PFH 8x1-3/4"



H11 | BENCH SEAT - W4L14555
(x2) | 1"x3 3/8"x35 3/8" (24x86x900)



N7 | BENCH CLEAT - W4L14607
(x1) | 5/8"x2 3/8"x5 1/8" (16x60x130)

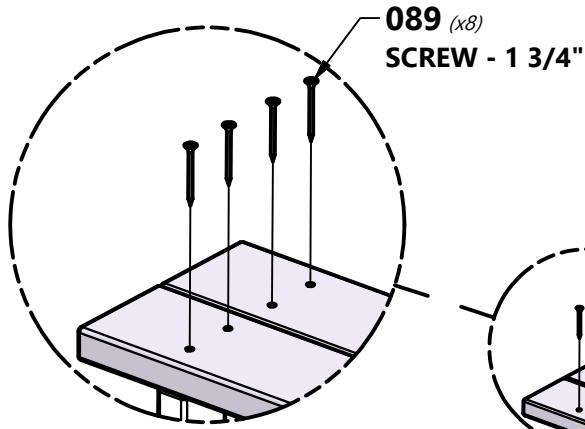

089 (x8)
SCREW - 1 3/4"

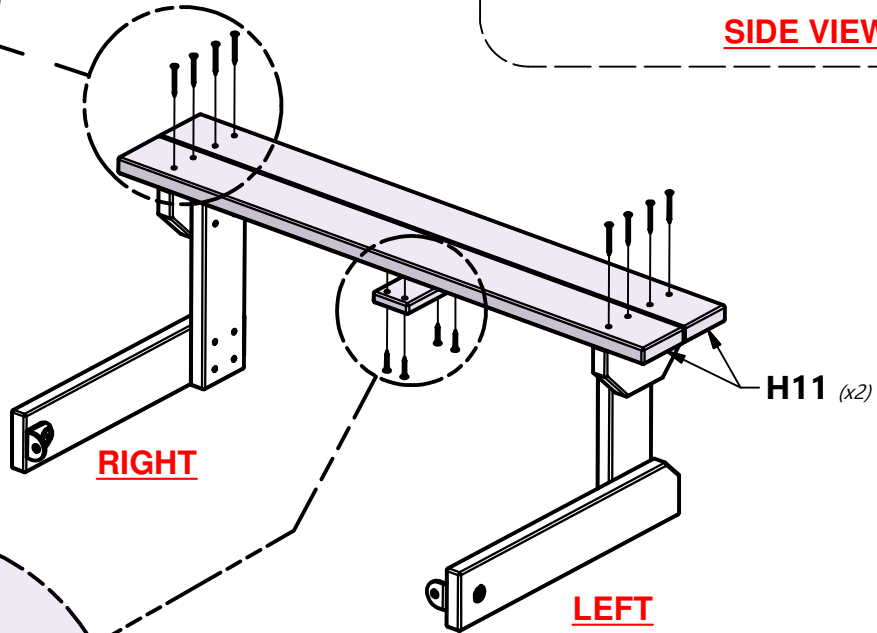

**CENTER BENCH SEAT
BOARDS ON BENCH
SUPPORTS, AS SHOWN.**

SIDE VIEW

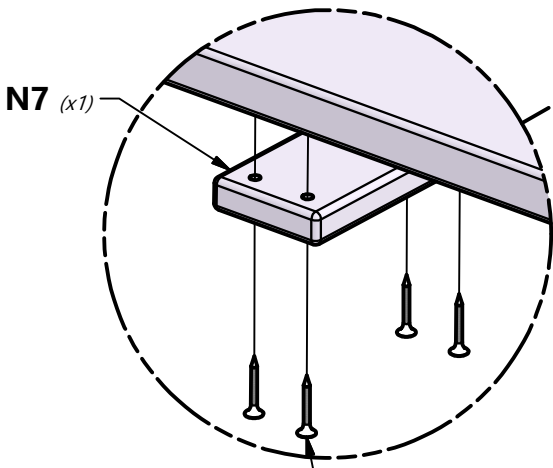

N7 (x1)

088 (x4)
SCREW - 1 1/8"

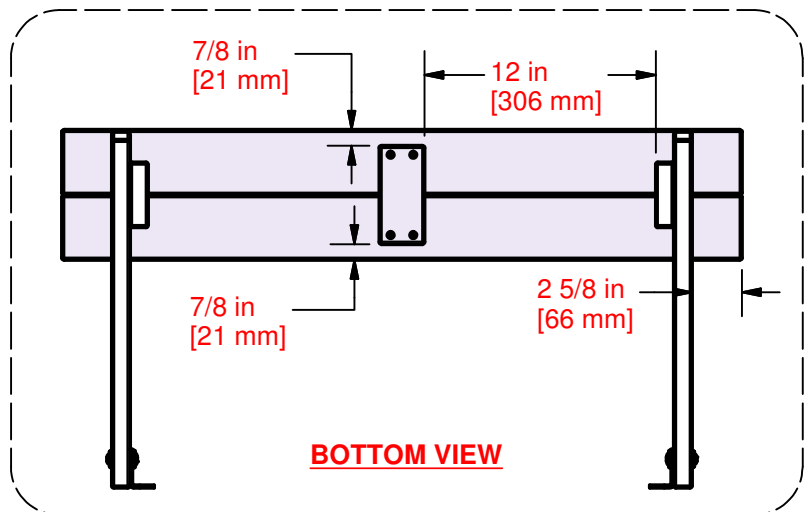

BOTTOM VIEW

STEP 1 - DOOR ASSEMBLY

QTY	PART NUMBER	DESCRIPTION
36	H100088	SCREW PFH 8x1-1/8"



L7 | DOOR BOARD - W4L14569
(x1) | 5/8"x4 3/8"x35" (16x110x890)



M24 | DOOR BOARD - W4L14594
(x2) | 5/8"x3 3/8"x21 1/4" (16x86x540)



L8 | DOOR BOARD - W4L14570
(x1) | 5/8"x4 3/8"x35" (16x110x890)



M23 | DOOR BOARD - W4L14593
(x2) | 5/8"x3 3/8"x35 3/4" (16x86x908)



O1 | DOOR CLEAT - W4L14609
(x3) | 5/8"x1 3/8"x21" (16x34x534)



M25 | DOOR BOARD - W4L14595
(x2) | 5/8"x3 3/8"x6 1/4" (16x86x160)

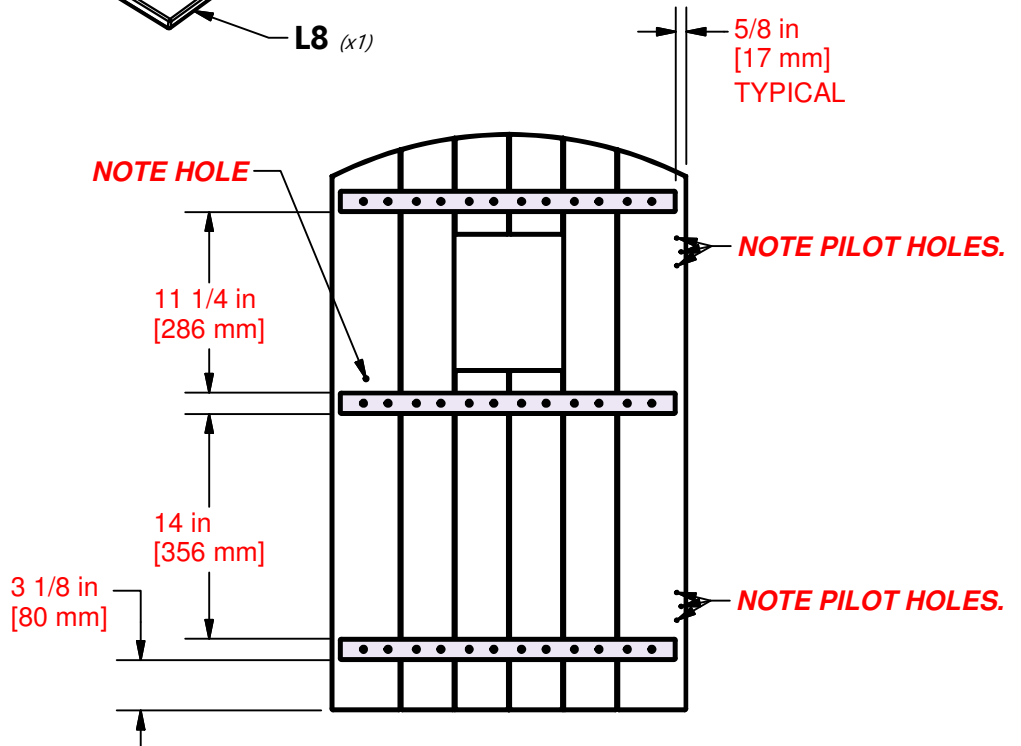
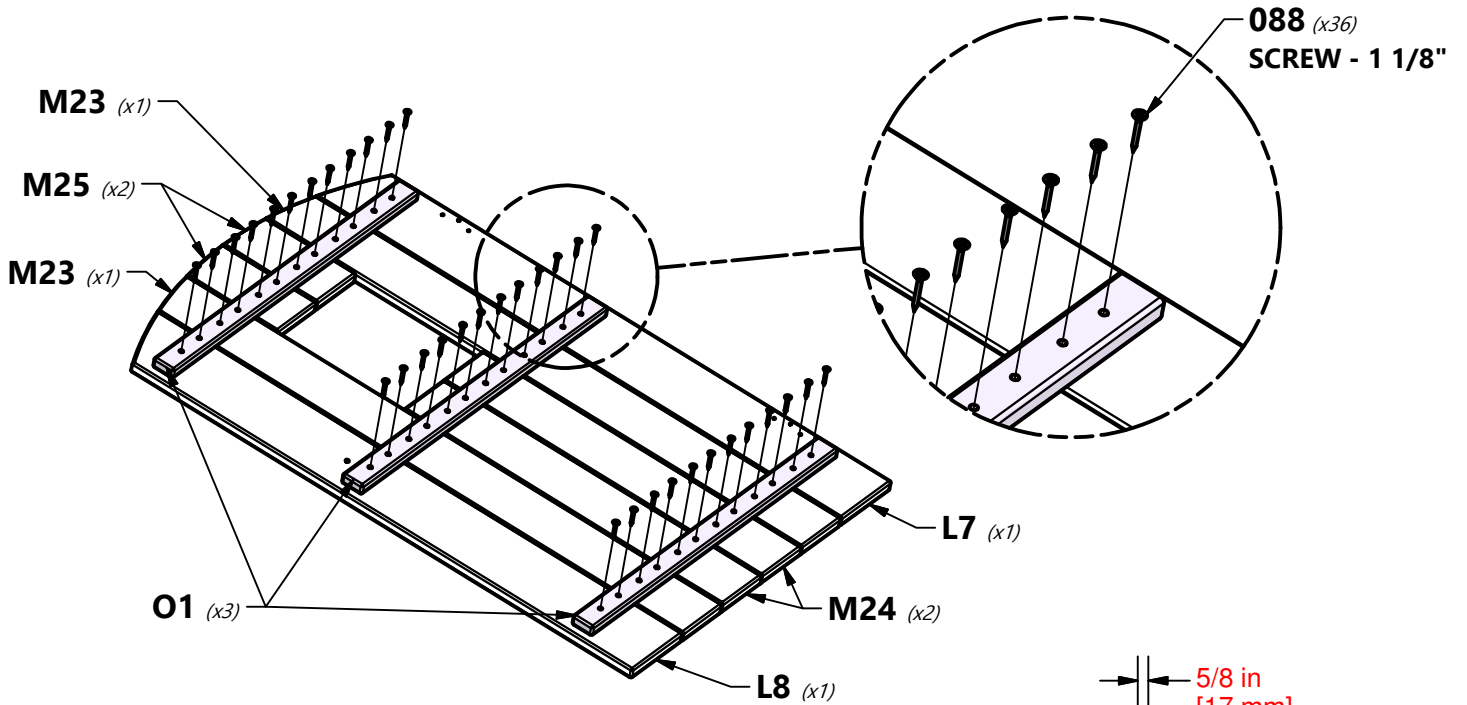

STEP 2 - DOOR ASSEMBLY

QTY	PART NUMBER	DESCRIPTION
4	H100070	SCREW PWH 8x3/4

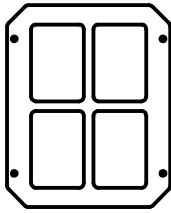

A100014
(x1) | **PLASTIC WINDOW WHITE**

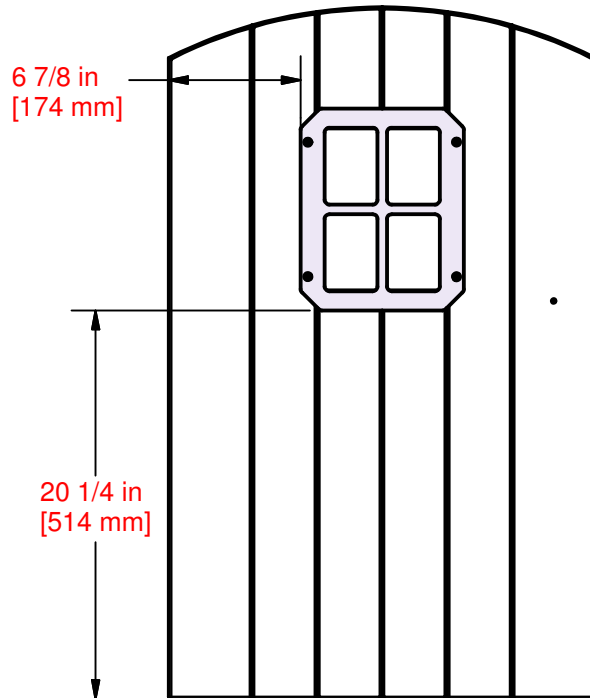
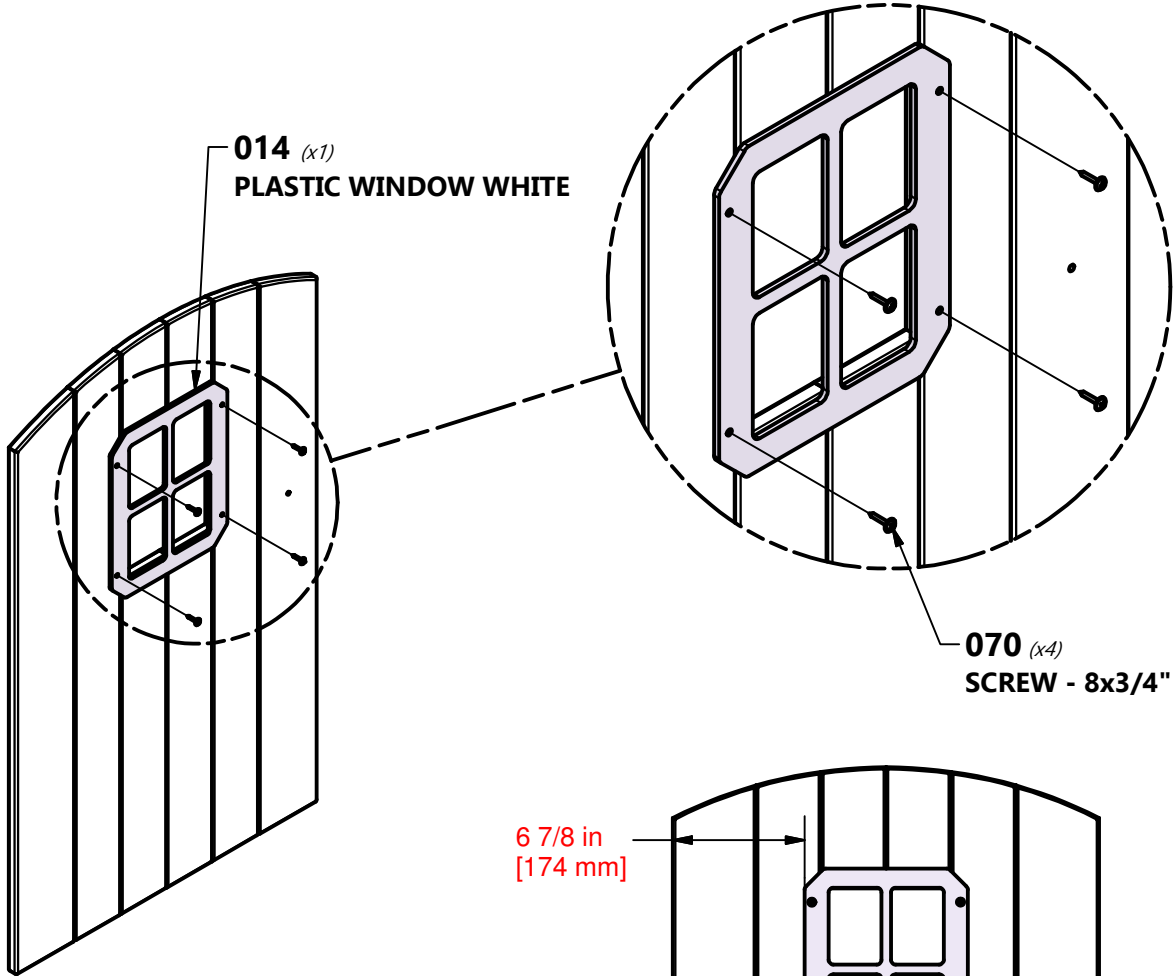

STEP 3 - DOOR ASSEMBLY

QTY	PART NUMBER	DESCRIPTION
1	H100088	SCREW PFH 8x1-1/8"
6	H100624	SCREW PFH 6x5/8" BLK

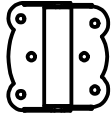

A4M00624
(x2) | HINGE (DOOR, SPRING LOADED)

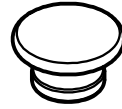

A6P00122
(x1) | KNOB - LT BROWN

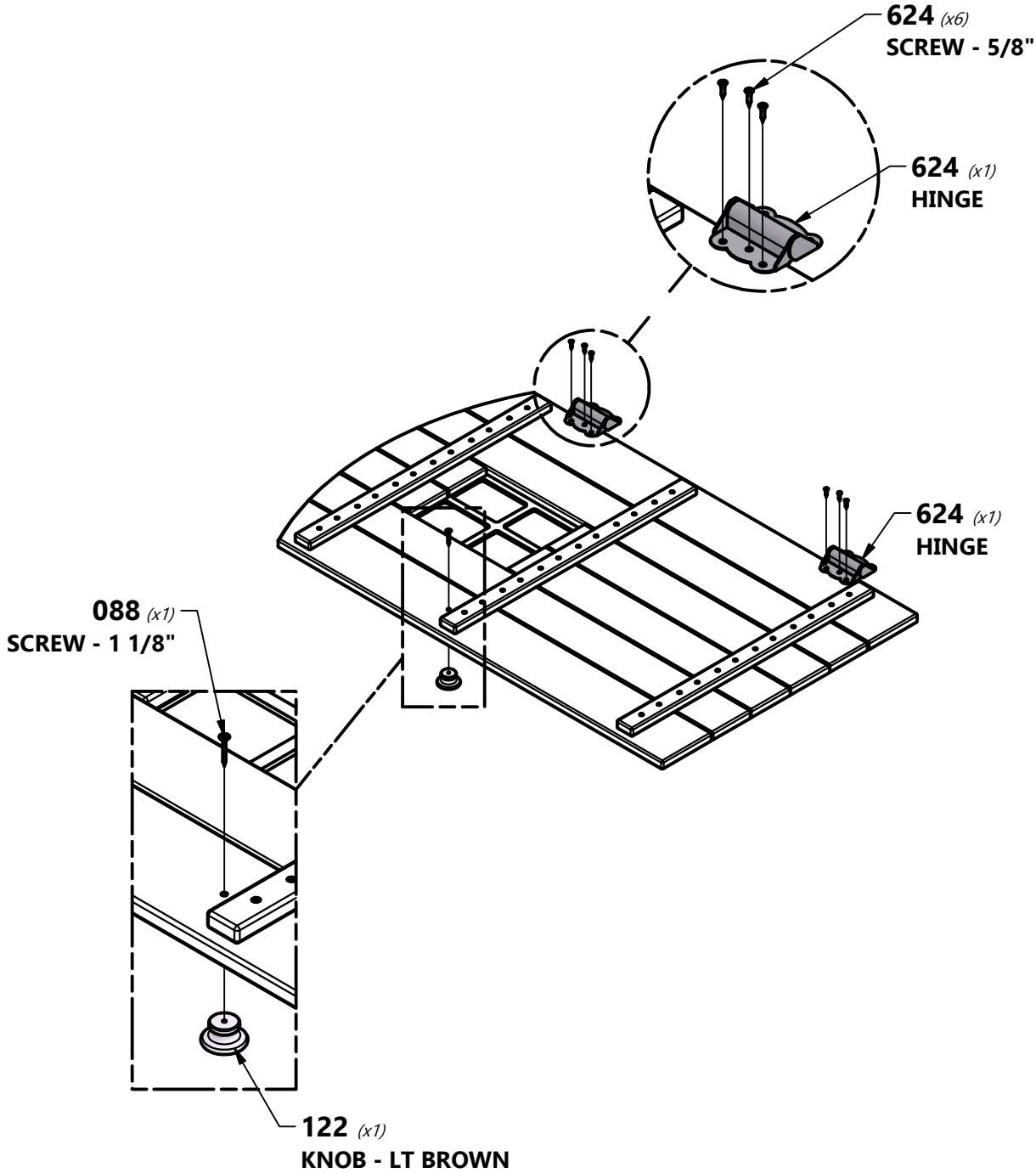

STEP 1 - MONKEY BAR ASSEMBLY



E71 | MONKEY BAR RAIL - W4L06929
(x1) | 1 3/8"x3 3/8"x60 5/8" (36x86x1539)



A100053 | L BRACKET
(x1) | 54x67 - GRN

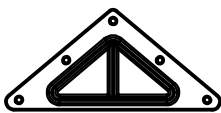

A100294 | TRIANGLE
(x1) | PLATE 100° 5
HOLE

QTY	PART NUMBER	DESCRIPTION
3	H100379	T-NUT 5/16 BLK
3	H100407	BOLT WH 5/16x1 1/2 BLK
1	H100457	BOLT WH 5/16x2 BLK
1	H100478	WASHER FLAT 8x27 BLK
1	H100479	NUT LOCK 5/16 BLK

TIP:
INSTALL T-NUTS IN WOOD FIRST

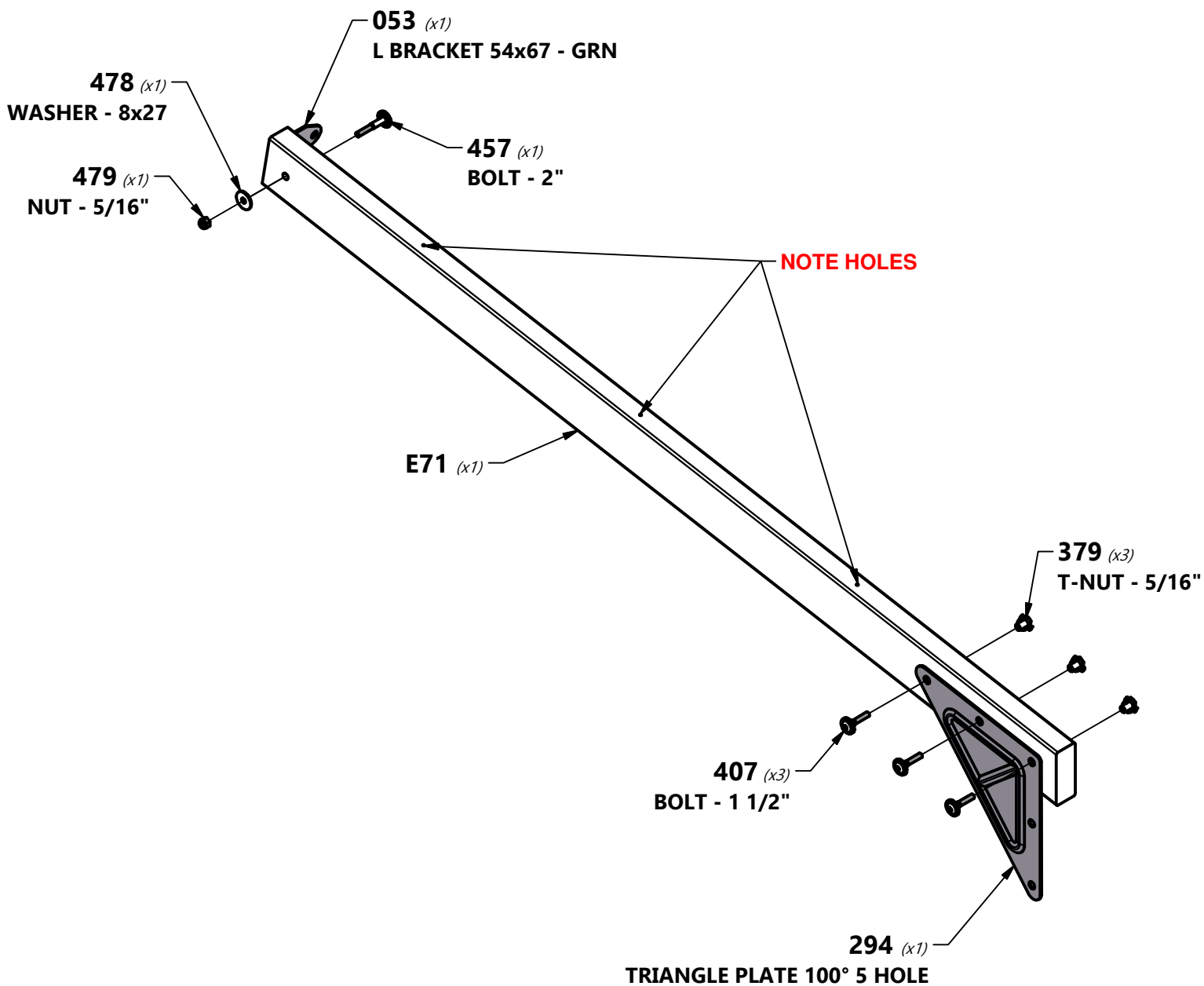

STEP 2 - MONKEY BAR ASSEMBLY



E71 | MONKEY BAR RAIL - W4L06929
(x1) | 1 3/8"x3 3/8"x60 5/8" (36x86x1539)



A100053 | L BRACKET
(x1) | 54x67 - GRN

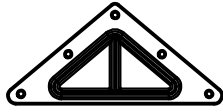

A100294 | TRIANGLE
(x1) | PLATE 100° 5
HOLE

QTY	PART NUMBER	DESCRIPTION
3	H100379	T-NUT 5/16 BLK
3	H100407	BOLT WH 5/16x1 1/2 BLK
1	H100457	BOLT WH 5/16x2 BLK
1	H100478	WASHER FLAT 8x27 BLK
1	H100479	NUT LOCK 5/16 BLK

TIP:
INSTALL T-NUTS IN WOOD FIRST

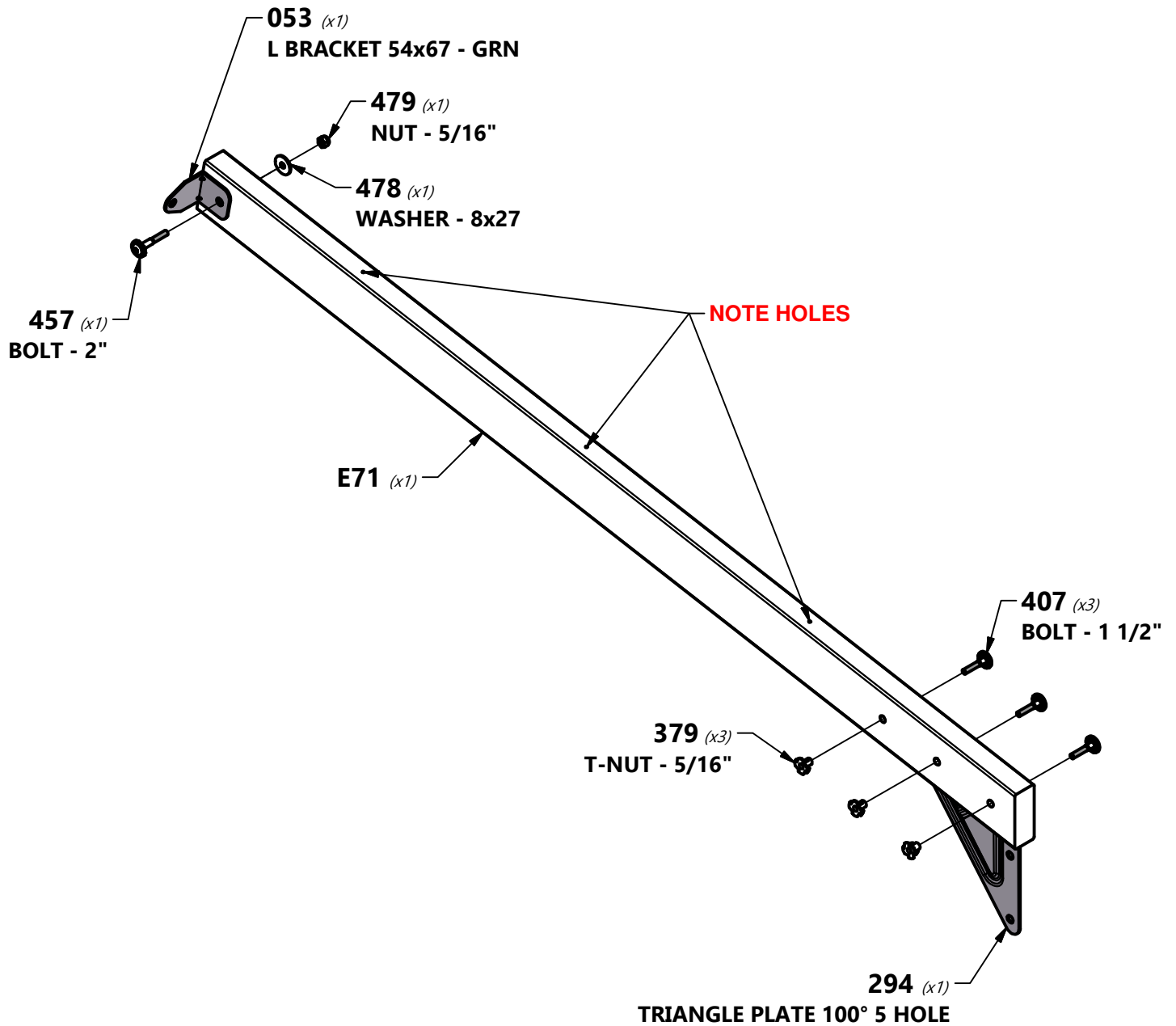

STEP 3 - MONKEY BAR ASSEMBLY



E6 | MONKEY BAR UPRIGHT - W4L14536
 (x1) | 1 3/8"x3 3/8"x71 3/8" (36x86x1812)

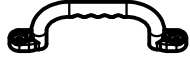

A100028 | HAND GRIP GREEN PLASTIC
 (x1)

QTY	PART NUMBER	DESCRIPTION
2	H100379	T-NUT 5/16 BLK
2	H100407	BOLT WH 5/16x1 1/2 BLK
2	H100403	LAG SCREW WH 1/4x1-1/2 BLK
2	H100405	WASHER LOCK EXT 6x15 BLK

TIP:
INSTALL T-NUTS IN WOOD FIRST

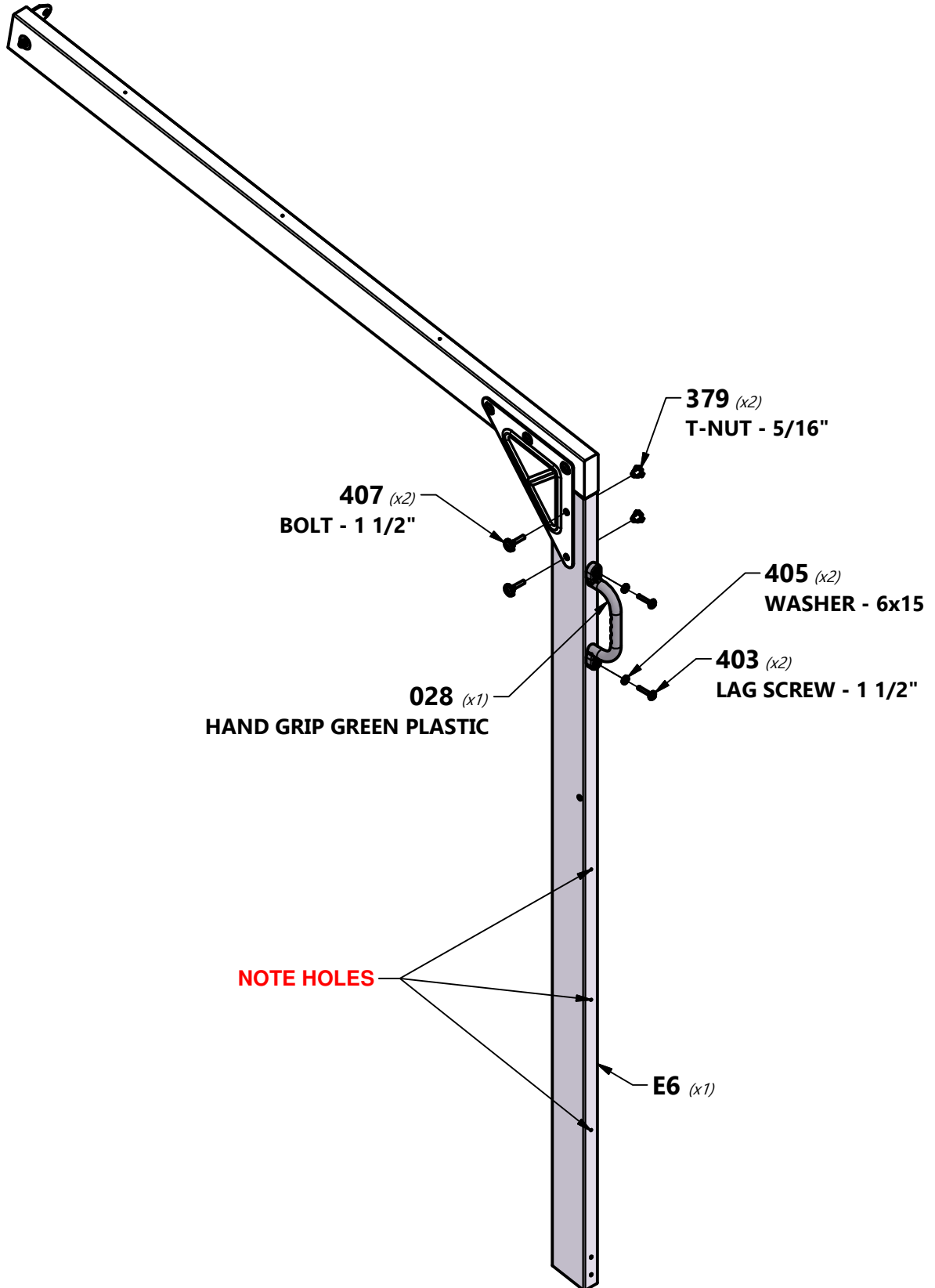

STEP 4 - MONKEY BAR ASSEMBLY



E6 | MONKEY BAR UPRIGHT - W4L14536
 (x1) | 1 3/8"x3 3/8"x71 3/8" (36x86x1812)



A100028 | HAND GRIP GREEN PLASTIC
 (x1)

QTY	PART NUMBER	DESCRIPTION
2	H100379	T-NUT 5/16 BLK
2	H100407	BOLT WH 5/16x1 1/2 BLK
2	H100403	LAG SCREW WH 1/4x1-1/2 BLK
2	H100405	WASHER LOCK EXT 6x15 BLK

TIP:
INSTALL T-NUTS IN WOOD FIRST

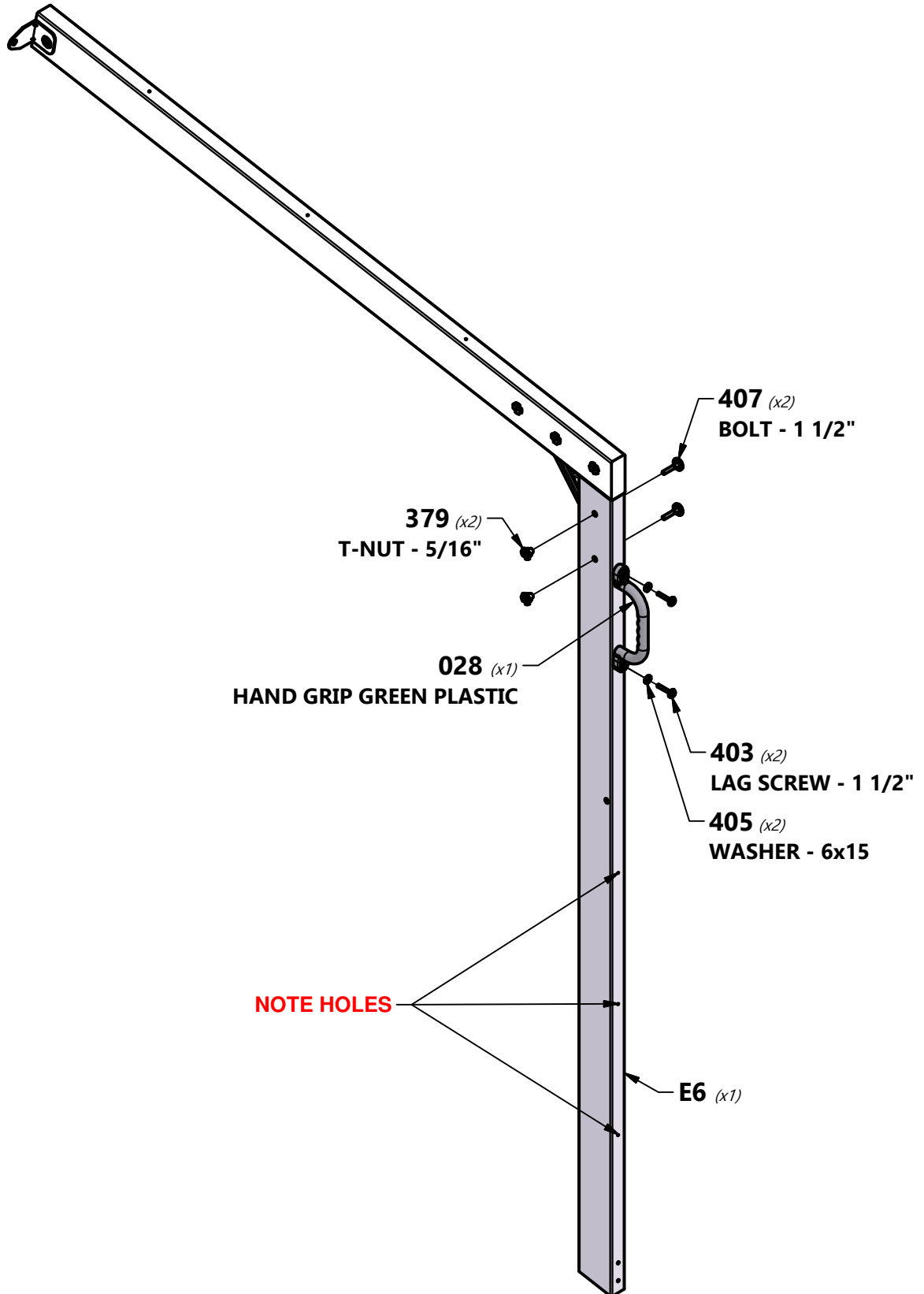

STEP 5 - MONKEY BAR ASSEMBLY

QTY	PART NUMBER	DESCRIPTION
12	H100403	LAG SCREW WH 1/4x1-1/2 BLK

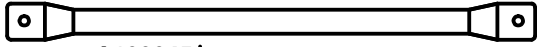

A100045
(x6) | METAL RUNG 559 GREEN

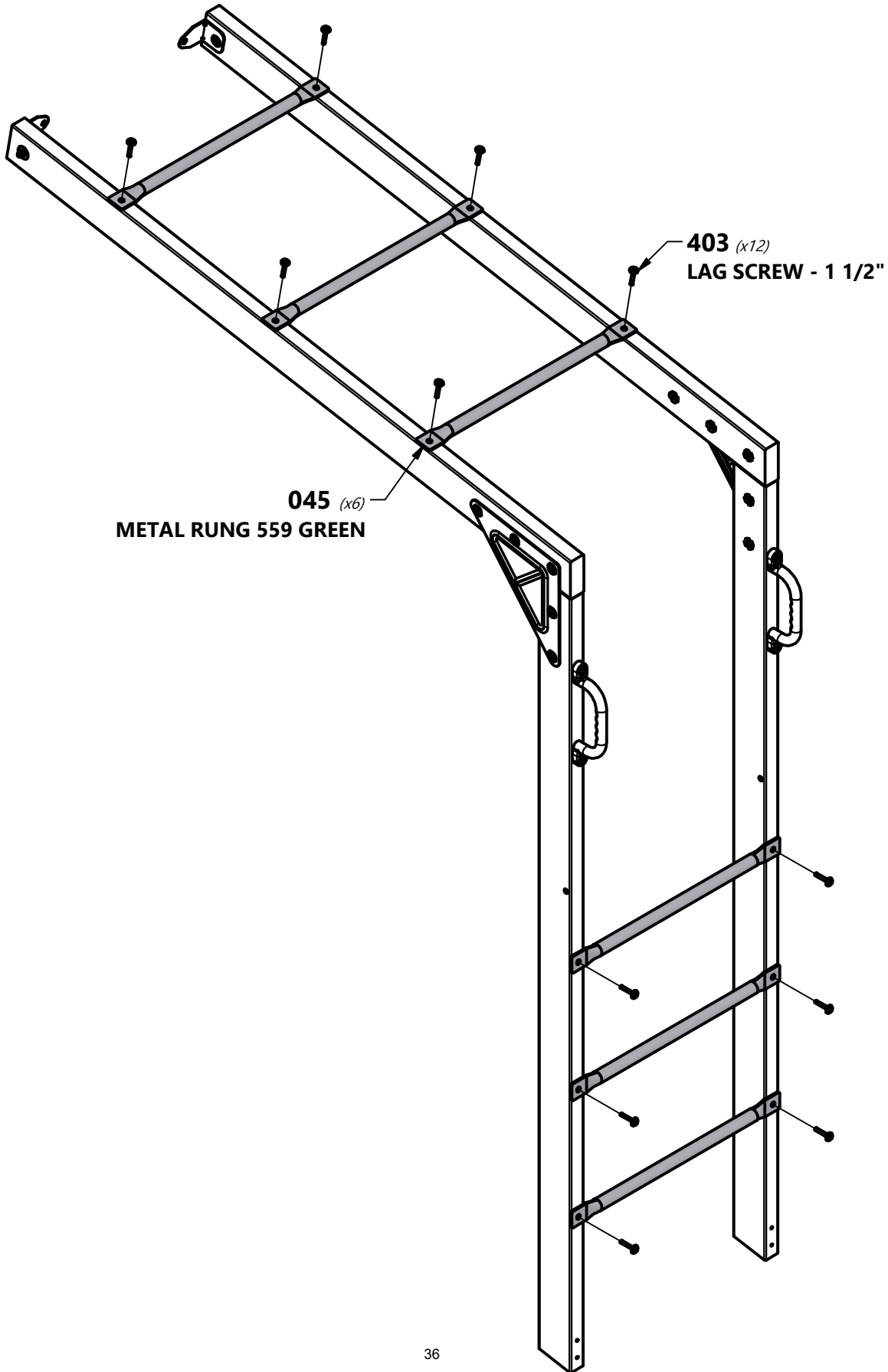

STEP 6 - MONKEY BAR ASSEMBLY



H3 MONKEY BAR GROUND BOARD - W4L14545
 (x1) 1"x3 3/8"x70 3/8" (24x86x1786)



H2 MONKEY BAR BRACE - W4L14544
 (x2) 1"x3 3/8"x51 1/2" (24x86x1308 mm)

QTY	PART NUMBER	DESCRIPTION
8	H100198	WASHER LOCK EXT 8x19 BLK
4	H100378	BOLT WH 5/16x1 3/4 BLK
6	H100379	T-NUT 5/16 BLK
4	H100458	LAG SCREW WH 5/16x2 BLK
2	H100472	BOLT HEX 5/16x2-3/4 BLK
2	H100473	WASHER LOCK INT 8x15 BLK
2	H100474	WASHER FLAT 9x18 BLK

TIP:
INSTALL T-NUTS IN WOOD FIRST

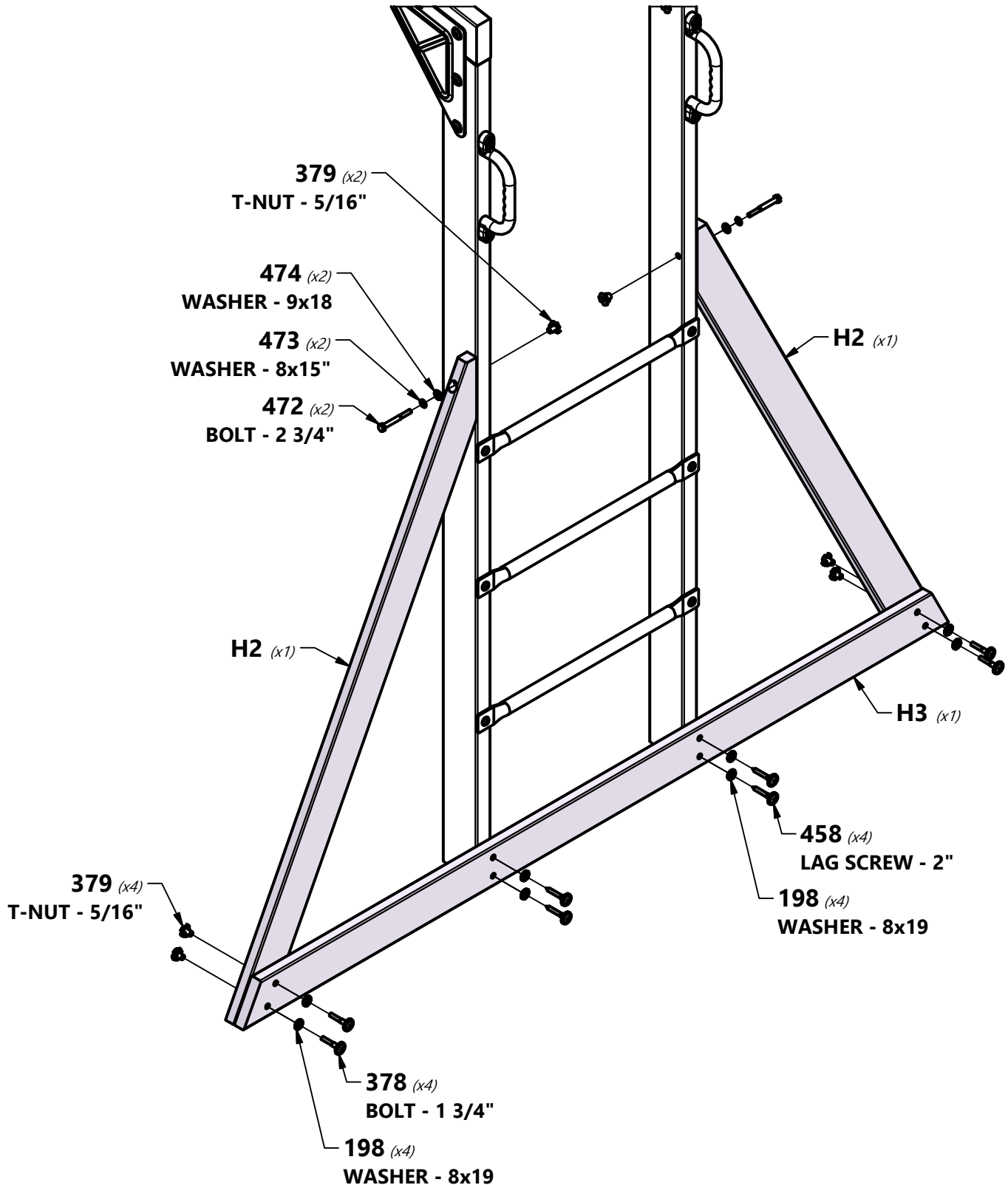

STEP 1 - SWING BEAM ASSEMBLY

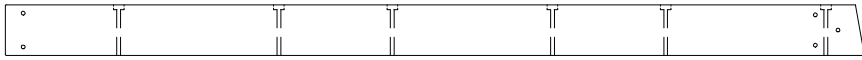

SB74 | SWING BEAM EXTENDED - W4L16477
(x1) | 2"x5 1/4"x89 1/2" (50x134x2274)

QTY	PART NUMBER	DESCRIPTION
3	H100192	NUT BARREL WH 5/16x7/8 BLK
3	H100378	BOLT WH 5/16x1 3/4 BLK
2	H100472	BOLT HEX 5/16x2-3/4 BLK
4	H100478	WASHER FLAT 8x27 BLK
2	H100479	NUT LOCK 5/16 BLK

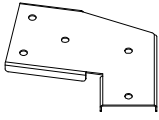

A100325 | SWING BEAM
EXTENSION
BRACKET-LEFT
(x1)

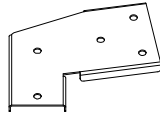

A100326 | SWING BEAM
EXTENSION
BRACKET-RIGHT
(x1)

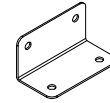

A100140 | L BRACKET
(x2) | 66x66x127

TIP:
LEAVE 378 BOLTS HAND TIGHT AT THIS TIME

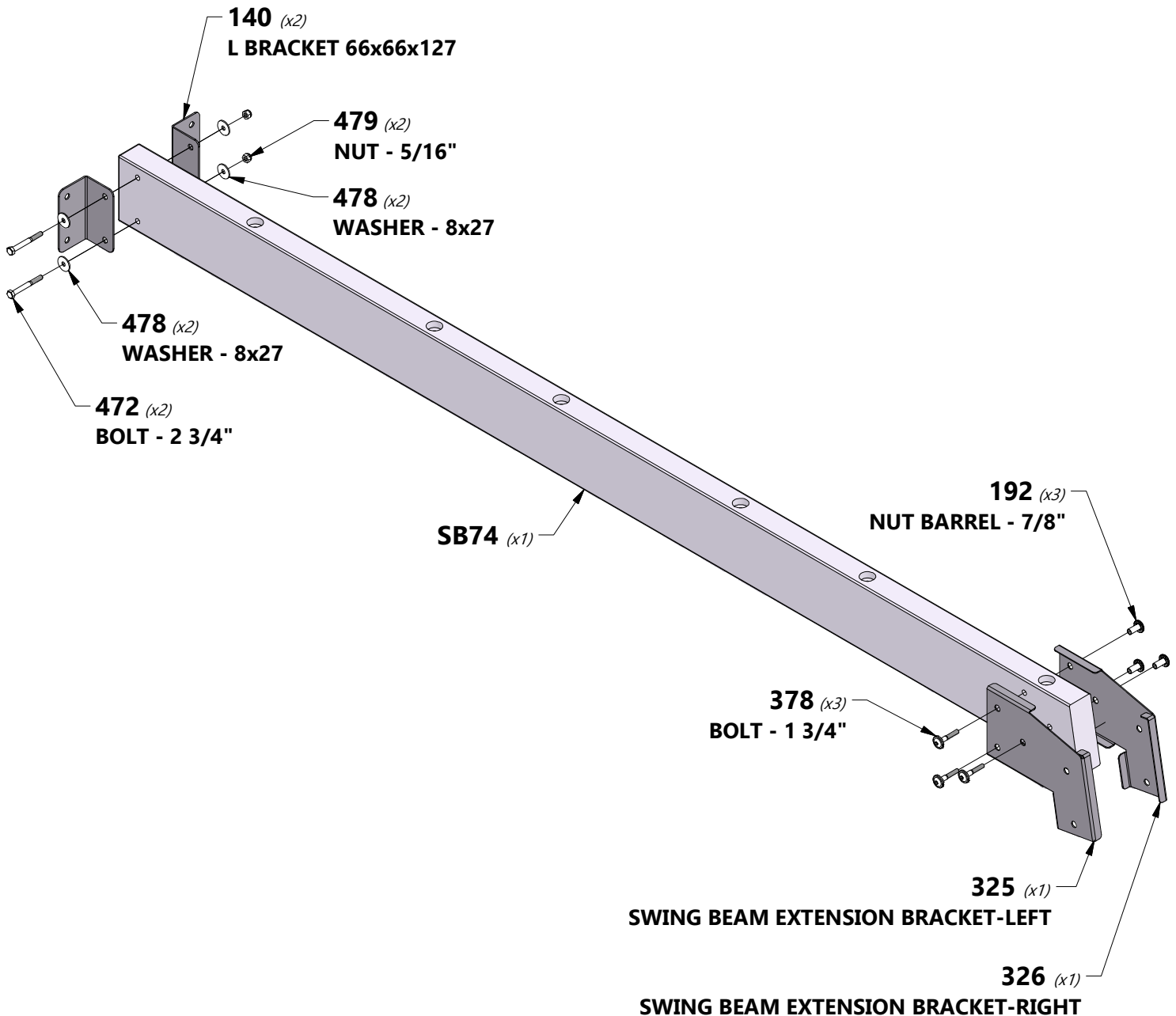

STEP 2 - SWING BEAM ASSEMBLY

QTY	PART NUMBER	DESCRIPTION
6	H100379	T-NUT 5/16 BLK
4	H100407	BOLT WH 5/16x1 1/2 BLK
2	H100503	BOLT WH 5/16x3-1/2 BLK

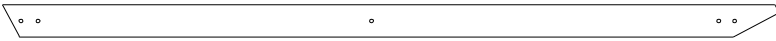

E77 | ANGLE BRACE - W4L14540
(x2) | 1 3/8"x3 3/8"x81" (36x86x2056)



W71 | SWING BEAM SUPPORT - W4L14615
(x1) | 2"x3 3/8"x50 3/8" (50x86x1280)

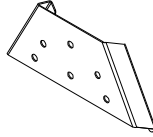

A4M01169 | A-FRAME BRACKET
(x1)

TIP:
INSTALL T-NUTS IN WOOD FIRST

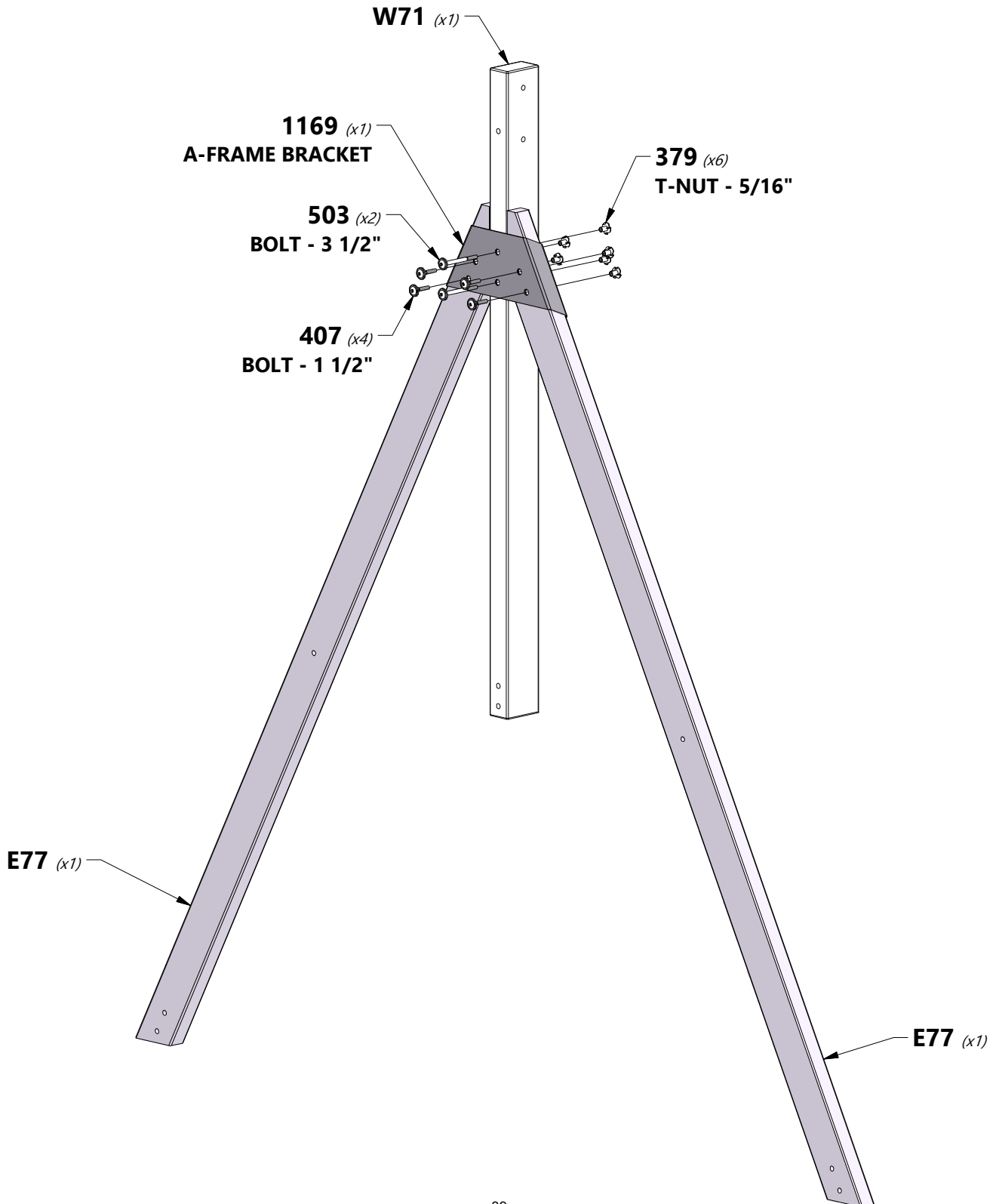

STEP 3 - SWING BEAM ASSEMBLY

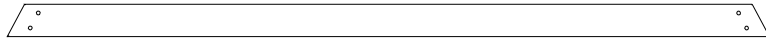

H80 | GROUND BOARD - W4L14552
(x1) | 1"x3 3/8"x79 1/2" (24x86x2018)

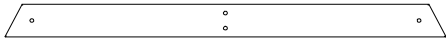

E50 | END SUPPORT - W4L14538
(x1) | 1 1/2"x3 1/2"x46" (36x86x1168)

QTY	PART NUMBER	DESCRIPTION
2	H100195	BOLT WH 5/16x2-3/4 BLK
8	H100198	WASHER LOCK EXT 8x19 BLK
4	H100205	BOLT WH 5/16x2-1/4 BLK
8	H100379	T-NUT 5/16 BLK
2	H100480	BOLT WH 5/16x4 3/4 BLK

TIP:
INSTALL T-NUTS IN WOOD FIRST

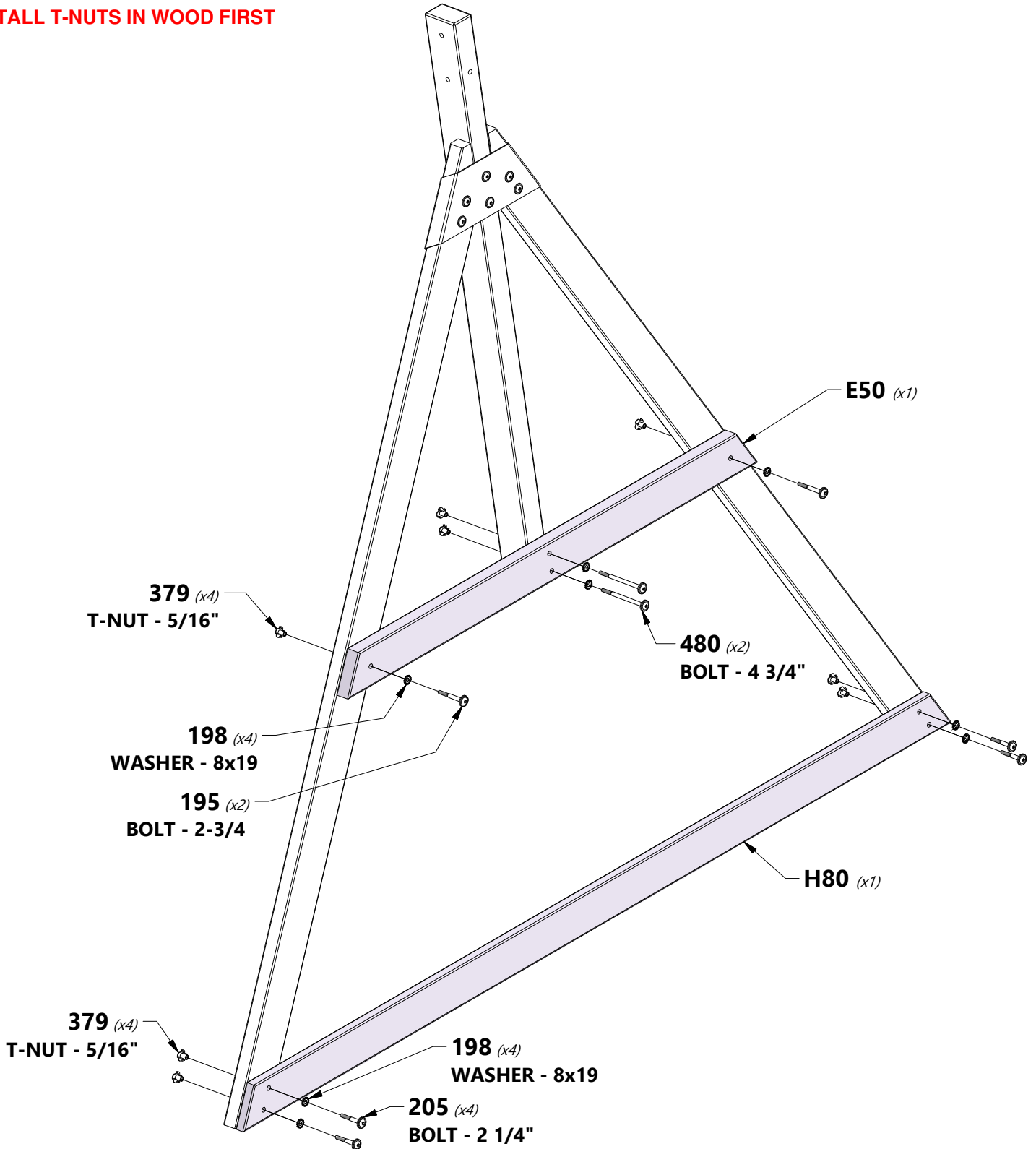

STEP 4 - SWING BEAM ASSEMBLY

QTY	PART NUMBER	DESCRIPTION
2	H100192	NUT BARREL WH 5/16x7/8 BLK
1	H100193	NUT BARREL WH 5/16x1-1/2 BLK
1	H100194	BOLT WH 5/16x2-1/2 BLK
2	H100378	BOLT WH 5/16x1 3/4 BLK

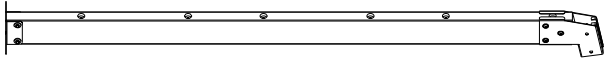

(x1) SWING BEAM SUBASSEMBLY

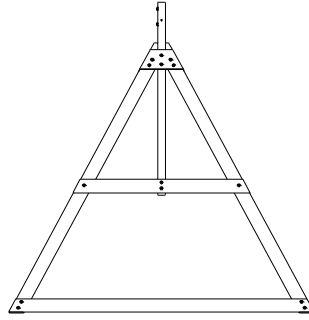

(x1) SWING BEAM END SUBASSEMBLY

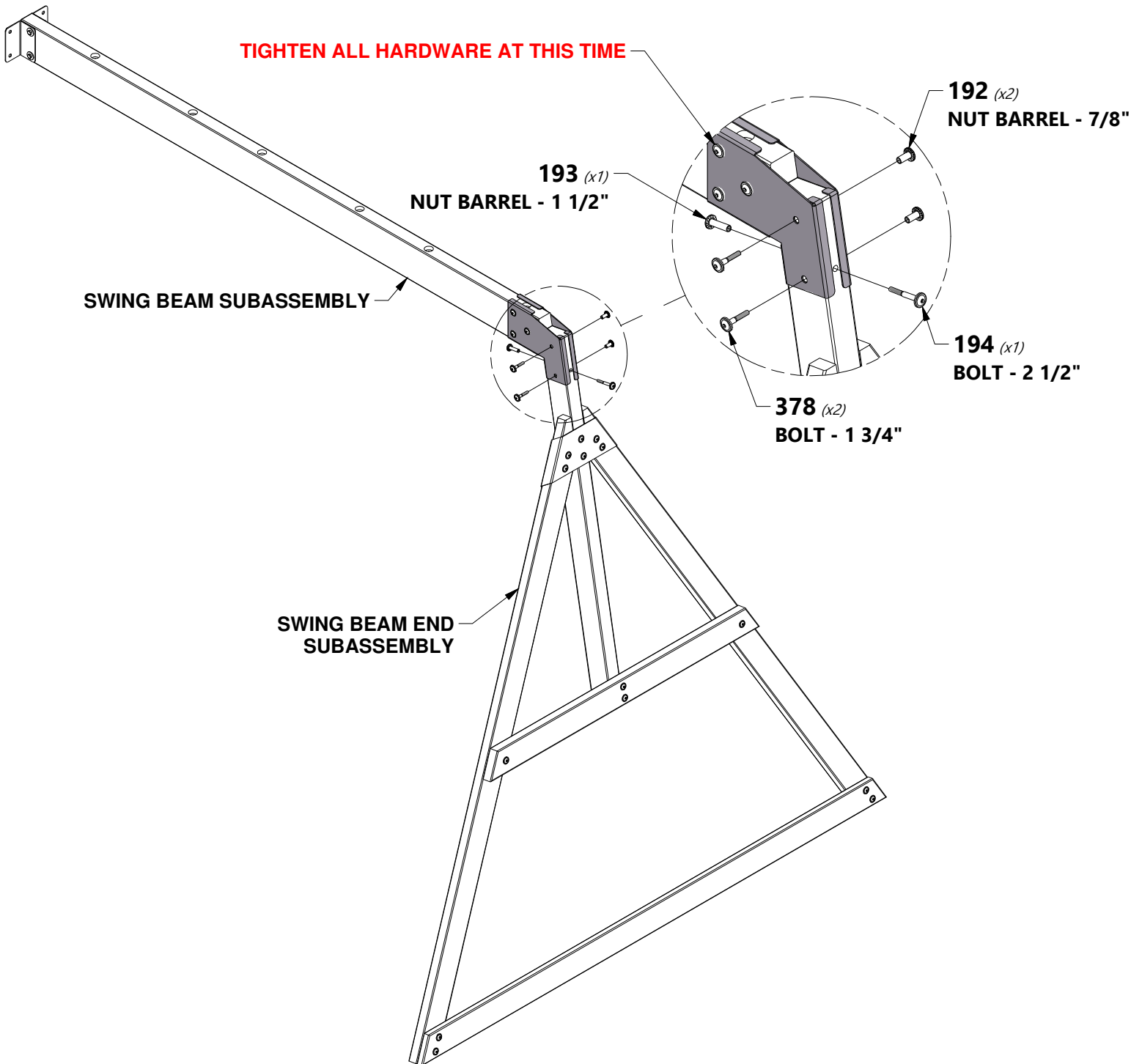

STEP 5 - SWING BEAM ASSEMBLY

QTY	PART NUMBER	DESCRIPTION
6	H100103	WASHER SAFETY 17x30
6	H100105	WASHER FLAT 8x27
6	H100110	NUT LOCK 5/16

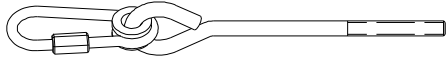

H100099 | 9 1/2" SWING HANGER QUICK LINK
(x6)

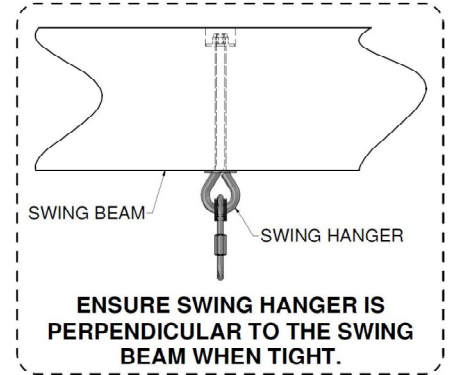
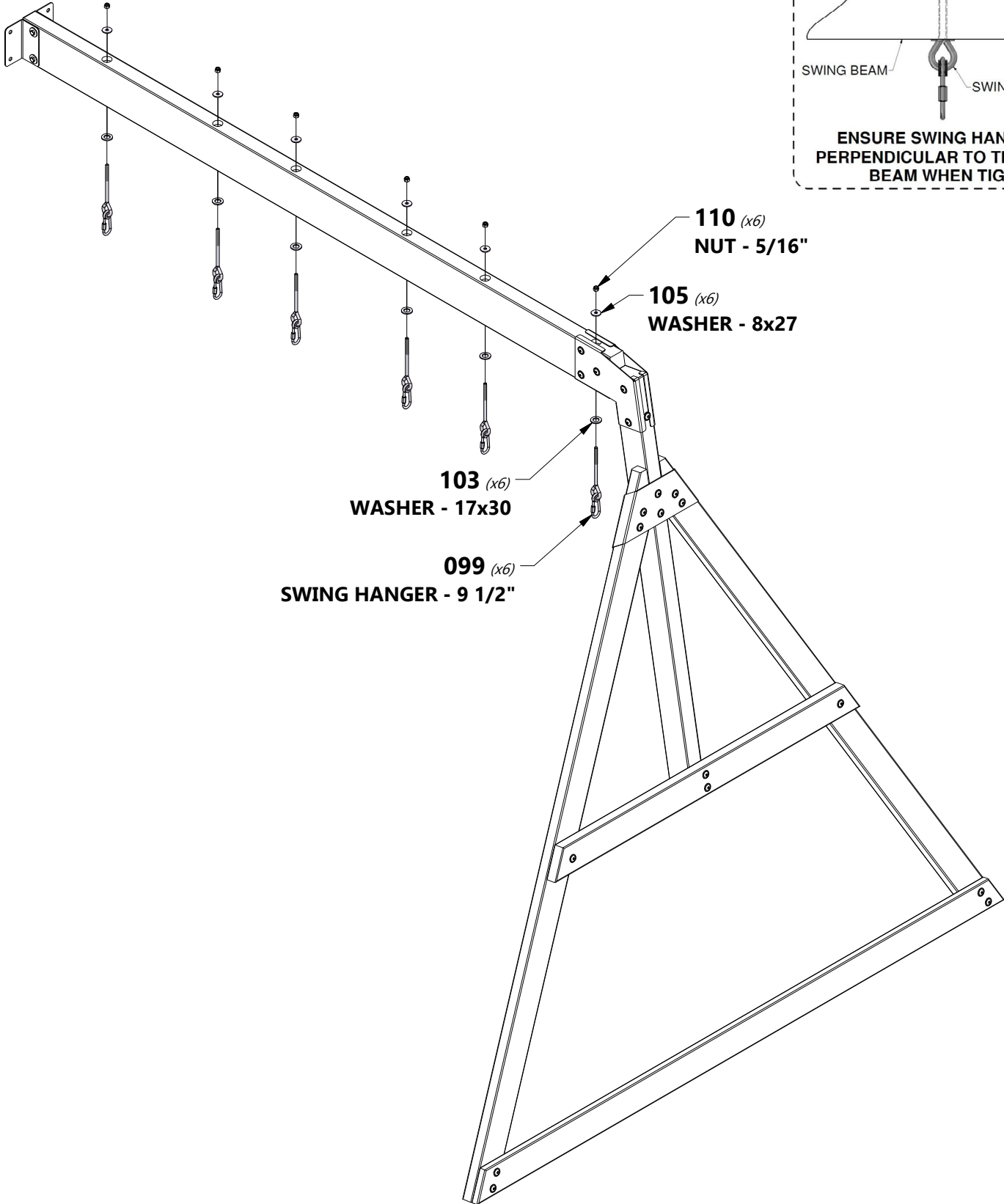

STEP 6 - SWING BEAM ASSEMBLY

QTY	PART NUMBER	DESCRIPTION
4	H100128	SCREW PWH 8x5/8



A100164
(x1) | **BYD ID TAG (LARGE) AGES 3-10**

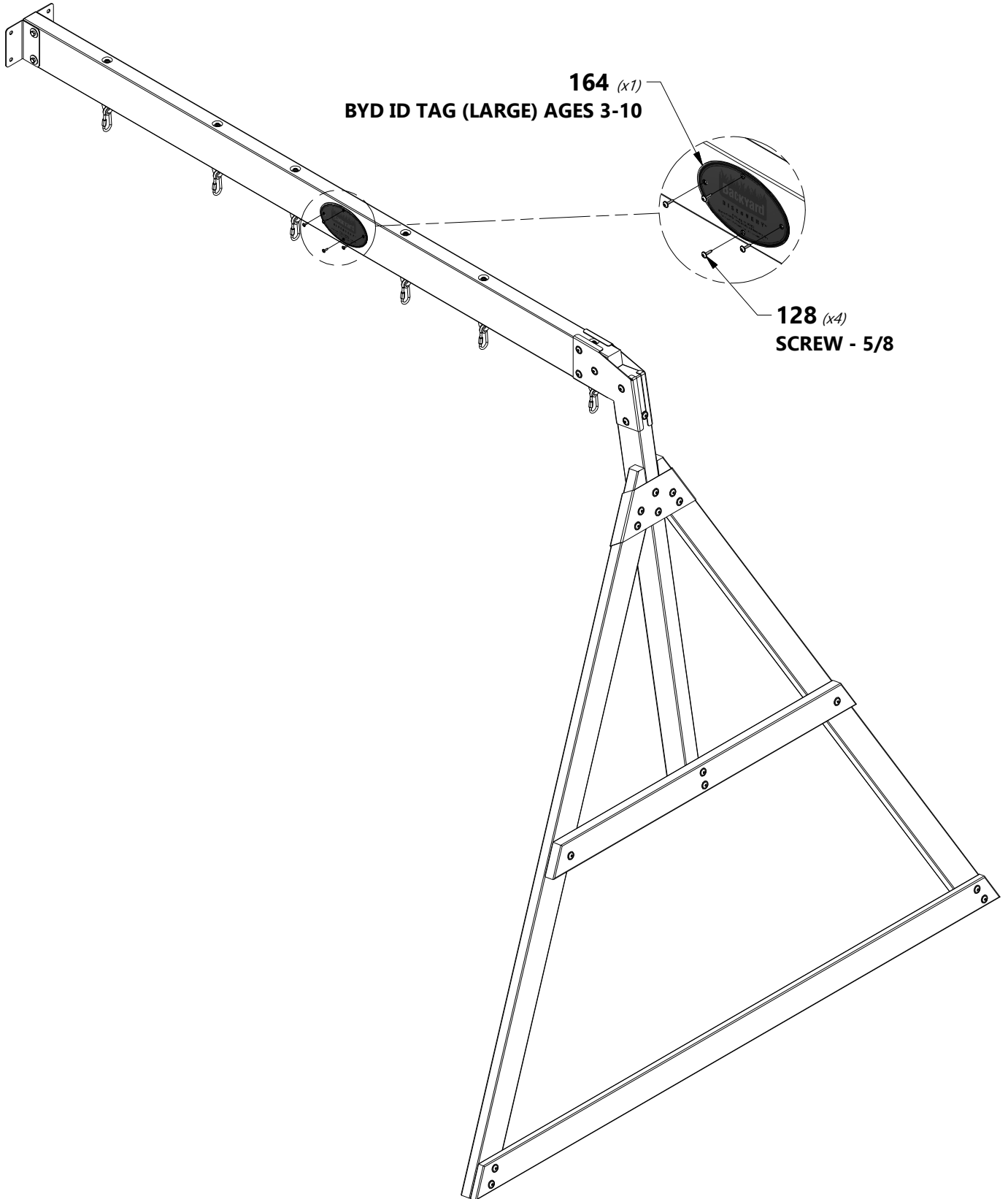

STEP 1A - FORT ASSEMBLY

QTY	PART NUMBER	DESCRIPTION
14	H100198	WASHER LOCK EXT 8x19 BLK
4	H100205	BOLT WH 5/16x2-1/4 BLK
12	H100379	T-NUT 5/16 BLK
8	H100457	BOLT WH 5/16x2 BLK
2	H100471	LAG SCREW WH 5/16x1-1/2 BLK

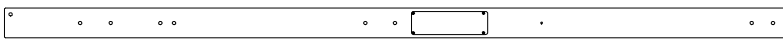

E1 | UPRIGHT - W2A03132
(x1) | 1 3/8"x3 3/8"x89 1/2" (36x86x2274)

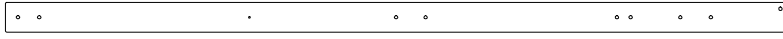

E3 | UPRIGHT - W4L14533
(x1) | 1 3/8"x3 3/8"x89 1/2" (36x86x2274)

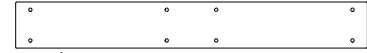

G1 | SWING BEAM MOUNT - W4L14542
(x1) | 1"x5 1/4"x40 3/8" (24x134x1024)



N1 | SAFETY BOARD - W4L14602
(x1) | 5/8"x2 3/8"x40 3/8" (16x60x1024)



M7 | FLOOR SUPPORT - W4L14577
(x1) | 5/8"x3 3/8"x40 3/8" (16x86x1024)

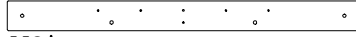

M8 | FLOOR SUPPORT - W4L14578
(x1) | 5/8"x3 3/8"x40 3/8" (16x86x1024)



L4 | WALL RAIL - W4L14566
(x1) | 5/8"x4 3/8"x40 3/8" (16x112x1024)

TIP:
INSTALL T-NUTS IN WOOD FIRST

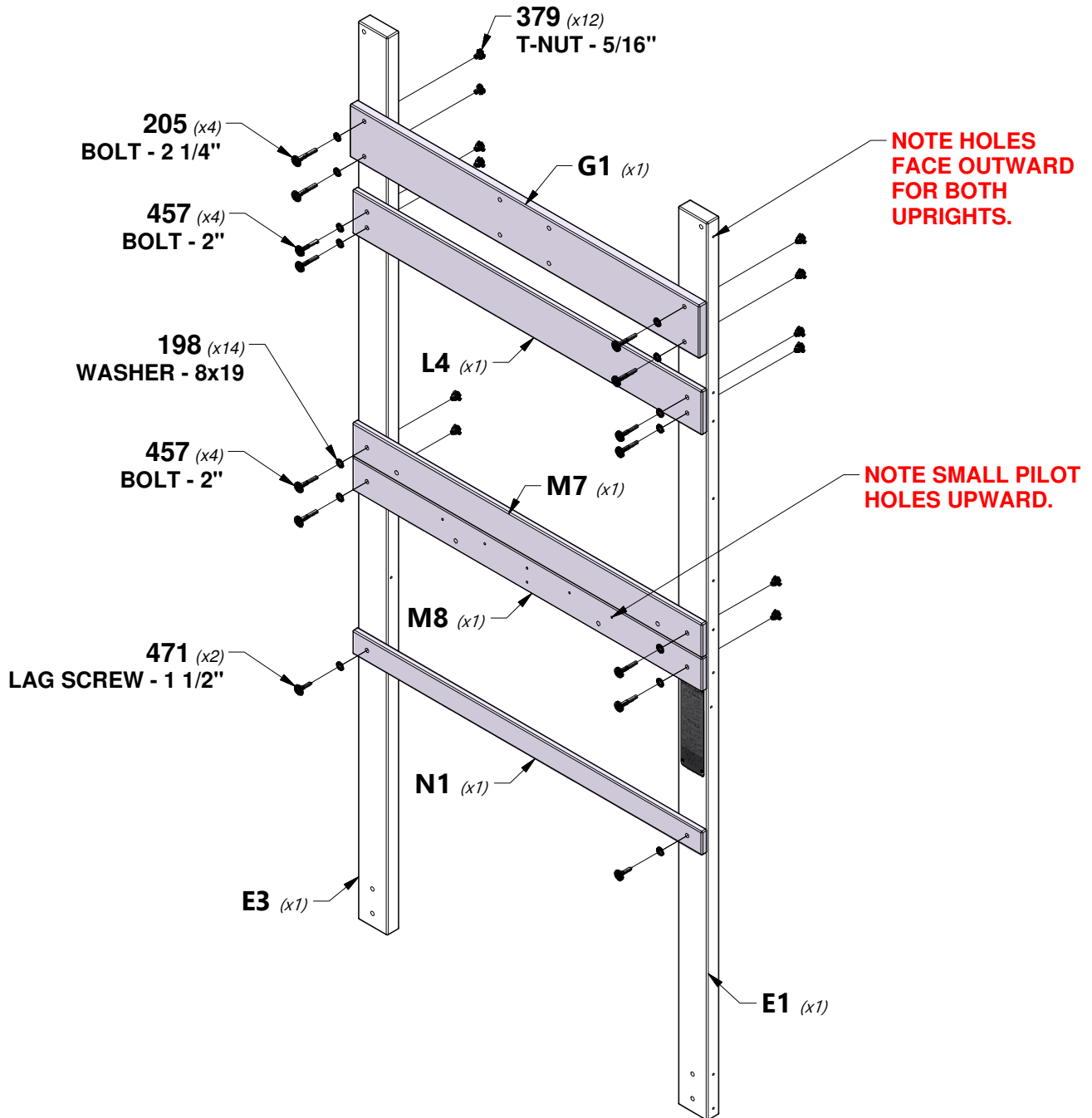

STEP 1B - FORT ASSEMBLY

QTY	PART NUMBER	DESCRIPTION
8	H100198	WASHER LOCK EXT 8x19 BLK
8	H100379	T-NUT 5/16 BLK
2	H100405	WASHER LOCK EXT 6x15 BLK
4	H100407	BOLT WH 5/16x1 1/2 BLK
4	H100457	BOLT WH 5/16x2 BLK
2	H100487	LAG SCREW WH 1/4x2 BLK



K4 | GROUND BOARD - W4L14560
(x1) | 5/8"x5 1/4"x78 1/4" (16x134x1986)

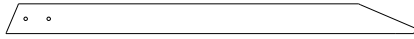

H6 | ANGLE BRACE - W4L14549
(x2) | 15/16"x3 3/8"x47" (24x86x1194)

TIP:
INSTALL T-NUTS IN WOOD FIRST

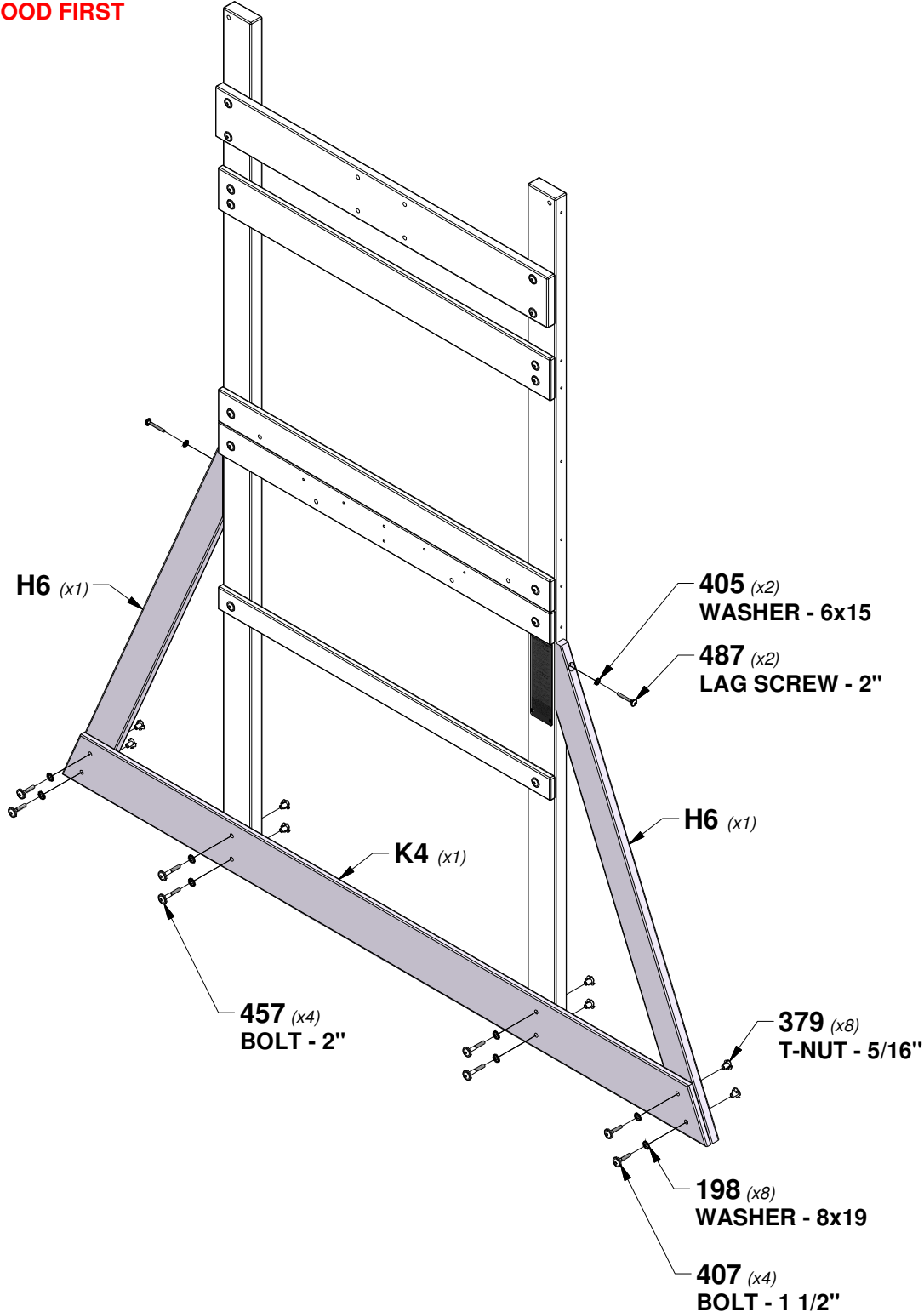

STEP 2 - FORT ASSEMBLY

QTY	PART NUMBER	DESCRIPTION
18	H100198	WASHER LOCK EXT 8x19 BLK
18	H100458	LAG SCREW WH 5/16x2 BLK



E2 | UPRIGHT - W4L14532
(x1) | 1 3/8"x3 3/8"x73 1/8" (36x86x1856)



E5 | UPRIGHT - W4L14535
(x1) | 1 3/8"x3 3/8"x73 1/8" (36x86x1856)



L1 | WALL RAIL - W4L14563
(x1) | 5/8"x4 3/8"x40 3/8" (16x112x1024)

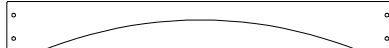

K3 | FLOOR SUPPORT - W4L14559
(x1) | 5/8"x5 1/4"x40 3/8" (16x134x1024)



K2 | GROUND BOARD - W4L14558
(x1) | 5/8"x5 1/4"x40 3/8" (16x134x1024)



M2 | FLOOR SUPPORT - W4L14572
(x2) | 5/8"x3 3/8"x40 3/8" (16x86x1024)

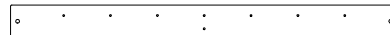

M3 | FLOOR SUPPORT - W4L14573
(x1) | 5/8"x3 3/8"x40 3/8" (16x86x1024)

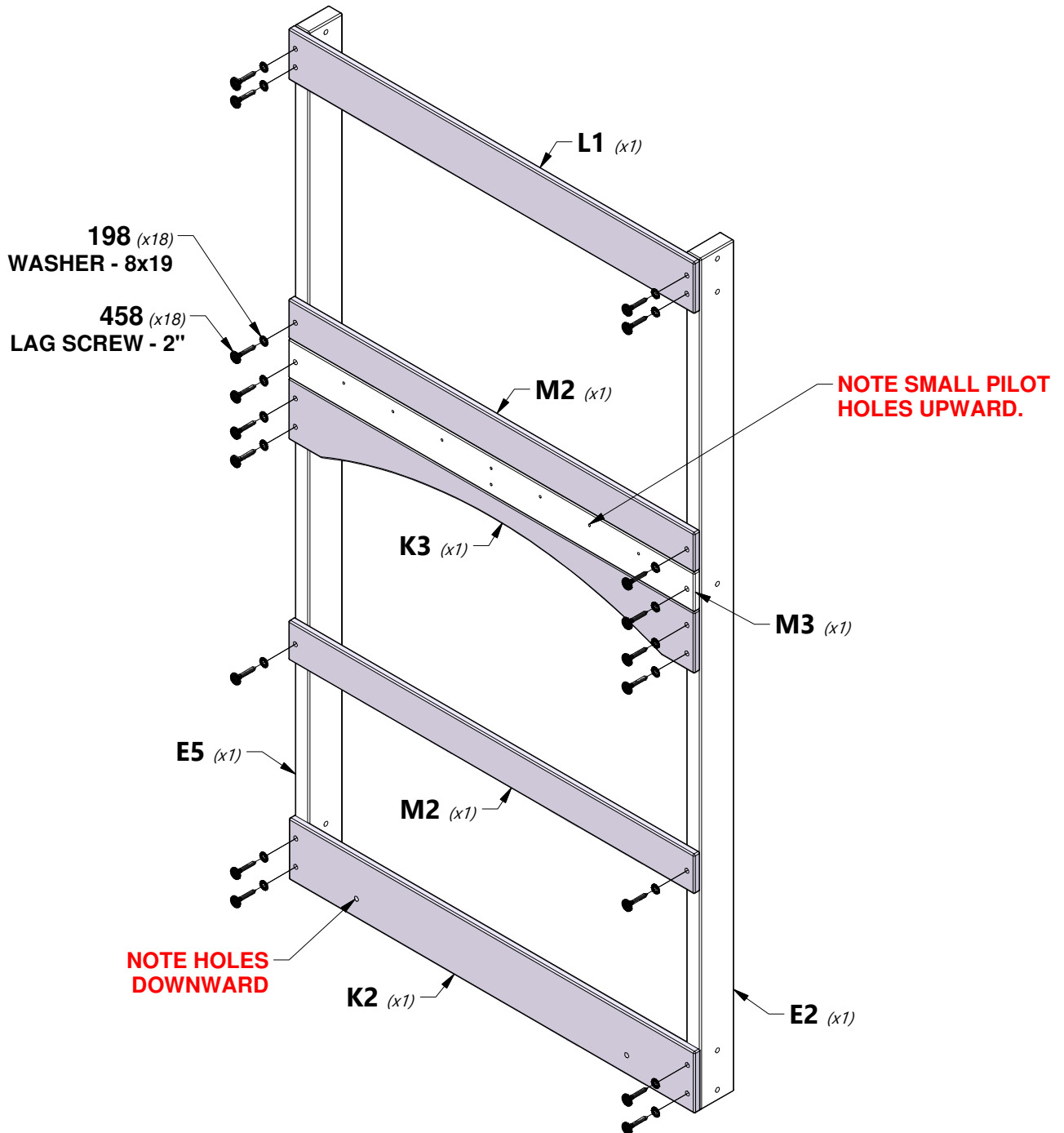

STEP 3 - FORT ASSEMBLY

QTY	PART NUMBER	DESCRIPTION
20	H100198	WASHER LOCK EXT 8x19 BLK
12	H100379	T-NUT 5/16 BLK
10	H100457	BOLT WH 5/16x2 BLK
10	H100458	LAG SCREW WH 5/16x2 BLK



L2 | WALL RAIL - W4L14564
(x1) | 5/8"x4 3/8"x64 3/4" (16x112x1644)



L3 | WALL RAIL - W4L14565
(x1) | 5/8"x4 3/8"x64 3/4" (16x112x1644)



K1 | GROUND BOARD - W4L14557
(x2) | 5/8"x5 1/4"x64 3/4" (16x134x1644)

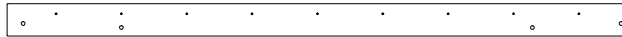

M1 | FLOOR SUPPORT - W4L14571
(x1) | 5/8"x3 3/8"x64 3/4" (16x86x1644)

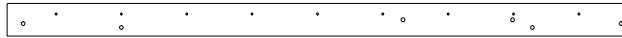

M30 | FLOOR SUPPORT - W4L14598
(x1) | 5/8"x3 3/8"x64 3/4" (16x86x1644)

TIP:
INSTALL T-NUTS IN WOOD FIRST

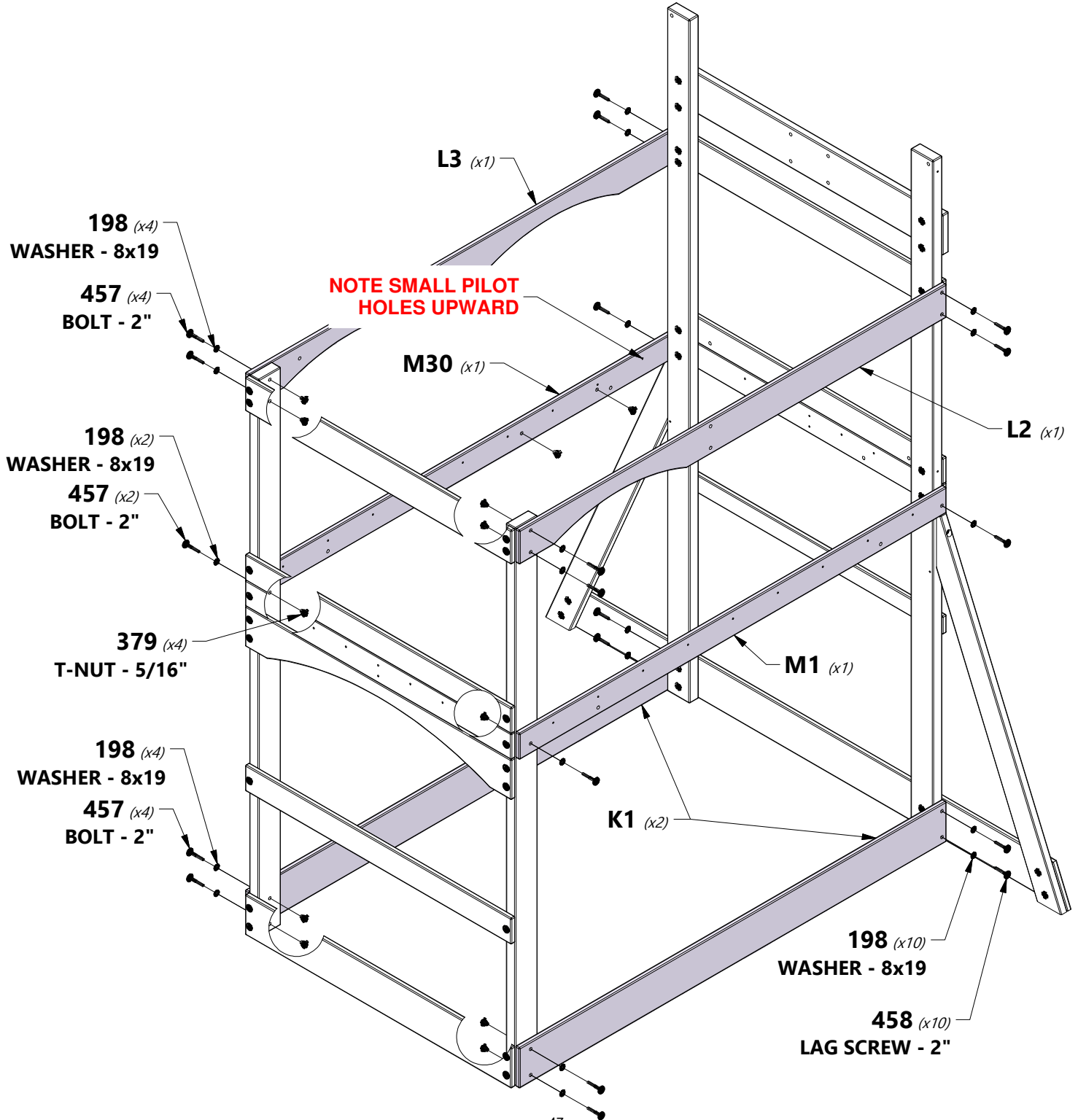

STEP 4 - FORT ASSEMBLY

F1 DECK BRACE - W4L14541
 (x6) 1"x2 3/8"x15 3/4" (24x60x400)

QTY	PART NUMBER	DESCRIPTION
6	H100198	WASHER LOCK EXT 8x19 BLK
6	H100379	T-NUT 5/16 BLK
6	H100405	WASHER LOCK EXT 6x15 BLK
6	H100407	BOLT WH 5/16x1 1/2 BLK
6	H100487	LAG SCREW WH 1/4x2 BLK

TIP:
 INSTALL T-NUTS IN WOOD FIRST

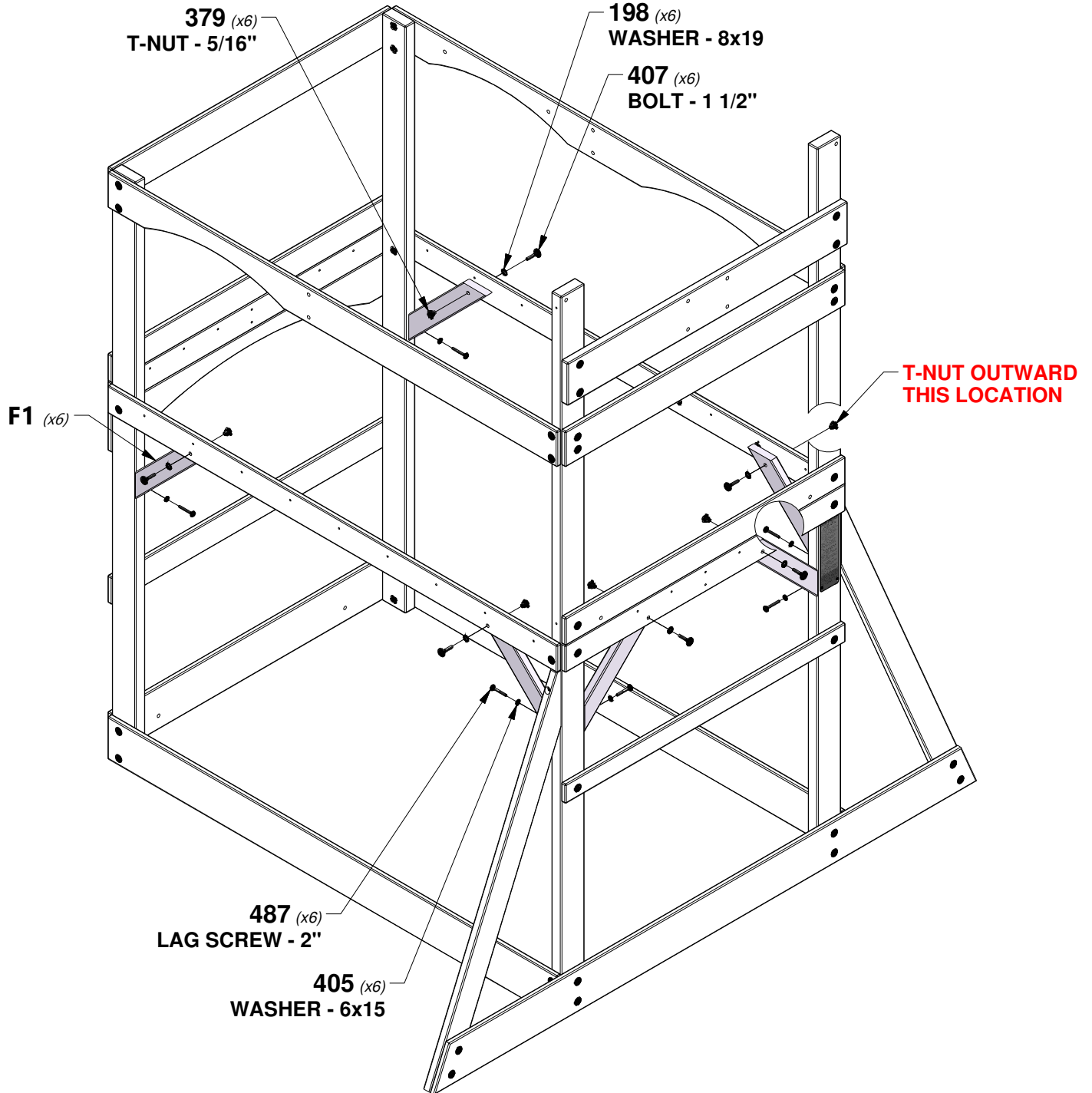

STEP 5 - FORT ASSEMBLY

QTY	PART NUMBER	DESCRIPTION
46	H100088	SCREW PFH 8x1-1/8"

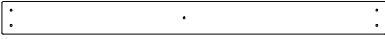

M9 | WALL BOARD - W4L14579
(x2) | 5/8"x3 3/8"x40" (16x86x1016)

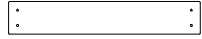

M10 | WALL BOARD - W4L14580
(x9) | 5/8"x3 3/8"x20" (16x86x508)

TIP:
INSTALL T-NUTS IN WOOD FIRST

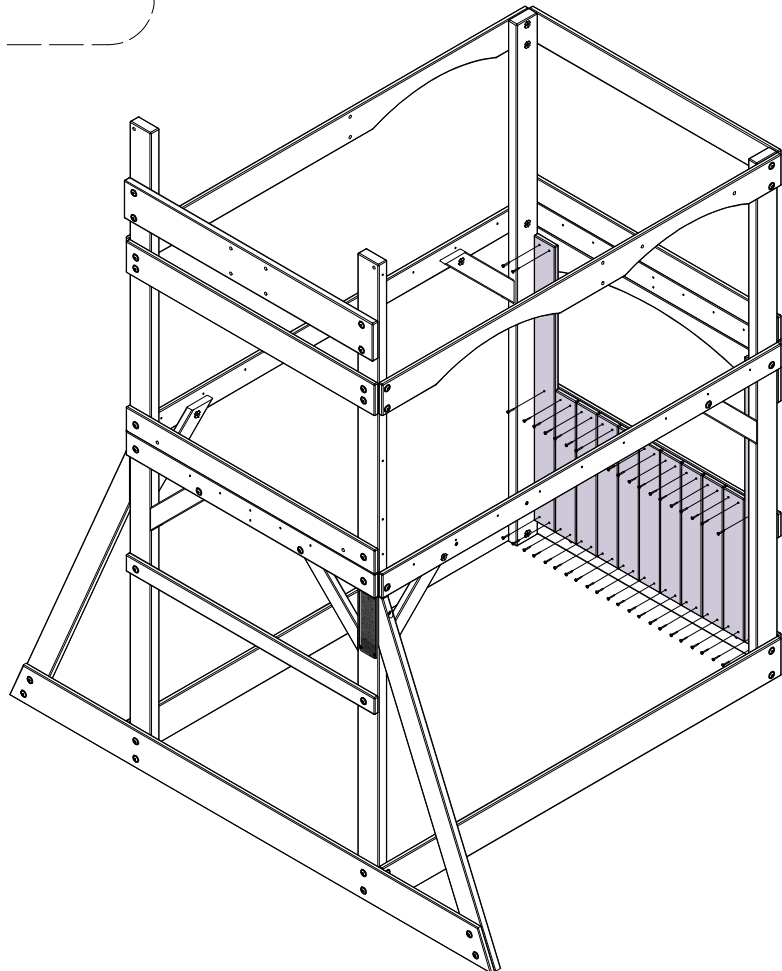
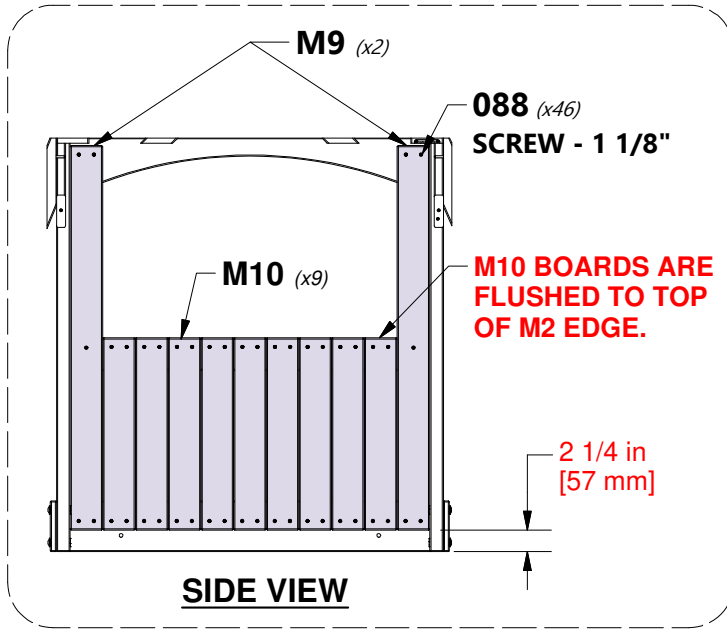

STEP 6 - FORT ASSEMBLY

QTY	PART NUMBER	DESCRIPTION
7	H100087	SCREW PFH 8x1-1/4"

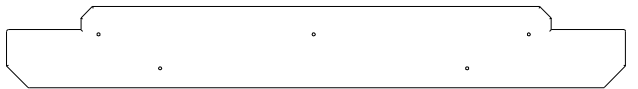

K5 | COUNTER TOP - W4L14561
(x1) | 5/8"x5 1/4"x40 3/8" (16x134x1024)

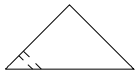

H1 | TABLE SUPPORT - W4L14543
(x2) | 1"x2"x4" (24x51x102)

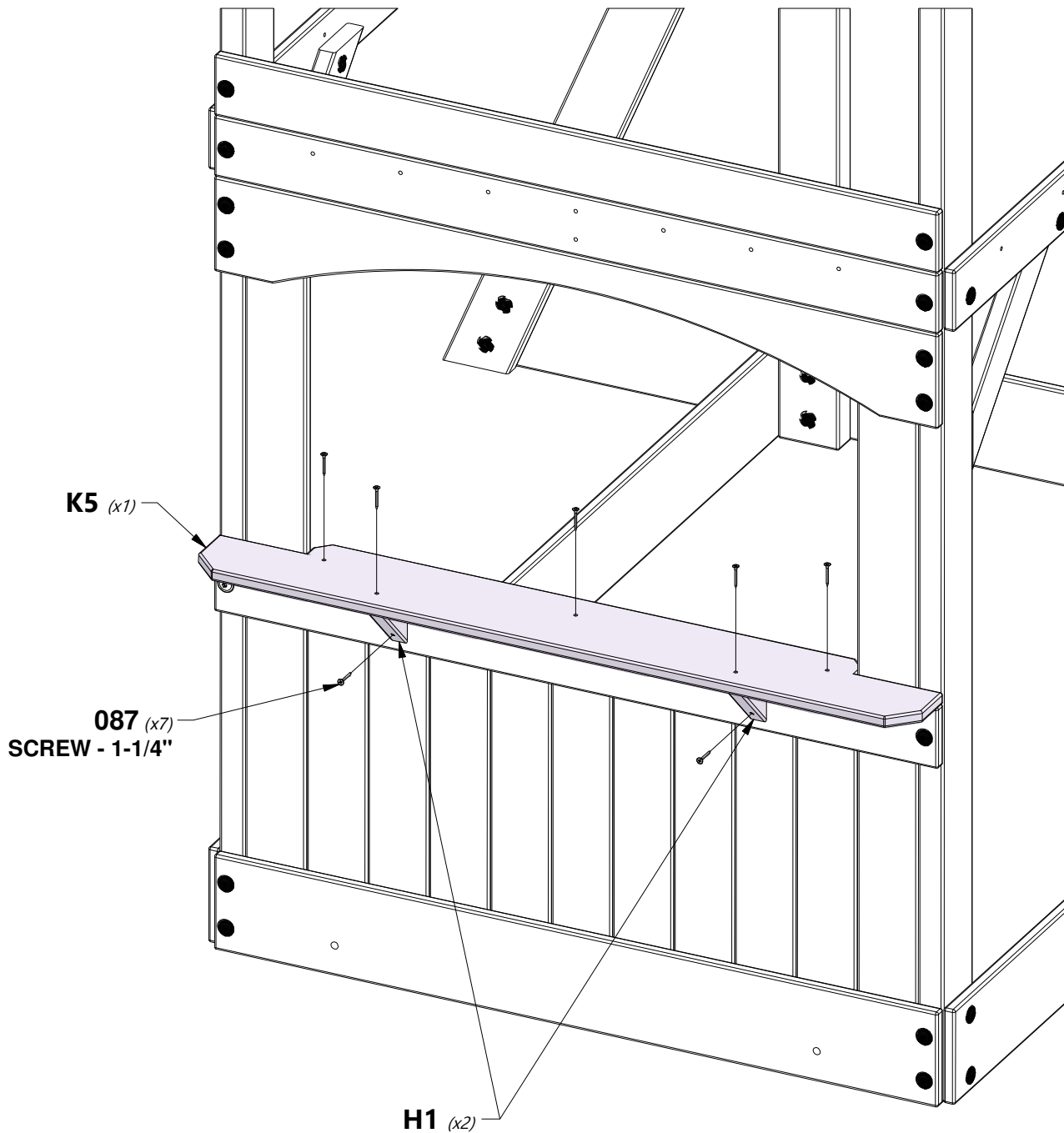

STEP 7 - FORT ASSEMBLY

QTY	PART NUMBER	DESCRIPTION
28	H100086	SCREW PFH 8x1-1/2"

S1 | FLOOR SUPPORT - W4L14612
(x2) | 1"x1"x59 7/8" (24x24x1522)

S2 | FLOOR SUPPORT - W4L14613
(x1) | 1"x1"x37 1/2" (24x24x952)

S3 | FLOOR SUPPORT - W4L14614
(x1) | 1"x1"x33 1/2" (24x24x852)

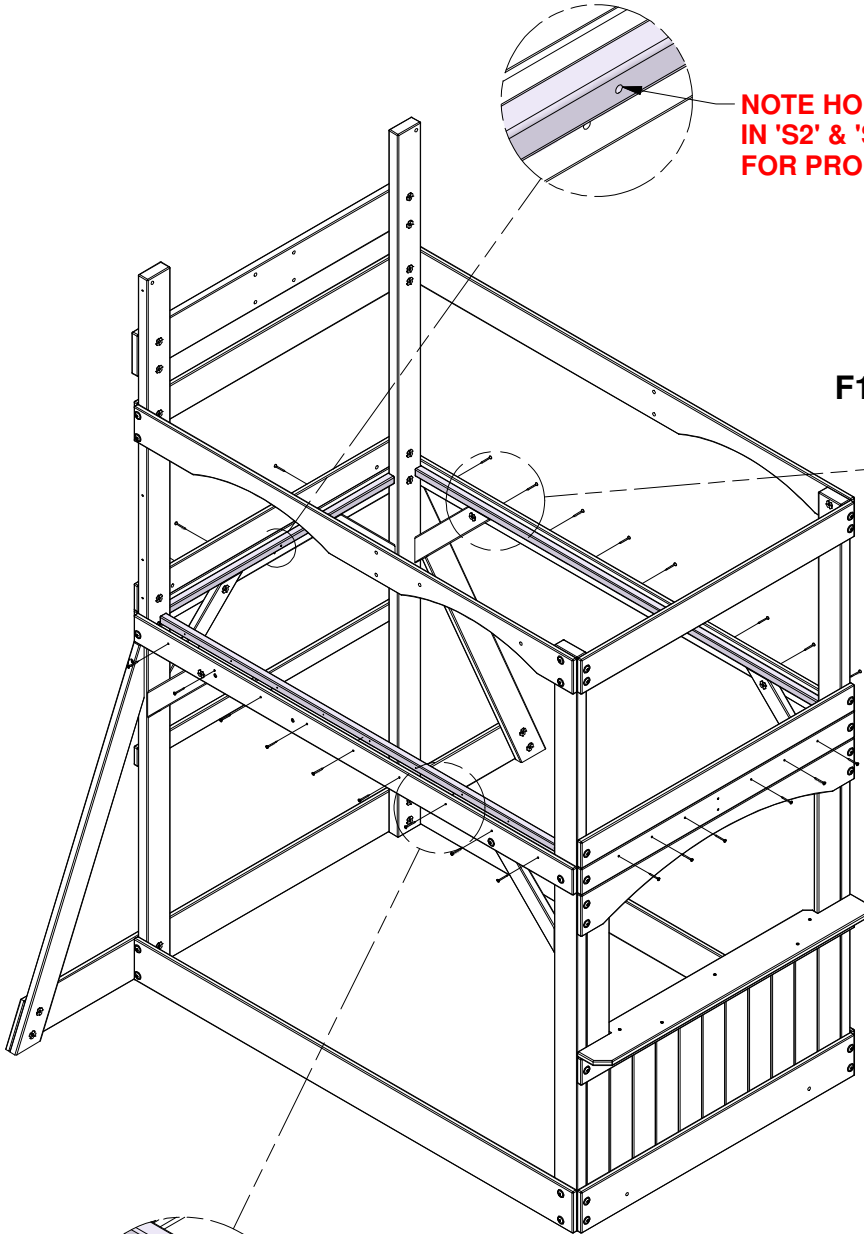

**NOTE HOLE LOCATION
IN 'S2' & 'S3' BOARDS
FOR PROPER ASSEMBLY.**

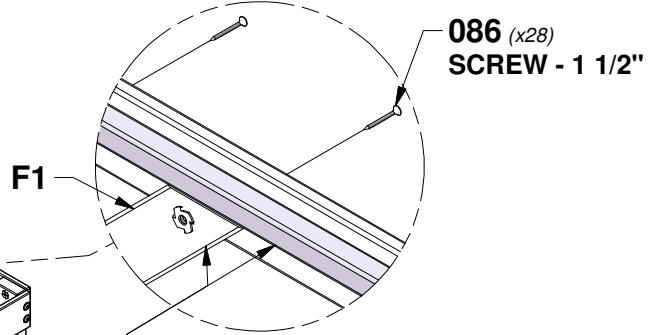

**NOTE: S1 AND S3 BOARDS SHOULD
SIT ON F1 BRACE BOARDS. TOP OF
S2 BOARD IS FLUSH WITH THE TOP
OF BOTH S1 BOARDS.**

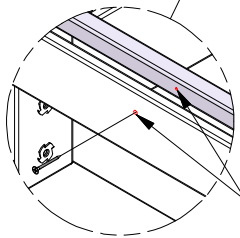

**ALIGN PILOT HOLES IN (S) BOARDS
WITH THRU HOLES IN THEIR MATING
BOARDS.**

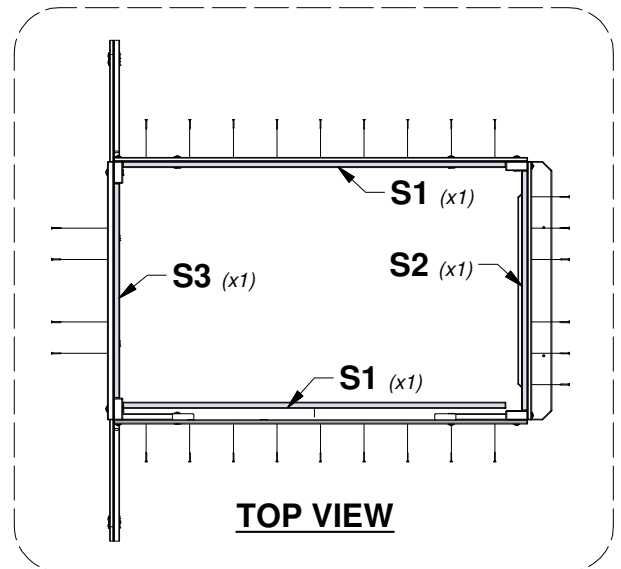

STEP 8 - FORT ASSEMBLY

QTY	PART NUMBER	DESCRIPTION
4	H100090	SCREW PFH 8x2 1/2

J1 | JOIST - W4L14556
(x1) | 1"x2 3/8"x64 3/4" (24x60x1644)

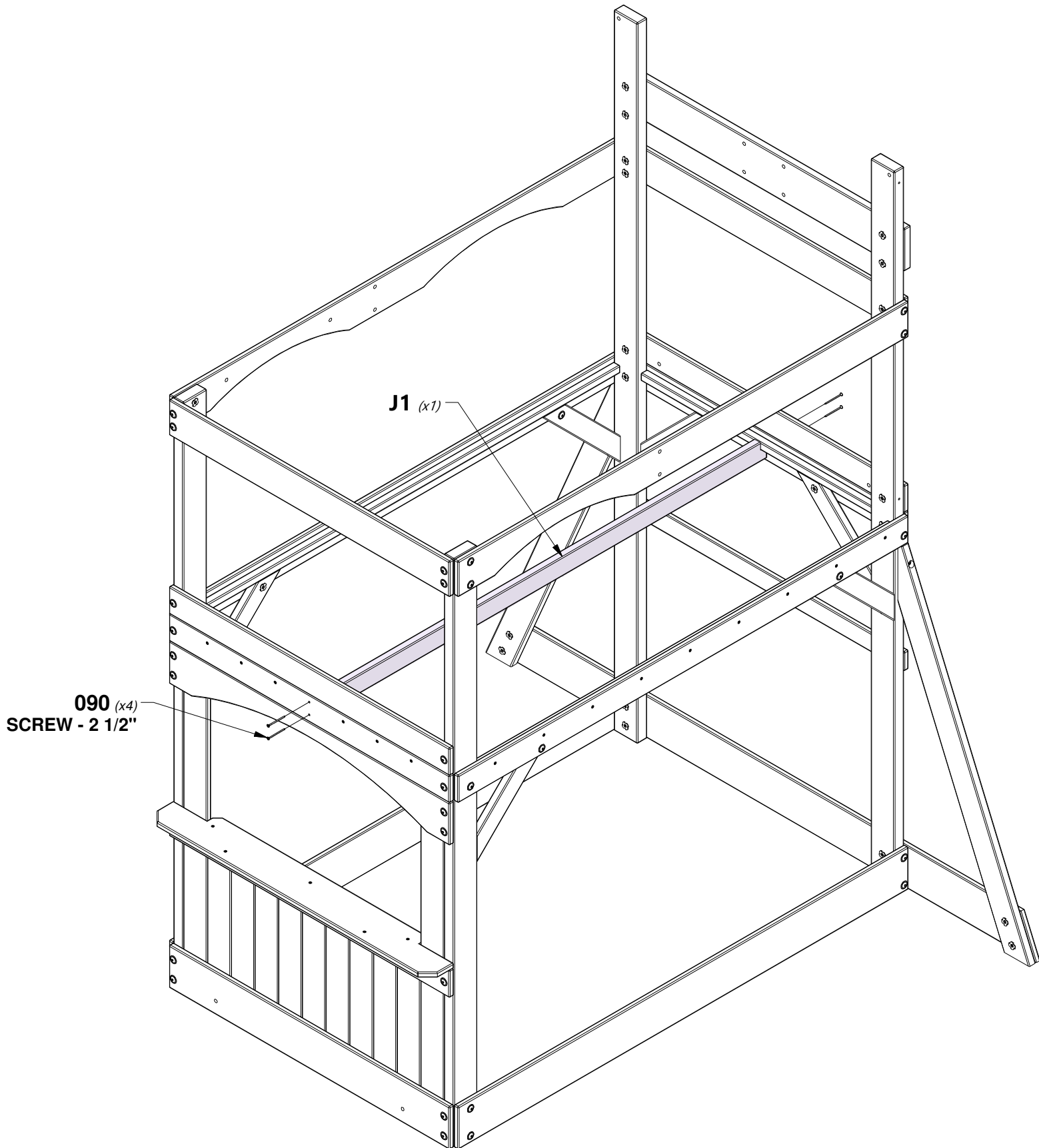

STEP 9 - FORT ASSEMBLY

QTY	PART NUMBER	DESCRIPTION
91	H100086	SCREW PFH 8x1-1/2"

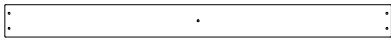

M4 | FLOOR BOARD - W4L14574
(x2) | 5/8"x3 3/8"x40 3/8" (16x86x1024)

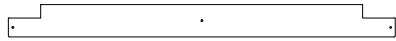

M5 | FLOOR BOARD - W4L14575
(x1) | 5/8"x3 3/8"x40 3/8" (16x86x1024)

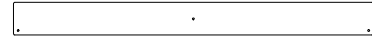

M6 | FLOOR BOARD - W4L14576
(x1) | 5/8"x3 3/8"x37 1/2" (16x86x952)



FP1 | FLOOR PANEL - W2A03131
(x3) | 1 1/4"x17"x40 5/16" (32x432x1024)

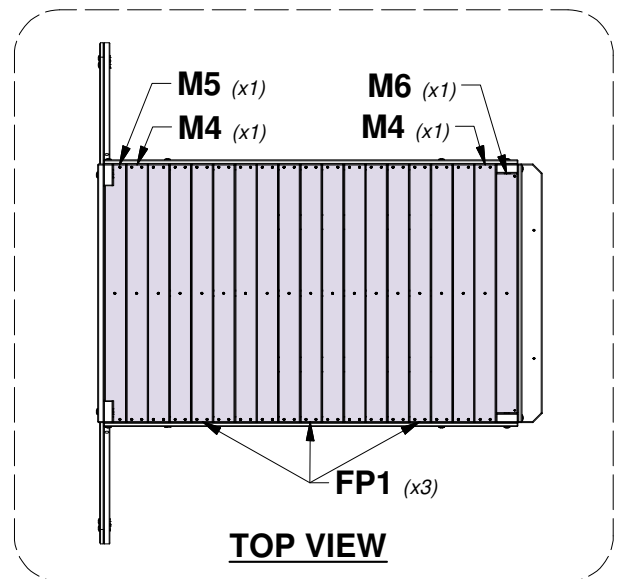
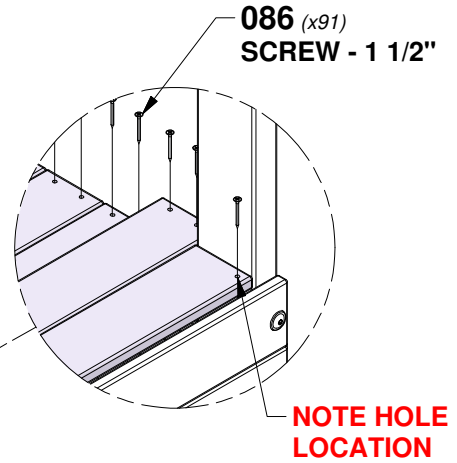
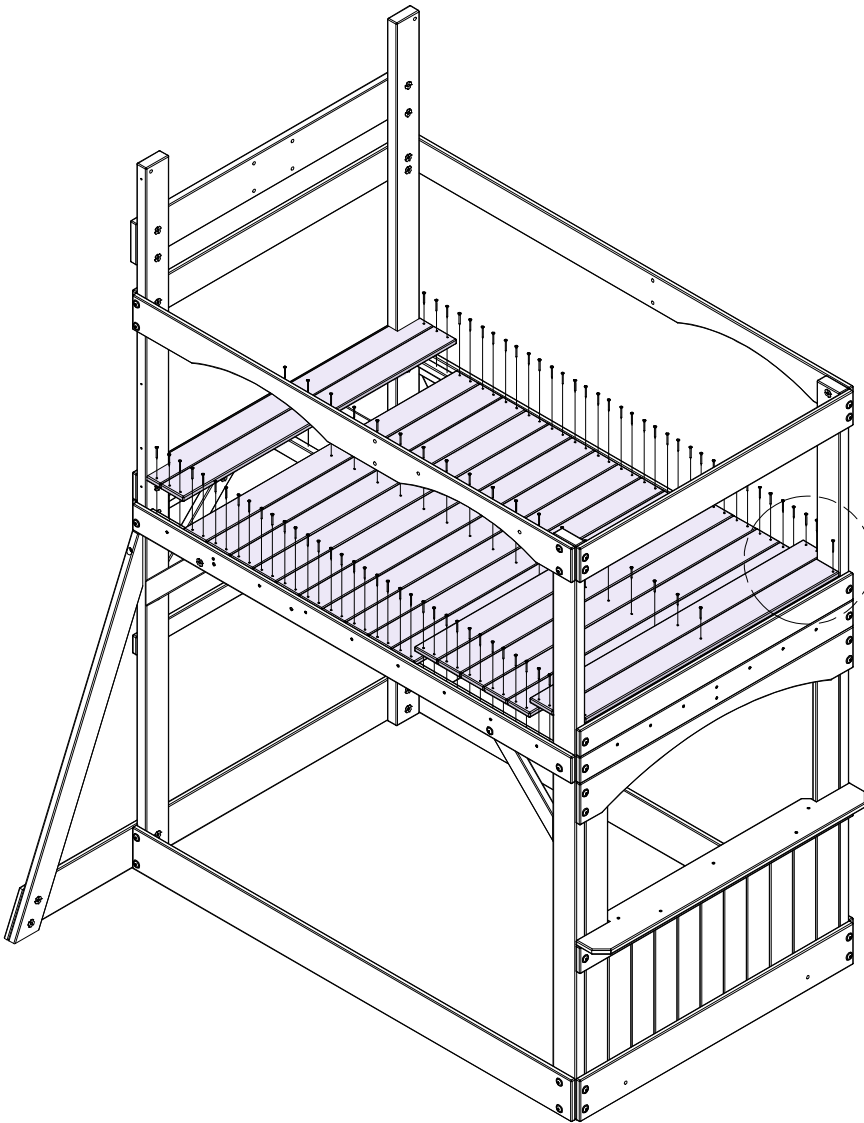

STEP 10 - FORT ASSEMBLY

QTY	PART NUMBER	DESCRIPTION
4	H100198	WASHER LOCK EXT 8x19 BLK
4	H100379	T-NUT 5/16 BLK
4	H100457	BOLT WH 5/16x2 BLK

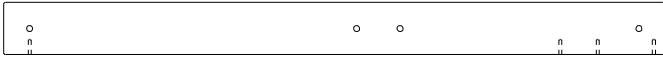

E4 | CLUB HOUSE LEG - W4L14534
(x1) | 1 3/8"x3 3/8"x43 1/8" (36x86x1094)

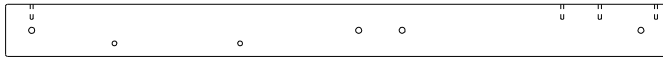

E8 | CLUB HOUSE LEG - W4L14537
(x1) | 1 3/8"x3 3/8"x43 1/8" (36x86x1094)

TIP:
INSTALL T-NUTS IN WOOD FIRST

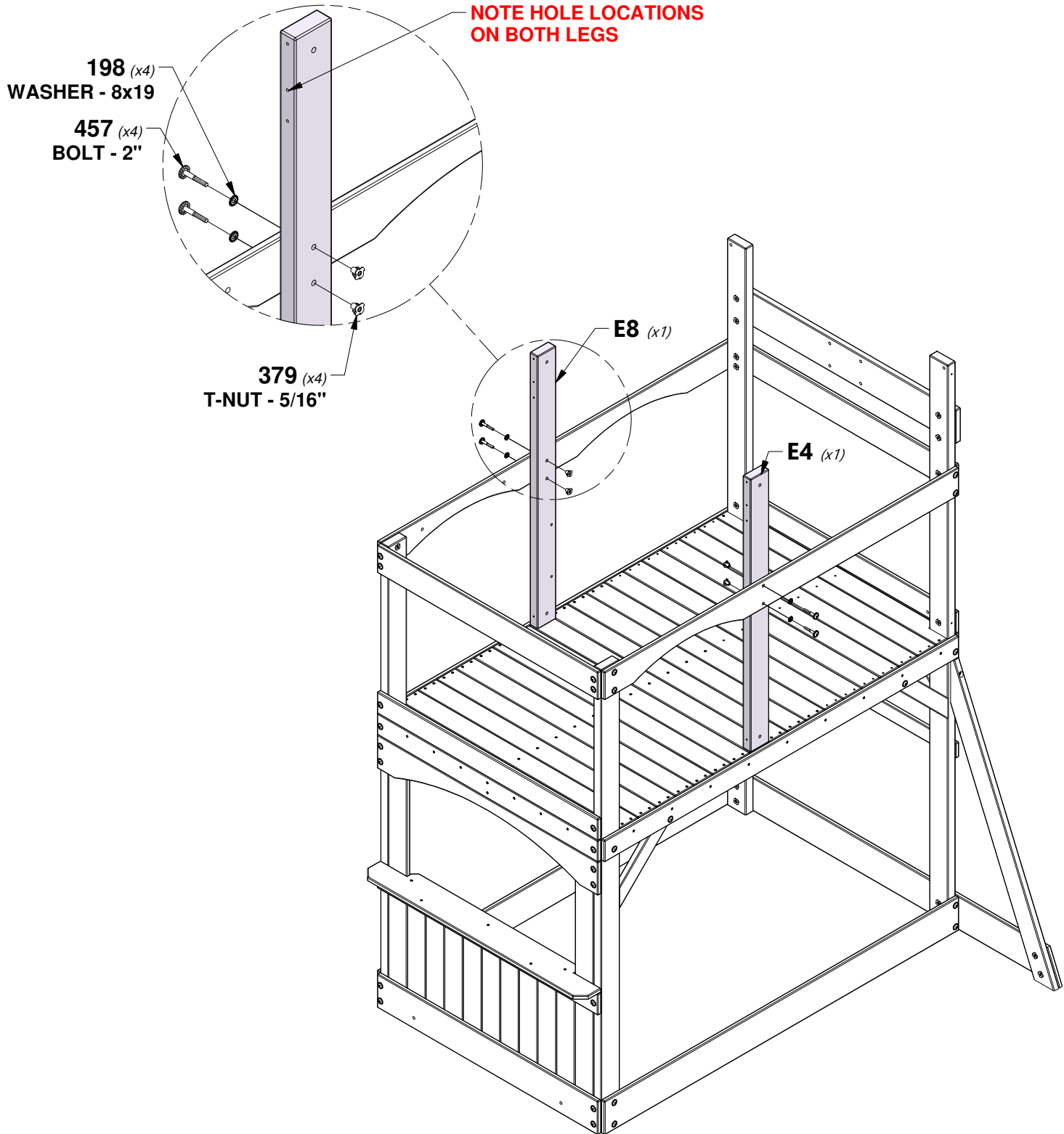

STEP 11 - FORT ASSEMBLY

M11 FLOOR SUPPORT - W4L14581
(x1) 5/8"x3 3/8"x37 1/2" (16x86x951)

M17 WALL RAIL - W4L14587
(x1) 5/8"x3 3/8"x6 3/4" (16x86x173)

M15 WALL RAIL - W4L14585
(x2) 5/8"x3 3/8"x8 1/2" (16x86x216)

M18 WALL RAIL - W4L14588
(x1) 5/8"x3 3/8"x4 3/4" (16x86x122)



A4M01046 L BRACKET
(x2) 2.5x38x55x55

QTY	PART NUMBER	DESCRIPTION
2	H100192	NUT BARREL WH 5/16x7/8 BLK
4	H100198	WASHER LOCK EXT 8x19 BLK
2	H100199	WASHER LOCK EXT 12x19 BLK
2	H100378	BOLT WH 5/16x1 3/4 BLK
2	H100379	T-NUT 5/16 BLK
2	H100396	BOLT WH 5/16x1/2 BLK
4	H100458	LAG SCREW WH 5/16x2 BLK

TIP:
INSTALL T-NUTS IN WOOD FIRST

USING BRACKETS AS A GUIDE
DRILL 3/8" [10mm] HOLE THRU
FLOOR FOR HARDWARE.

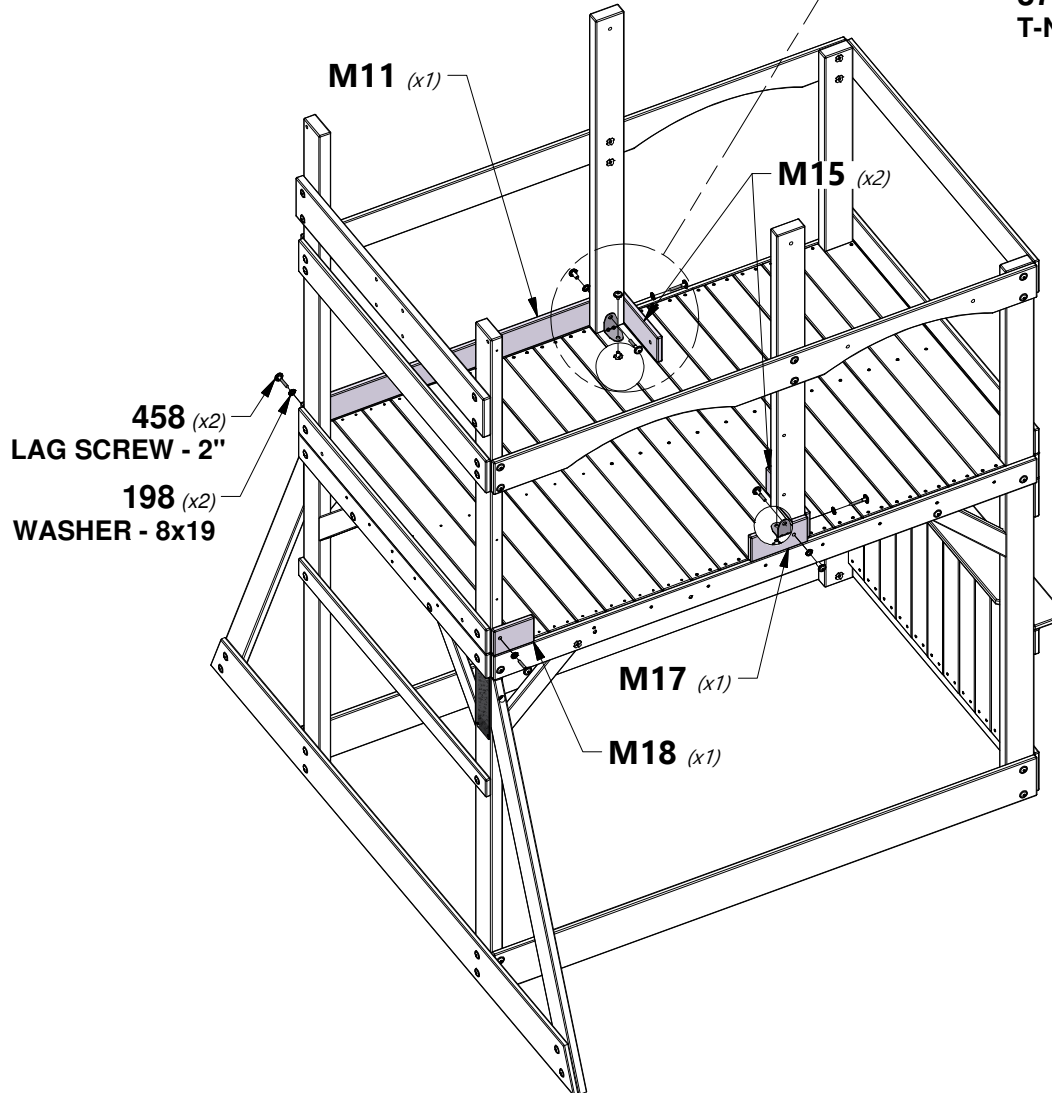
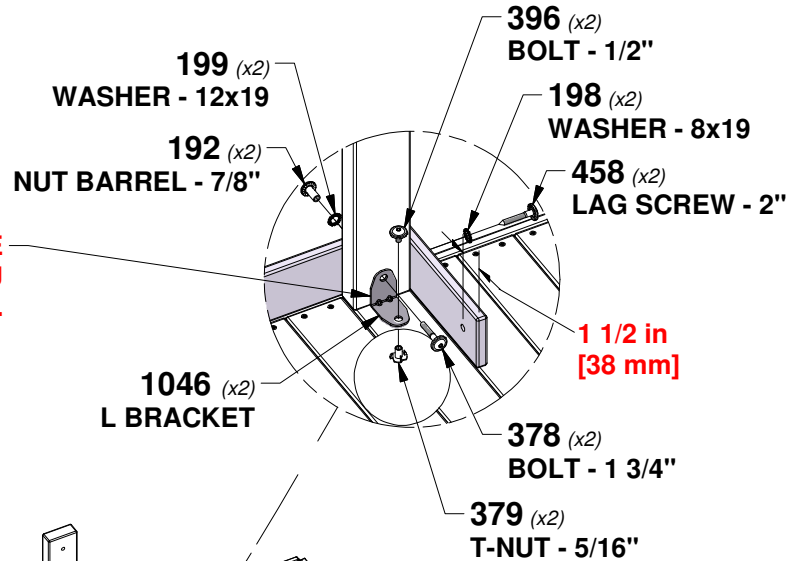

STEP 12 - FORT ASSEMBLY

QTY	PART NUMBER	DESCRIPTION
12	H100088	SCREW PFH 8x1-1/8"



N2 | PICKET - W4L14603
 (x6) | 5/8"x2 3/8"x22" (16x60x558)

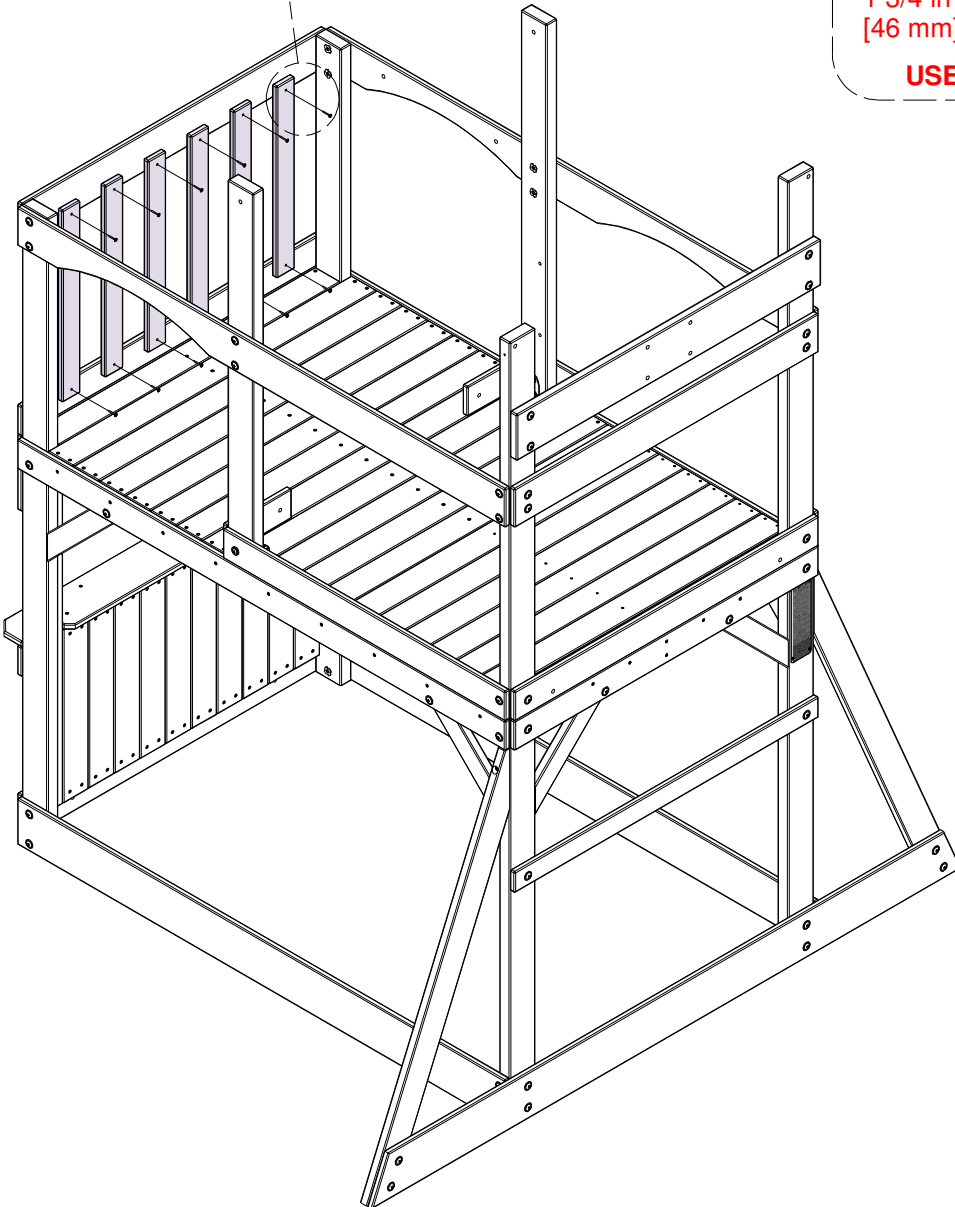
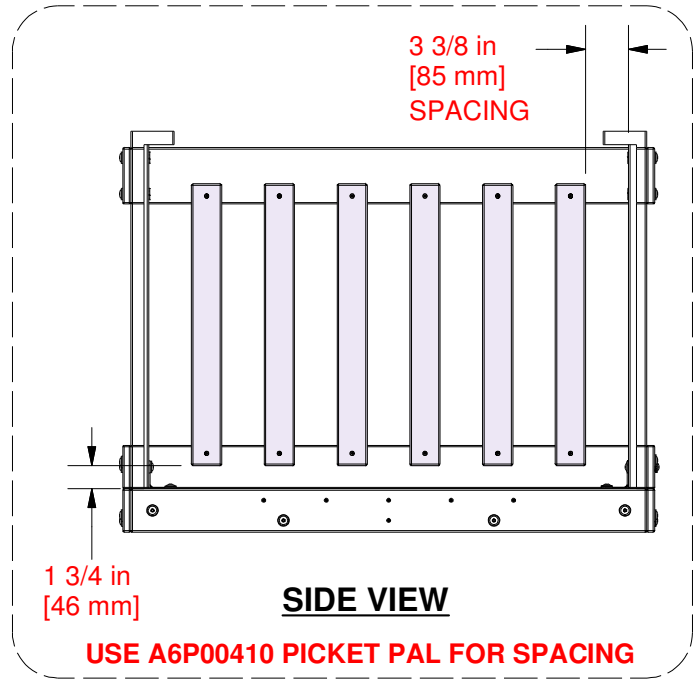
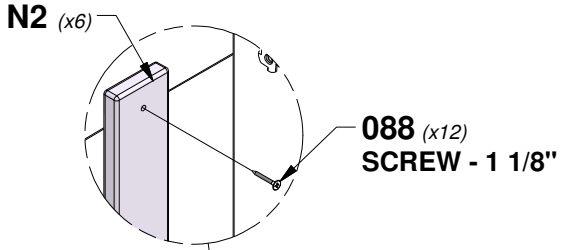

STEP 13 - FORT ASSEMBLY

QTY	PART NUMBER	DESCRIPTION
8	H100198	WASHER LOCK EXT 8x19 BLK
2	H100379	T-NUT 5/16 BLK
2	H100457	BOLT WH 5/16x2 BLK
6	H100458	LAG SCREW WH 5/16x2 BLK



L5 | CLUB HOUSE WALL RAIL - W4L14567
(x1) 5/8"x4 3/8"x40 3/8" (16x112x1024)

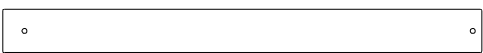

M21 | WALL RAIL - W4L14591
(x2) 5/8"x3 3/8"x37 1/2" (16x86x951)

TIP:
INSTALL T-NUTS IN WOOD FIRST

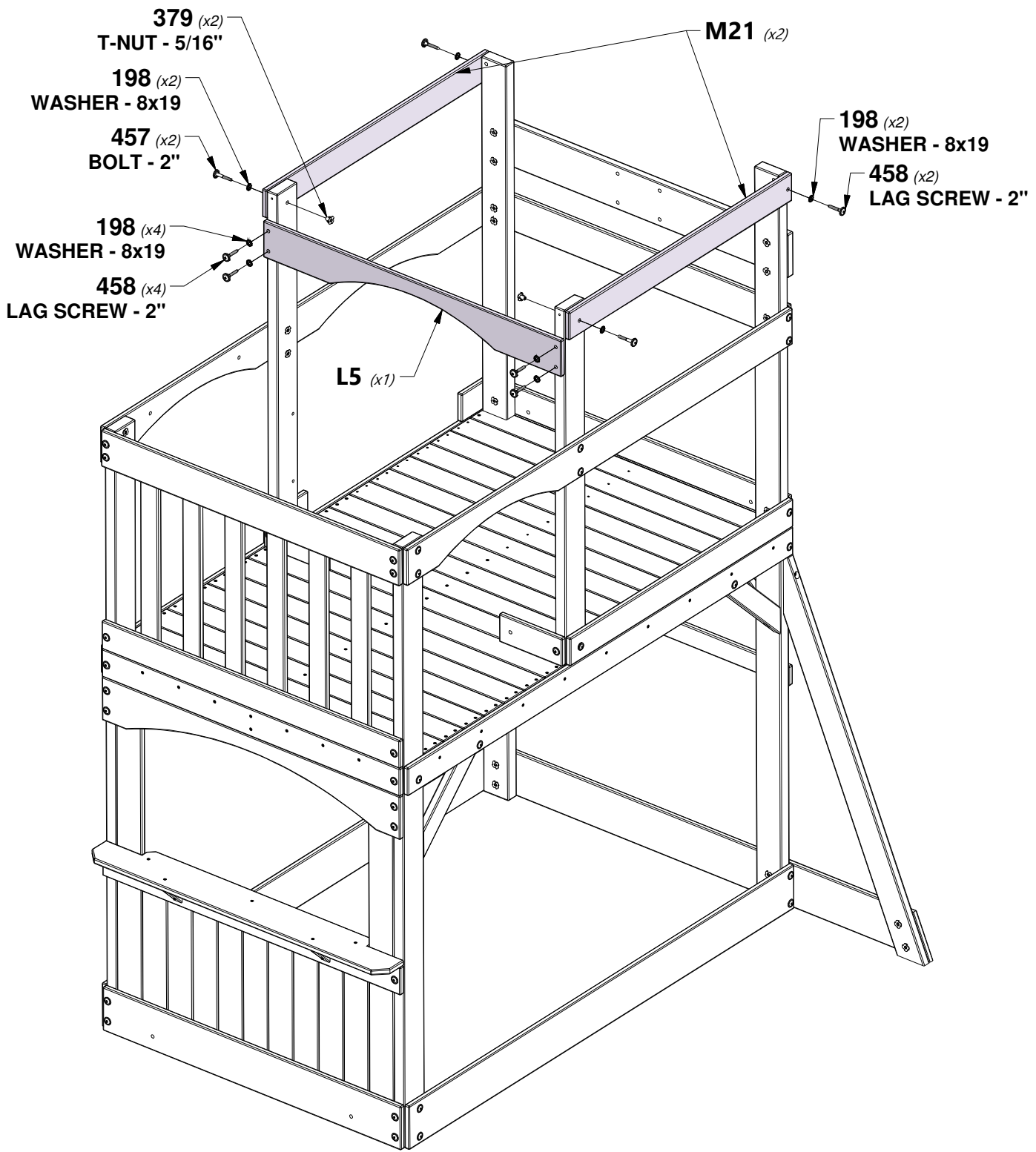

STEP 14 - FORT ASSEMBLY

QTY	PART NUMBER	DESCRIPTION
16	H100088	SCREW PFH 8x1-1/8"
2	H100192	NUT BARREL WH 5/16x7/8 BLK
2	H100199	WASHER LOCK EXT 12x19 BLK
2	H100379	T-NUT 5/16 BLK
2	H100396	BOLT WH 5/16x1/2 BLK
2	H100468	BOLT WH 5/16x1 BLK

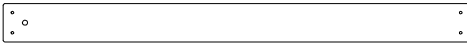

M14 | WALL BOARD - W4L14584
(x1) 5/8"x3"x36 1/2" (16x76x926)

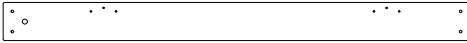

M33 | WALL BOARD - W4L14600
(x1) 5/8"x3"x36 1/2" (16x76x926)



Y1 | WALL BOARD - W4L14616
(x2) 5/8"x4"x34 5/8" (16x102x880)



A4M01046 | L BRACKET
(x2) 2.5x38x55x55

TIP:
INSTALL ALL 088 WOOD SCREWS FIRST.
THEN INSTALL BRACKETS AND REMAINING HARDWARE.

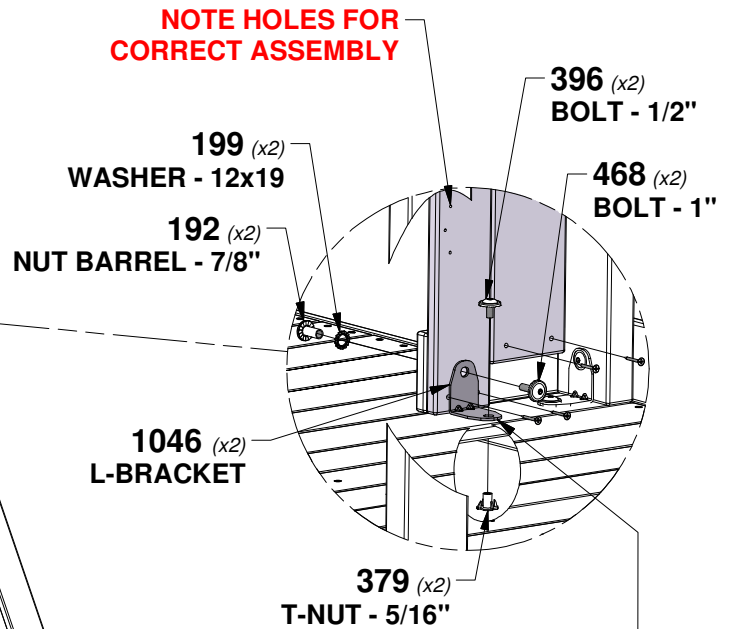
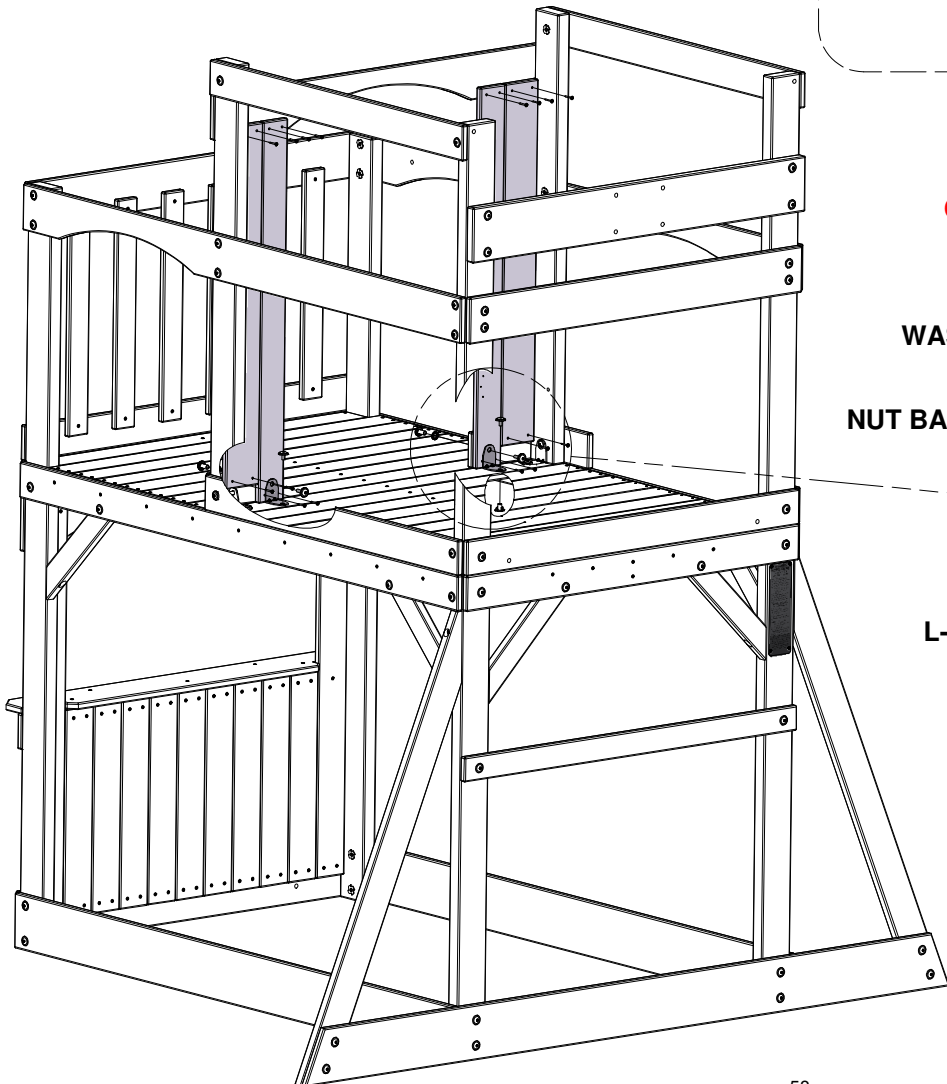
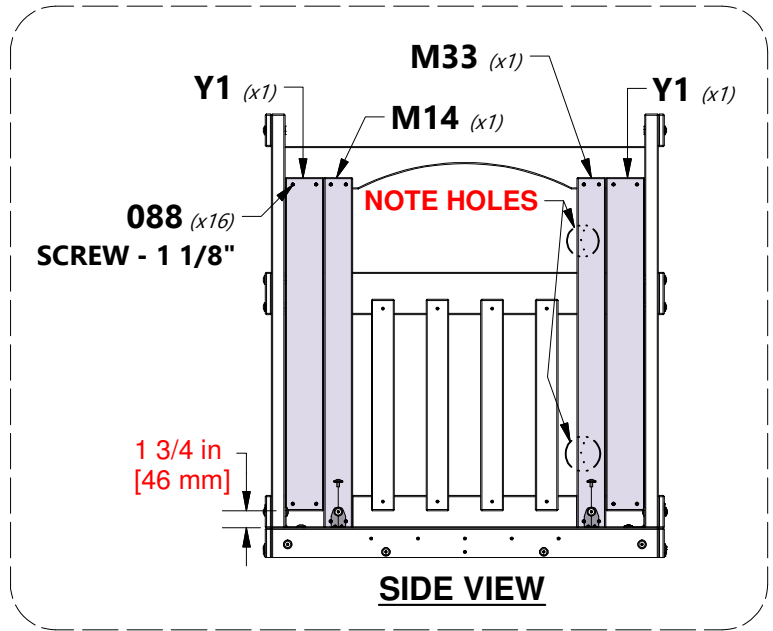

**USING BRACKETS AS A GUIDE
DRILL 3/8" [10mm] HOLE THRU
FLOOR FOR HARDWARE.**

STEP 15 - FORT ASSEMBLY

QTY	PART NUMBER	DESCRIPTION
36	H100088	SCREW PFH 8x1-1/8"



M19 | WALL BOARD - W4L14589
(x2) | 5/8"x3 3/8"x40 5/8" (16x86x1032)



M20 | WALL BOARD - W4L14590
(x2) | 5/8"x3 3/8"x16 1/4" (16x86x412)



M26 | WALL BOARD - W4L14596
(x8) | 5/8"x3 3/8"x3 1/2" (16x86x88)



K6 | WALL BOARD - W4L14562
(x1) | 5/8"x5 1/4"x16 1/4" (16x134x412)

NOTE EQUALLY SPACE WALL BOARDS

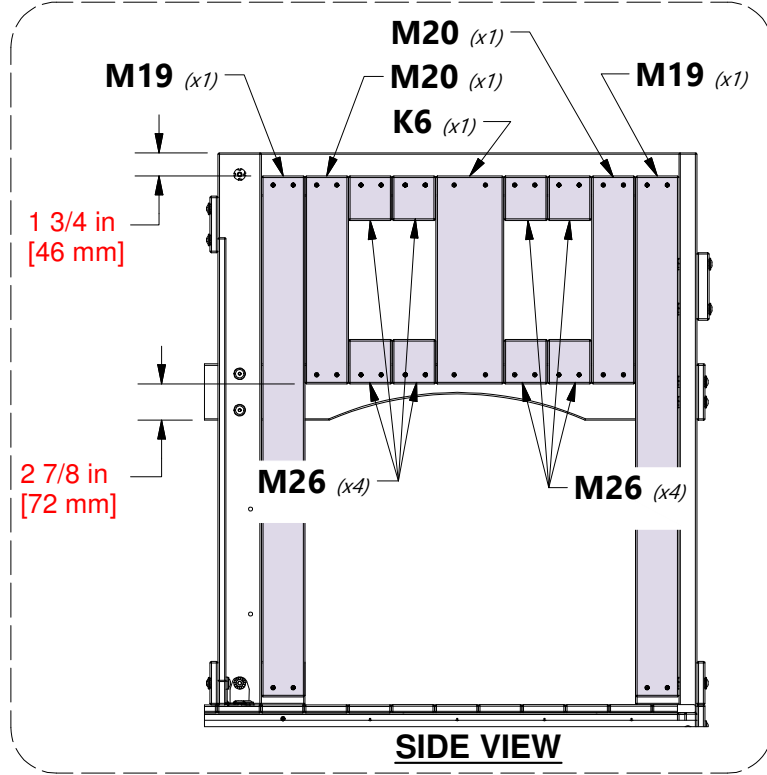

088 (x36)
SCREW - 1 1/8"

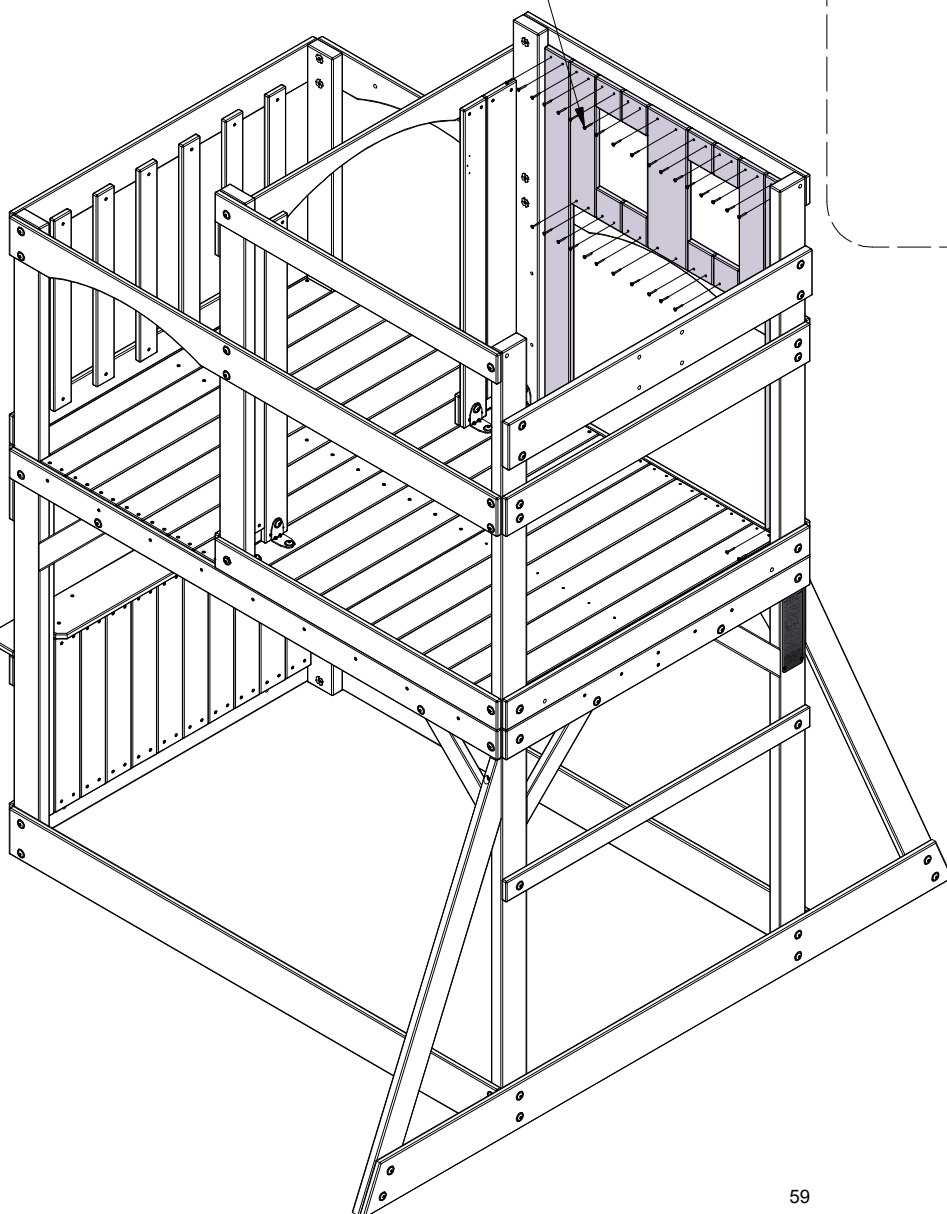

STEP 16 - FORT ASSEMBLY

QTY	PART NUMBER	DESCRIPTION
30	H100088	SCREW PFH 8x1-1/8"

17 3/4 in
[450 mm]

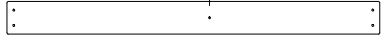

M12 | WALL BOARD - W4L14582
(x9) | 5/8"x3 3/8"x38 7/8" (16x86x986)

17 3/4 in
[450 mm]



M22 | WALL BOARD - W4L14592
(x1) | 5/8"x2 7/8"x38 7/8" (16x73x986)

NOTE EQUALLY SPACE WALL BOARDS

088 (x30)
SCREW - 1 1/8"

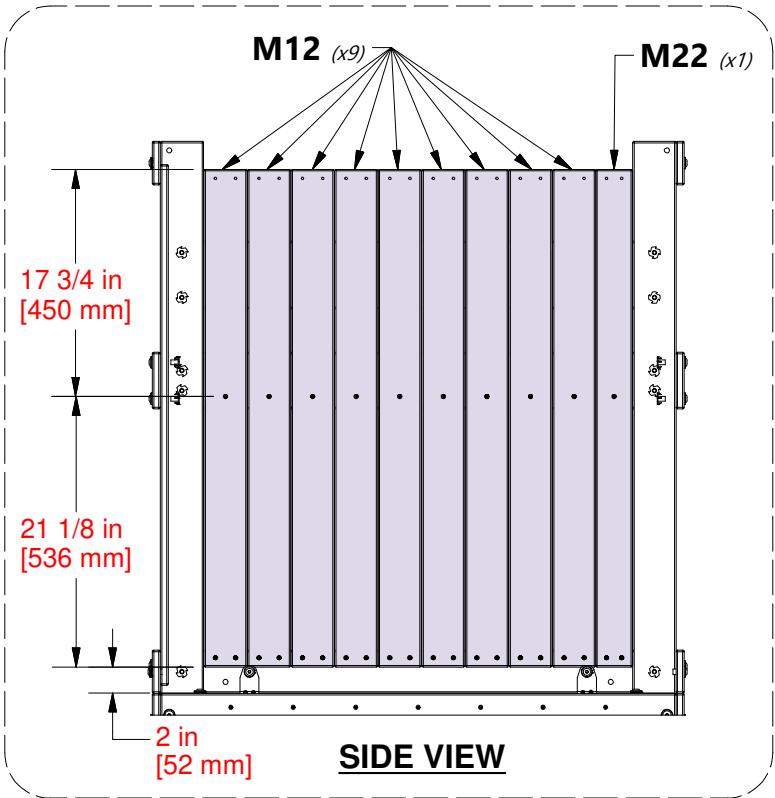
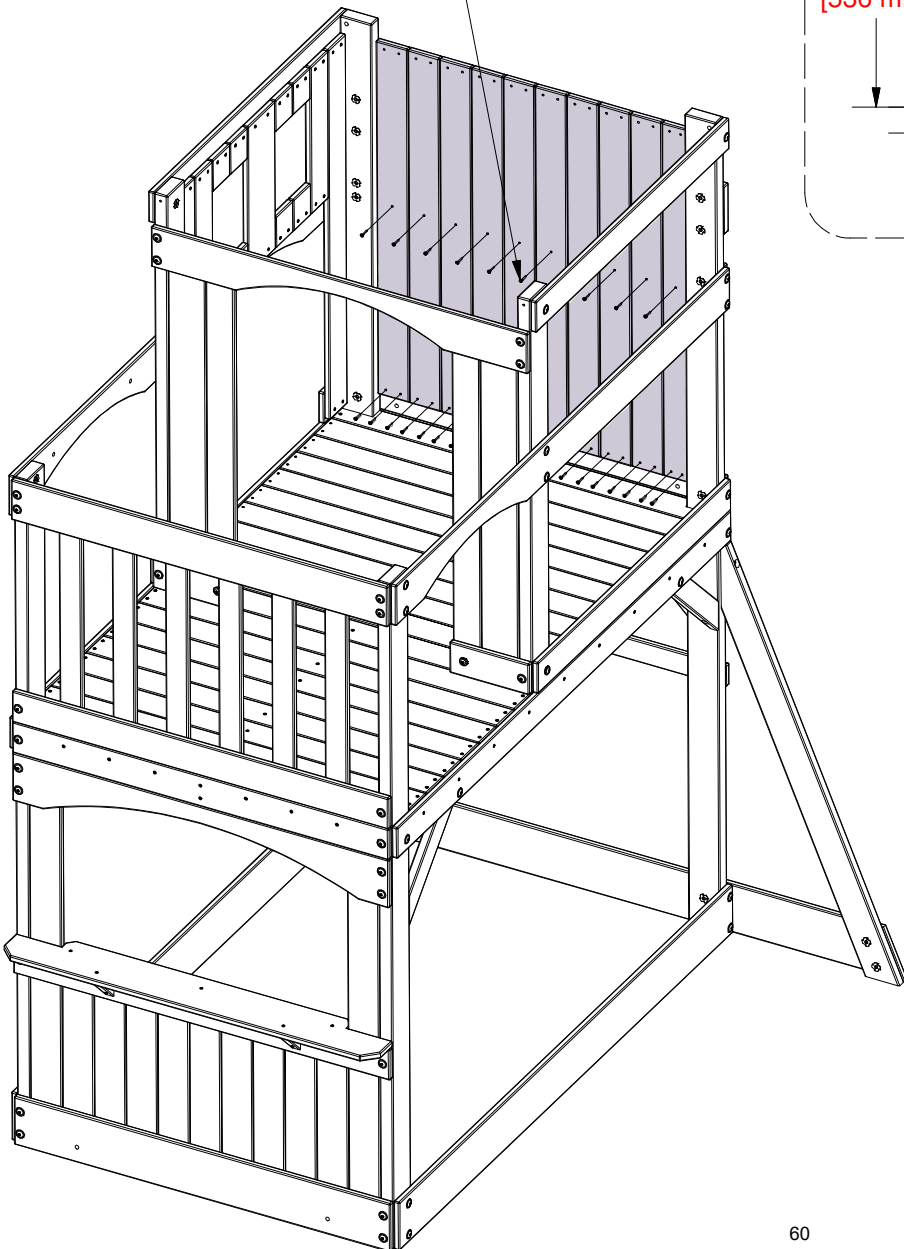

STEP 17 - FORT ASSEMBLY

QTY	PART NUMBER	DESCRIPTION
38	H100088	SCREW PFH 8x1-1/8"

N3 | WALL BOARD - W4L14604
 (x1) | 5/8"x2"x22" (16x50x558)

M13 | WALL BOARD - W4L14583
 (x9) | 5/8"x3 3/8"x22" (16x86x558)

NOTE EQUALLY SPACE WALL BOARDS

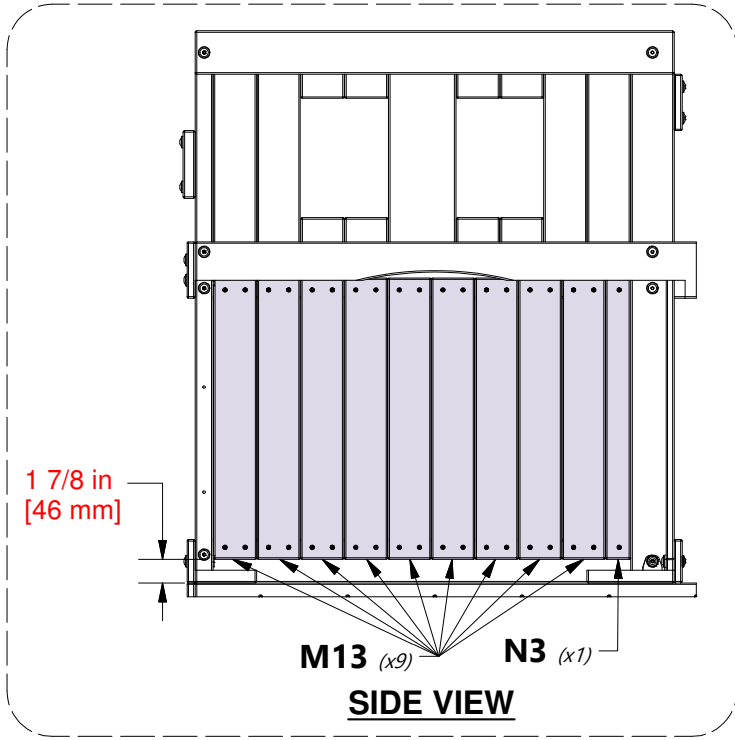

088 (x38)
SCREW - 1 1/8"



STEP 18 - FORT ASSEMBLY

QTY	PART NUMBER	DESCRIPTION
8	H100070	SCREW PWH 8x3/4

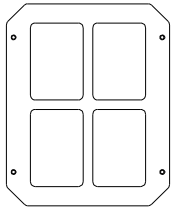

A100014
(x2) | **PLASTIC WINDOW WHITE**

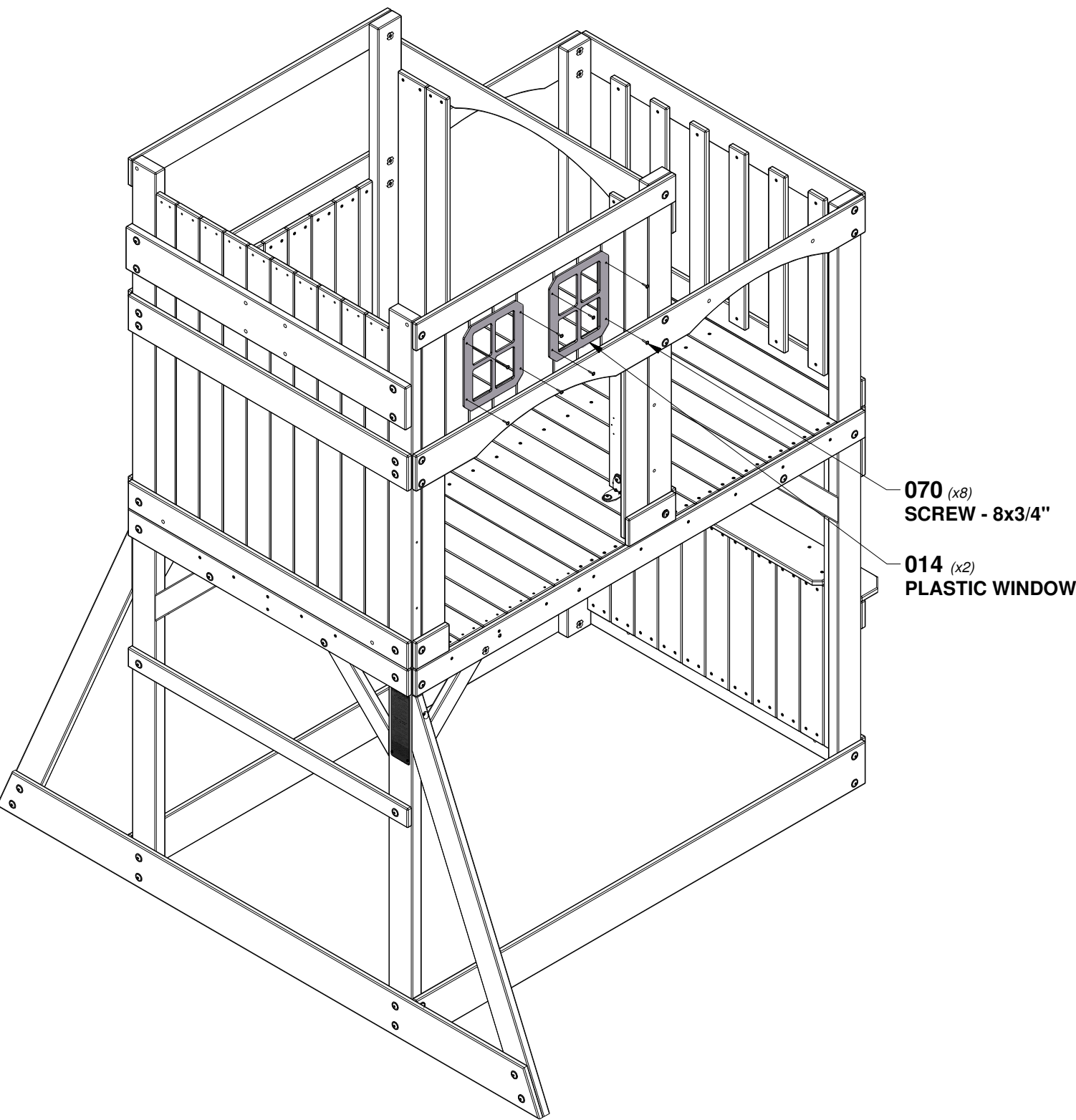

STEP 19 - FORT ASSEMBLY

QTY	PART NUMBER	DESCRIPTION
4	H100088	SCREW PFH 8x1-1/8"



Q2 | WALL BOARD - W4L14610
 (x2) | 5/8"x1 3/8"x15 1/2" (16x34x395)

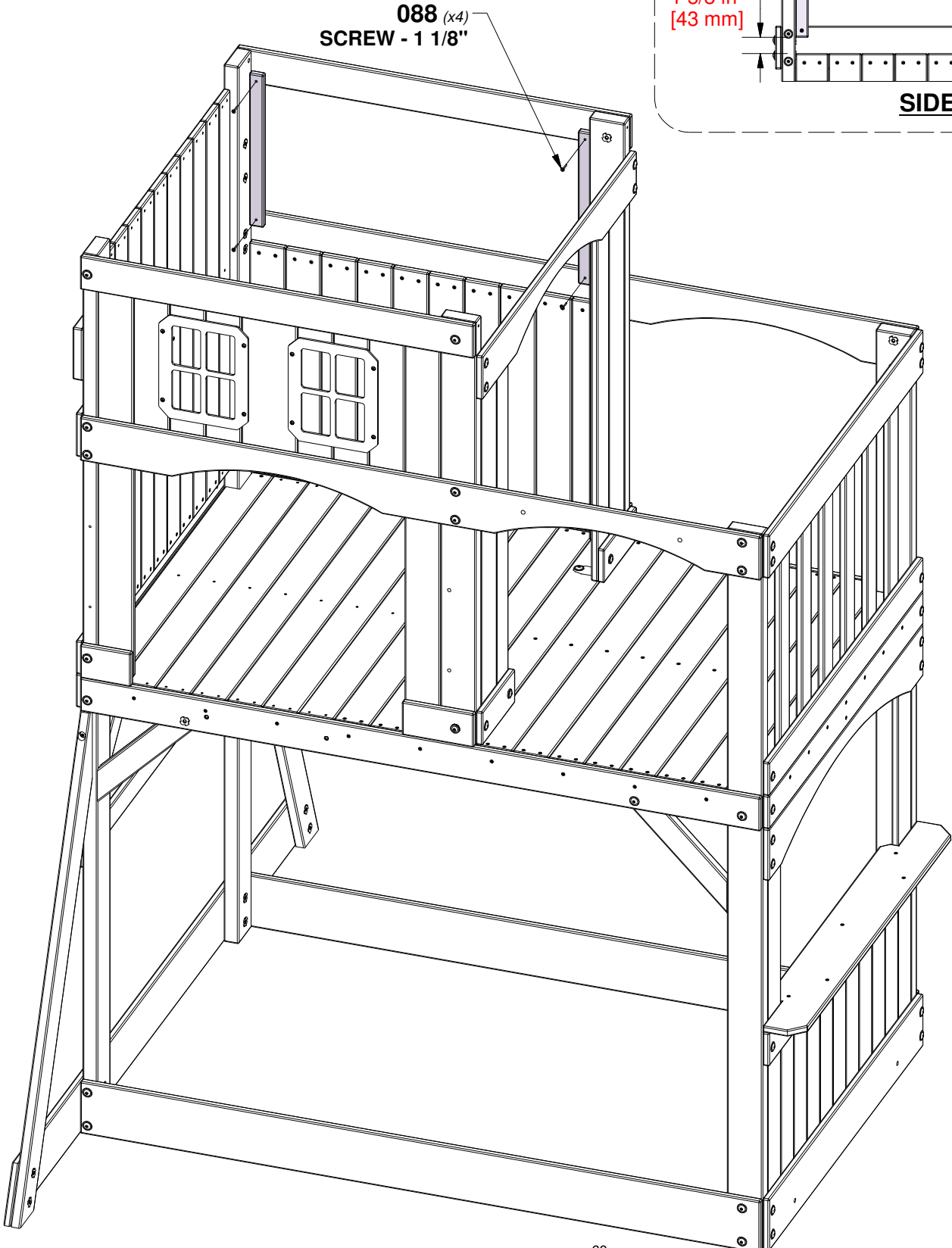
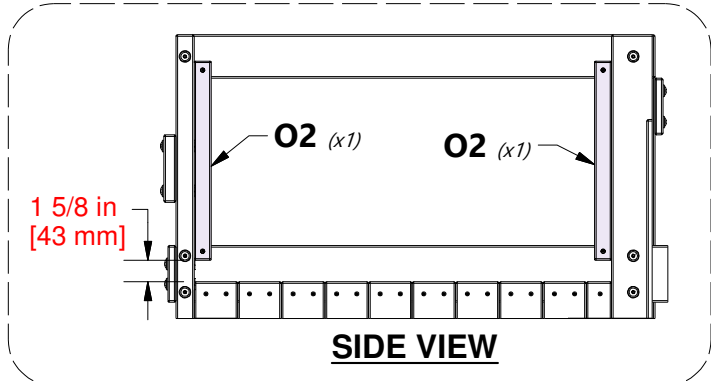

STEP 20 - FORT ASSEMBLY

QTY	PART NUMBER	DESCRIPTION
6	H100111	SCREW PFH 8x2

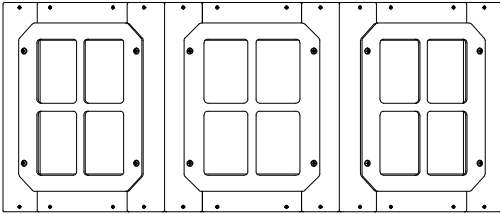

(x1)

MONTPELIER BAY WINDOW

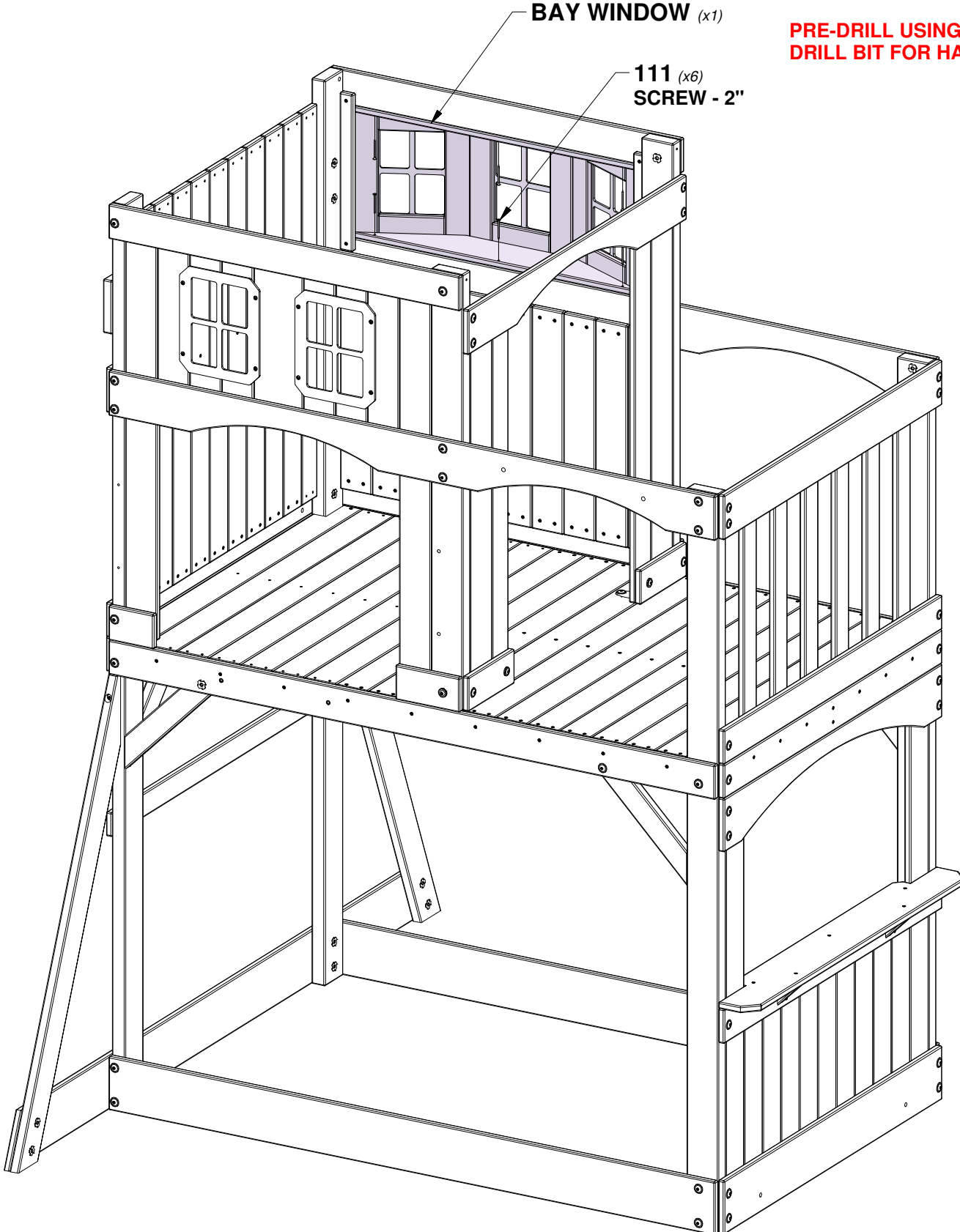

PRE-DRILL USING AN 1/8" [3mm] DRILL BIT FOR HARDWARE.

STEP 21 - FORT ASSEMBLY

QTY	PART NUMBER	DESCRIPTION
4	H100088	SCREW PFH 8x1-1/8"
6	H100624	SCREW PFH 6x5/8 BLK

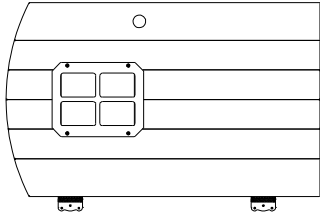

(x1) DOOR ASSEMBLY

N9 DOOR STOP - W4L14608
(x1) 5/8"x2 3/8"x8 3/4" (16x60x222)

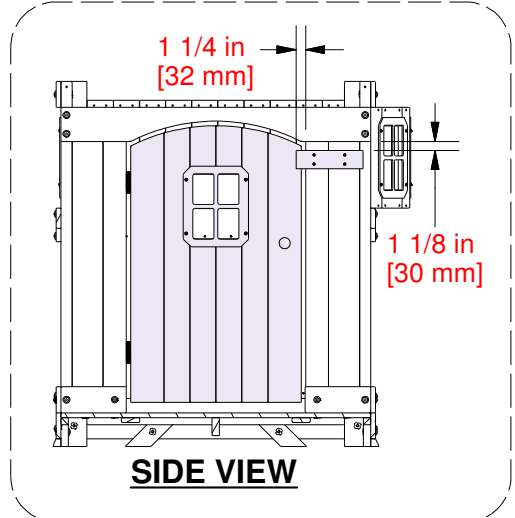
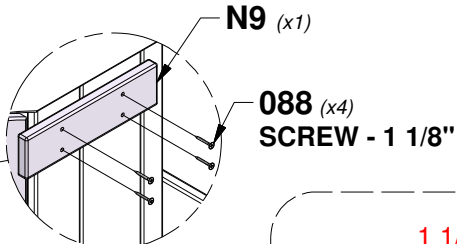
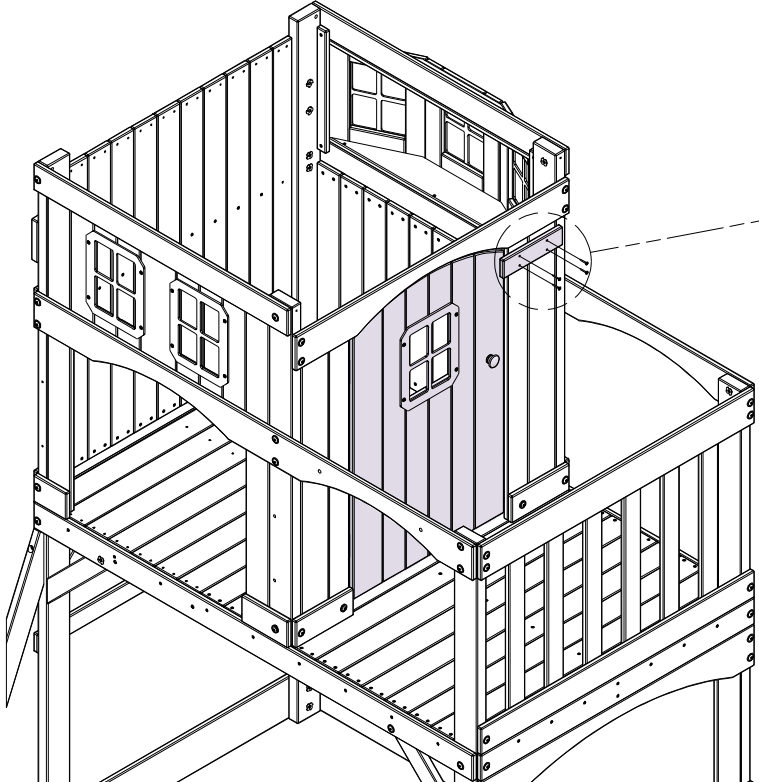
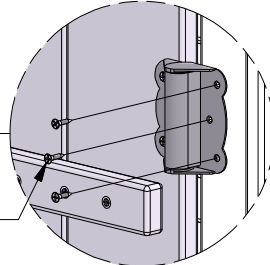
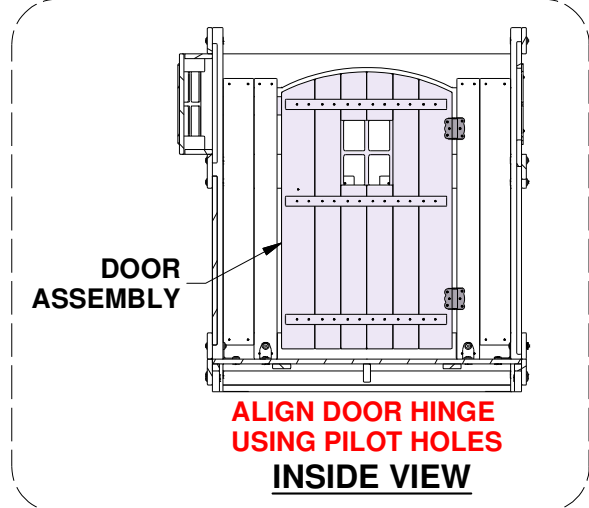
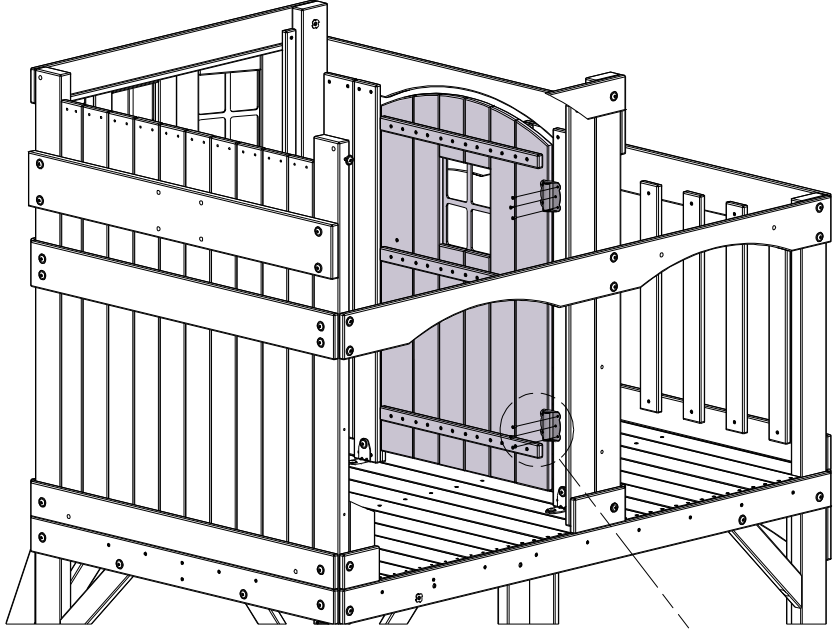

STEP 22 - FORT ASSEMBLY

QTY	PART NUMBER	DESCRIPTION
2	H100398	T-NUT 1/4 BLK
2	H100403	LAG SCREW WH 1/4x1-1/2 BLK
4	H100405	WASHER LOCK EXT 6x15 BLK
2	H101026	BOLT WH 1/4x1-3/4 BLK

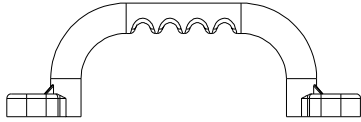

A100028
(x2) | **HAND GRIP GREEN PLASTIC**

TIP:
INSTALL T-NUTS IN WOOD FIRST

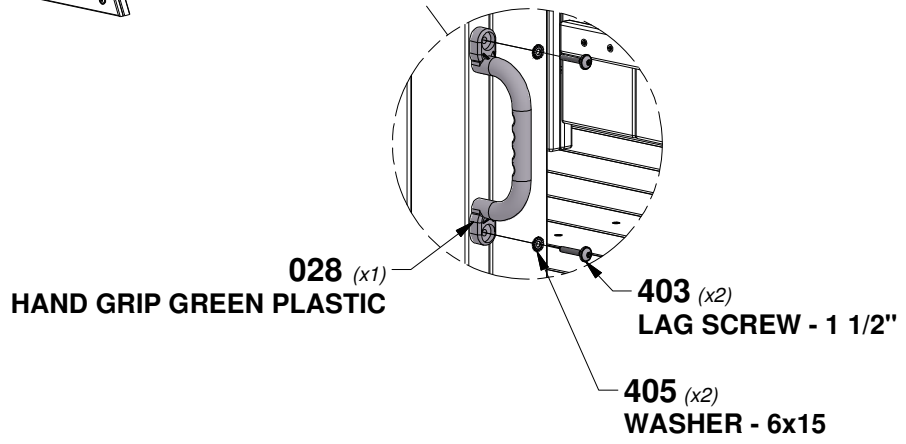
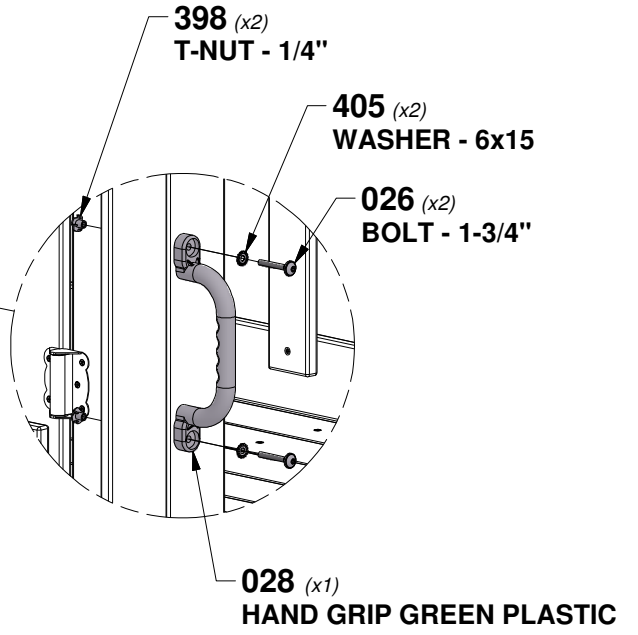
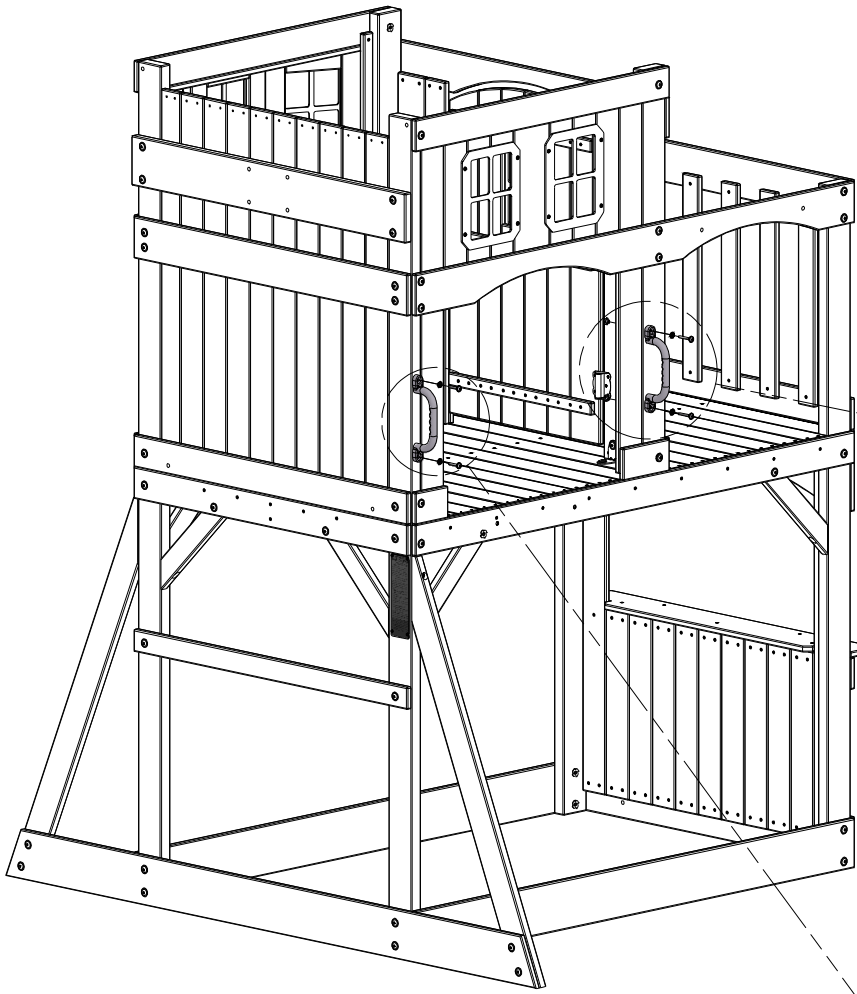

STEP 23 - FORT ASSEMBLY

QTY	PART NUMBER	DESCRIPTION
28	H100088	SCREW PFH 8x1-1/8"
2	H100194	BOLT WH 5/16x2-1/2 BLK
4	H100198	WASHER LOCK EXT 8x19 BLK
2	H100379	T-NUT 5/16 BLK
2	H100458	LAG SCREW WH 5/16x2 BLK

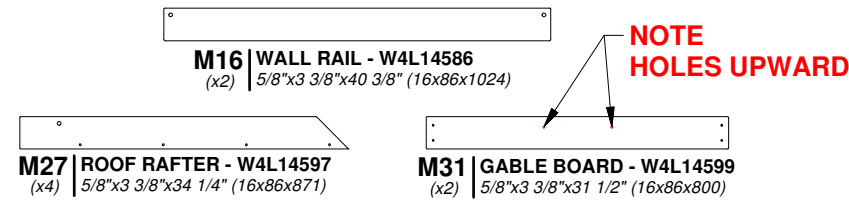

TIP:
INSTALL T-NUTS IN WOOD FIRST

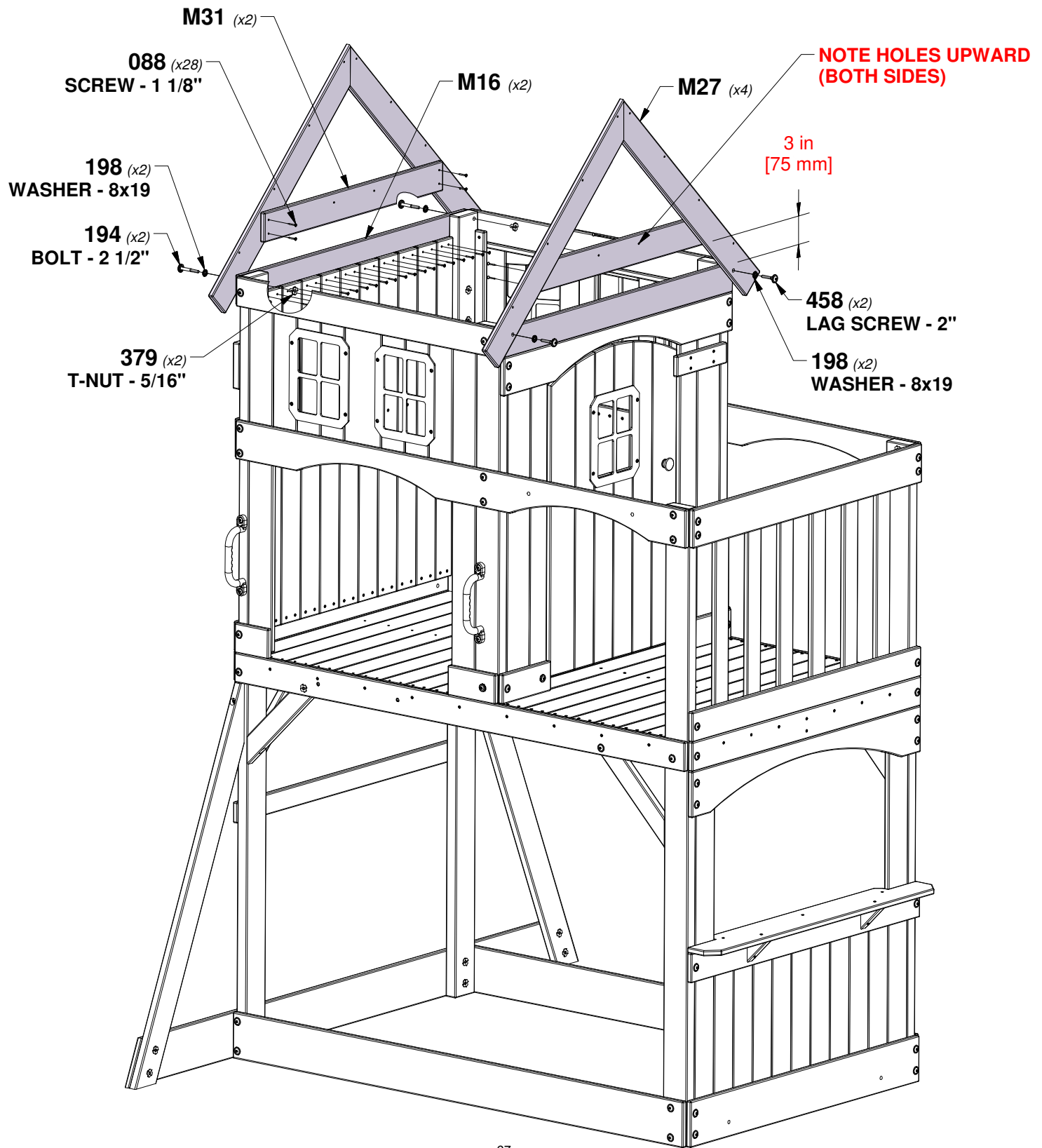

STEP 24 - FORT ASSEMBLY

QTY	PART NUMBER	DESCRIPTION
8	H100070	SCREW PWH 8x3/4
4	H100088	SCREW PFH 8x1-1/8"

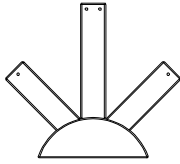

A100361 (x2) | PLASTIC SUNBURST

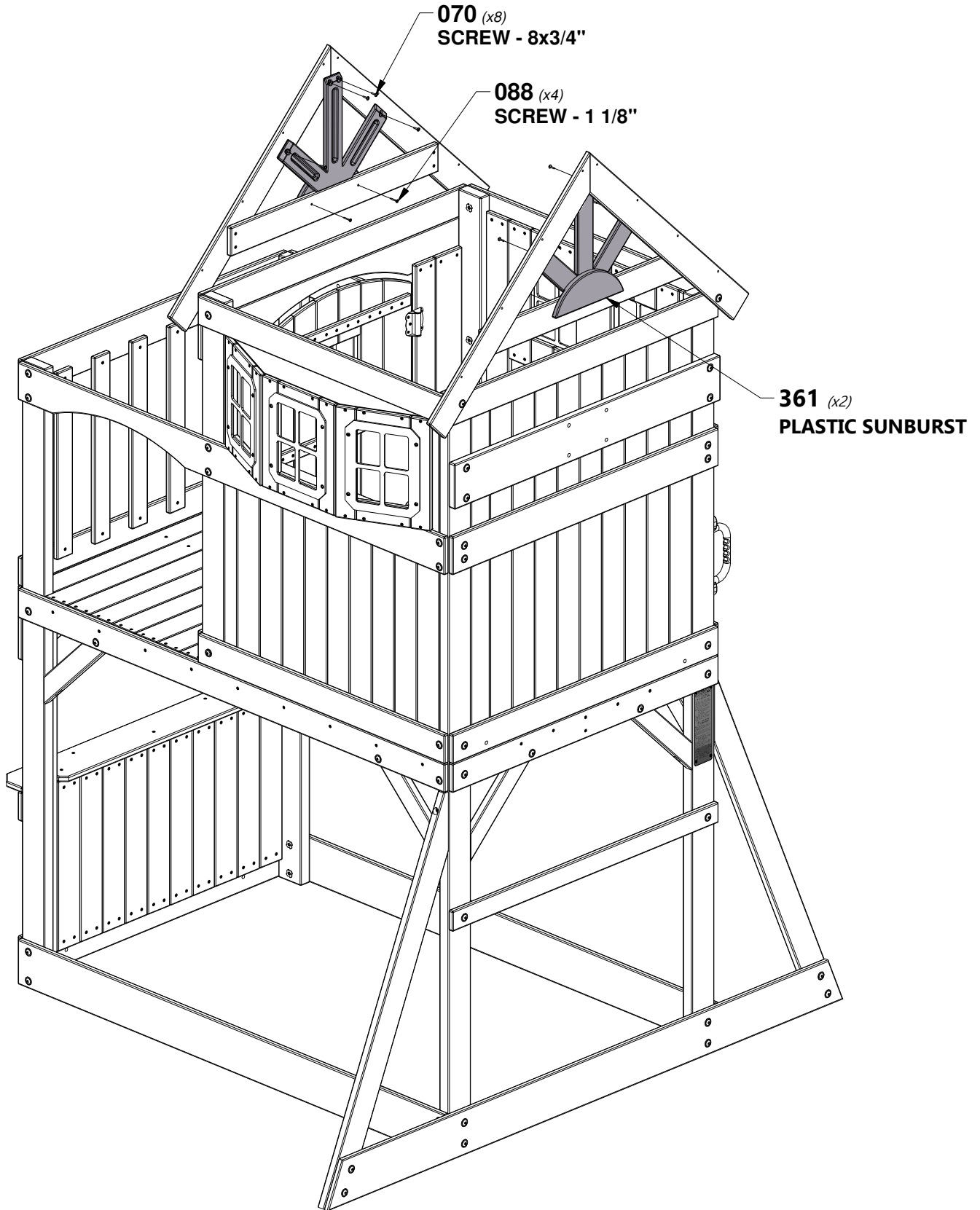

STEP 25 - FORT ASSEMBLY

QTY	PART NUMBER	DESCRIPTION
8	H100086	SCREW PFH 8x1-1/2"

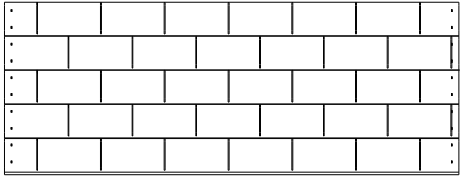

RP2 | ROOF PANEL - W2A03134
 (x2) | 1 1/16"x16 1/8"x42 5/8" (35x410x1083)

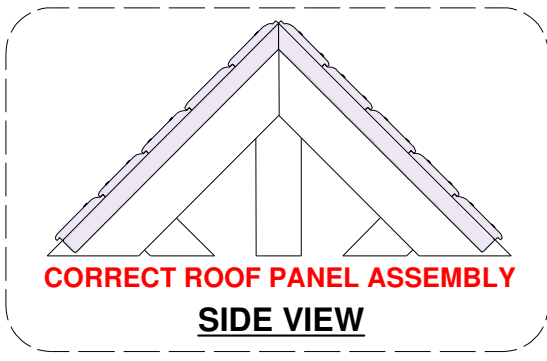
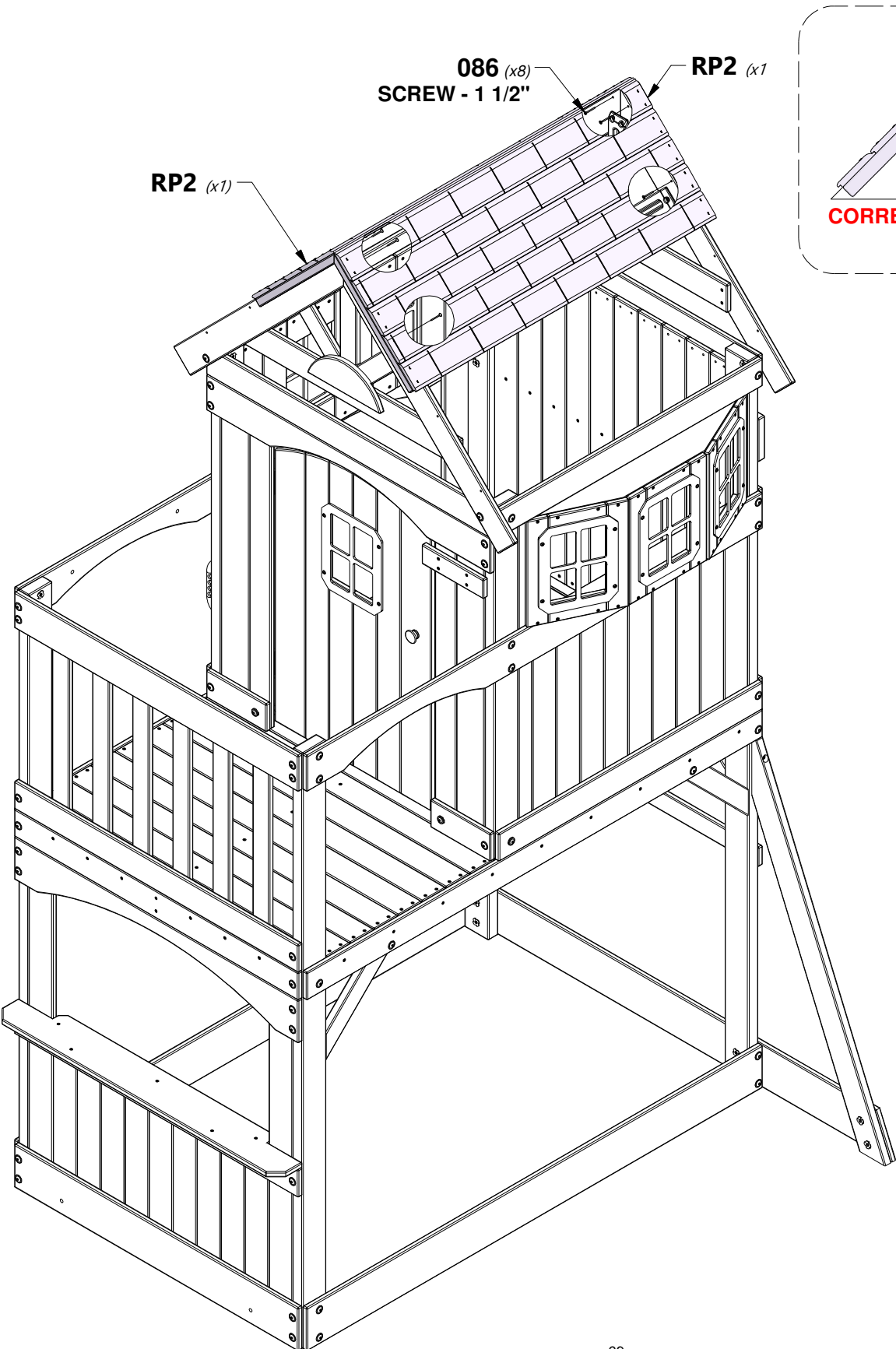

STEP 26 - FORT ASSEMBLY

QTY	PART NUMBER	DESCRIPTION
8	H100086	SCREW PFH 8x1-1/2"

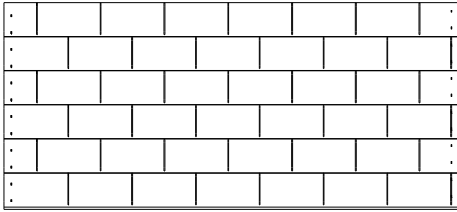

RP1 | ROOF PANEL - W2A03133
(x2) | 1 1/16"x19 5/16"x42 5/8" (35x491x1083)

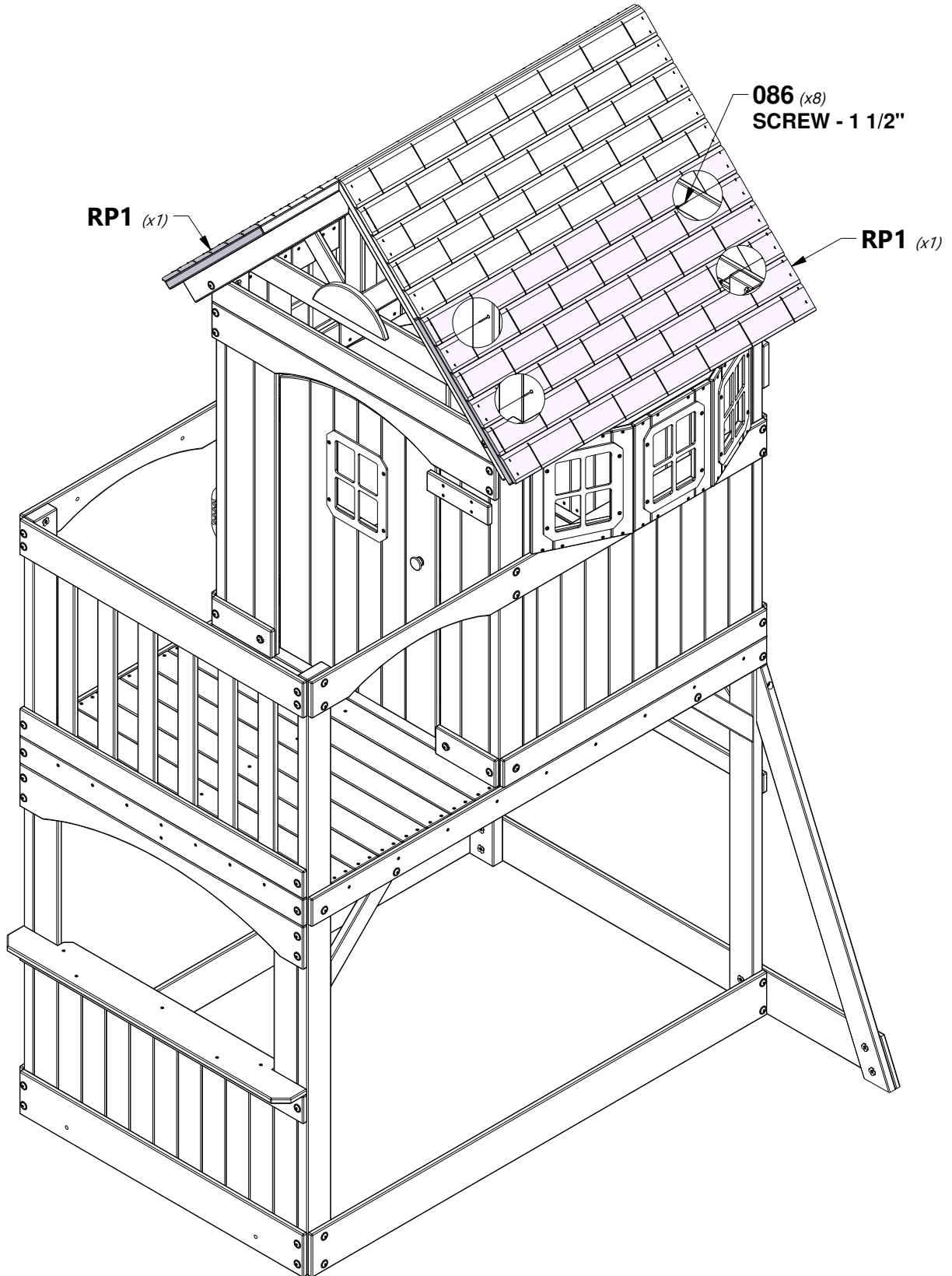

STEP 27 - FORT ASSEMBLY

QTY	PART NUMBER	DESCRIPTION
2	H100379	T-NUT 5/16 BLK
2	H100396	BOLT WH 5/16x1/2 BLK

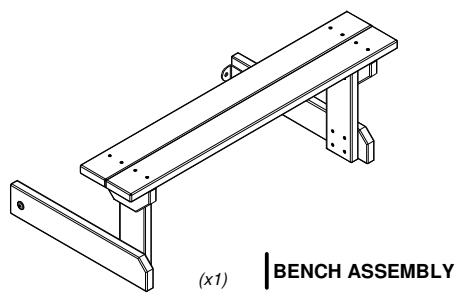

TIP:
INSTALL T-NUTS IN WOOD FIRST

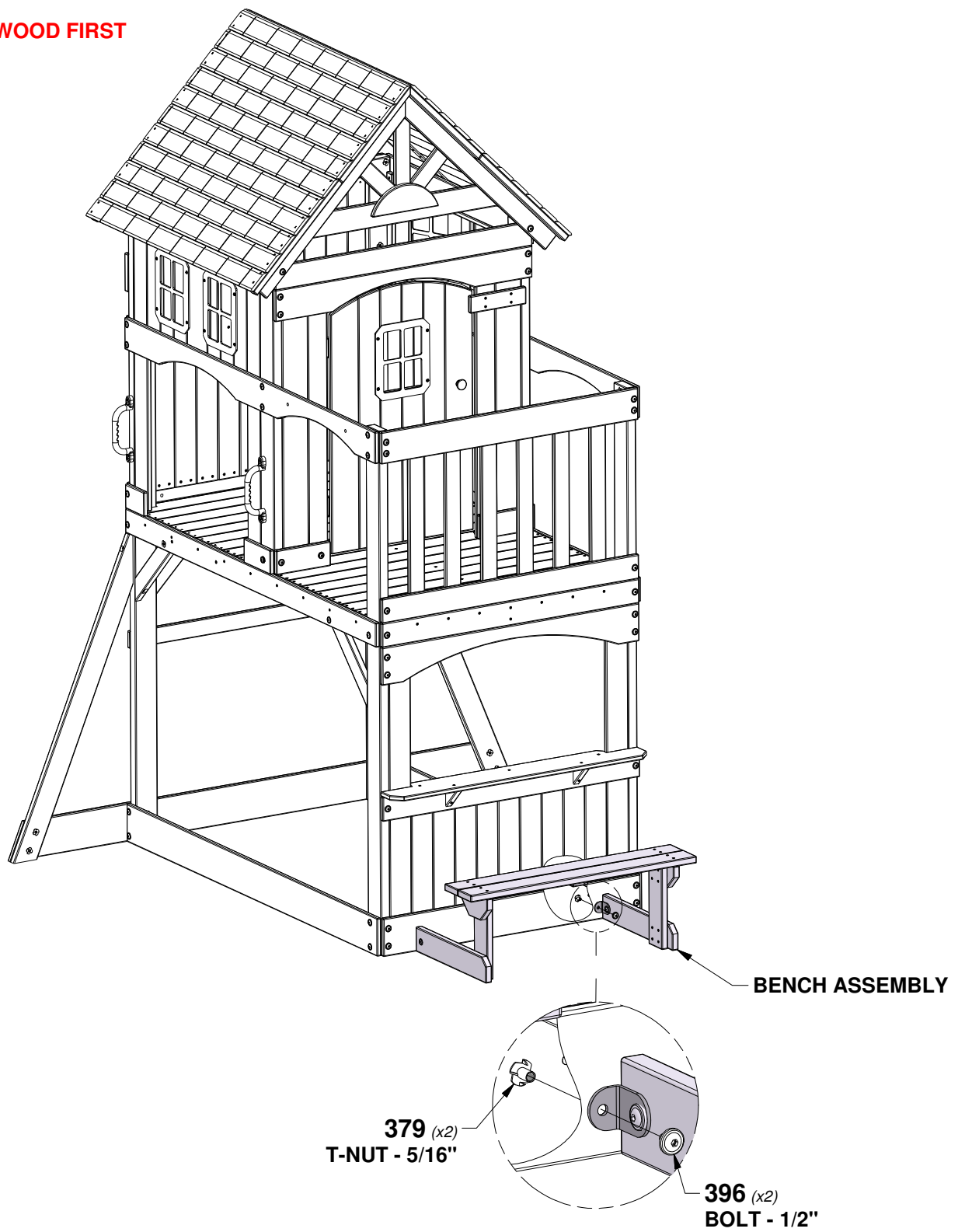

STEP 28 - FORT ASSEMBLY

QTY	PART NUMBER	DESCRIPTION
2	H100089	SCREW PFH 8x1-3/4"
2	H100198	WASHER LOCK EXT 8x19 BLK
2	H100205	BOLT WH 5/16x2-1/4 BLK
2	H100379	T-NUT 5/16 BLK



G2 | WALL RAIL - W4L14611
(x2) | 1"x4 3/8"x40 3/4" (24x112x1034)



M34 | FILLER BOARD - W4L14617
(x1) | 5/8"x1 3/4"x33 1/2" (16x45x851)

TIP:
INSTALL T-NUTS IN WOOD FIRST

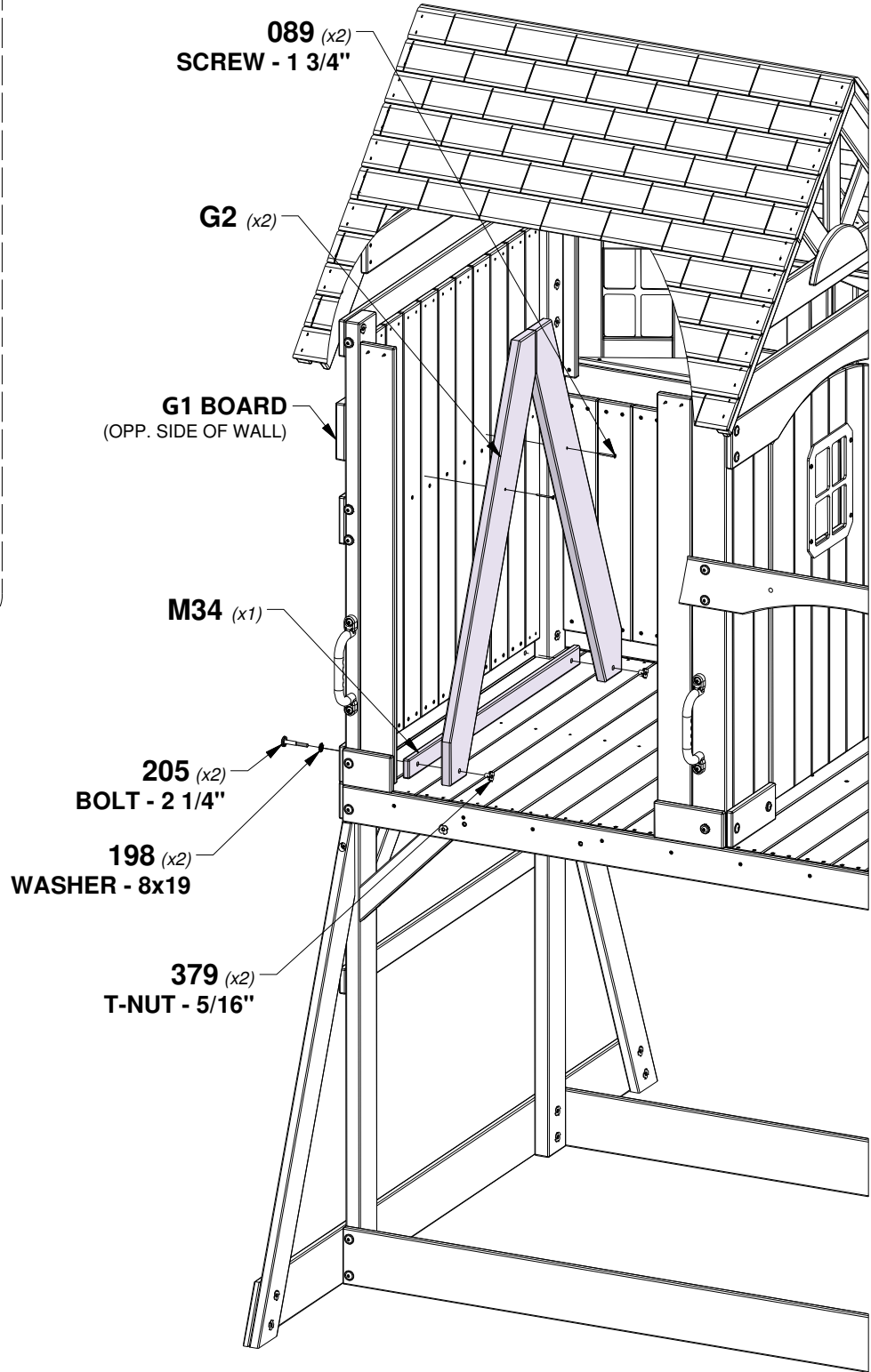
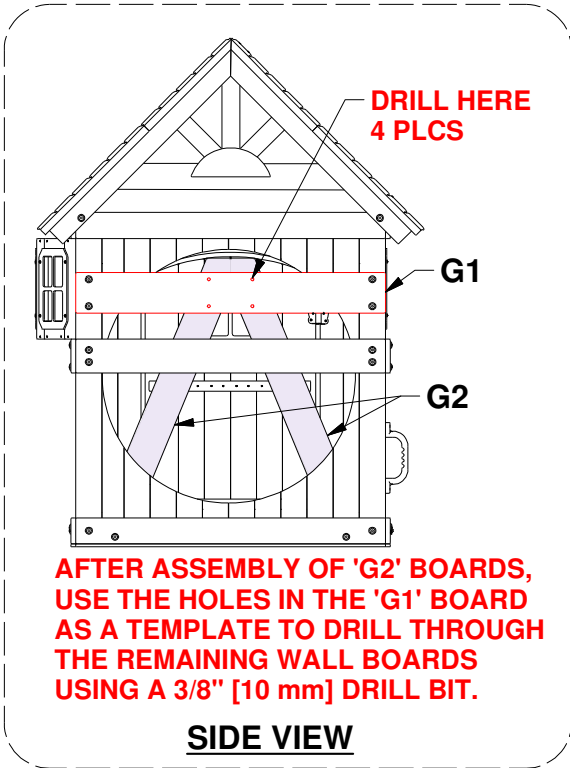

STEP 29 - FORT ASSEMBLY

QTY	PART NUMBER	DESCRIPTION
2	H100198	WASHER LOCK EXT 8x19 BLK
2	H100407	BOLT WH 5/16x1 1/2 BLK

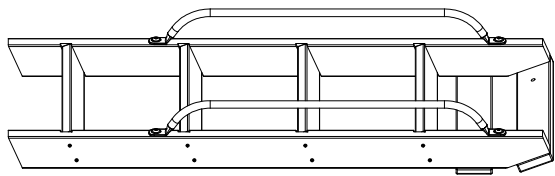

(x1) | LADDER ASSEMBLY

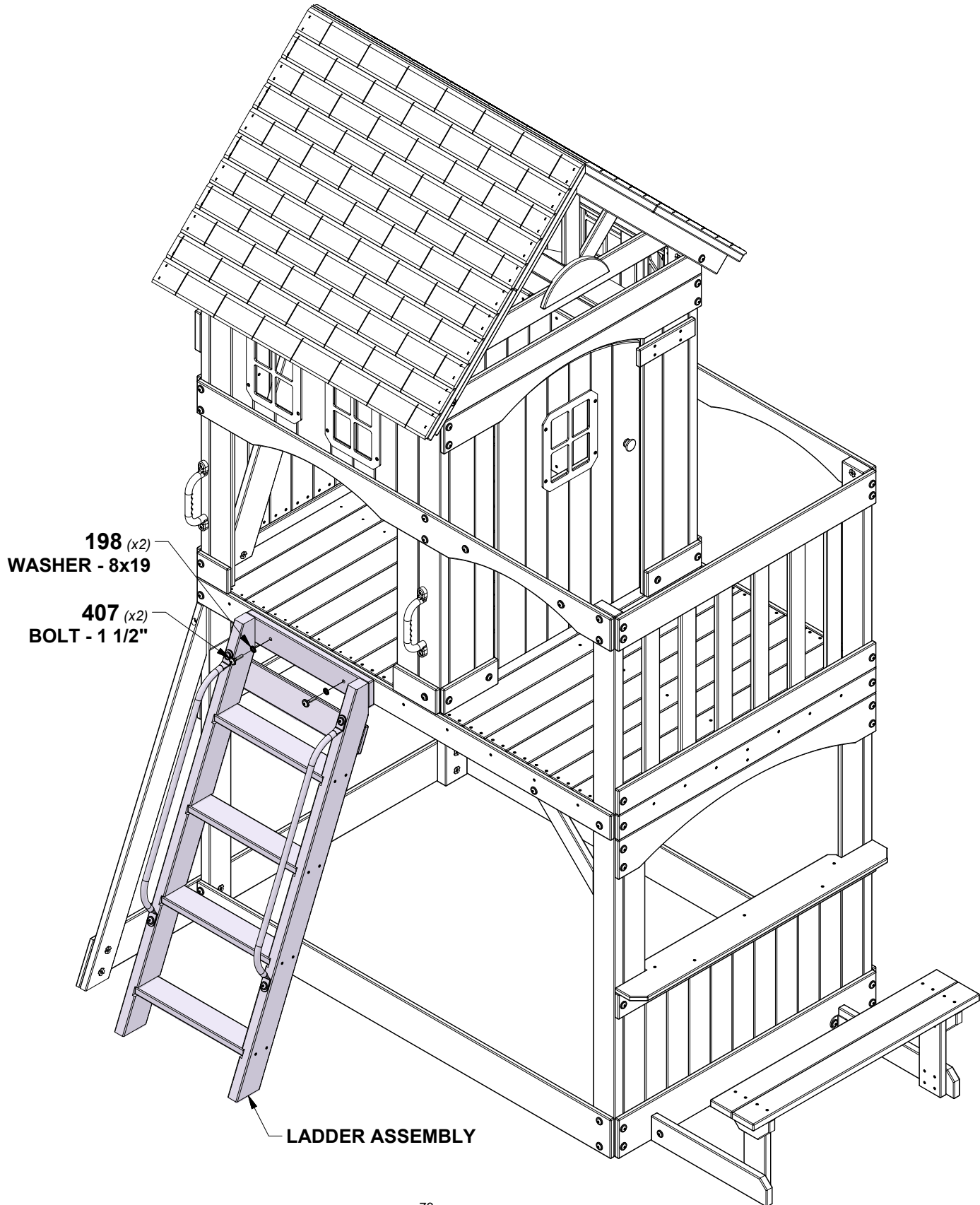

STEP 30 - FORT ASSEMBLY

QTY	PART NUMBER	DESCRIPTION
2	H100379	T-NUT 5/16 BLK
2	H100396	BOLT WH 5/16x1/2 BLK

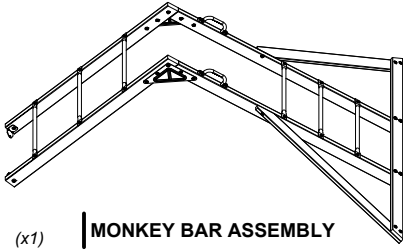

TIP:
INSTALL T-NUTS IN WOOD FIRST

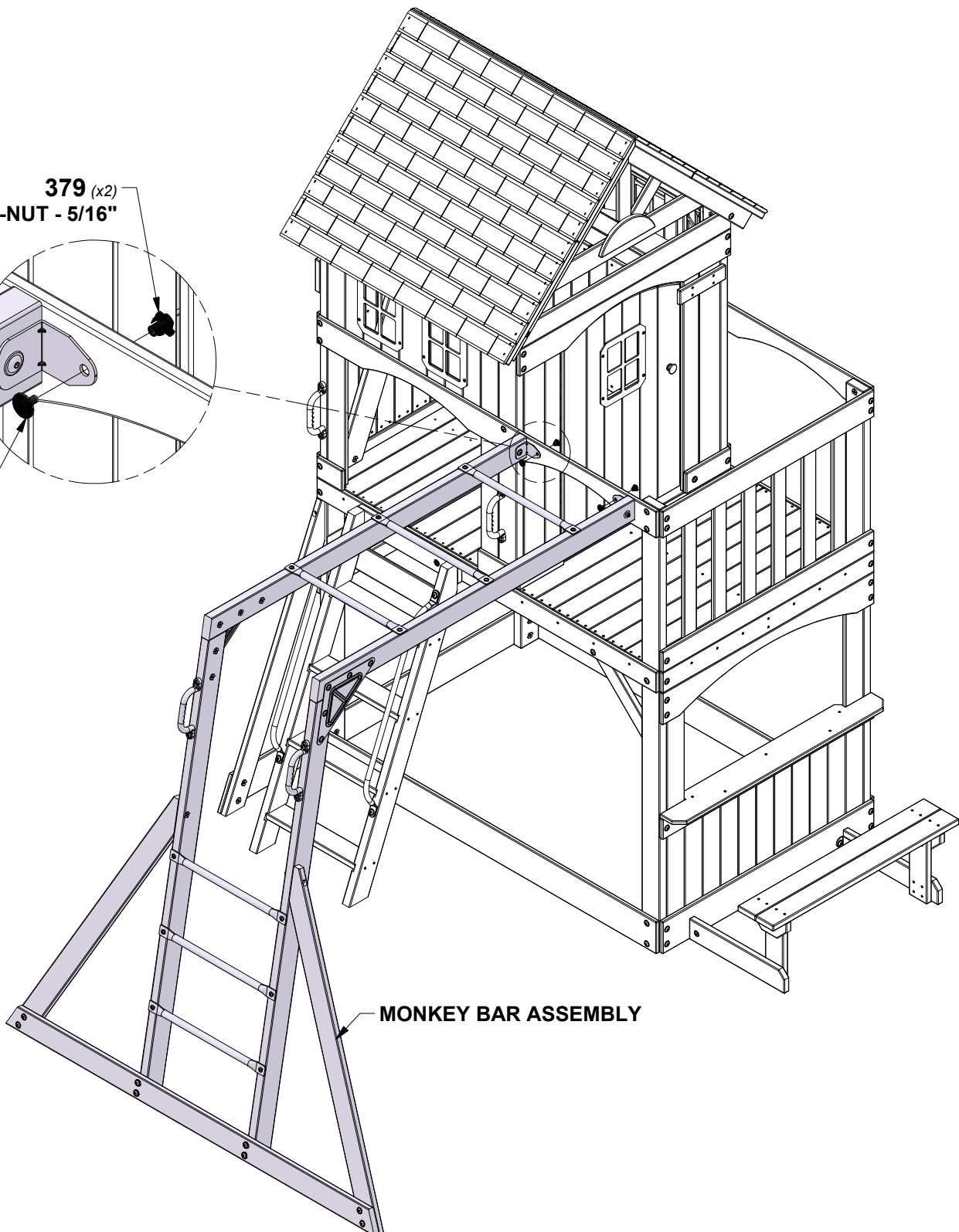
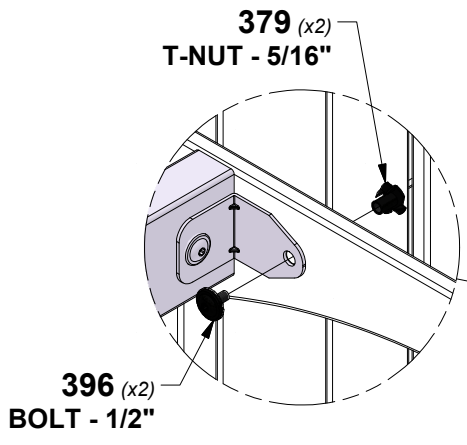

STEP 31 - FORT ASSEMBLY

QTY	PART NUMBER	DESCRIPTION
4	H100379	T-NUT 5/16 BLK
4	H100472	BOLT HEX 5/16x2-3/4 BLK
4	H100477	WASHER SPLIT 5/16 BLK
4	H100478	WASHER FLAT 8x27 BLK

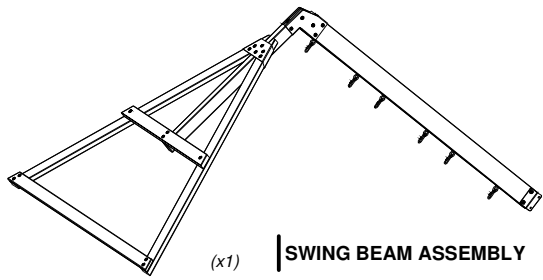

TIP:
INSTALL T-NUTS IN WOOD FIRST

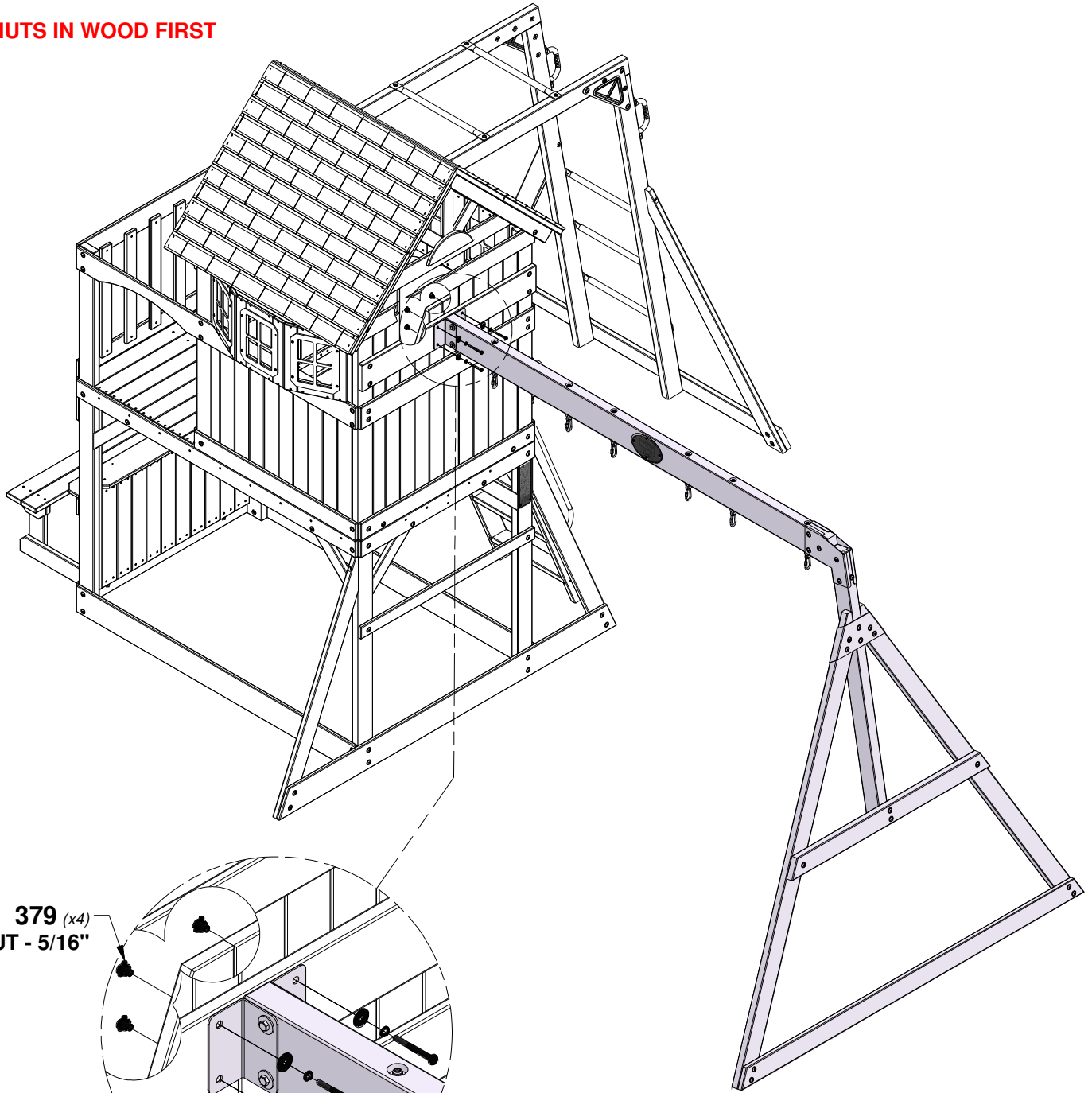

379 (x4)
T-NUT - 5/16"

478 (x4)
WASHER - 8x27

472 (x4)
BOLT - 2 3/4"

477 (x4)
WASHER - 5/16

STEP 32 - FORT ASSEMBLY

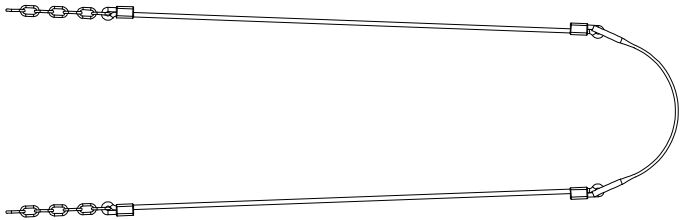

A6P00397 | ROPE-CHAIN GREEN / SEAT GREEN
(x2)

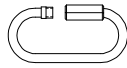

A100069 | QUICK LINK
(x2)

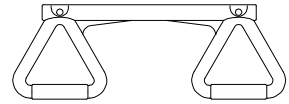

A6P00034 | TRAPEZE YELLOW
(x1)



A100083 | ROPE-CHAIN GREEN 33"
(x2)

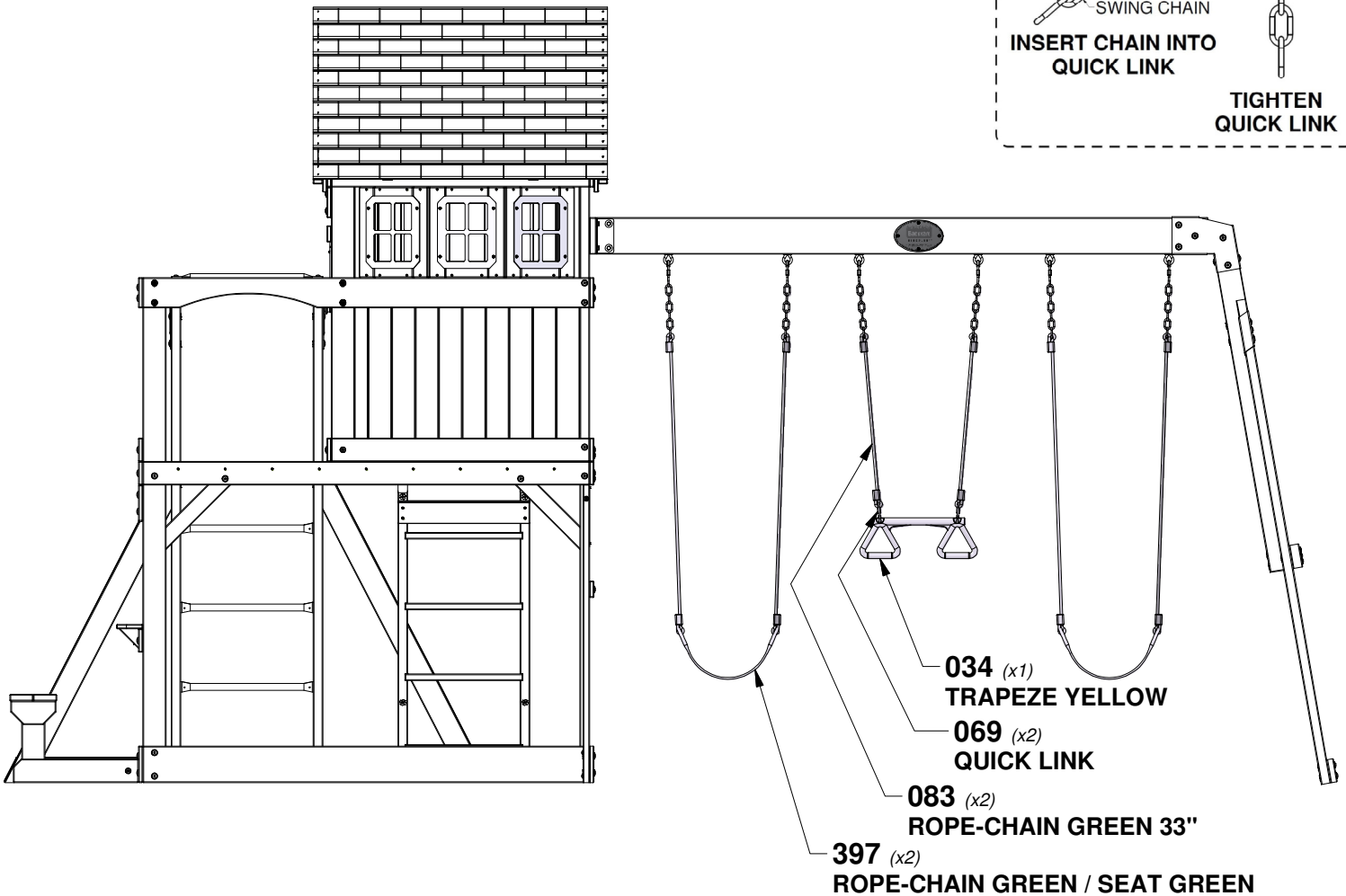
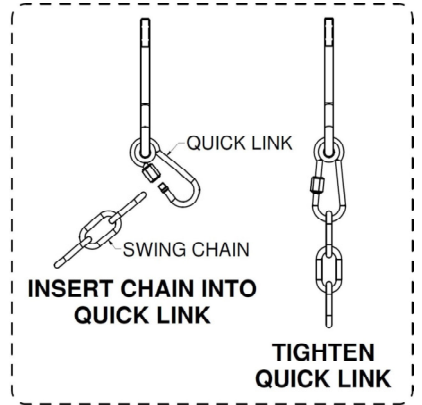

STEP 1 - SLIDE ASSEMBLY

QTY	PART NUMBER	DESCRIPTION
3	H100074	T-NUT 5/16
3	H100115	BOLT WH 5/16x1/2

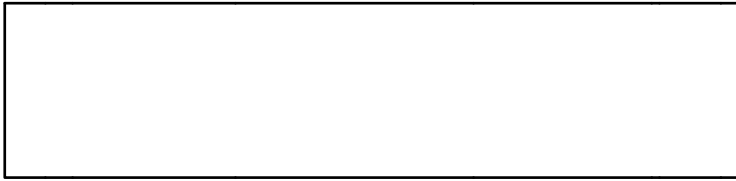

A100356
(x1) | **SLIDE BED 8' LIGHT GREEN**

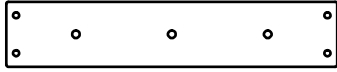

M77
(x1) | **SLIDE BRACE - W4L08748**
5/8"x3 3/8"x17 1/4" (16x86x438)

NOTE: TAKE NOTE OF SLIDE BED SURFACE FINISH, THE DULL SIDE WILL BE TOWARDS THE GROUND. PLACE SLIDE BRACE CENTERED ON THE BOTTOM (DULL SIDE) AND 1/2" FROM THE EDGE. USE M77 BOARD AS A TEMPLATE FOR DRILLING BOTTOM HOLE PATTERN IN SLIDE BED. USE A 3/8" DRILL BIT.

TOP

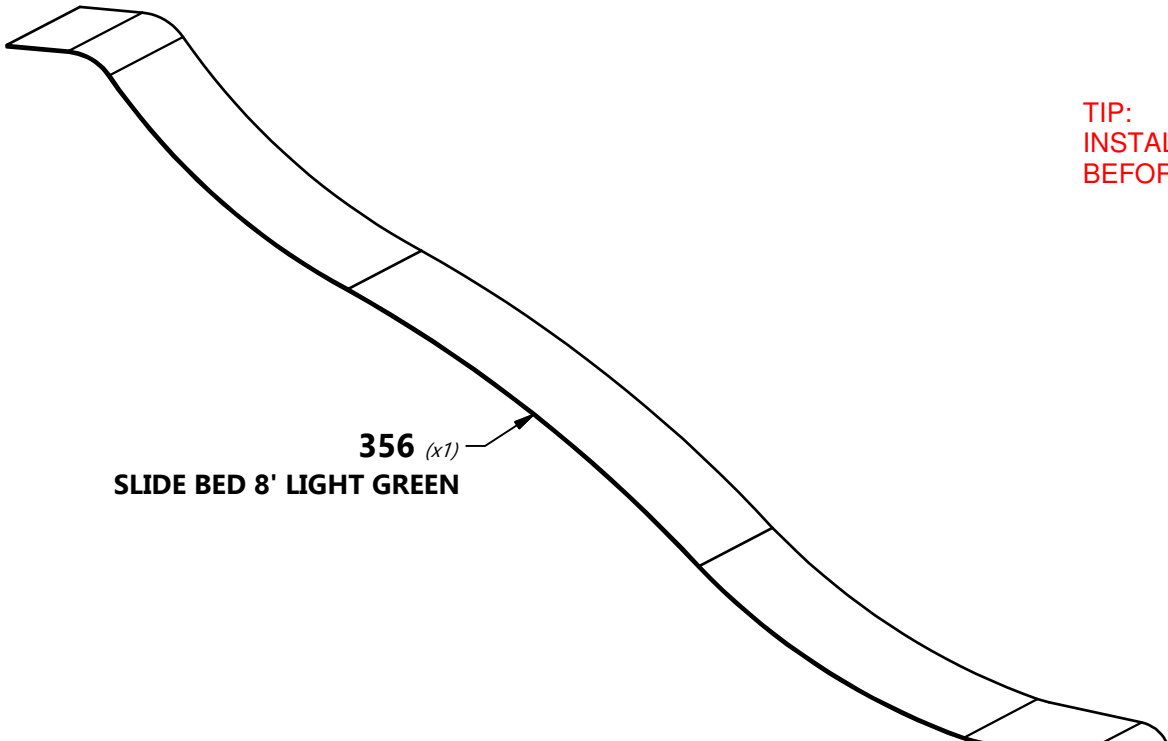

TIP:
INSTALL T-NUTS INTO BOARDS
BEFORE ASSEMBLY

TIP:
PREBENDING THE ENDS WILL EASE ASSEMBLY.
PLACING THE SLIDE BED OUT IN THE SUN MAKES
IT EASIER TO BEND.

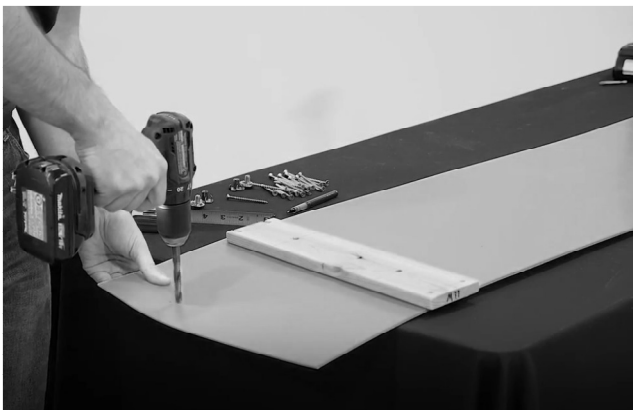
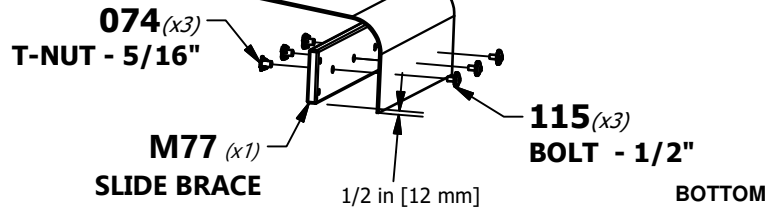

STEP 2 - SLIDE ASSEMBLY

QTY	PART NUMBER	DESCRIPTION
24	H100090	SCREW PFH 8x2 1/2



M78 | CENTER SLIDE BRACE - W4L08749
(x2) | 5/8"x3 3/8"x17 1/4" (16x86x438)

NOTE:

PLACE THE SLIDE RAIL ON FLAT SURFACE. STARTING AT THE BOTTOM, INSERT THE SLIDE BED INTO THE CHANNEL ON THE INSIDE OF THE RAIL. HOLD THE SLIDE BED IN PLACE WHILE A HELPER BENDS THE SLIDE BED INTO THE CHANNEL. MAKE SURE THE SLIDE BED IS COMPLETELY INSERTED INTO THE CHANNEL.

INSERT THE TWO CENTER SLIDE BRACES INTO THEIR RESPECTIVE LOCATIONS. SECURE THE SLIDE BED AND CENTER USING THE PROVIDED HARDWARE.

USING A 1/8" DRILL BIT, DRILL PILOT HOLES IN EACH INDENTATION ALONG EACH SIDE RAIL. THERE SHOULD BE 12 INDENTIONS ON EACH RAIL.

REPEAT THIS PROCESS FOR THE OPPOSITE SLIDE RAIL.



FAILURE TO INSERT SLIDE BED PROPERLY MAY RESULT IN INJURY OR AMPUTATION. EXPOSED SLIDE EDGES CAN BE SHARP AND BECOME A LACERATION HAZARD IF THE SLIDE IS NOT PROPERLY ASSEMBLED.

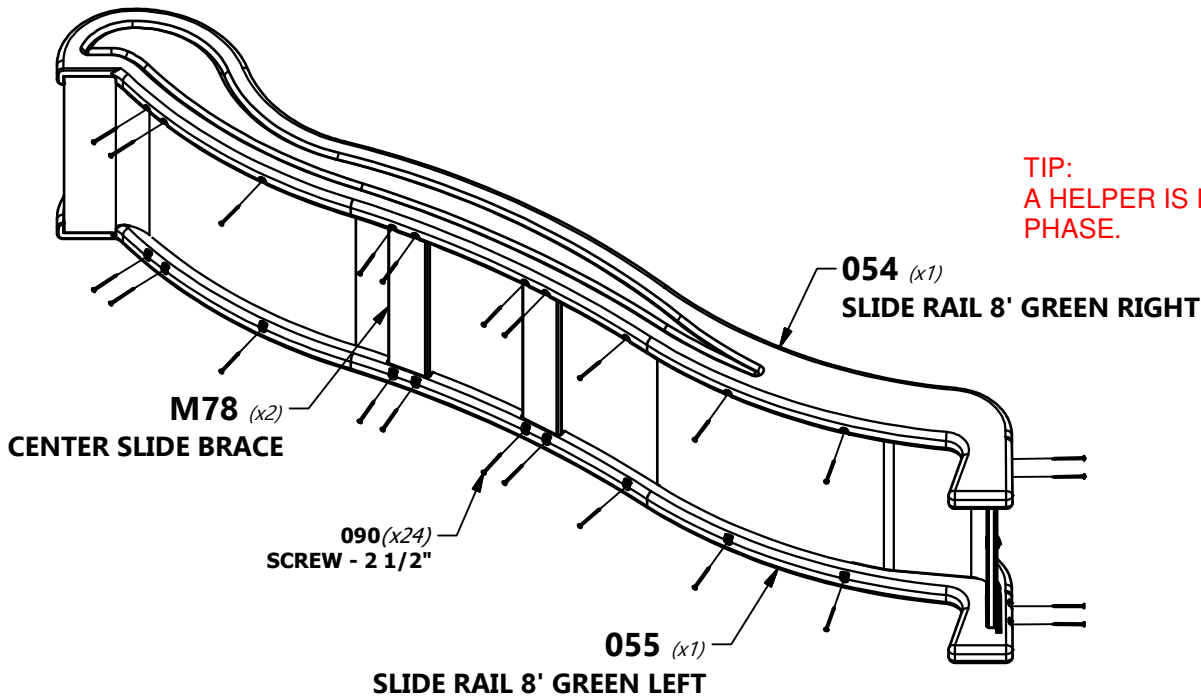

TIP:
A HELPER IS REQUIRED FOR THIS PHASE.



STEP 33 - FORT ASSEMBLY

QTY	PART NUMBER	DESCRIPTION
3	H100074	T-NUT 5/16
3	H100115	BOLT WH 5/16x1/2

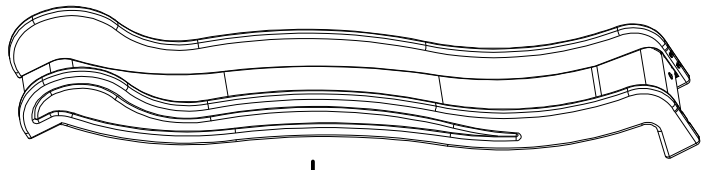

(x1) | SLIDE ASSEMBLY

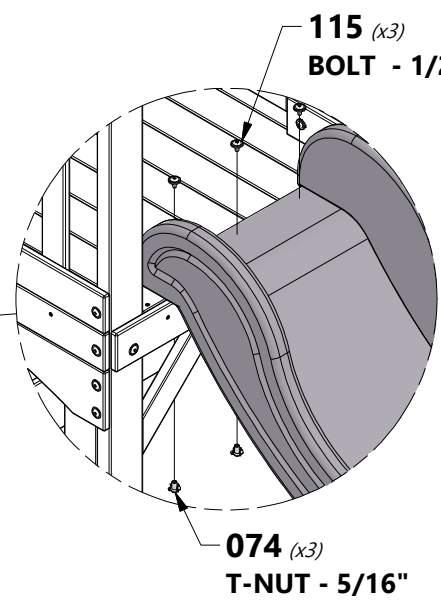
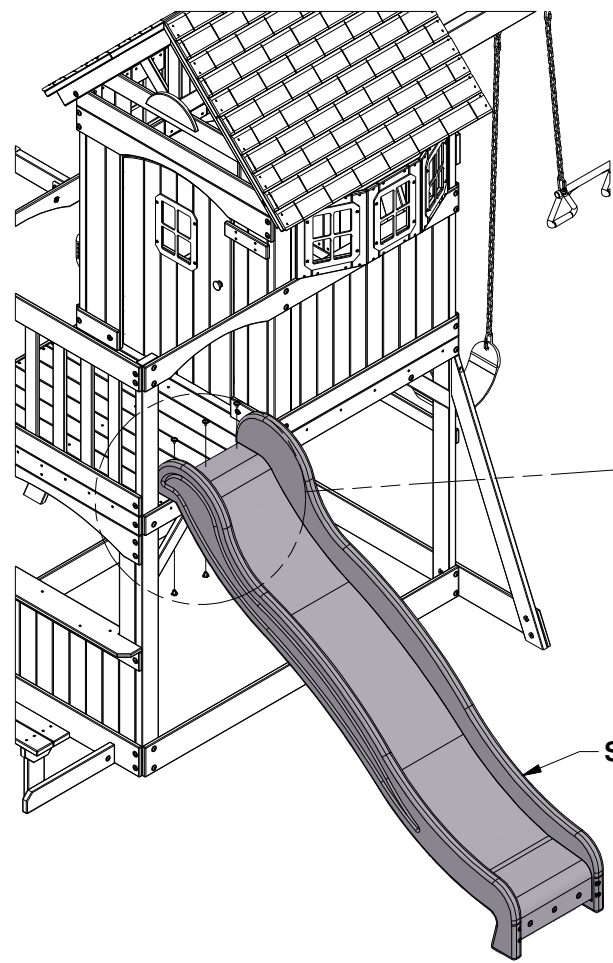
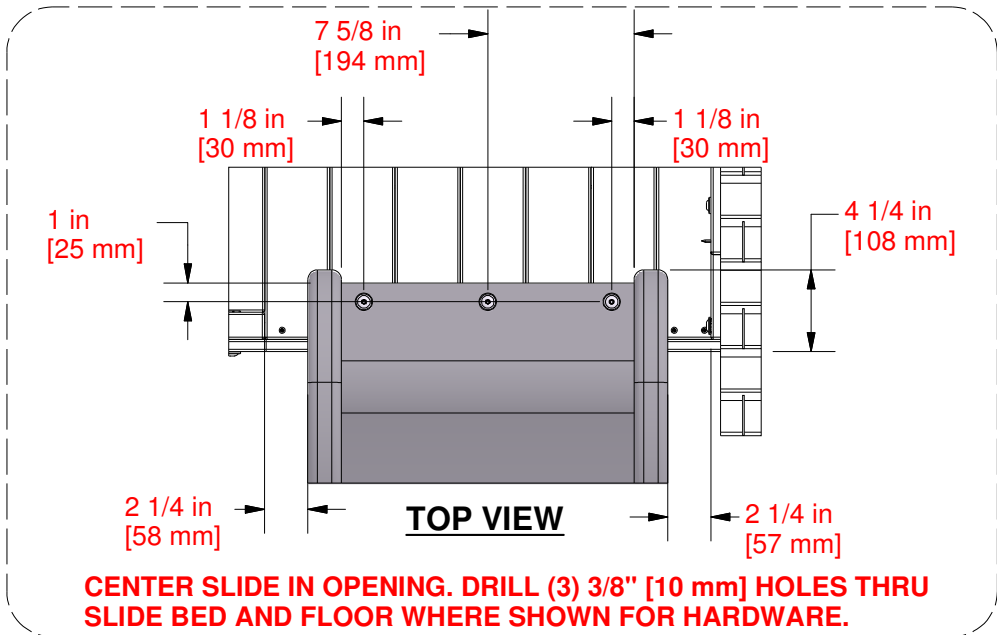

SLIDE ASSEMBLY

115 (x3)
BOLT - 1/2"

074 (x3)
T-NUT - 5/16"

STEP 34 - FORT ASSEMBLY

QTY	PART NUMBER	DESCRIPTION
8	H100199	WASHER LOCK EXT 12x19 BLK
4	H100468	BOLT WH 5/16x1 BLK
8	H100469	NUT BARREL WH 5/16x5/8 BLK
4	H100663	BOLT WH 5/16x3/4 BLK



DETAIL (B)

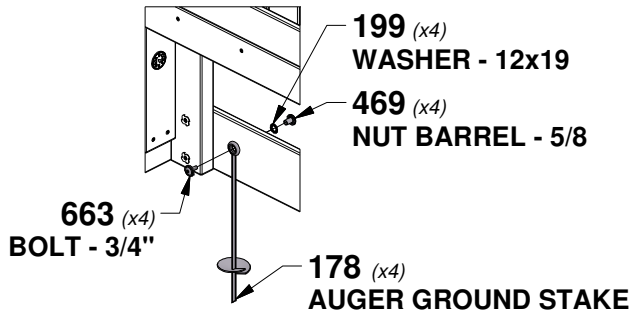

TWIST GROUND STAKE (178) INTO GROUND AT LOCATIONS SHOWN. USING GROUND STAKE AS A GUIDE, DRILL A 3/8" [10mm] HOLE FOR HARDWARE.

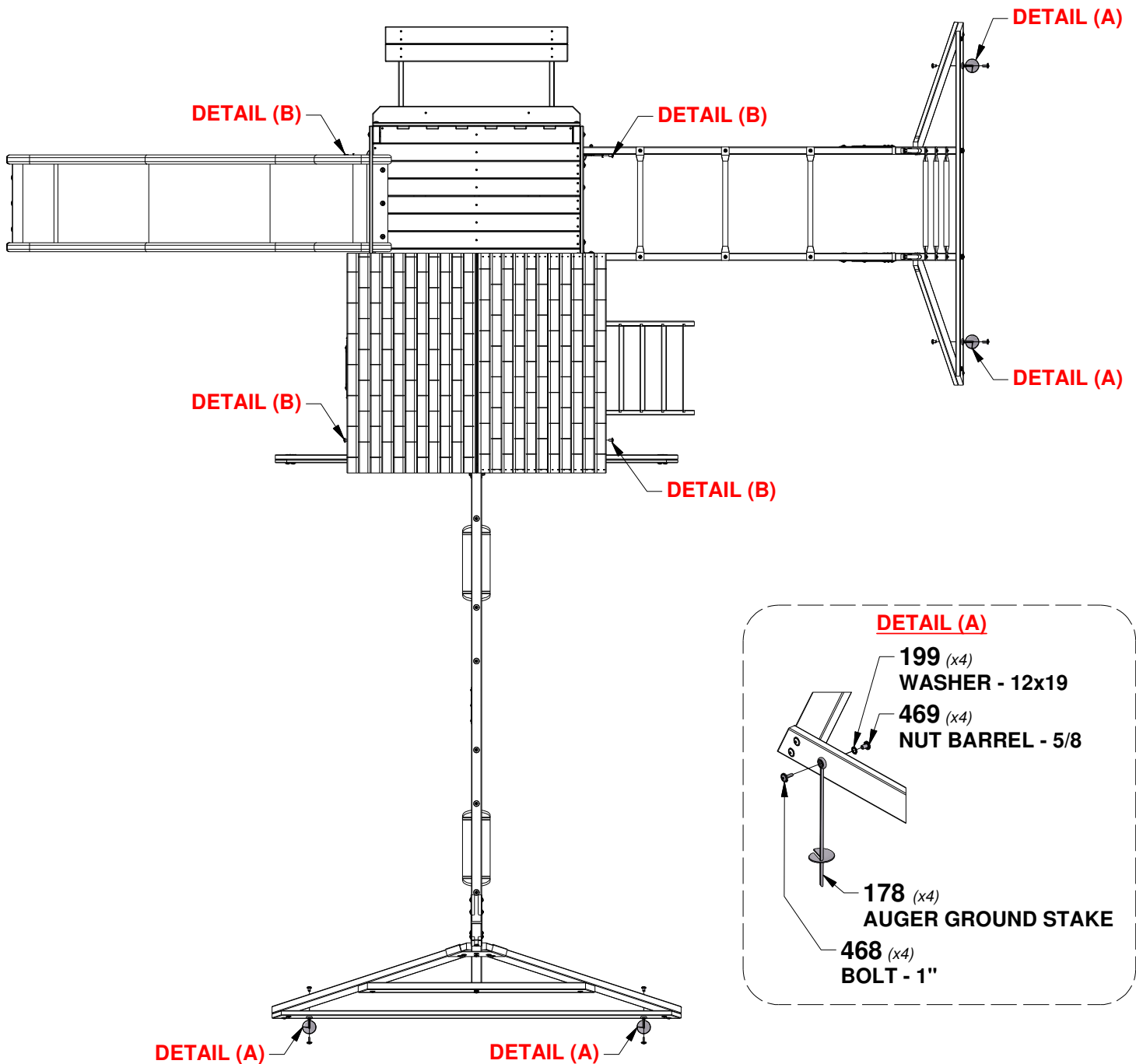

DETAIL (A)

