



# ASSEMBLY INSTRUCTIONS

Pour le français, voir la page 2. Para el español, ver la página 3.

## 10' x 8' OUTDOOR STORAGE SHED MODEL 60330

### BEFORE ASSEMBLY:

- Assemble on a level platform
- At least 3 people recommended for setup

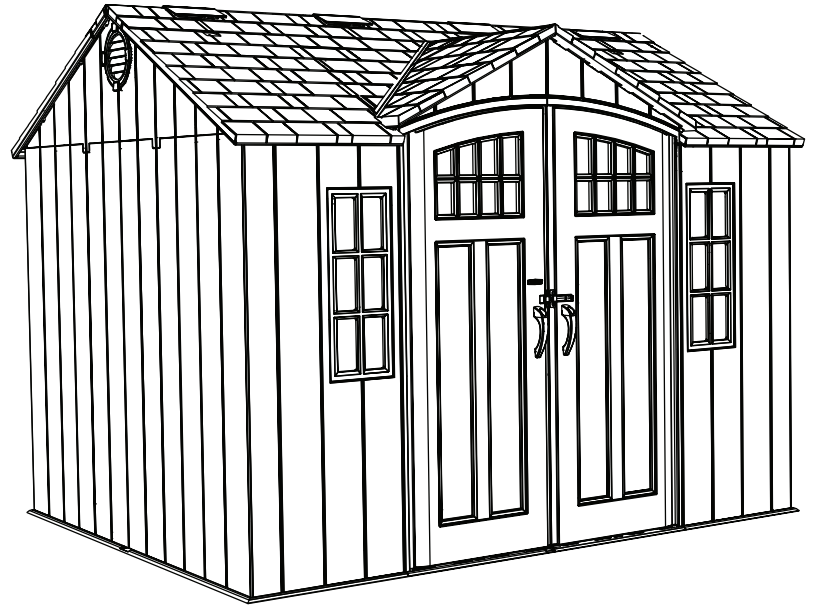

**FOR DOMESTIC USE ONLY!**  
**IMPORTANT: RETAIN FOR FUTURE REFERENCE. READ CAREFULLY.**

### TOOLS REQUIRED



### TABLE OF CONTENTS

Icon Legend.....	4
Warnings & Notices.....	5
Platform Construction.....	6
Truss Assembly.....	11
Gable Assembly.....	21
Door Assembly.....	26
Floor Assembly.....	39
Wall Assembly.....	44
Parts Identifier.....	47
Shelving Installation.....	59
Roof Assembly.....	62
Wall Hook Installation.....	81
Door Alignment.....	83
Anchoring.....	86
Cleaning & Care.....	91
Registration.....	92
Warranty.....	93

### QUESTIONS?

### CONTACT LIFETIME CUSTOMER SERVICE:

Call: 1-800-225-3865

Live Chat: [www.lifetime.com/customerservice](http://www.lifetime.com/customerservice)  
 (click on "LIVE CHAT" tab)

For Customer Service in mainland Europe:  
 E-mail: [csinternationa@lifetime.com](mailto:csinternationa@lifetime.com)

**MODEL# AND PRODUCT ID** (both are needed when contacting us)  
 Model Number: 60330  
 Product ID:



# INSTRUCTIONS D'ASSEMBLAGE

For English, see page 1. Para el español, ver la página 3.

## ABRI EXTÉRIEUR DE 3,05 m x 2,44 m

MODÈLE n° 60330

### AVANT L'ASSEMBLAGE :

- Assembler sur une plate-forme nivelée
- Nous recommandons, au moins, 3 adultes pour l'assemblage

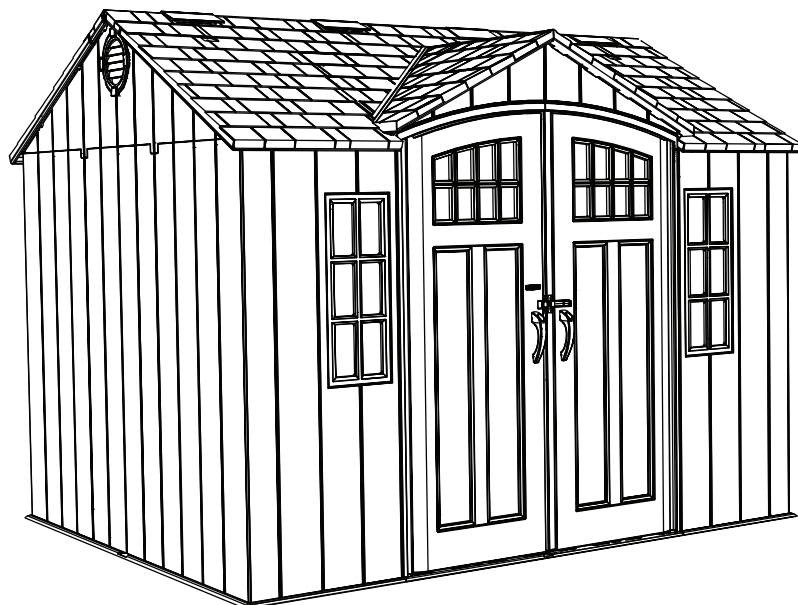

## POUR USAGE DOMESTIQUE SEULEMENT ! IMPORTANT, CONSERVER CES INSTRUCTIONS POUR RÉFÉRENCE : LIRE AVEC PRUDENCE !

### OUTILS REQUIS



### SOMMAIRE

Légende des icônes.....	4
Avertissements et avis.....	5
Assemblage de la plate-forme.....	6
Assemblage des fermes.....	11
Assemblage des pignons.....	21
Assemblage des portes.....	26
Assemblage du plancher.....	39
Assemblage des murs.....	44
Identificateur des pièces.....	47
Installation du rayonnage.....	59
Assemblage du toit.....	62
Installation des crochets muraux.....	81
Alignement des portes.....	83
L'ancrage de l'abri.....	86
Nettoyage et entretien.....	91
Enregistrement.....	92
Garantie.....	94

### QUESTIONS ?

### CONTACTER LES SERVICES À LA CLIENTÈLE LIFETIME® :

Composer le 1-800-225-3865

Entretien en direct: [www.lifetime.com/customerservice](http://www.lifetime.com/customerservice)  
(cliquer sur la languette « LIVE CHAT »)

Pour les services à la clientèle du continent européen : N° de modèle : 60330

É-mail : [csinternational@lifetime.com](mailto:csinternational@lifetime.com)

N° DE MODÈLE ET RÉFÉRENCE DU PRODUIT (Il faut avoir les deux au moment de nous contacter)

N° de modèle : 60330

Référence du produit :



# INSTRUCCIONES DE ENSAMBLAJE

For English, see page 1. Pour le français, voir la page 2.

## CASETA EXTERIOR DE 3,05 m x 2,44 m

MODELO n° 60330

### ANTES DE ENSAMBLAR:

- Ensamblar sobre una plataforma nivelada
- Recomendamos, por lo menos, 3 adultos para el ensamblaje

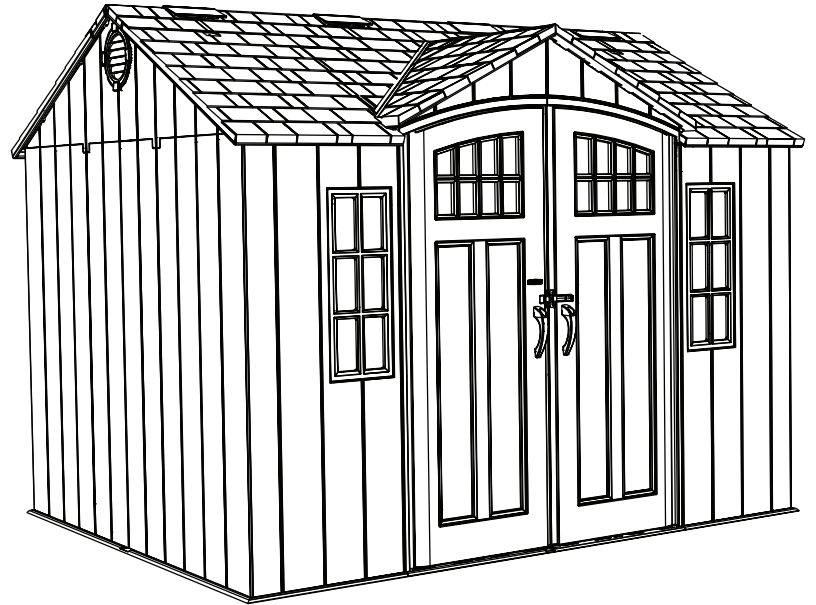

**¡SÓLO PARA USO DOMÉSTICO!**  
**¡IMPORTANTE: GUARDAR PARA FUTURA REFERENCIA. LEER CUIDADOSAMENTE!**

### INSTRUMENTAL REQUERIDO



### ÍNDICE

Leyenda de íconos.....	4
Advertencias y avisos.....	5
Ensamblaje de la plataforma.....	6
Ensamblaje de las cerchas.....	11
Ensamblaje de las fachadas.....	21
Ensamblaje de las puertas.....	26
Ensamblaje del piso.....	39
Ensamblaje de los muros.....	44
Identificador de piezas.....	47
Instalación de los estantes.....	59
Ensamblaje del tejado.....	62
Instalación des accesorios.....	81
Alineación de las puertas.....	83
Anclaje de la caseta.....	86
Limpieza y cuidado.....	91
Registro.....	92
Garantía.....	95

### ¿PREGUNTAS?

**PONERSE EN CONTACTO CON LOS SERVICIOS DE CLIENTES LIFETIME®:**

Marcar : 1-800-225-3865

Chat en vivo: [www.lifetime.com/customerservice](http://www.lifetime.com/customerservice)  
(clicar en la lengüeta «LIVE CHAT»)

Para el servicio a clientes en el continente europeo:

Correo electrónico: [csinternational@lifetime.com](mailto:csinternational@lifetime.com)

**MODEL E ID DEL PRODUCTO** (se necesitan los dos al contactarnos)

Número de modelo: 60330

ID del producto:



## ICON LEGEND / LÉGENDE DES ICÔNES / SIGNIFICADO DE LOS ÍCONOS



- Indicates special heed should be taken when reading.
- Indique qu'une attention spéciale doit être portée à la lecture.
- Indica que uno debe prestar atención al leer.

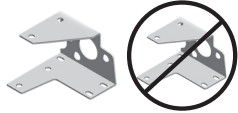

- Indicates the parts/no parts required for a section.
- Indique les pièces à utiliser/qu'aucune pièce n'est requise pour une section.
- Indica las piezas que se usarán/que no necesitan en una sección.



- Indicates the hardware to be used for a section.
- Indique la quincaillerie à utiliser pour une section.
- Indica los artículos de ferretería que se usarán para una sección.



- Indicates no hardware required for a specific page or section.
- Indique qu'aucun matériel n'est requis pour une page précise.
- Indica que no se necesitan los artículos de ferretería para una página específica.



- Indicates the tools to be used for a section.
- Indique les outils à utiliser pour une section.
- Indica las herramientas que se utilizarán para una sección.



- Indicates to use/not use an electric drill for a specific step.
- Indique quand utiliser une/que ne pas utiliser de perceuse électrique pour une étape précise.
- Indica la utilización de/que no utilizar un taladro eléctrico para un paso específico.



- These nuts are centerlock nuts. They are designed to be tight; therefore, they will be harder to tighten. Tighten until flush with the metal or plastic.
- Ces écrous sont des écrous de blocage central. Ils sont conçus pour être serrés; de ce fait, ils seront plus difficiles à resserrer. Serrer jusqu'à ce qu'ils soient au ras du métal ou du plastique.
- Estas tuercas son tuercas de bloqueo central. Están diseñadas para estar apretadas; por lo tanto, serán más difíciles de apretar. Apriételas hasta que estén al ras del metal o plástico.



- Indicates the number of adults required to perform a specific step, e.g., 2, 3, 4, etc.
- Indique le nombre d'adultes requis pour effectuer une étape spécifique, p. ex., 2, 3, 4, etc.
- Indica el número de adultos requeridos para realizar un paso específico, p.ej., 2, 3, 4, etc.







## WARNINGS & NOTICES / AVERTISSEMENTS ET AVIS / ADVERTENCIAS Y AVISOS



### English:

- **Failure to follow these warnings may result in serious injury or property damage and will void warranty.**
- To ensure safety, do not attempt to assemble this product without following the instructions carefully.
- Consult all local building codes to verify if the shed requires a building permit.
- Verify the foundation is completely level before assembling the shed.
- Be aware that plastic pieces can be damaged by overtightening the screws. To avoid damage, we strongly recommend the use of a drill with a low torque setting. A #2 Phillips screwdriver may also be used.
- Three capable adults are required for assembly.
- All who participate in the assembly process should wear safety glasses throughout the assembly.
- If using a ladder during assembly, use extreme caution.
-  In heavy snowfall areas, we recommend removing snow from the roof. Remove the snow from the roof when the depth of snow equals the length of your hand.
- Do not use or store hot objects near the product.
- Proper and complete assembly are essential to reduce the risk of accident or injury.
- When drilling through metal, beware of burrs, shavings and other sharp edges.
- During and after assembly, do not slide or lift the shed by pushing up on the roof. Move the shed by pushing on the corner panels only.
- Failure to anchor the shed may result in property damage and/or personal injury. The last section, *Shed Anchoring*, in this manual shows the hardware you will need to complete the anchoring. You can find the hardware at your local hardware store.
- **Most injuries are caused by misuse and/or not following instructions. Use caution when using this product.**

### Français :

- **Ne pas suivre ces avertissements peut entraîner des blessures graves ou des dommages à la propriété et annulera la garantie.**
- Afin d'assurer la sécurité, ne pas tenter d'assembler ce produit sans suivre attentivement les instructions.
- Consulter tous les codes du bâtiment afin de vérifier si l'abri nécessite un permis de construire.
- Vérifier que la fondation est complètement à niveau avant l'assemblage de l'abri.
- Ne pas oublier que les pièces de plastique peuvent être endommagées en serrant trop les vis. Afin d'éviter les dommages, nous recommandons fortement l'utilisation d'une perceuse à faible couple. Un tournevis cruciforme n° 2 peut aussi être utilisé.
- Trois adultes en bonne condition physique sont nécessaires pour l'assemblage.
- Tout ceux qui participent au processus de l'assemblage doivent porter des lunettes de sécurité tout au long de l'assemblage.
- Si une échelle est utilisée pour l'assemblage, il faut être extrêmement prudent.
- Dans les zones de fortes tombées de neige, il est recommandé de dégager le toit. Enlever la neige du toit quand la profondeur est égale à la longueur de la main.
- Ne pas utiliser ou entreposer des objets très chauds près de ce produit.
-  Un bon assemblage complet est nécessaire pour réduire le risque d'accident ou de blessure.
-  En perçant le métal, faire attention aux bavures, copeaux et autre bords aiguisés.
- Pendant et après l'assemblage, ne pas faire glisser ou soulever l'abri en poussant le toit vers le haut. Déplacer l'abri en poussant les panneaux muraux angulaires seulement.
- Si vous n'ancrez pas votre abri, des dommages à la propriété et/ou des blessures peuvent en résulter. La dernière section, *Ancrage de l'abri*, de ce manuel indique les matériaux nécessaires pour l'ancrage. Les matériaux se trouvent dans la quincaillerie locale.
- **La majorité des blessures sont causées par une mauvaise utilisation et/ou le non suivi des instructions. Être prudent en utilisant ce produit.**

### Español:

- **No seguir estas advertencias puede resultar en lesiones graves o daños a la propiedad y anulará la garantía.**
- A fin de garantizar la seguridad, no intentar ensamblar este producto sin seguir cuidadosamente las instrucciones.
- Consultar todos los códigos de construcción locales para verificar si la caseta requiere un permiso de construcción.
- Verificar que el concreto esté nivelado completamente antes de ensamblar la caseta.
- Tener en cuenta que las piezas de plástico pueden dañarse si los tornillos se aprietan de más. A fin de evitar daños, lo exhortamos a que use un taladro con función de torque bajo. También puede usarse un desatornillador Phillips no. 2.
- Se necesitan tres adultos para el ensamble.
- Todos los que participen en el proceso de ensamble debe usar anteojos de seguridad durante todo el ensamble.
- Si se usa una escalera durante el ensamblado, es preciso tener cuidado.
- En áreas de nevadas fuertes, recomendamos retirar la nieve del techo. Quitar la nieve del tejado cuando la profundidad de ella es igual a la longitud de la mano.
- No usar ni guardar objetos calientes cerca del producto.
-  El ensamblaje correcto y completo son esenciales para reducir el riesgo de accidente o lesión.
-  Al perforar metal, tenga cuidado las rebabas, virutas y otros bordes afilados.
- Durante y después del ensamblaje, no deslizar ni levantar la caseta para empujar en el tejado. Mover la caseta para empujar los paneles murales angulares solamente.
- No anclar la caseta puede resultar en daños a la propiedad y/o en lesiones personales. La última sección, *Anclaje de la caseta*, en este manual muestra el herraje necesaria para terminar el anclaje. Se encuentra el herraje en la ferretería local.
- **La mayoría de las lesiones suceden a causa del mal uso y/o por no seguir las instrucciones. Tener precaución al usar este producto.**

## PLATFORM CONSTRUCTION (MATERIALS NOT INCLUDED) / CONSTRUCTION DE LA PLATE-FORME (LES PIÈCES NE SONT PAS INCLUSES) / CONSTRUCCIÓN DE LA PLATAFORMA (LOS MATERIALES NO SON INCLUIDOS)



• You must provide a platform on which to assemble your shed. Proper building permit documentation may be required in your neighborhood. Consult all local building codes prior to assembling the shed. Before beginning assembly, you must pour or construct a platform. There are two types:

- Concrete
- Wood Frame

Select the type, but know the surface must be leveled before installation. If the surface is not properly leveled, the shed will not assemble correctly. Proper surface leveling will save you time in the long run, so please do not ignore this step. **We recommend a Concrete platform. It will be the most durable and long-lasting choice. The platform you choose must be built above ground in order to avoid water pooling inside the shed. All lumber must be rated for outdoor use!**



• Il faut construire une plate-forme sur laquelle vous devez assembler votre abri. Il est possible que votre quartier exige une documentation visant les permis de construire. Consulter tous les codes du bâtiment locaux, ainsi que les décrets des villes et comtés, pour vérifier que la construction de l'abri extérieur n'exige pas un permis de construire. Avant de commencer le montage, il faut couler ou construire une plate-forme. Il y a deux styles :

- Béton
- Cadre à bois

Sélectionner le style, mais savoir que la surface d'installation doit être de niveau. Si la surface n'est pas correctement de niveau, l'assemblage de l'abri ne se fera pas correctement. On gagnera du temps sur le long terme grâce à une surface bien de niveau. Ne pas négliger cette étape. **Nous recommandons une plate-forme en béton. Ce choix sera le plus durable. La plate-forme choisie doit être construite au-dessus du sol afin d'éviter l'accumulation d'eau à l'intérieur de l'abri. Tous le bois d'oeuvre doit être approuvé pour l'usage à l'extérieur !**



• Es preciso construir una plataforma sobre la cual usted debe ensamblar su caseta. Puede suceder que en el vecindario se requiera la documentación apropiada de un permiso de construcción. Consultar todos los códigos locales de construcción y los reglamentos de la ciudad y el municipio para asegurarse de que la construcción de la caseta no requiere un permiso de construcción. Antes de comenzar el ensamble, es necesario verter o construir una plataforma. Hay dos clases:

- Concreto
- Armazón de madera

Seleccionar la clase, mas saber que la superficie debe estar nivelada antes de comenzar el ensamble. Si la superficie no está nivelada de manera adecuada, la caseta no podrá ensamblarse correctamente. La nivelación de la superficie ahorrará tiempo de trabajo, por lo tanto, no ignorar este paso. **Recomendamos una plataforma hecho de concreto. Será la elección más perdurable. La plataforma debe ser construida arriba del suelo para evitar el aflujo de agua dentro de la caseta. ¡Toda la madera debe estar clasificada para el uso externo!**

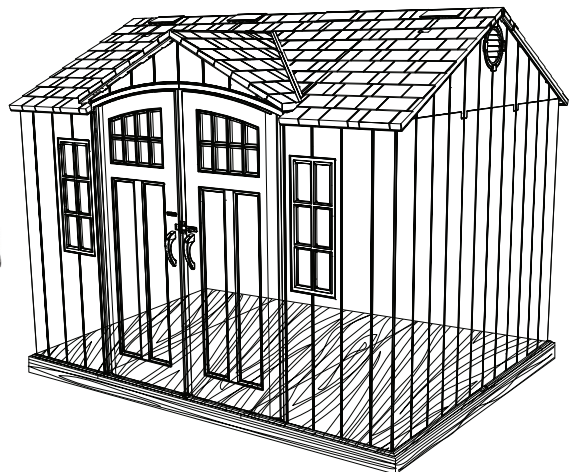
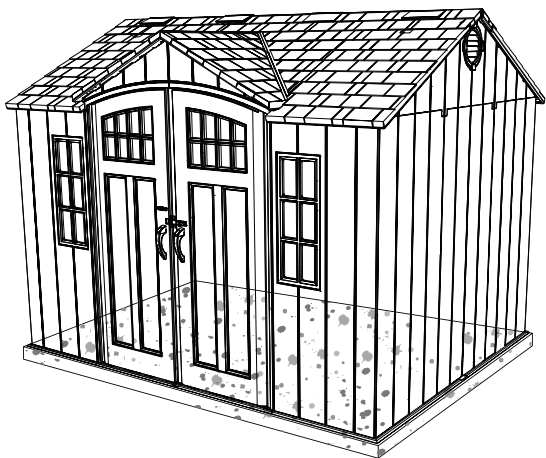

## ► SECTION 1 (CONTINUED) / SECTION 1 (SUITE) / SECCIÓN 1 (CONTINUACIÓN)

CONCRETE REQUIRED / BÉTON REQUIS / CONCRETO REQUERIDO



1 yd<sup>3</sup> (0,77 m<sup>3</sup>)

# 1.1

### CONCRETE PLATFORM / PLATE-FORME EN BÉTON / PLATAFORMA DE CONCRETO

- The concrete should be approximately 4 in (≈10,2 cm) thick. The actual dimensions of the shed, at its widest and longest points, are 95.7" x 119.6" (≈243 cm x 304 cm). Ensure you select a site that will accommodate these measurements. **The floor dimensions are a bit smaller than those of the roof; therefore, you will need to build a level platform of, at least, 94" x 118" (≈238,8 cm x 299,7 cm). These are the measurements of the platform—not the floor.**
- Le béton doit être un épaisseur de ≈10,2 cm (4 po). Les dimensions réelles de l'abri, aux points les plus large et long, sont ≈243 cm x 304 cm (95,7 po x 119,6 po). Veiller à sélectionner un site qui accommodera ces dimensions. **Les dimensions du plancher de votre abri sont plus petites que le toit; ensuite, il faut créer une surface nivelée d'au moins ≈238,8 cm x 299,7 cm (94 po x 118 po). Ces mesures sont de la plate-forme — non le plancher.**
- El concreto debe tener, por lo menos, ≈10,2 cm (4 in) de espesor. Las dimensiones reales de la caseta, a sus puntos más ancho y largo, son ≈243 cm x 304 cm (95,7 in x 119,6 in). Asegurarse de seleccionar un sitio que acomodará estas medidas. **Las dimensiones del piso de la caseta son más pequeñas que el tejado; por lo tanto, se necesita crear una superficie nivelada mínimo de ≈238,8 cm 299,7 cm (94 in x 118 in). Estas medidas son las de la plataforma, no el piso.**

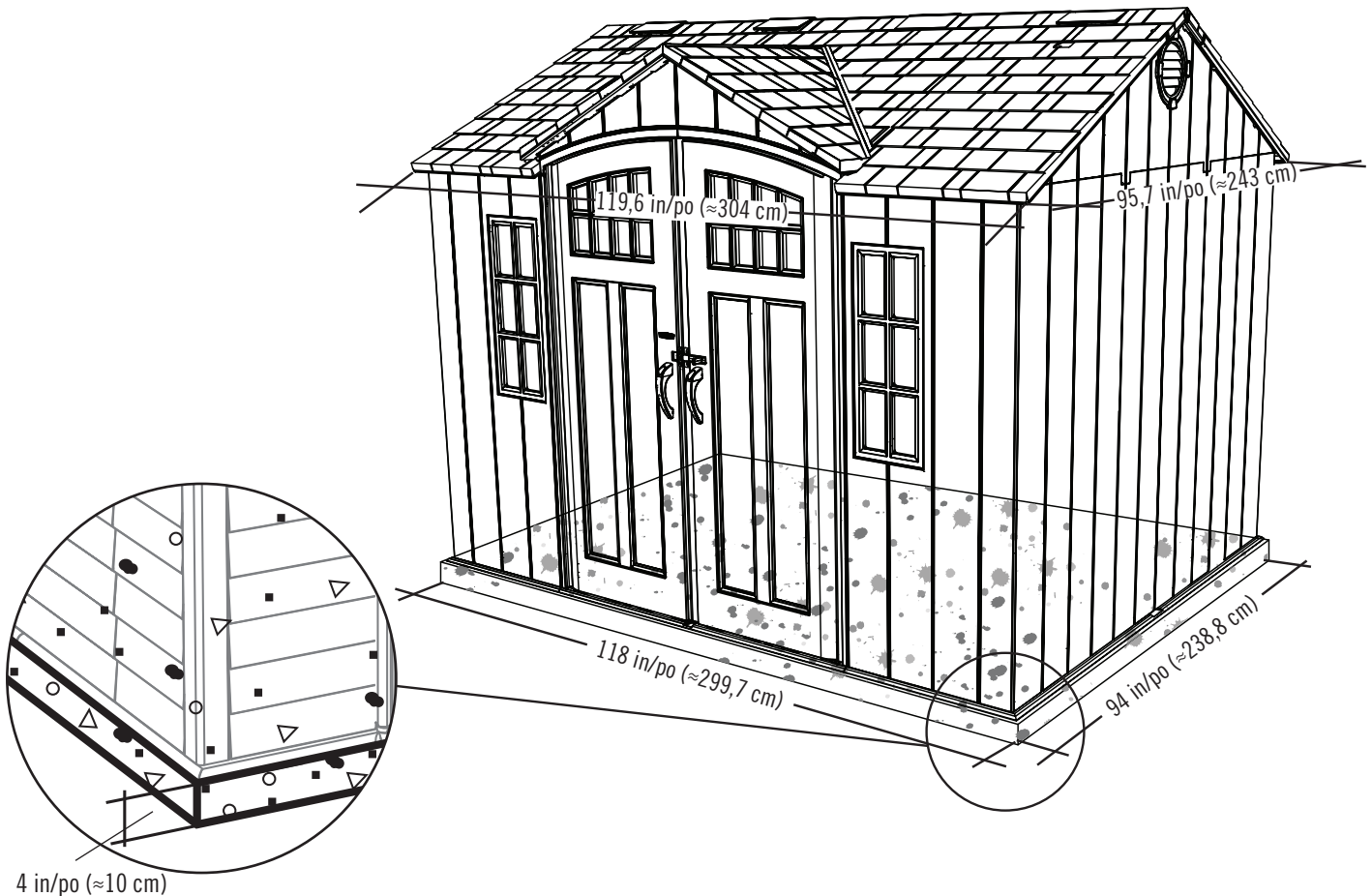

4 in/po (≈10 cm)



## ► SECTION 1 (CONTINUED) / SECTION 1 (SUITE) / SECCIÓN 1 (CONTINUACIÓN)

WOOD REQUIRED / BOIS REQUIS / MADERA REQUERIDA

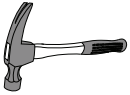

### 1.2

#### WOOD PLATFORM / PLATE-FORME EN BOIS / PLATAFORMA DE MADERA

- **All lumber must be rated for outdoor use!** The actual dimensions of the shed, at its widest and longest points, are 95.7" x 119.6" ( $\approx 243$  cm x 304 cm). Ensure you select a site that will accommodate these measurements. **The floor dimensions are a bit smaller than those of the roof; therefore, you will need to build a level platform of, at least, 94" x 118" ( $\approx 238.8$  cm x 299.7 cm).** These are the measurements of the platform—not the floor.
- **Tous le bois d'oeuvre doit être approuvé pour l'usage à l'extérieur !** Les dimensions réelles de l'abri, aux points les plus large et long, sont  $\approx 243$  cm x 304 cm (95.7 po x 119.6 po). Veiller à sélectionner un site qui accommodera ces dimensions. **Les dimensions du plancher de votre abri sont plus petites que le toit; ensuite, il faut créer une surface nivelée d'au moins  $\approx 238,8$  cm x 299,7 cm (94 po x 118 po).** Ces mesures sont de la plate-forme — non le plancher.
- **¡Toda la madera debe estar clasificada para el uso externo!** Las dimensiones reales de la caseta, a sus puntos más ancho y largo, son  $\approx 243$  cm x 304 cm (95.7 in x 119.6 in). Asegúrese de seleccionar un sitio que acomodará estas medidas. **Las dimensiones del piso de la caseta son más pequeñas que el tejado; por lo tanto, se necesita crear una superficie nivelada mínimo de  $\approx 238,8$  cm 299,7 cm (94 in x 118 in).** Estas medidas son las de la plataforma, no el piso.

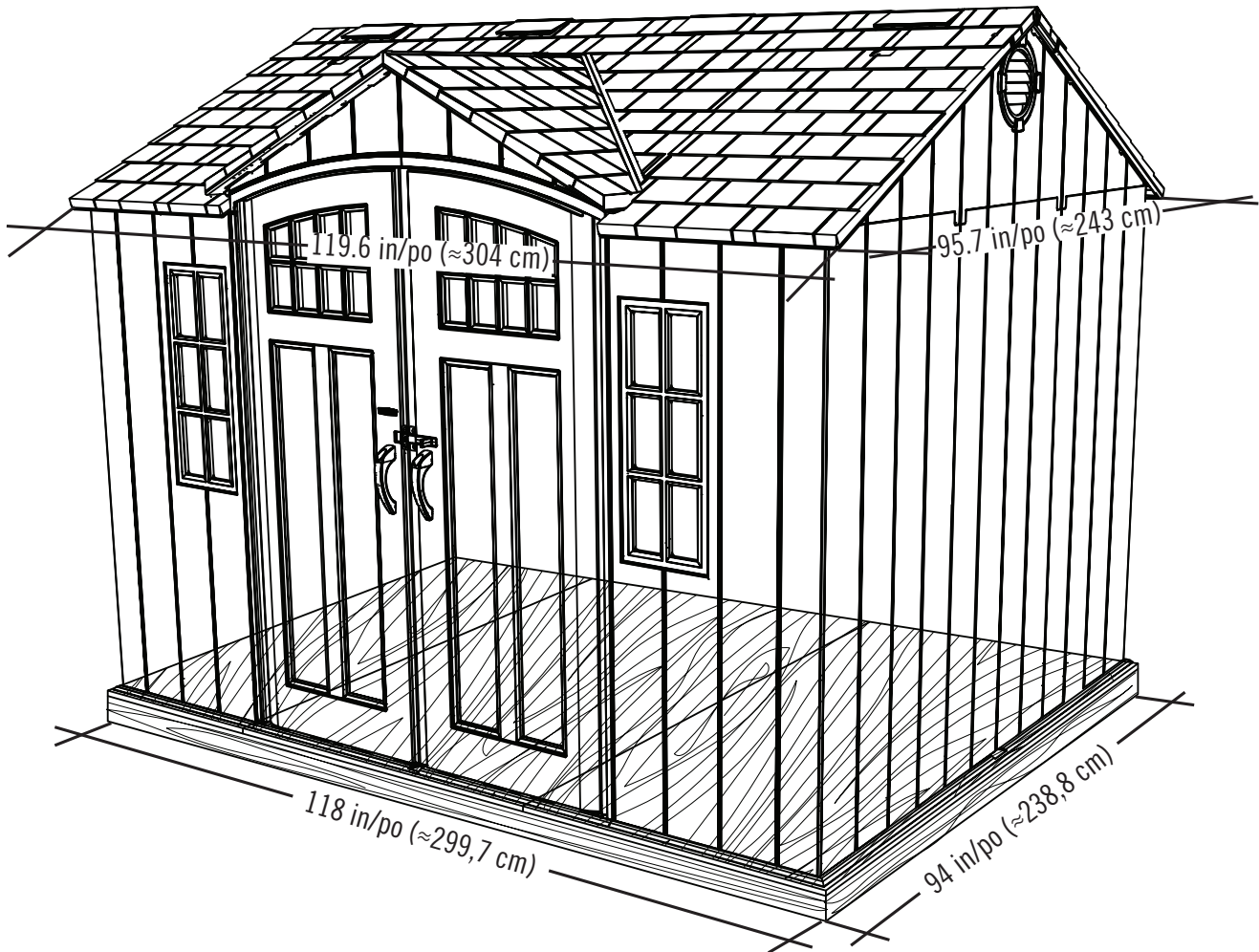



## ► SECTION 1 (CONTINUED) / SECTION 1 (SUITE) / SECCIÓN 1 (CONTINUACIÓN)

TOOLS AND PARTS REQUIRED / OUTILS ET PIÈCES REQUIS / INSTRUMENTAL Y PIEZAS REQUERIDOS

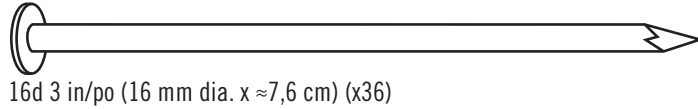
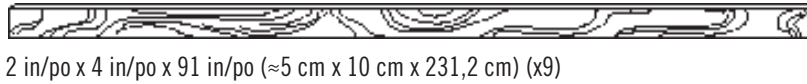
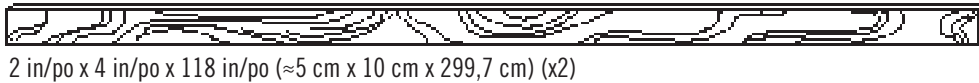
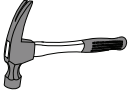

### 1.2.1

- Ensure all lumber is treated and approved for outdoor use. Build frame to 94" x 118" (≈238,8 cm x 299,7 cm) (**outside dimensions**).
- Vérifier que votre bois d'œuvre a été traité et approuvé pour l'utilisation à l'extérieur. Construire un cadre de ≈238,8 cm x 299,7 cm (94 po x 118 po) (**dimensions extérieures**).
- Asegurar que use madera tratada y aprobada para el uso externo. Construir el armazón a ≈238,8 cm x 299,7 cm (94 in x 118 in) (**dimensiones exteriores**).

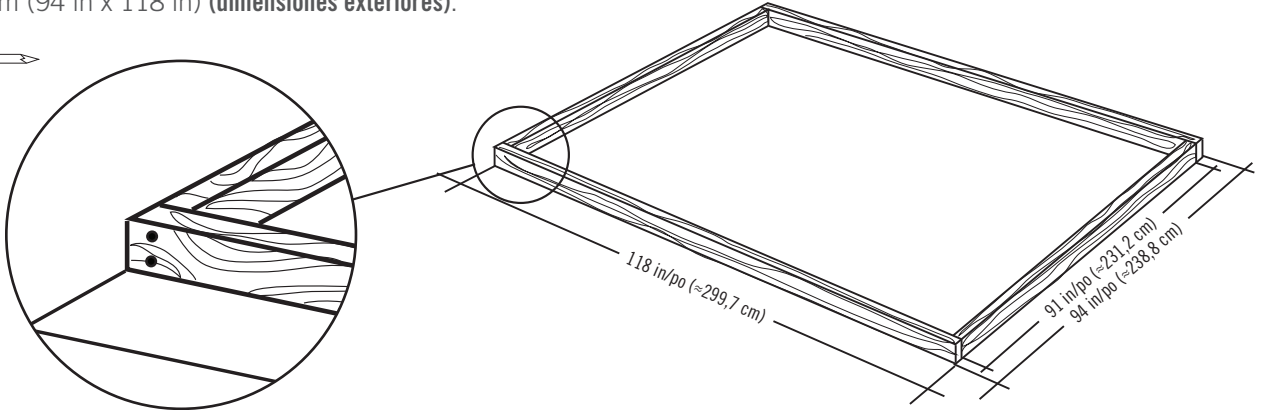
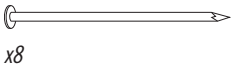

### 1.2.2

- To ensure studs are in the correct location for nailing plywood in the next step, start measuring from the corner 16" (≈40,6 cm), and then measure from center to center.
- Pour être sûr d'avoir assez de montant pour clouer le contreplaqué dans le prochaine étape, commencer à mesurer à partir de cette montant ≈40,6 cm (16 po) vers le centre du deuxième montant. Ensuite, mesurer de centre à centre pour les montants restants.
- Para asegurarse que los montantes están en las ubicaciones correctas para el contrachapado en el paso siguiente, comenzar a medir desde el borde del montante hasta el centro del próximo montante ≈40,6 cm (16 in). Luego, tomar la medida de centro a centro en los montantes restantes.

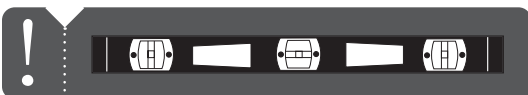
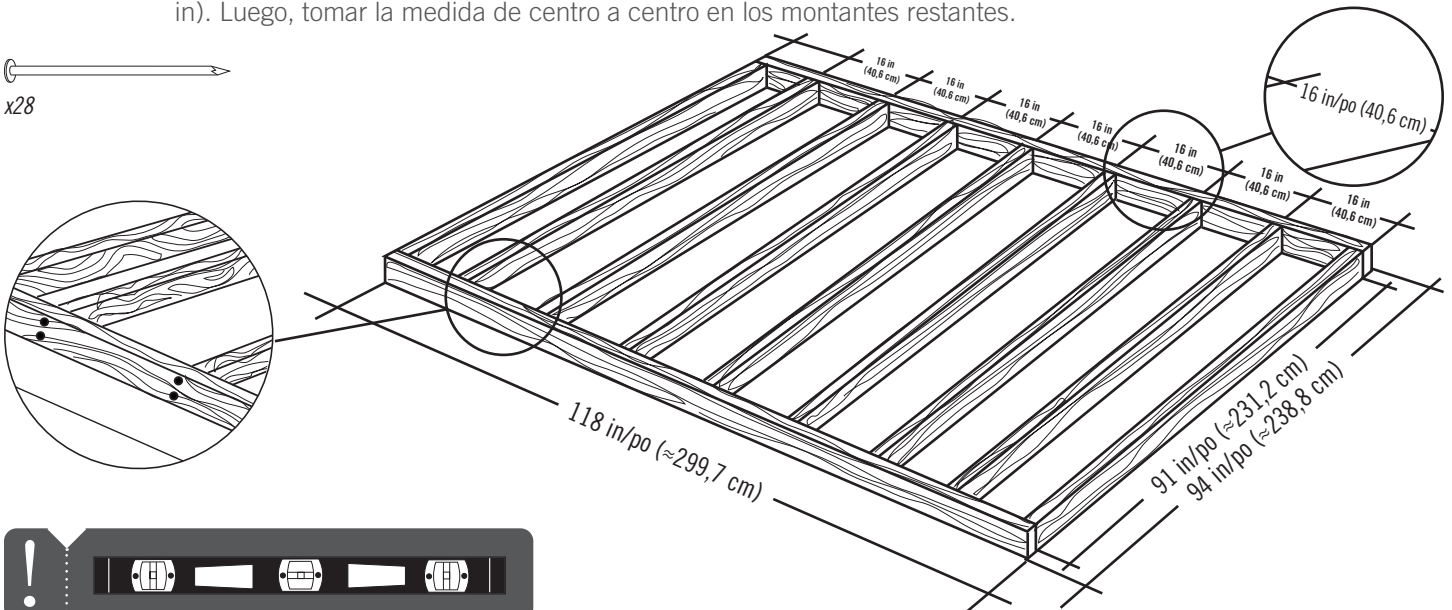
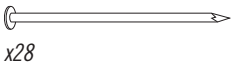

## ► SECTION 1 (CONTINUED) / SECTION 1 (SUITE) / SECCIÓN 1 (CONTINUACIÓN)

TOOLS AND PARTS REQUIRED / OUTILS ET PIÈCES REQUIS / INSTRUMENTAL Y PIEZAS REQUERIDOS

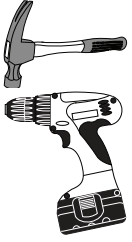

48 in/po x 94 in/po x 0.75 in/po  
(≈121,9 cm x 238,8 cm x 19,1 mm) (x2)



22 in/po x 94 in/po x 0.75 in/po  
(≈55,9 cm x 238,8 cm x 19,1 mm) (x1)



8 mm dia. 1 1/2 in/po (8d ≈3,81 cm) (x66)

### 1.2.3

- Square the frame measuring from corner to corner.
- Carrer le cadre en mesurant d'angle à angle.
- Cuadrar el armazón midiendo de esquina a esquina.

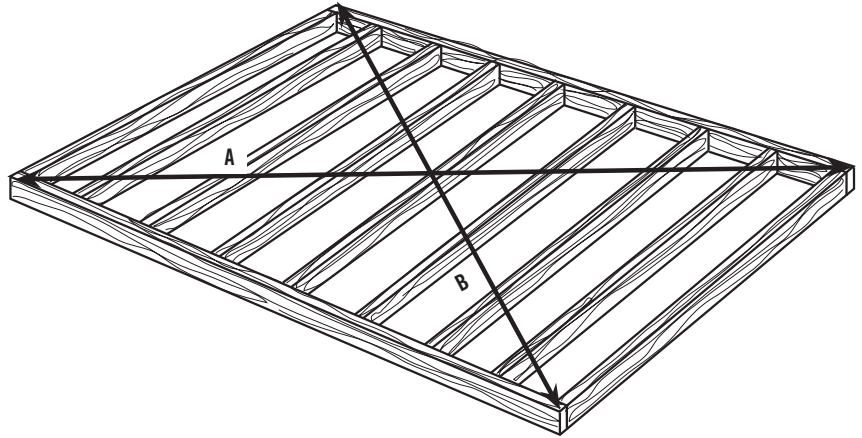

! A = B

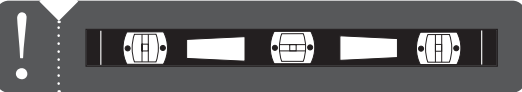

### 1.2.4

- Using nails, fasten the plywood to the frame. Then, drill holes for drainage.
- En utilisant des clous, fixer bien le contreplaqué au cadre. Ensuite, percer des trous de drainage.
- Usando unos clavos, fijar el contrachapado al armazón. Entonces, taladrar agujeros para el drenaje.

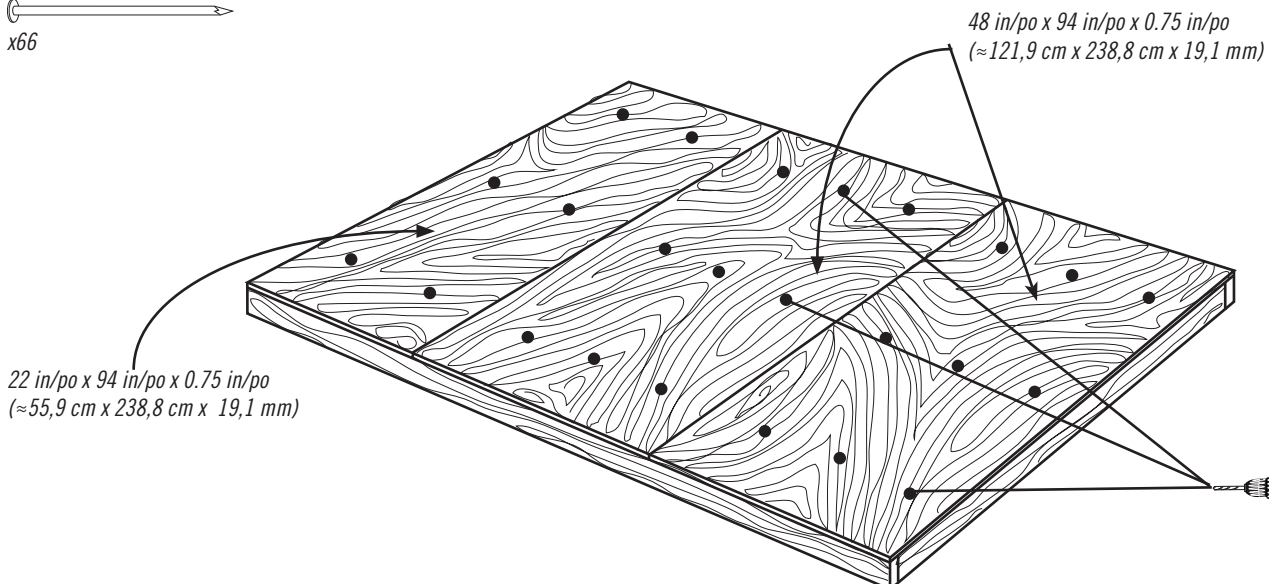
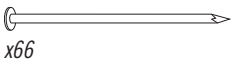

- Drainage Holes
- Trous de drainage
- Agujeros para canalización

**x24!**

# 2

## TRUSS ASSEMBLY / ASSEMBLAGE DES FERMES / ENSAMBLE DE LAS CERCHAS



### HARDWARE REQUIRED / QUINCAILLERIE REQUISE / HERRAJE REQUERIDO

Hardware Bag / Sac quincaillerie / Bolsa de herraje

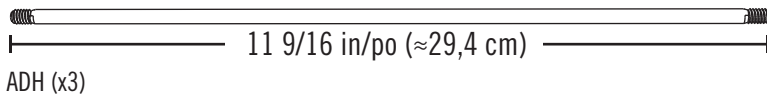
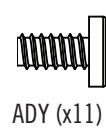
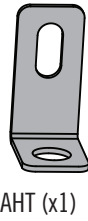
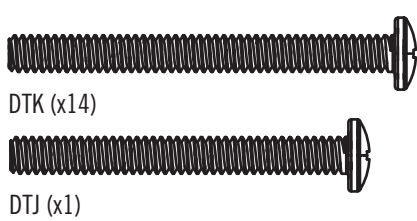

### PARTS REQUIRED / PIÈCES REQUISES / PIEZAS REQUERIDAS

Metal Parts / Pièces en métal / Piezas de metal

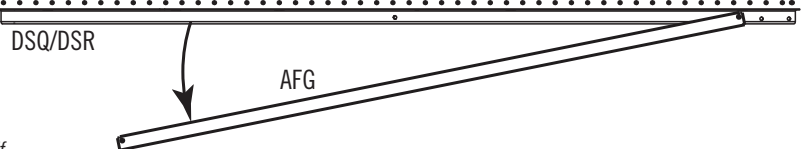
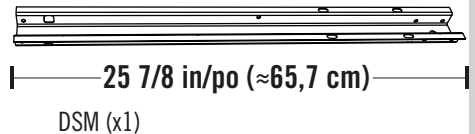
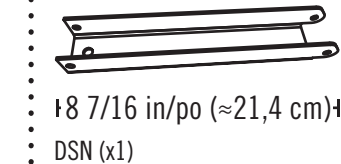
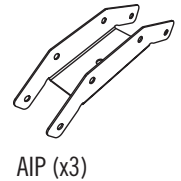
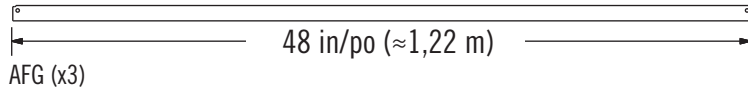
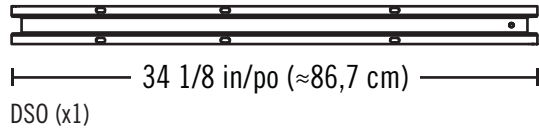
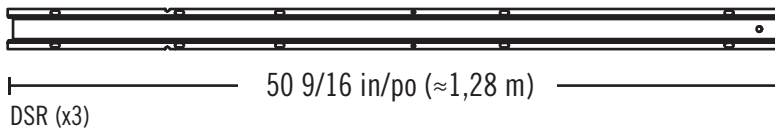
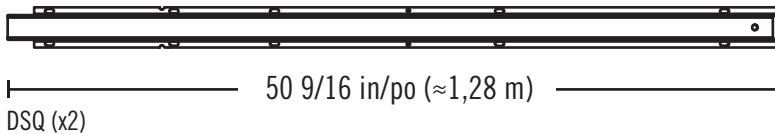
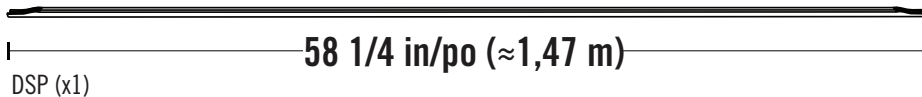

- Sometimes during shipping, the Truss Brace (AFG) slides over the back of the Truss Gutter Channel (DSQ or DSR). The two pieces are the same color. If you think you're missing a Truss Brace, check to see if it is stuck to the back of the Truss Gutter Channel, and separate the two.
- Durant le transport, parfois le support de ferme (AFG) glisse par-dessus l'arrière du canal de ferme (DSQ ou DSR). Les deux pièces sont de même couleur. Si vous pensez que vous n'avez pas de support de ferme, vérifiez s'il y a un support de ferme adhérent à l'arrière du canal de ferme, et séparez les deux.
- Durante el transporte, a veces el soporte de cercha (AFG) deslice sobre el dorso del canalón de cercha (DSQ o DSR). Las dos piezas son de la misma color. Si piensas que le falta un soporte de cercha, verifique si haya un soporte pegado al dorso del canalón de cercha, y separe las dos.



### TOOLS REQUIRED / OUTILS REQUIS / INSTRUMENTAL REQUERIDO



7/16 in/po (≈11 mm) (x2)

3/8 in/po (≈10 mm) (x2)



## ► SECTION 2 (CONTINUED) / SECTION 2 (SUITE) / SECCIÓN 2 (CONTINUACIÓN)

TOOLS AND HARDWARE REQUIRED / OUTILS ET QUINCAILLERIE REQUIS / INSTRUMENTAL Y HERRAJE REQUERIDOS



- If you have trouble with this section, follow the code below to view a how-to video on the assembly for this section.
- En cas d'avoir des problèmes avec cette section, suivre le code en bas pour voir un vidéo sur l'assemblage de cette section.
- En caso de tener problemas con esta sección, seguir el código debajo para ver un video sobre el ensamble en esta sección.

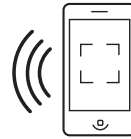

<http://go.lifetime.com/trussassem10x8>



- There are two types of Long Gutter Channels: DSQ and DSR. One end of Channel DSQ is notched. Channel DSR has no notches at either end. This is important to know when assembling the two side trusses; they take one of each. The Center Truss uses the remaining Channel DSR.
- Il y a deux types de canaux de gouttière longs : DSQ et DSR. Une extrémité du canal DSQ est encochée. Le canal DSR n'a pas d'encoches à l'une ou l'autre des extrémités. Il importe de savoir que chaque ferme latérale s'assemble à l'aide de chacun de ces deux canaux. La ferme centrale s'assemble en utilisant le canal DSR restant.
- Hay dos tipos de canaletas largas: DSQ y DSR. Un extremo de la canaleta DSQ ha sido muescado. El canal DSR no tiene muescas en cualquiera de las dos extremos. Es importante entender esto al ensamblar las dos cerchas laterales; se utiliza cada uno de los dos. Se ensambla la cercha central usando el canal DSR restante.

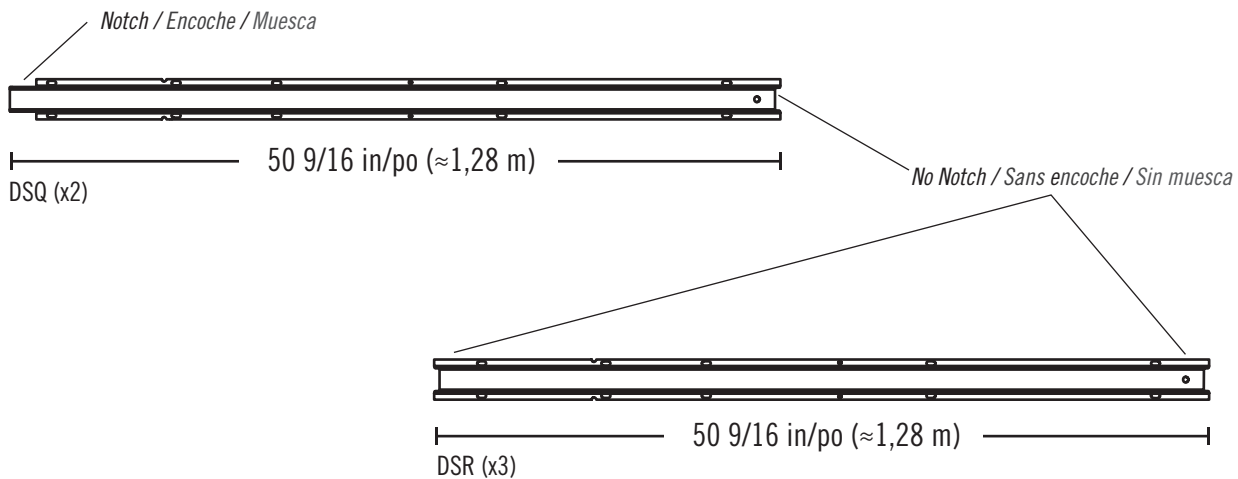

## ► SECTION 2 (CONTINUED) / SECTION 2 (SUITE) / SECCIÓN 2 (CONTINUACIÓN)

TOOLS AND HARDWARE REQUIRED / OUTILS ET QUINCAILLERIE REQUIS / INSTRUMENTAL Y HERRAJE REQUERIDOS



3/8 in/po  
(≈10 mm)



### 2.1

#### SIDE TRUSSES (x2) / FERMES LATÉRILES (x2) / CERCHAS LATERALES (x2)

- Attach a **Connector (AIP)** to the end of two **Truss Gutter Channels (DSQ & DSR)** as shown.
- Attacher un **raccord (AIP)** à l'extrémité des **canaux de gouttière (DSQ et DSR)** comme indiqué.
- Sujetar un **connector (AIP)** a los extremos de los **canalones de la cercha (DSQ y DRS)** como se muestra.

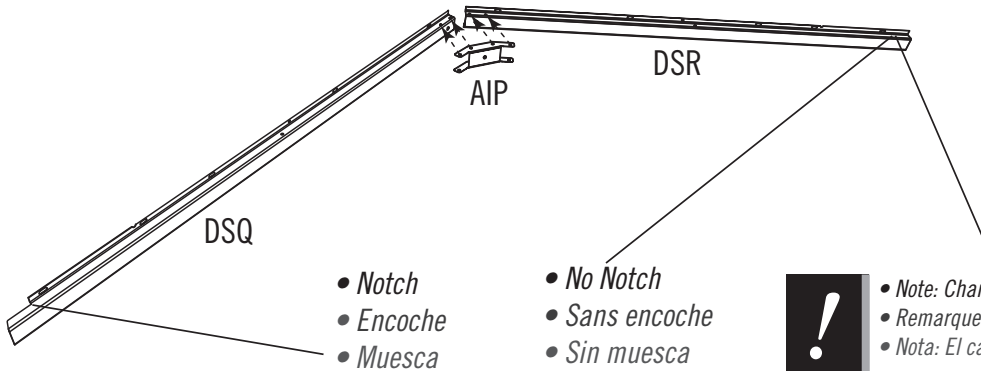

- Note: Channel (DSR) has no notch at the end.
- Remarque : Le canal (DSR) n'a pas d'encoche à l'extrémité.
- Nota: El canalón (DSR) no tiene una muesca al extremo.

### 2.2

- Attach a **Connector (AIP)** to the end of the **Truss Gutter Channels (DSQ & DSR)** as shown.
- Attacher un **raccord (AIP)** à l'extrémité des **canaux de gouttière (DSQ et DSR)** comme indiqué.
- Sujetar un **connector (AIP)** a los extremos de los **canalones de la cercha (DSQ y DSR)** como se muestra.

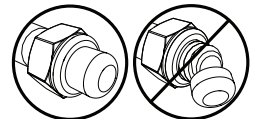
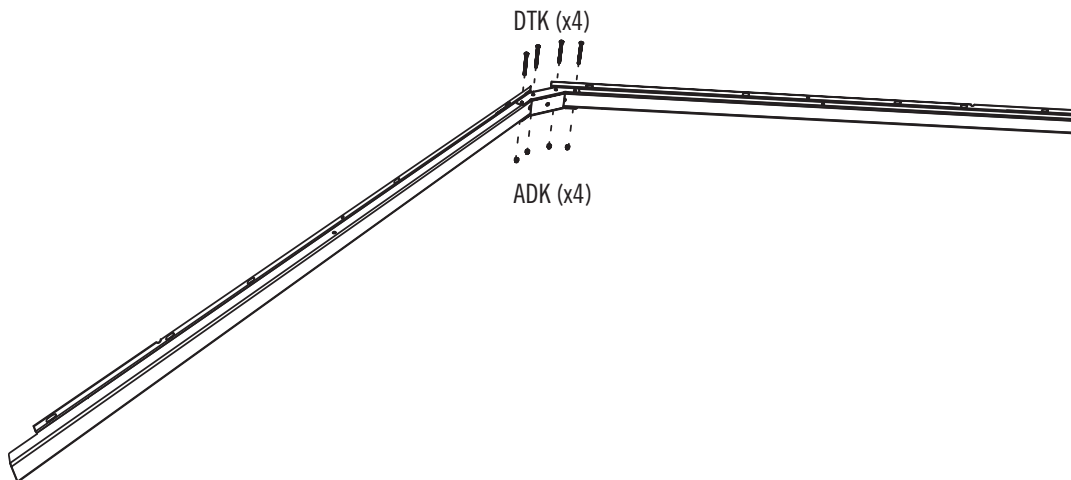

## ► SECTION 2 (CONTINUED) / SECTION 2 (SUITE) / SECCIÓN 2 (CONTINUACIÓN)

TOOLS AND HARDWARE REQUIRED / OUTILS ET QUINCAILLERIE REQUIS / INSTRUMENTAL Y HERRAJE REQUERIDOS



3/8 in/po  
(≈10 mm)

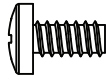

ADY (x8)



ADK (x8)

### 2.3

- Slide a **Truss Brace (AFG)** onto the Truss Gutter Channels as shown.
- Faire glisser un **support de la ferme (AFG)** sur les canaux de gouttière comme indiqué.
- Deslizar un **soporte de la cercha (AFG)** sobre los canalones de la cercha como se muestra.

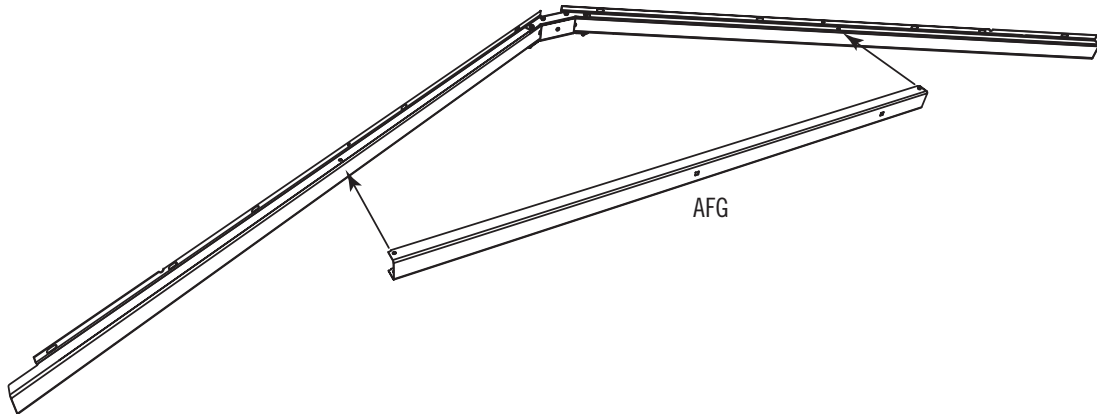

### 2.4

- Attach the Truss Brace using the hardware provided. **Do not overtighten.**
- Attacher le support de la ferme à l'aide de la quincaillerie incluse. **Ne pas serrer excessivement.**
- Sujetar el soporte de la cercha usando el herraje incluido. **No apretar demasiado.**

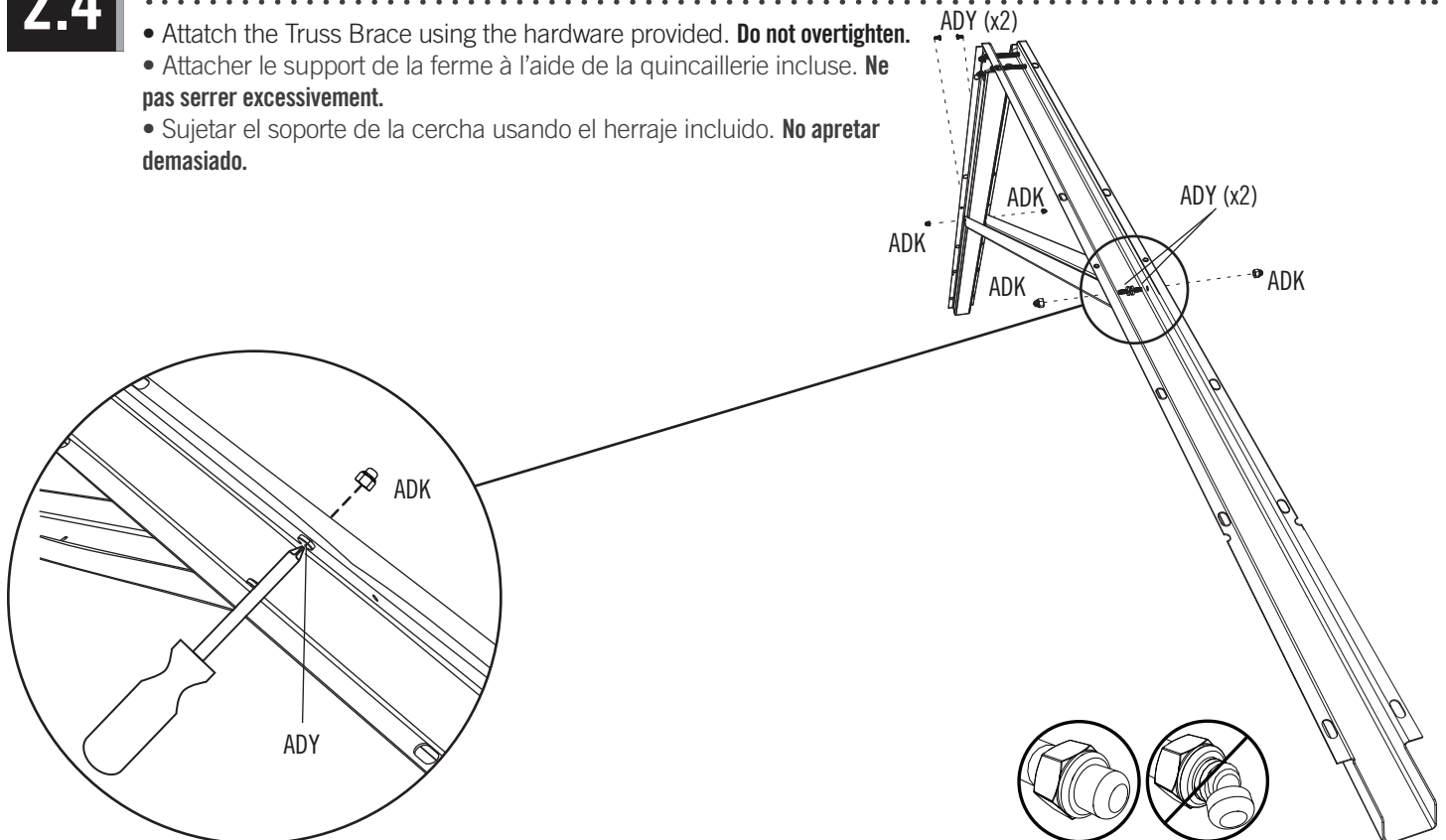

## ► SECTION 2 (CONTINUED) / SECTION 2 (SUITE) / SECCIÓN 2 (CONTINUACIÓN)

TOOLS AND HARDWARE REQUIRED / OUTILS ET QUINCAILLERIE REQUIS / INSTRUMENTAL Y HERRAJE REQUERIDOS



7/16 in/po (x2)  
(≈11 mm) (x2)



ADJ (x4)

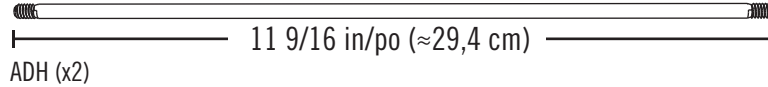

11 9/16 in/po (≈29,4 cm)

ADH (x2)

### 2.5

- Slide a **Truss Rod (ADH)** through the holes in the Brace and Connector. Secure with two **Cap Nuts (ADJ)**.
- Faire glisser une **tige (ADH)** à travers les trous dans le support et le raccord. Bien l'attacher à l'aide de deux **écrous borgnes (ADJ)**.
- Deslizar una **varilla (ADH)** a través de los agujeros en el soporte y el conector. Sujectarla con dos **tuercas ciegas (ADJ)**.

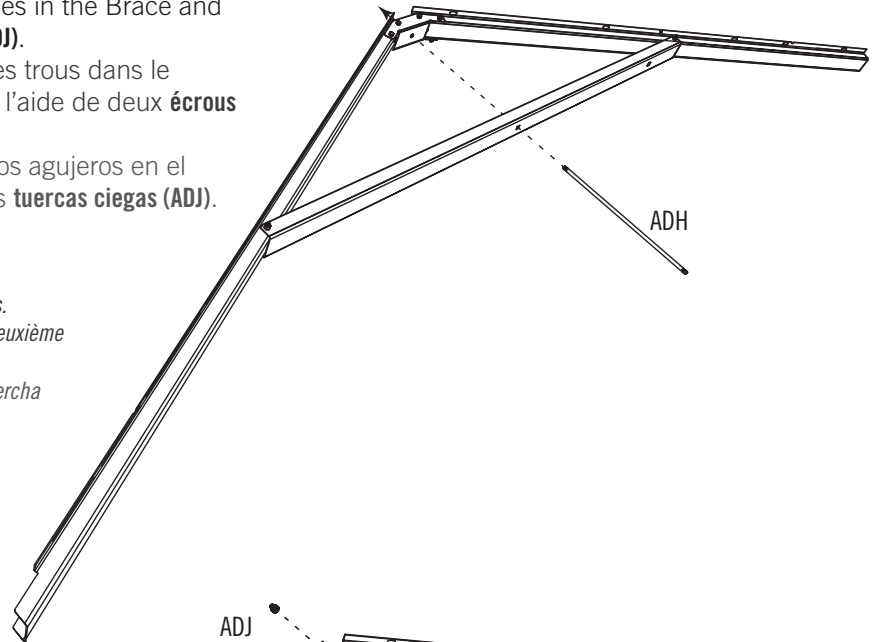

- **Note:** Repeat the previous steps for a second Side Truss.
- **Remarque :** Répéter les étapes précédentes pour une deuxième ferme latérale.
- **Nota:** Repetir los pasos anteriores para una segunda cercha lateral.

ADJ

ADJ

- **Note:** This notched end will face the front of the shed.
- **Remarque :** Cette extrémité encochée fera face à la partie avant de l'abri.
- **Nota:** Este extremo muescado dará a la parte delantera de la caseta.

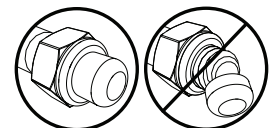

## ► SECTION 2 (CONTINUED) / SECTION 2 (SUITE) / SECCIÓN 2 (CONTINUACIÓN)

TOOLS AND HARDWARE REQUIRED / OUTILS ET QUINCAILLERIE REQUIS / INSTRUMENTAL Y HERRAJE REQUERIDOS



3/8 in/po (x2)  
(≈10 mm) (x2)



DTK (x4)



ADK (x4)

### 2.6

CENTER TRUSS (x1) / CERCHA CENTRAL (x1) / FERME CENTRALE (x1)

- Attach a **Connector (AIP)** to the end of two **Truss Gutter Channels (DSM & DSR)** as shown.
- Attacher un **raccord (AIP)** à l'extrémité des **canaux de gouttière (DSM et DSR)** comme indiqué.
- Sujeter un **connector (AIP)** a los extremos de los **canalones de la cercha (DSM y DRS)** como se muestra.

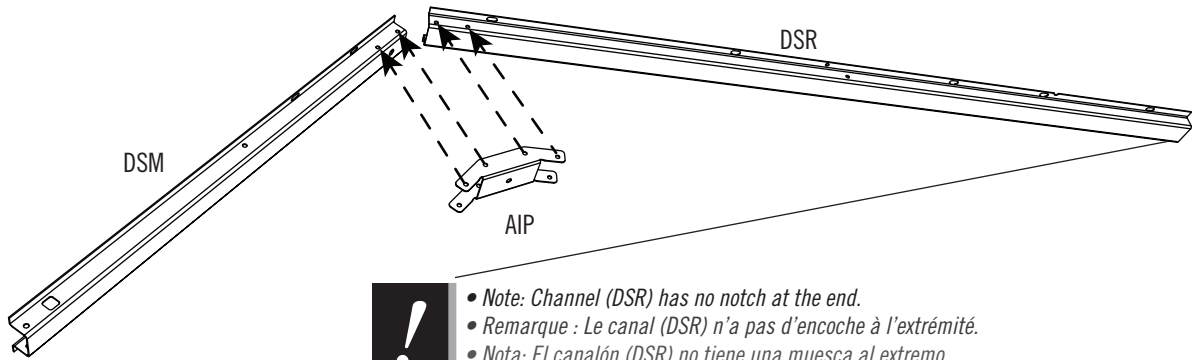

- *Note: Channel (DSR) has no notch at the end.*
- *Remarque : Le canal (DSR) n'a pas d'encoche à l'extrémité.*
- *Nota: El canalón (DSR) no tiene una muesca al extremo.*

### 2.7

- Attach a **Connector (AIP)** to the end of two **Truss Gutter Channels (DSQ)** using the hardware provided. **Do not overtighten the Cap Nuts (ADK).**
- Attacher un **raccord (AIP)** à l'extrémité des **canaux de gouttière (DSQ)** à l'aide de la quincaillerie incluse. **Ne pas trop serrer les écrous borgnes (ADK).**
- Sujeter un **connector (AIP)** a los extremos de los **canalones de la cercha (DSQ)** usando el herraje incluido. **No apretar demasiado las tuercas ciegas (ADK).**

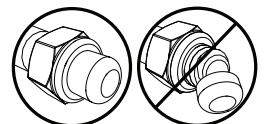
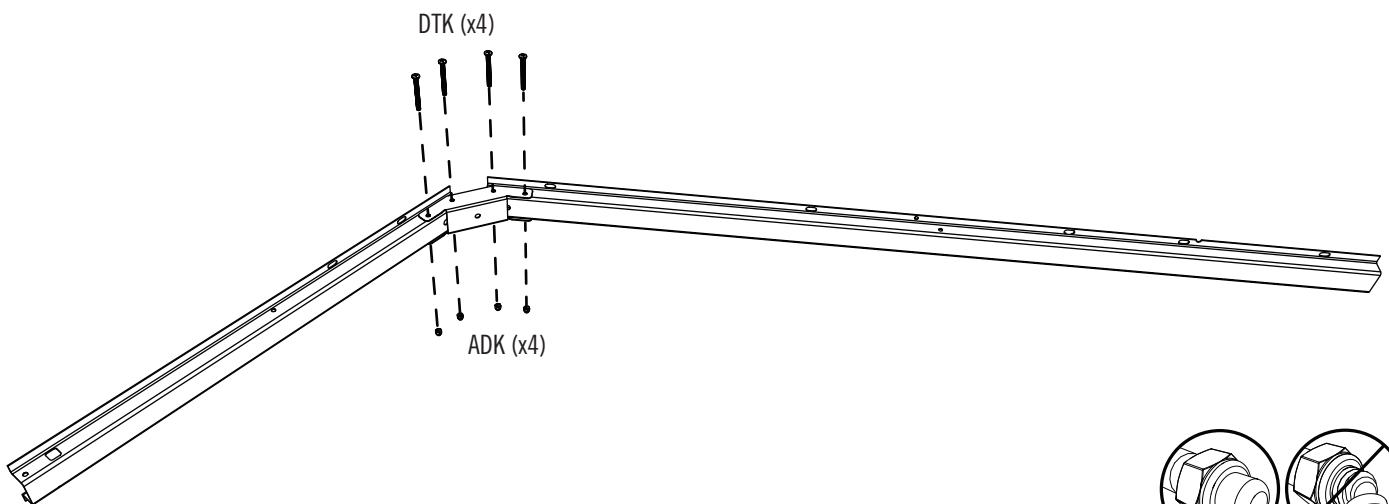

## ► SECTION 2 (CONTINUED) / SECTION 2 (SUITE) / SECCIÓN 2 (CONTINUACIÓN)

TOOLS AND HARDWARE REQUIRED / OUTILS ET QUINCAILLERIE REQUIS / INSTRUMENTAL Y HERRAJE REQUERIDOS



3/8 in/po  
(≈10 mm)

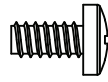

ADY (x2)



ADK (x2)

### 2.8

- Slide a **Truss Brace (AFG)** onto the Truss Gutter Channels as shown.
- Faire glisser un **support de la ferme (AFG)** sur les canaux de gouttière comme indiqué.
- Deslice un **soporte de la cercha (AFG)** sobre los canalones de la cercha como se muestra.

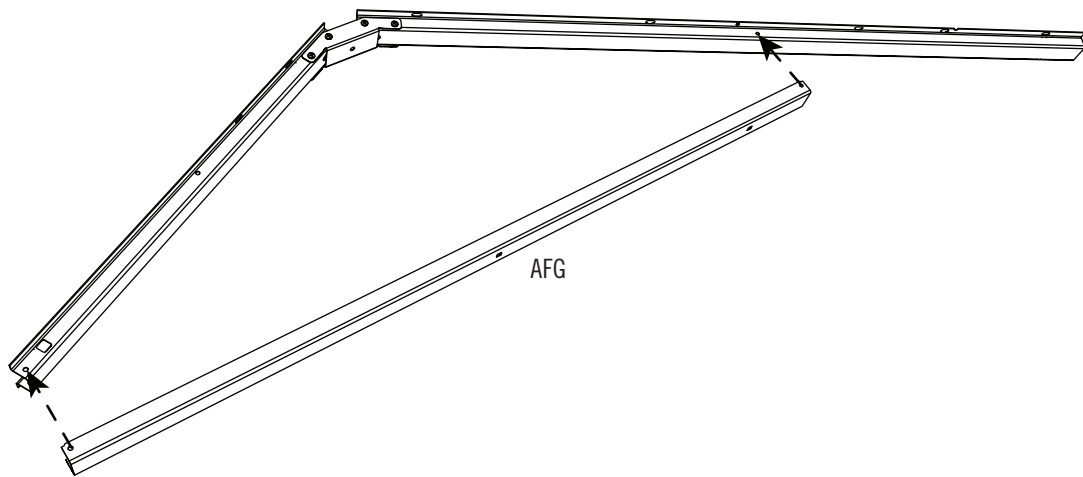

### 2.9

- Attach the Truss Brace using the hardware provided. **Do not overtighten.**
- Attacher le support de la ferme à l'aide de la quincaillerie incluse. **Ne pas serrer excessivement.**
- Sujetar el soporte de la cercha usando el herraje incluido. **No apretar demasiado.**

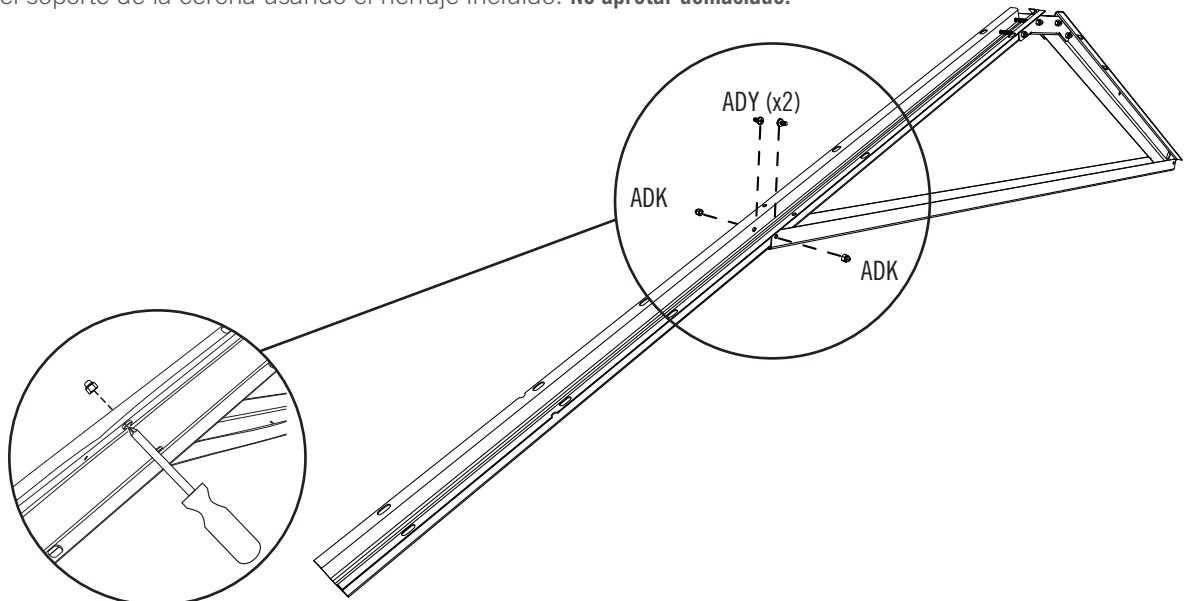

## ► SECTION 2 (CONTINUED) / SECTION 2 (SUITE) / SECCIÓN 2 (CONTINUACIÓN)

TOOLS AND HARDWARE REQUIRED / OUTILS ET QUINCAILLERIE REQUIS / INSTRUMENTAL Y HERRAJE REQUERIDOS



3/8 in/po  
(≈10 mm)



DTK (x2)



ADK (x1)



DTJ (x1)



CXK (x2)

### 2.10

- Attach the **Vertical Truss Brace (DSN)** to the Truss. Only finger tighten this **Nut (ADK)** for now.
- Attacher le **support vertical (DSN)** à la ferme. Serrer l'**écrou (ADK)** à la main en ce moment.
- Fijar el **soporte vertical (DSN)** a la cercha. Apretar la **tuerca (ADK)** a mano por el momento.

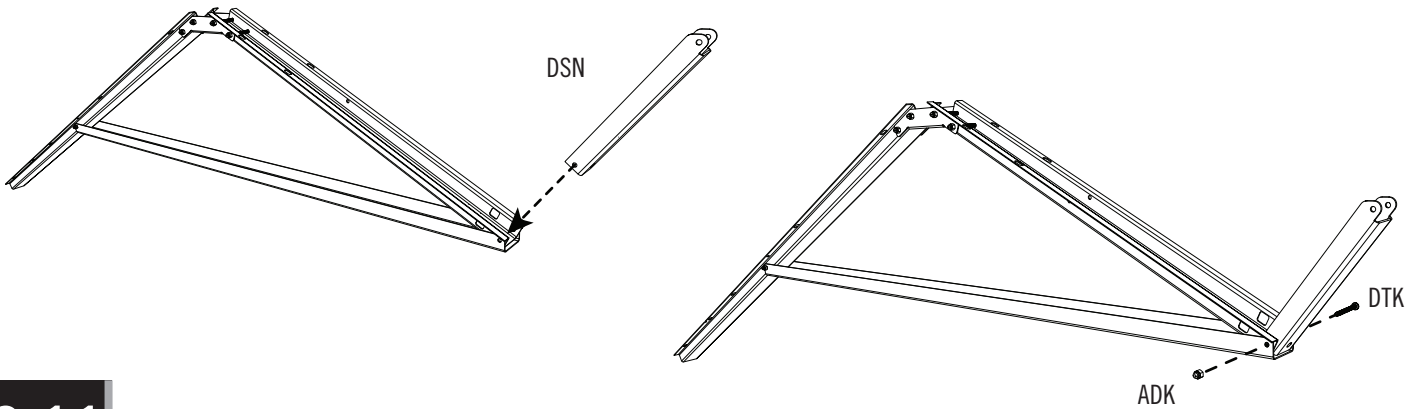

### 2.11

- Secure the **Horizontal Truss Brace (DSO)** to the Truss with the hardware shown. **Now, tighten the Nut from Step 2.10.**
- Attacher le **support horizontal (DSO)** à la ferme à l'aide de la quincaillerie incluse. **Maintenant, serrer l'écrou de l'étape 2.10.**
- Sujetar el **soporte horizontal (DSO)** a la cercha usando el herraje indicado. **Ahora, apretar la tuerca del paso 2.10.**

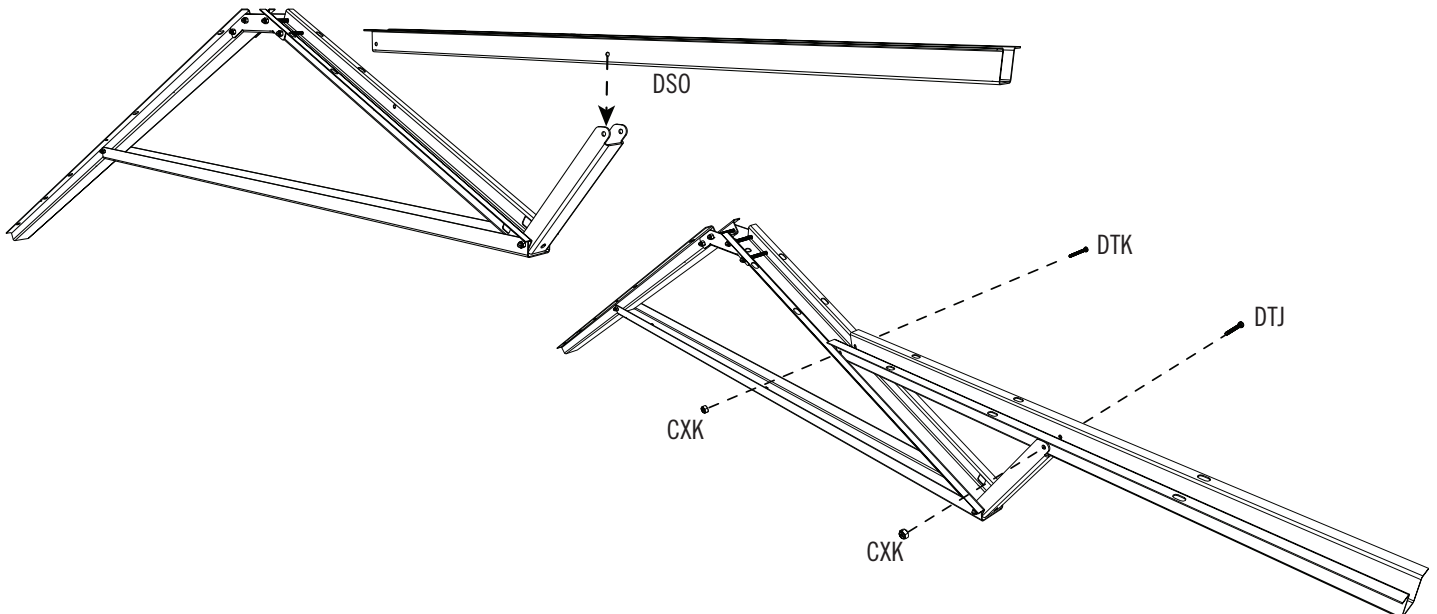



## ► SECTION 2 (CONTINUED) / SECTION 2 (SUITE) / SECCIÓN 2 (CONTINUACIÓN)

TOOLS AND HARDWARE REQUIRED / OUTILS ET QUINCAILLERIE REQUIS / INSTRUMENTAL Y HERRAJE REQUERIDOS

  
7/16 in/po (x2)  
(≈11 mm) (x2)

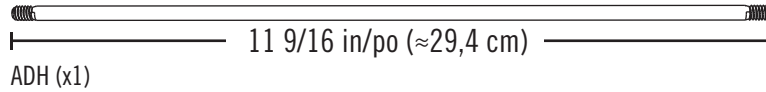
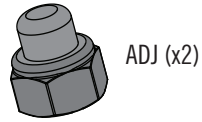

### 2.12

- Slide a **Truss Rod (ADH)** through the holes in the Brace and Connector. Secure with two **Cap Nuts (ADJ)**.
- Faire glisser une **tige (ADH)** à travers les trous dans le support et le raccord. Bien l'attacher bien à l'aide de deux **écrous borgnes (ADJ)**.
- Deslizar una **varilla (ADH)** a través de los agujeros en el soporte y el conector. Sujetarla con dos **tuercas ciegas (ADJ)**.

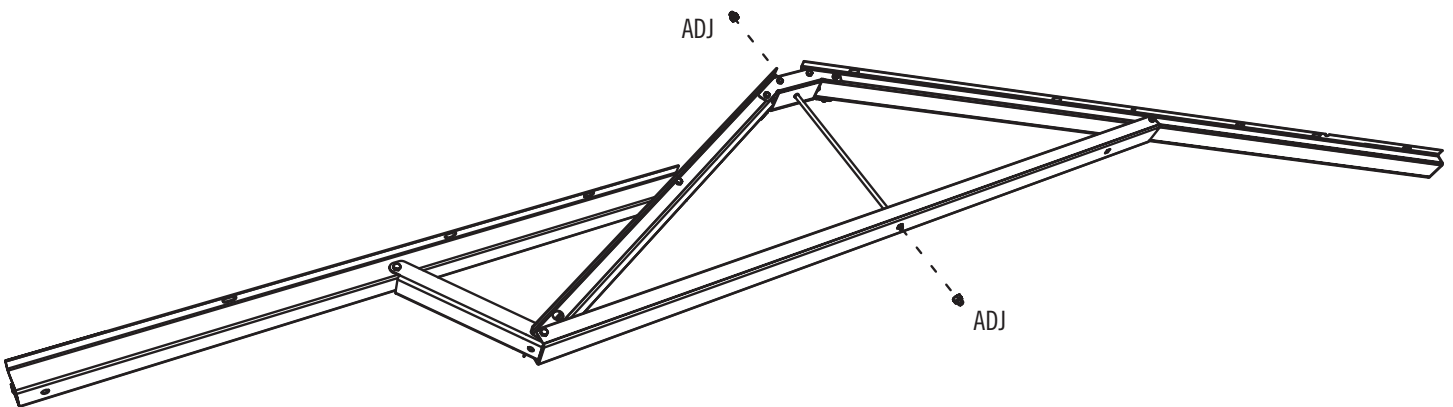
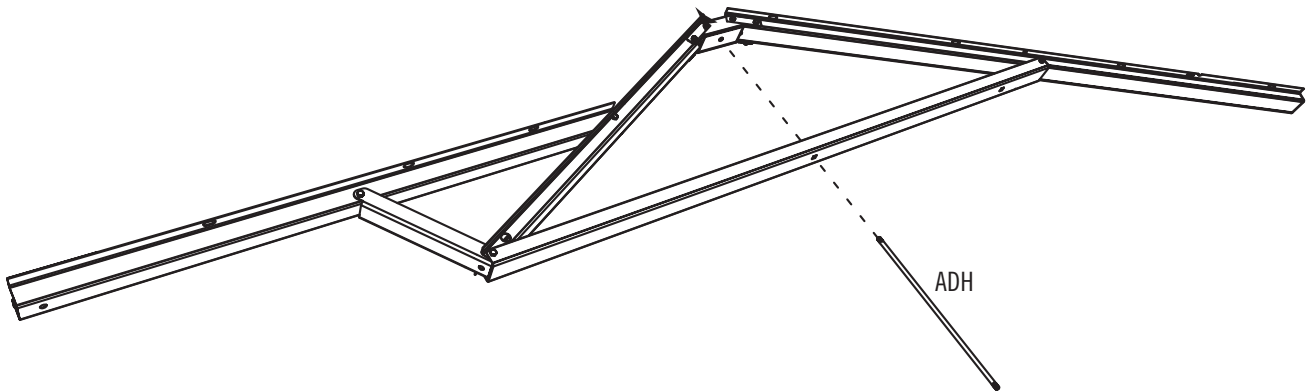

- *Note: Do not overtighten the Cap Nuts (ADJ).*
- *Remarque : Ne pas trop serrer les écrous borgnes (ADJ).*
- *Nota: No apretst demasiado las tuercas ciegas (ADJ).*

## ► SECTION 2 (CONTINUED) / SECTION 2 (SUITE) / SECCIÓN 2 (CONTINUACIÓN)

TOOLS AND HARDWARE REQUIRED / OUTILS ET QUINCAILLERIE REQUIS / INSTRUMENTAL Y HERRAJE REQUERIDOS



3/8 in/po  
(≈10 mm)

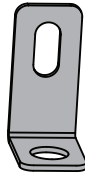

AHT (x1)

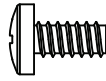

ADY (x1)



ADK (x1)

### 2.13

- Only tighten the **Nut (ADK)** by hand in this step.
- Ne serrer l'**écrou (ADK)** qu'à la main dans cette étape.
- Sólo apretar la **tuerca (ADK)** à mano en este paso.

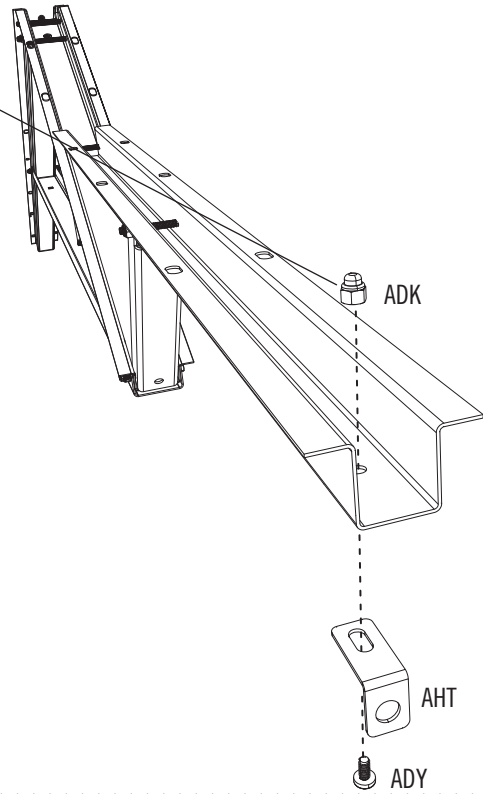

### 2.14

- Slide the **Support Tube (DSP)** through the hole in the Front Truss Channel and center it.
- Faire glisser le **tube de support (DSP)** à travers le trou dans le canal de gouttière avant et le centrer.
- Deslizar le **tubo de soporte (DSP)** a través del agujero en el canalón de la cercha delantero y centrarlo.

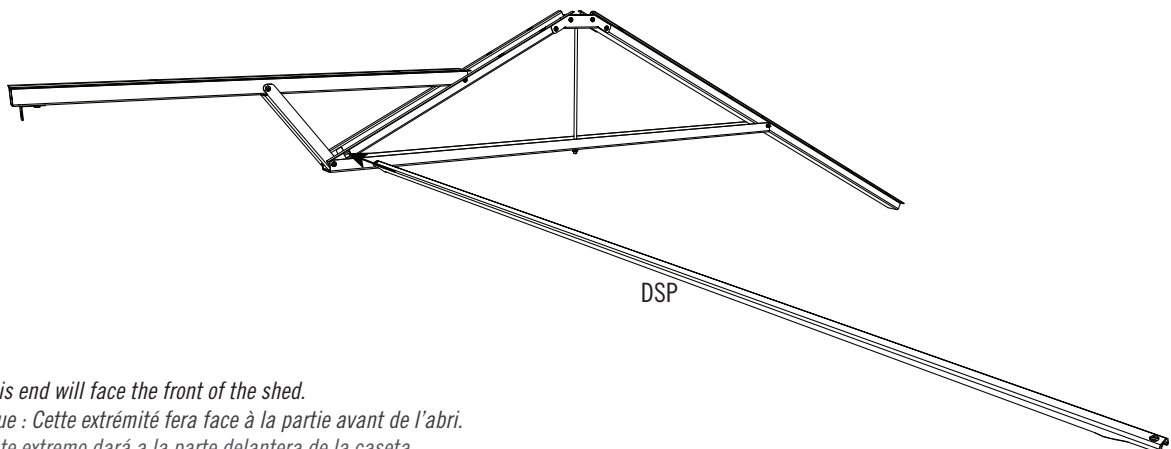

- **Note:** This end will face the front of the shed.
- **Remarque :** Cette extrémité fera face à la partie avant de l'abri.
- **Nota:** Este extremo dará a la parte delantera de la caseta.

# 3

## GABLE ASSEMBLY / ASSEMBLAGE DES PIGNONS / ENSAMBLE DE LAS FACHADAS



### HARDWARE REQUIRED / QUINCAILLERIE REQUISE / HERRAJE REQUERIDO

Hardware Bags / Sacs de quincaillerie / Bolsas de herraje

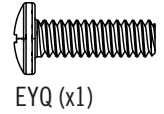
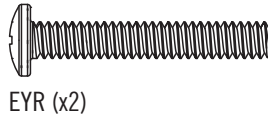
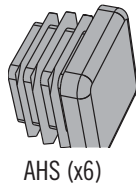
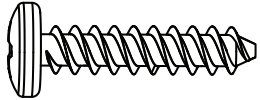
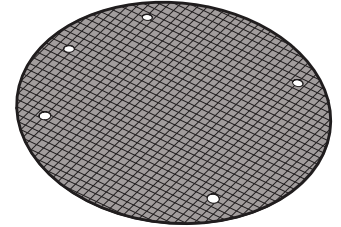
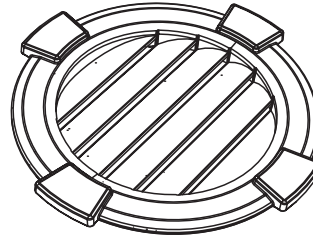
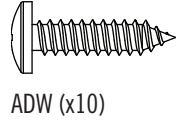
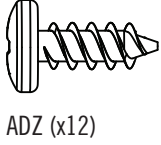

### PARTS REQUIRED / PIÈCES REQUISES / PIEZAS REQUERIDAS

Metal Part / Pièce en métal / Pieza de metal

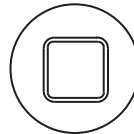
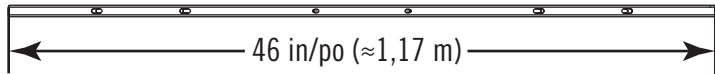
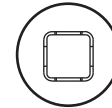

Plastic Parts / Pièces en plastique / Piezas de plástico

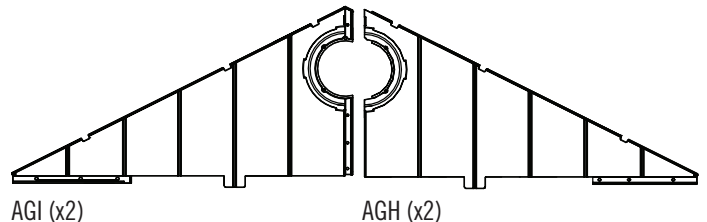
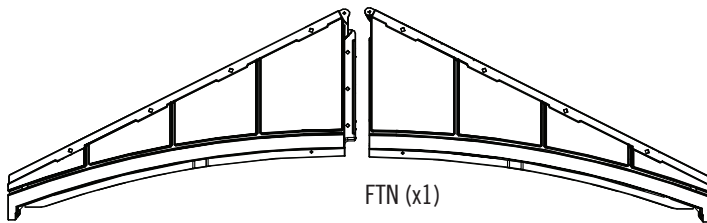

### TOOLS REQUIRED / OUTILS REQUIS / INSTRUMENTAL REQUERIDO



## ► SECTION 3 (CONTINUED) / SECTION 3 (SUITE) / SECCIÓN 3 (CONTINUACIÓN)

TOOLS AND HARDWARE REQUIRED / OUTILS ET QUINCAILLERIE REQUIS / INSTRUMENTAL Y HERRAJE REQUERIDOS

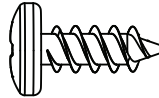

ADZ (x4)



- If you have trouble with this section, follow the code below to view a video on how to assemble these Gables.
- En cas de problèmes avec cette section, suivre le code en bas pour voir un vidéo sur l'assemblage de cette section.
- En caso de algún problema con esta sección, seguir el código debajo para ver un video sobre el ensamble de esta sección.

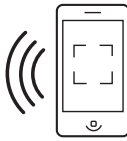

<http://go.lifetime.com/8segable2p>

### 3.1

- Align the holes in the **Side Gable Halves (AGH and AGI)**.
- Aligner les trous dans les **pignons latéraux (AGH et AGI)**.
- Alinear los agujeros en las **fachadas laterales (AGH y AGI)**.

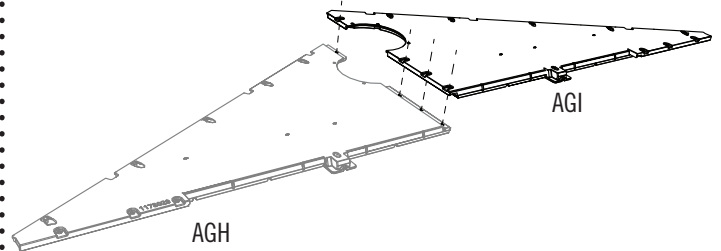

### 3.2

- Secure the two Gable Halves with four (4) **Screws (ADZ)**.
- Attacher l'un à l'autre à l'aide de quatre (4) **vis (ADZ)**.
- Sujetar el uno al otro usando cuatro (4) **tornillos (ADZ)**.

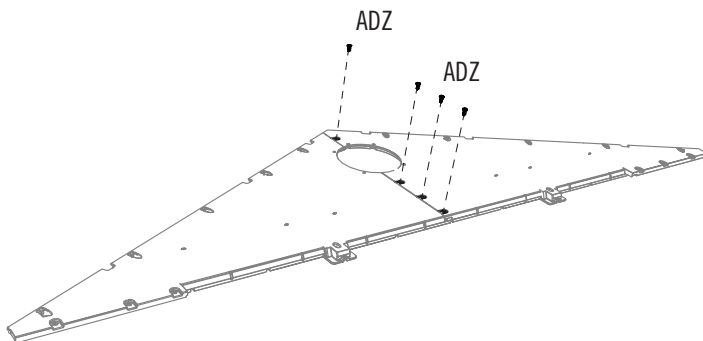

### 3.3

- Place the **Screen (AIQ)** over the **Vent (ENH)** and align the five holes in the Vent with those in the Gable.
- Mettre la **moustiquaire (AIQ)** sur l'**évent (ENH)**, et aligner les cinq trous dans l'évent avec ceux du pignon.
- Colocar el **mosquitero (AIQ)** sobre la **rejilla de ventilación (ENH)** y alinear los agujeros en la rejilla con los de la fachada.

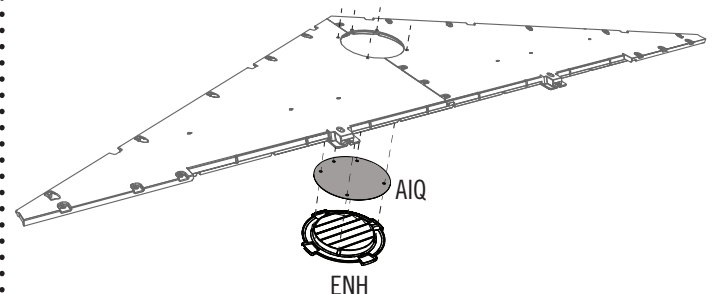

## ► SECTION 3 (CONTINUED) / SECTION 3 (SUITE) / SECCIÓN 3 (CONTINUACIÓN)

TOOLS AND HARDWARE REQUIRED / OUTILS ET QUINCAILLERIE REQUIS / INSTRUMENTAL Y HERRAJE REQUERIDOS

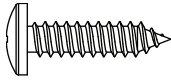

ADW (x5)

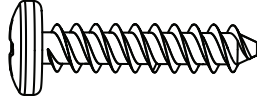

ADV (x6)

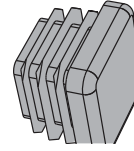

AHS (x2)

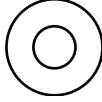

AEE (x5)

### 3.4

- Secure with the hardware provided.
- Fixer les uns aux autres en utilisant la quincaillerie incluse.
- Fijar los unos a los otros usando el herraje incluido.

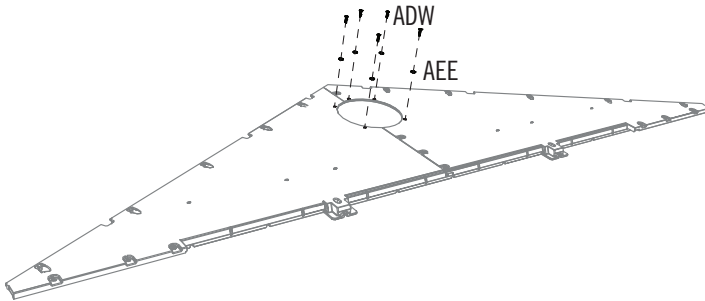

### 3.5

- Insert an **end cap (AHS)** into each end of the **square tube (AFE)**.
- Insérer un **caphuchon (AHS)** dans chaque extrémité de **tube carré (AFE)**.
- Insertar un **tapon (AHS)** en cada extremo del **tubo cuadrado (AFE)**.

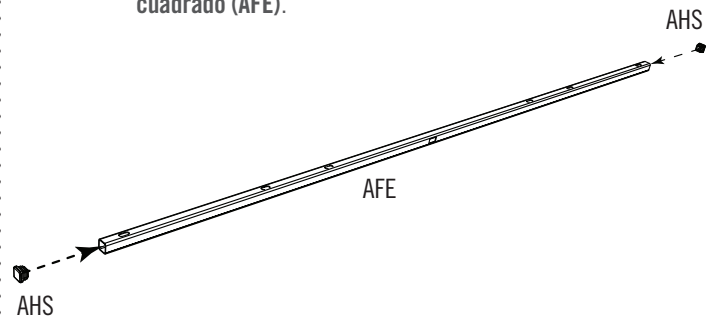

### 3.6

- Align the holes in the tube with those in the gable.
- Aligner les trous dans le tube avec ceux du pignon.
- Alinear los agujeros en el tubo con ellos en la fachada.

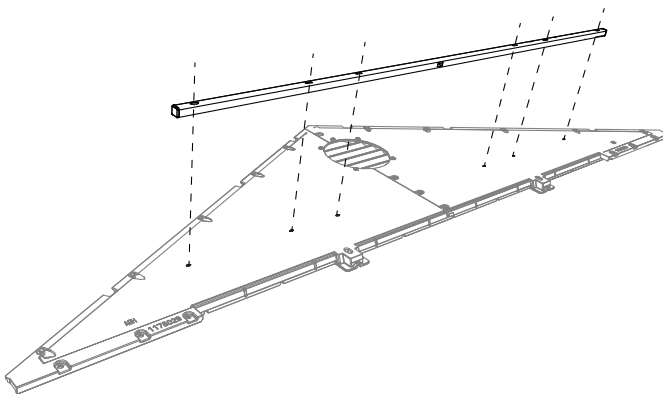

### 3.7

- Secure with the hardware provided.
- Fixer les uns aux autres en utilisant la quincaillerie incluse.
- Fijar los unos a los otros usando el herraje incluido.

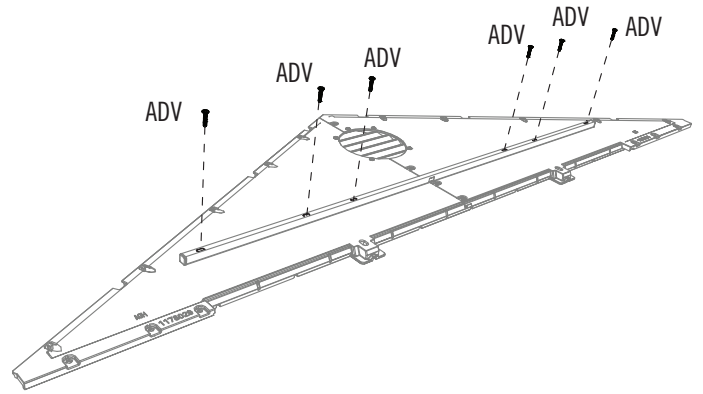

## ► SECTION 3 (CONTINUED) / SECTION 3 (SUITE) / SECCIÓN 3 (CONTINUACIÓN)

TOOLS AND HARDWARE REQUIRED / OUTILS ET QUINCAILLERIE REQUIS / INSTRUMENTAL Y HERRAJE REQUERIDOS



10 mm

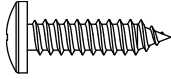

ADW (x5)



EYQ (x1)

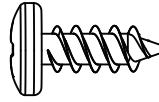

ADZ (x7)

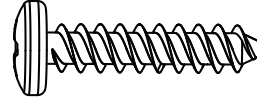

ADV (x6)

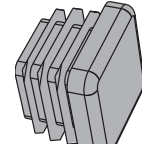

AHS (x2)

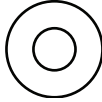

AEE (x5)



CXK (x1)

### 3.8

- Repeat the previous steps for the second Side Gable.
- Répéter les étapes précédentes pour le deuxième pignon latéral.
- Repetir los pasos anteriores para la segunda fachada lateral.

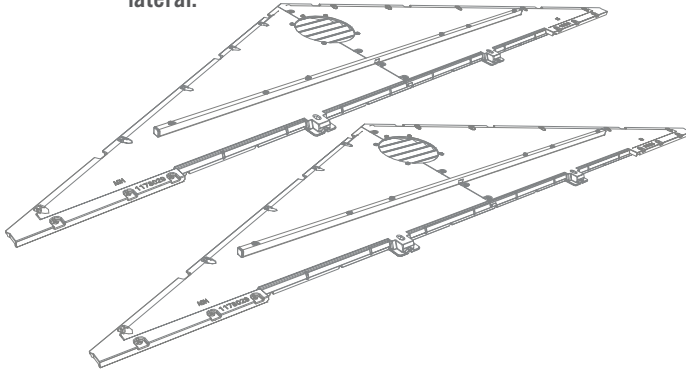

### 3.9

- Align the holes in the **Left (FTM)** and **Right (FTN)** Rear Gable Halves.
- Aligner les trous dans les **pignons gauche (FTM)** et **droite (FTN)**.
- Alinear los agujeros en las **fachadas traseras izquierda (FTM)** y **derecha (FTN)**.

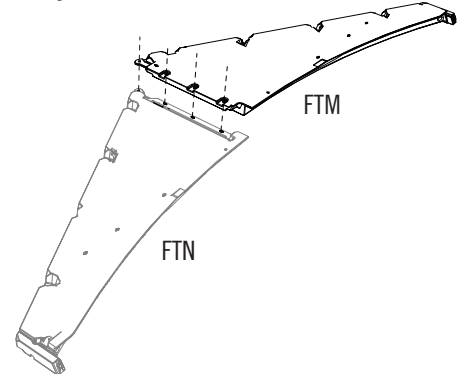

### 3.10

- Secure the two Gable Halves with three (3) **Screws (ADZ)** and one **Screw (EYQ)** and **Nut (CXK)**.
- Attacher l'un à l'autre à l'aide de trois (3) **vis (ADZ)** et une **vis (EYQ)** et une **écrou (CXK)**.
- Sujetar el uno al otro usando tres (3) **tornillos (ADZ)** y un **tornillo (EYQ)** y una **tuerca (CXK)**.

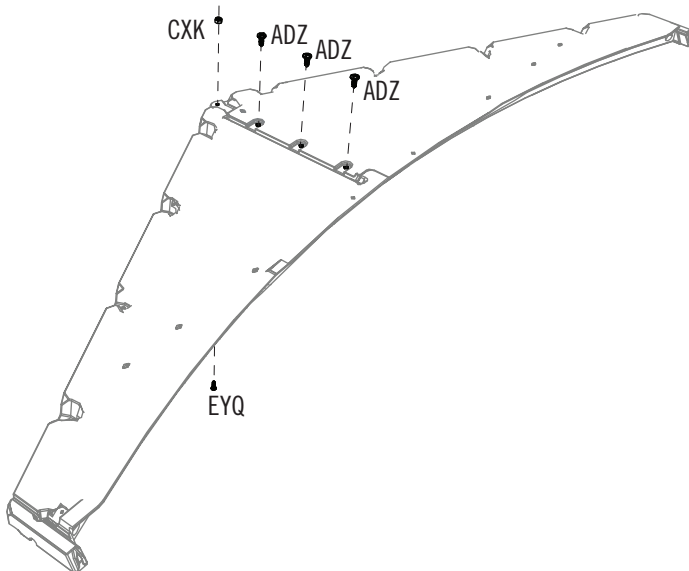

### 3.11

- Insert an **End Cap (AHS)** into each end of the **Header (FTW)**.
- Insérer un capuchon dans chaque extrémité du **linteau (FTW)**.
- Insertar un **tapón (AHS)** en los dos extremos del **dintel (FTW)**.

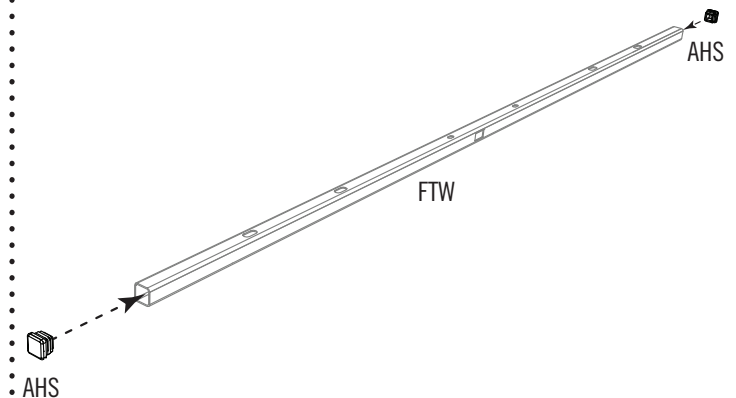

## ► SECTION 3 (CONTINUED) / SECTION 3 (SUITE) / SECCIÓN 3 (CONTINUACIÓN)

TOOLS AND HARDWARE REQUIRED / OUTILS ET QUINCAILLERIE REQUIS / INSTRUMENTAL Y HERRAJE REQUERIDOS



10 mm

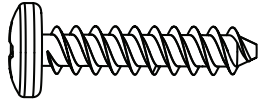

ADV (x4)

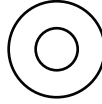

AEE (x2)



ADK (x2)

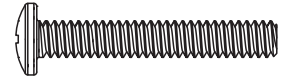

EYR (x2)

### 3.12

- Align the holes in the Header with those in the Entry Gable.
- Aligner les trous dans le linteau avec ceux du pignon d'entrée.
- Alinear los agujeros en el dintel con ellos en la fachada de entrada.



- The flat holes face away from the Gable.
- Les trous plats doivent être face à l'écart du pignon.
- Los agujeros planos dan hacia afuera.

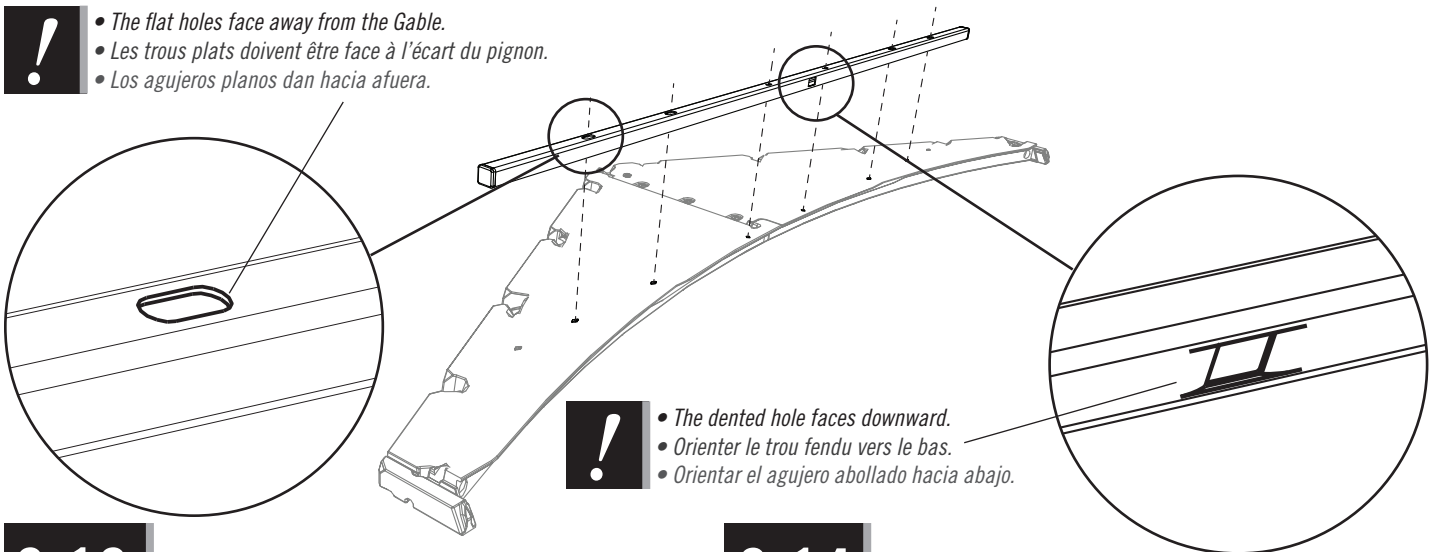

- The dented hole faces downward.
- Orienter le trou fendu vers le bas.
- Orientar el agujero abollado hacia abajo.

### 3.13

- Secure with four **Screws (ADV)**.
- Fixer avec quatre **vis (ADV)**.
- Fijar con cuatro  **tornillos (ADV)**.

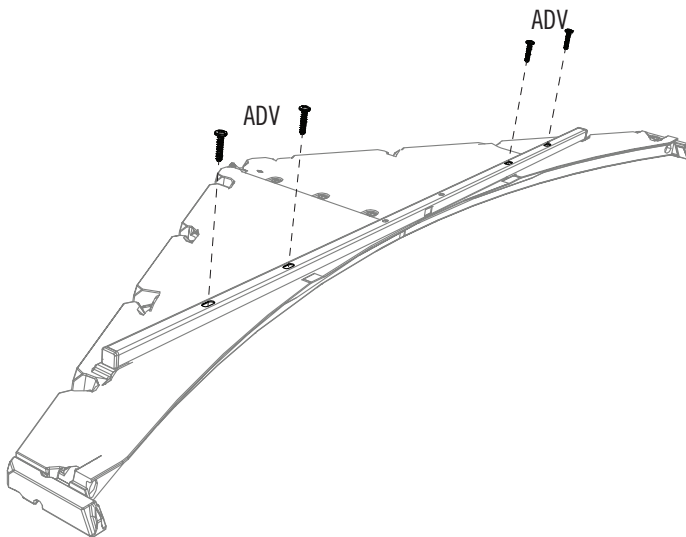

### 3.14

- Secure with two **Screws (EYR)**, two **Washers (AEE)**, and two **Nuts (ADK)**.
- Fixer avec deux **vis (EYR)**, deux **rondelles (AEE)**, et deux **écrous (ADK)**.
- Fijar con dos **tornillos (EYR)**, dos **rondanas (AEE)**, y dos **tuercas (ADK)**.

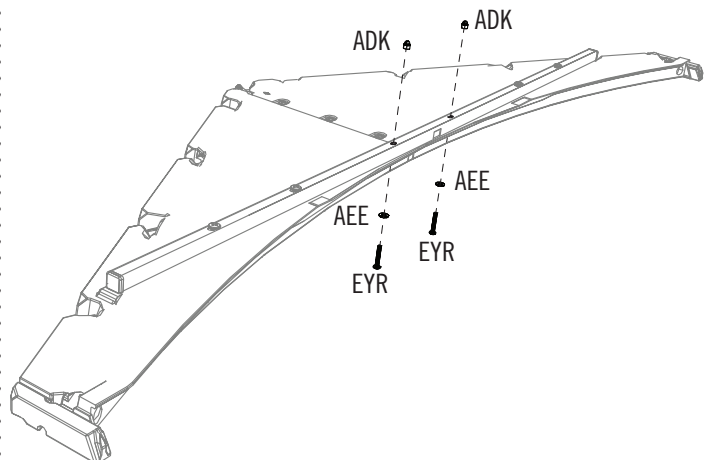



# 4

## LEFT DOOR ASSEMBLY / ASSEMBLAGE DE LA PORTE GAUCHE / ENSAMBLE DE LA PUERTA IZQUIERDA



### HARDWARE REQUIRED / QUINCAILLERIE REQUISE / HERRAJE REQUERIDO

Hardware Bag / Sac de quincaillerie / Bolsa de herraje

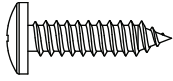

ADW (x1)

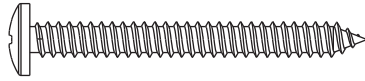

BYZ (x2)



ADJ (x2)

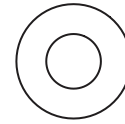

AEB (x2)

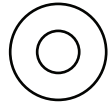

AEE (x3)

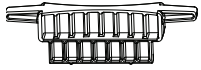

AHM (x2)

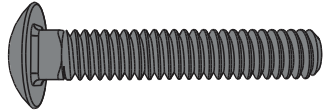

ACH (x2)

Parts / Pièces / Piezas

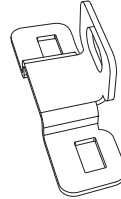

ECY (x1)

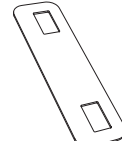

ECX (x1)

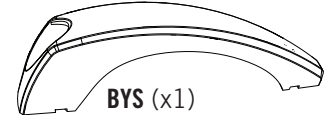

BYS (x1)



BYR (x1)

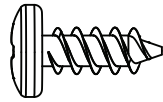

ADZ (x28)



EPH (x1)



### PARTS REQUIRED / PIÈCES REQUISES / PIEZAS REQUERIDAS

Metal Parts / Pièces en métal / Piezas de metal

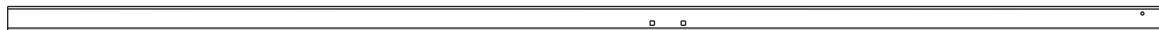

BLH (x1)

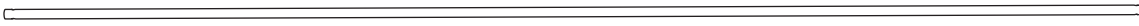

CRE (x1)

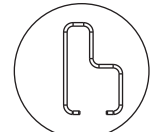

Plastic Parts / Pièces en plastique / Piezas de plástico

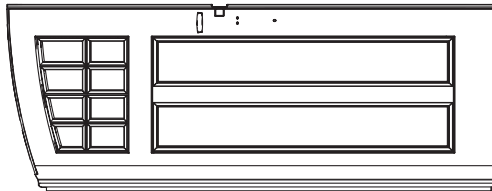

BDJ (x1)

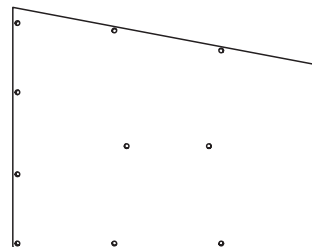

DHN (x1)



### TOOLS REQUIRED / OUTILS REQUIS / INSTRUMENTAL REQUERIDO

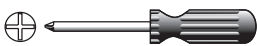

7/16 in/po  
(11 mm)

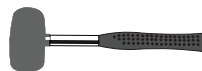

## ► SECTION 4 (CONTINUED) / SECTION 4 (SUITE) / SECCIÓN 4 (CONTINUACIÓN)

TOOLS AND HARDWARE REQUIRED / OUTILS ET QUINCAILLERIE REQUIS / INSTRUMENTAL Y HERRAJE REQUERIDOS



- If you have trouble with this section, follow the code below to view a video on the assembly in this section.
- En cas d'avoir des problèmes avec cette section, suivre le code en bas pour voir un vidéo sur l'assemblage dans cette section.
- En caso de tener problemas con esta sección, seguir el código debajo para ver un video sobre el ensamble en esta sección.



### 4.1

- Slide a **Hinge Tube (CRE)** down into the hole at the top of the **Left Door (BDJ)**.
- Faire glisser le **tube d'articulation (CRE)** dans le trou au bord supérieur de la **porte gauche (BDJ)**.
- Deslizar el **tubo de articulación (CRE)** en el agujero a la parte superior de la **puerta izquierda (BDJ)**.

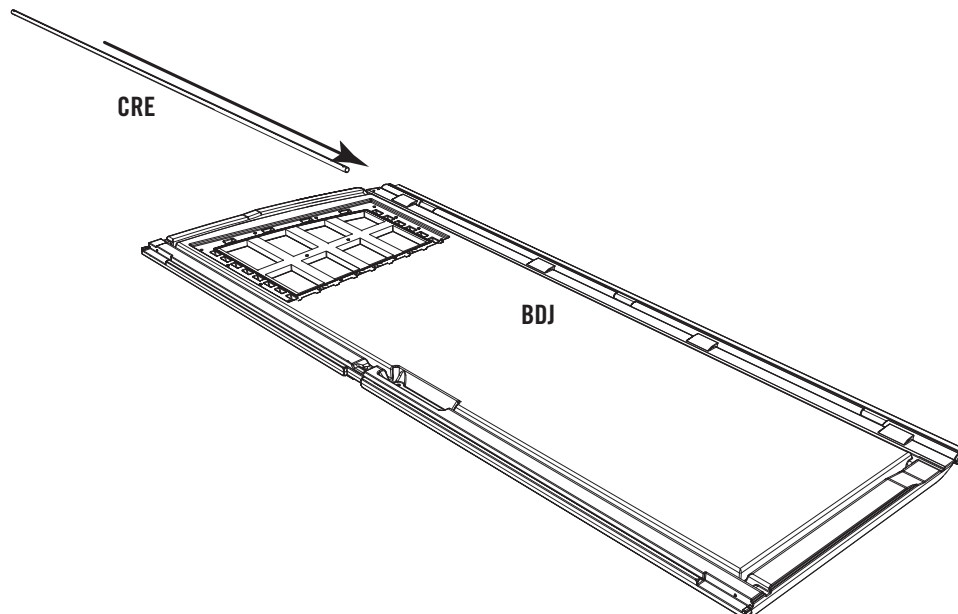

## ► SECTION 4 (CONTINUED) / SECTION 4 (SUITE) / SECCIÓN 4 (CONTINUACIÓN)

TOOLS AND HARDWARE REQUIRED / OUTILS ET QUINCAILLERIE REQUIS / INSTRUMENTAL Y HERRAJE REQUERIDOS

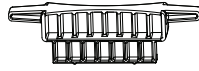

AHM (x2)



.....  
• Door Channels (BLH) are specifically designed to bow. This ensures a tight fit when they are closed and latched, making your shed more secure. These channels are formed with a slight bend to the adjoining door edge—like parentheses facing each other: ( ). When the door handle is gently closed and latched, there should be a slight pressure sealing the doors and eliminating any gaps. Be sure to read the step-by-step instructions carefully to successfully install the door channels.

• Les canaux pour le bord des portes (BLH) sont conçus spécifiquement avec une courbe. Cette courbe s'assure un ajustage lorsque les portes se ferment, en faisant l'abri plus sûr. Ces canaux sont fabriqués avec une légère courbe au bord de la porte adjacent — comme les parenthèses qui font face l'une l'autre : ( ). Lorsque la poignée se ferme, il devrait un légère pression en rebouchant les portes et en éliminant des ouvertures. Veiller à lire avec soin les instructions étape par étape pour pouvoir installer avec succès les canaux pour le bord des portes.

• Los canales para el borde de las puertas (BLH) son diseñados específicamente con una curva. Esta curva asegure un ajuste fijo cuando las puertas estén cerrados con pestillo, haciendo la caseta más segura. Estos canales están formados con una curva ligera al borde de la puerta adyacente, como los paréntesis uno enfrente al otro: ( ). Cuando el picaporte esté ligeramente cerrado con pestillo, debería tener una presión ligera sellando las puertas y eliminando los espacios. Asegurarse de leer detenidamente las instrucciones paso a paso para poder instalar exitosamente los canales para el borde de las puertas.

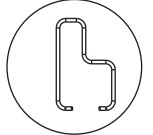

### 4.2

BLH

.....  
• Set the **Deadbolts (AHM)** down into the recesses at the top and bottom of the Door. Then, slide the **Door End Channel (BLH)** over the edge of the Door and the bottom of the Deadbolts as shown.

• Mettre les **loquets à pêne dormant (AHM)** dans les espaces vides aux parties supérieure et inférieure de la porte. Ensuite, faire glisser le **canal de la porte (BLH)** sur le bord de la porte et les parties inférieures des loquets à pêne dormant comme illustré.

• Poner los **cerrojos (AHM)** en los huecos a las partes superior e inferior de la puerta. Entonces, deslizar el **canal para el borde de la puerta (BLH)** sobre el borde de la puerta y las partes inferiores de los cerrojos como se muestra.

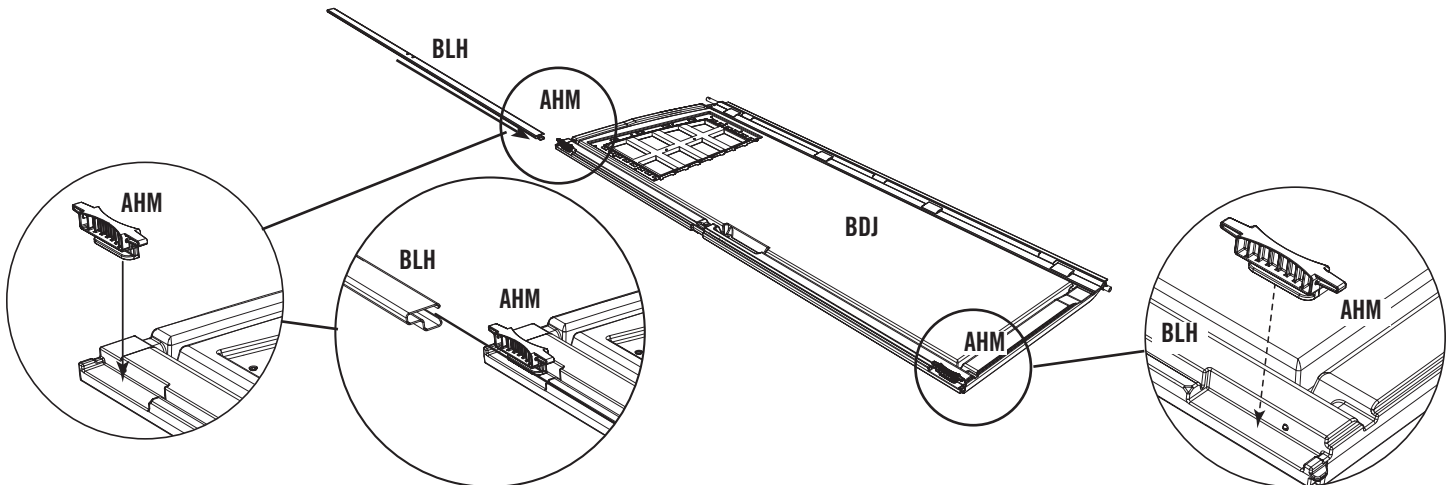

## ► SECTION 4 (CONTINUED) / SECTION 4 (SUITE) / SECCIÓN 4 (CONTINUACIÓN)

TOOLS AND HARDWARE REQUIRED / OUTILS ET QUINCAILLERIE REQUIS / INSTRUMENTAL Y HERRAJE REQUERIDOS

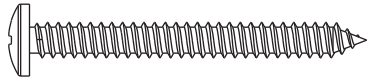

BYZ (x2)

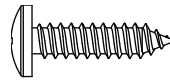

ADW (x1)

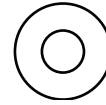

AEE (x3)



• *Note: The Deadbolts are used for locking the door. They may not move freely at first. You may need to tap them up and down a few times with a rubber mallet to work them in.*

• *Remarque : On utilise les loquets pour fermer la porte. Au debut, il se peut que les loquets ne se déplaceraient librement. Vous devrez peut-être les taper légèrement à l'aide d'un maillet en caoutchouc pour les desserrer.*

• *Nota: Se usan los cerrojos para cerrar la puerta. Al principio, pueden que no se desplacen libremente. Puede que necesite darlos unos golpecitos con un mazo de goma para aflojarlos.*

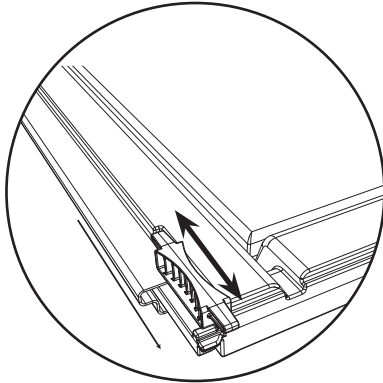

### 4.3

• Attach the two **Handle Pieces (BYR & BYS)** together as shown.

• Attacher les deux pièces de la **poignée (BYR et BYS)** comme illustré.

• Conectar las dos piezas del **picaporte (BYR y BYS)** como se muestra.

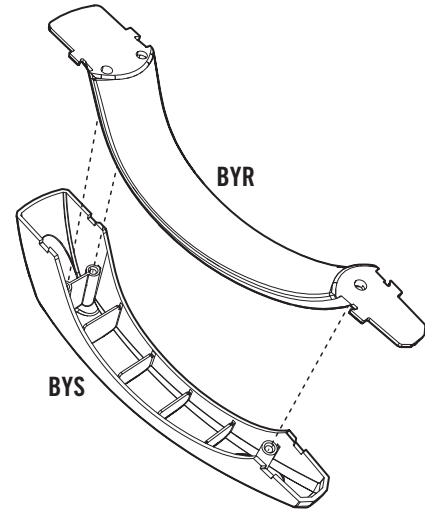

### 4.4

• Attach the Handle to the Door using the hardware provided. **Do not overtighten.**

• Attacher la poignée à la porte à l'aide de la quincaillerie incluse. **Ne pas trop serrer.**

• Sujetar el picaporte a la puerta usando el herraje incluido. **No apretar demasiado.**

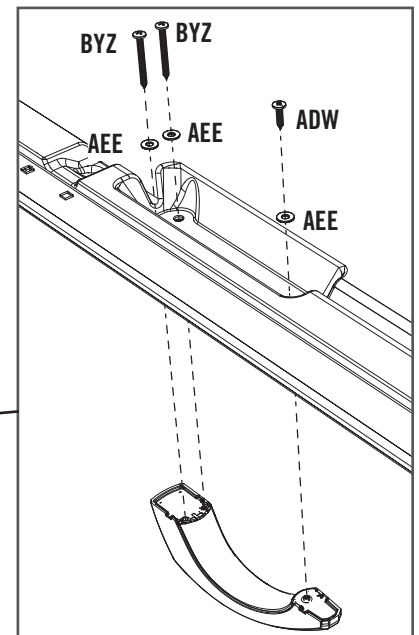
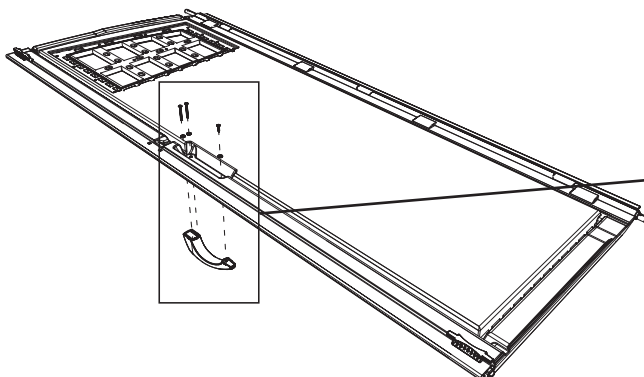

## ► SECTION 4 (CONTINUED) / SECTION 4 (SUITE) / SECCIÓN 4 (CONTINUACIÓN)

TOOLS AND HARDWARE REQUIRED / OUTILS ET QUINCAILLERIE REQUIS / INSTRUMENTAL Y HERRAJE REQUERIDOS



7/16 in/po  
(11 mm)

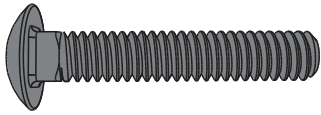

ACH (x2)

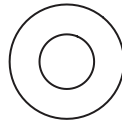

AEB (x2)



ADJ (x2)

### 4.5

- Attach the **Strike Plate (ECX)** and **Lock Bracket (ECY)** to the Channel as shown. **Only hand-tighten the hardware for now.**
- Attacher la **gâche (ECX)** y la **plaque de verrouillage (ECY)** au canal comme illustré. **Serrer la quincaillerie à la main seulement en ce moment.**
- Sujetar la **placa de impacto (ECX)** y la **placa de cierre (ECY)** al canal como se muestra. **Apretar el herraje sólo a mano en este momento.**

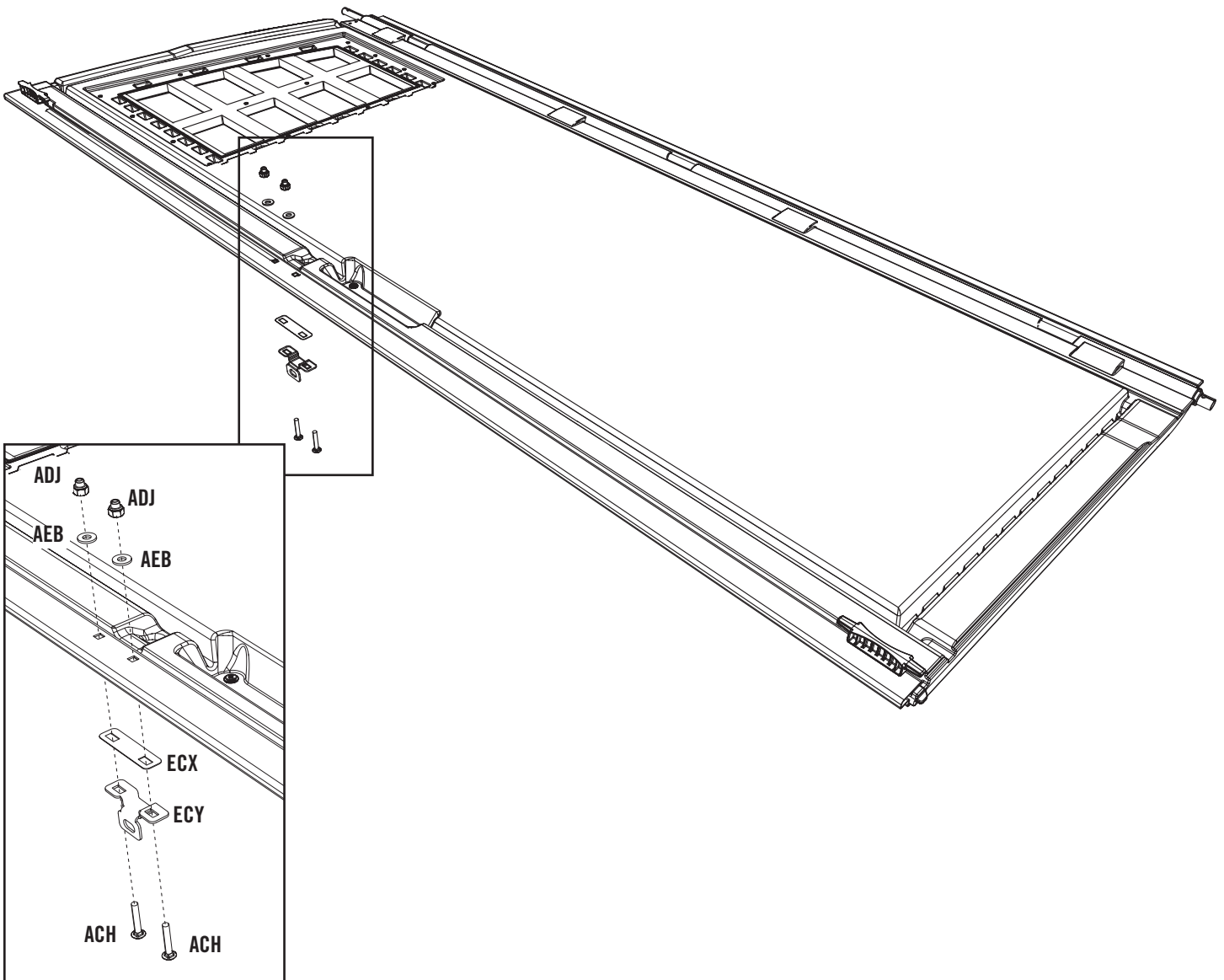

## ► SECTION 4 (CONTINUED) / SECTION 4 (SUITE) / SECCIÓN 4 (CONTINUACIÓN)

TOOLS AND HARDWARE REQUIRED / OUTILS ET QUINCAILLERIE REQUIS / INSTRUMENTAL Y HERRAJE REQUERIDOS



### 4.6

• There is a narrow groove (illustrated in black) running along the outside of the window on the back of each Door. Starting at the top, left corner of the groove in the Left Door, lay the 1/8" (3,2 mm) bead of **Butyl Tape (EPH)** into the groove. **Do not worry about getting the bead completely into the groove just yet—simply lay the bead over the groove. Do not press the bead into the groove.** Work your way downward (1), and curve to go along the bottom (2) of the window. Curve your way upward (3) and then along the top (4) of the window until you're back where you started. **Clip off the excess.**

• Une rainure étroite (illustrée en noir) se trouve le long de l'extérieur de la fenêtre à l'arrière de chaque porte. Partant du coin supérieur gauche de la rainure de la porte gauche, étendre une goutte de 1/8 po (3,2 mm) de **ruban de caoutchouc butyl (EPH)** dans la rainure. **Ne pas s'inquiéter si la goutte n'est pas complètement dans la rainure en ce moment, ne faire que déposer la goutte sur la rainure.** Ne pas pousser la goutte dans la rainure. Travailler vers le bas (1), et courber pour atteindre le bas (2) de la fenêtre. Courber vers le haut (3), puis le long du haut (4) de la fenêtre jusqu'à revenir au point de départ. **Couper l'excédent.**

• Hay una ranura angosta (ilustrada en negro) bordeando la ventana en la superficie posterior de cada puerta. Comenzando desde arriba, en la esquina izquierda de la ranura en la puerta izquierda, aplicar una línea de 3 mm (1/8 in) de **cinta butílica (EPH)** en de la ranura. **Ne preocuparse por poner la cinta, mas solamente ponga la cinta sobre la ranura. No presionar la cinta dentro de la ranura.** Seguir hacia abajo (1), y curvarla a lo largo del borde inferior (2) de la ventana. Curvarla hacia arriba (3) y, entonces, a lo largo del borde superior (4) de la ventana hasta estar al punto de partida. **Cortar el exceso.**

Groove / Rainure / Ranura



EPH (x1)

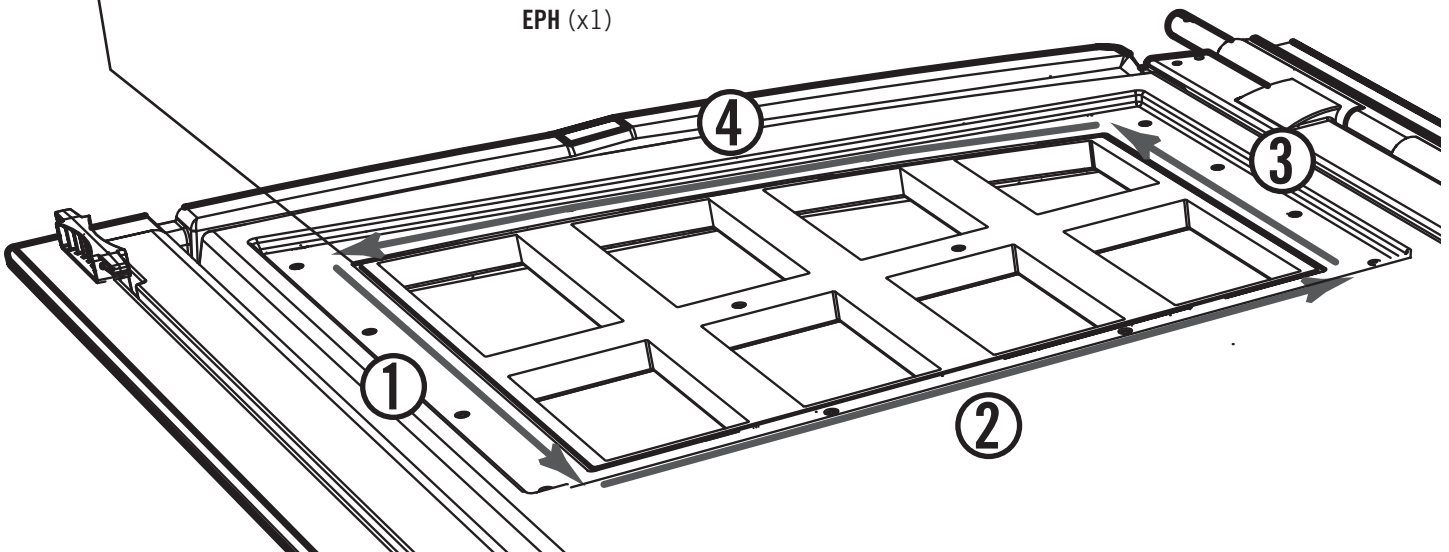

## ► SECTION 4 (CONTINUED) / SECTION 4 (SUITE) / SECCIÓN 4 (CONTINUACIÓN)

TOOLS AND HARDWARE REQUIRED / OUTILS ET QUINCAILLERIE REQUIS / INSTRUMENTAL Y HERRAJE REQUERIDOS

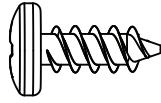

ADZ (x14)

### 4.7

- Peel off the protective backing from both sides of **Window Pane (DHN)**. Align the holes in the Pane with those in the Door, and gently set a Window Pane down onto the Door.
- Retirer la pellicule protectrice des deux côtés du **carreau (DHN)**. Aligner les trous dans le carreau avec ceux de la porte, et, avec douceur, mettre le carreau sur la porte.
- Retirar el protector de plástico de las dos caras de una **hoja (DHN)**. Alinear los agujeros en la hoja con los de la puerta, y colocar ligeramente la hoja de ventana en la puerta.

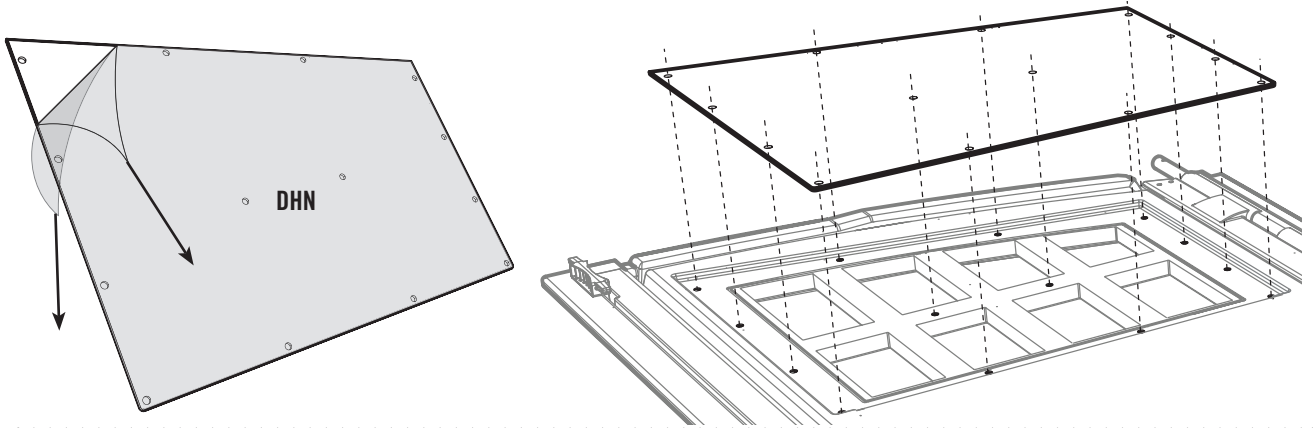

### 4.8

- Secure the Pane to the Door using fourteen (14) **Screws (ADZ)**.
- Fixer le carreau à la porte en utilisant quatorze (14) **vis (ADZ)**.
- Fijar la hoja a la puerta usando catorce (14) **tornillos (ADZ)**.

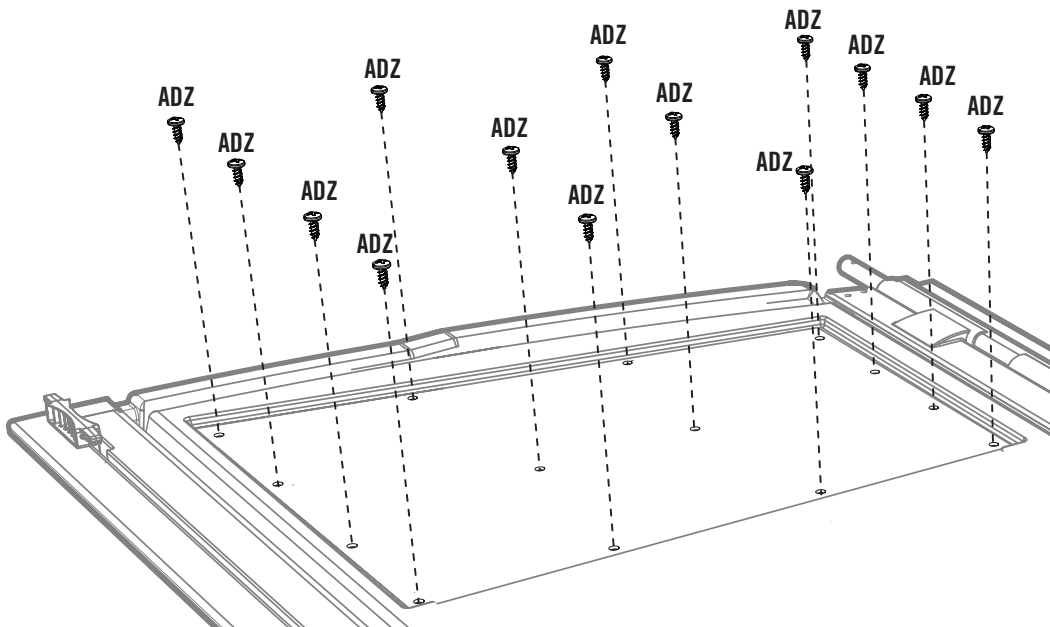



# 5

## RIGHT DOOR ASSEMBLY / ASSEMBLAGE DE LA PORTE DROITE / ENSAMBLE DE LA PUERTA DERECHA



### HARDWARE REQUIRED / QUINCAILLERIE REQUISE / HERRAJE REQUERIDO

Hardware Bag / Sac de quincaillerie / Bolsa de herraje

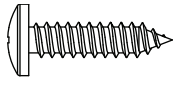

ADW (x1)

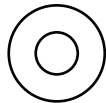

AEE (x1)

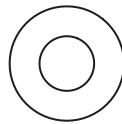

AEB (x2)

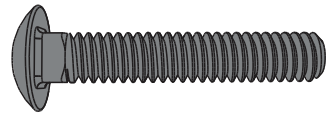

ACH (x2)

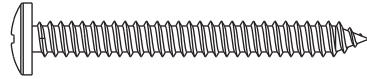

BYZ (x2)



ADJ (x2)

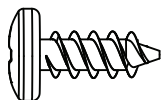

ADZ (x28)



EPH (x1)

Parts / Pièces / Piezas

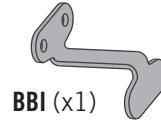

BBI (x1)

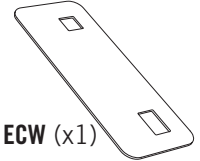

ECW (x1)

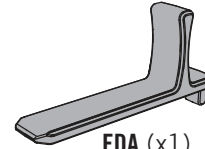

EDA (x1)

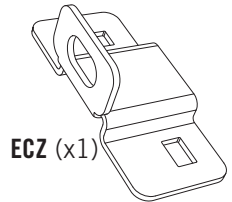

ECZ (x1)

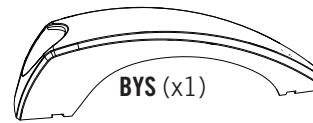

BYS (x1)



BYR (x1)



### PARTS REQUIRED / PIÈCES REQUISES / PIEZAS REQUERIDAS

Metal Parts / Pièces en métal / Piezas de metal



BLH (x1)

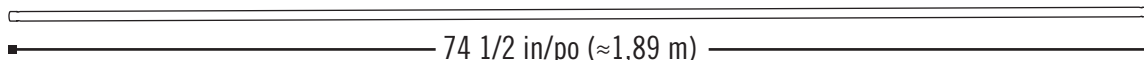
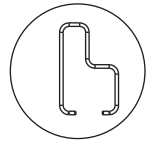

CRE (x1)



Plastic Parts / Pièces en plastique / Piezas de plástico

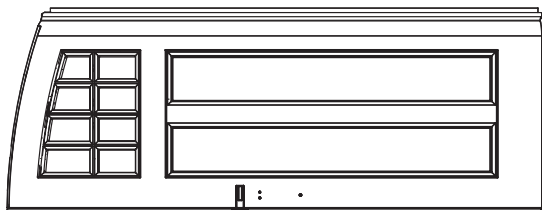

BDK (x1)

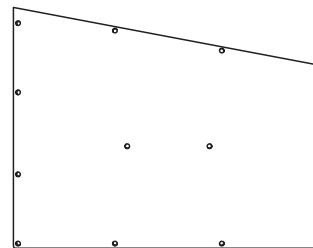

DHN (x1)



### TOOLS REQUIRED / OUTILS REQUIS / INSTRUMENTAL REQUERIDO

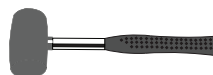

7/16 in/po (11 mm)

## ► SECTION 5 (CONTINUED) / SECTION 5 (SUITE) / SECCIÓN 5 (CONTINUACIÓN)

TOOLS AND HARDWARE REQUIRED / OUTILS ET QUINCAILLERIE REQUIS / INSTRUMENTAL Y HERRAJE REQUERIDOS



- If you have trouble with this section, follow the code below to view a video on the assembly in this section.
- En cas d'avoir des problèmes avec cette section, suivre le code en bas pour voir un vidéo sur l'assemblage dans cette section.
- En caso de tener problemas con esta sección, seguir el código debajo para ver un video sobre el ensamble en esta sección.

 YouTube

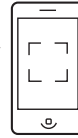

<http://go.lifetime.com/8rdwinsl>

### 5.1

- Slide a **Hinge Tube (CRE)** down into the hole at the top of the **Right Door (BDK)**.
- Faire glisser le **tube d'articulation (CRE)** dans le trou au bord supérieur de la **porte droite (BDK)**.
- Deslizar el **tubo de articulación (CRE)** en el agujero a la parte superior de la **puerta derecha (BDK)**.

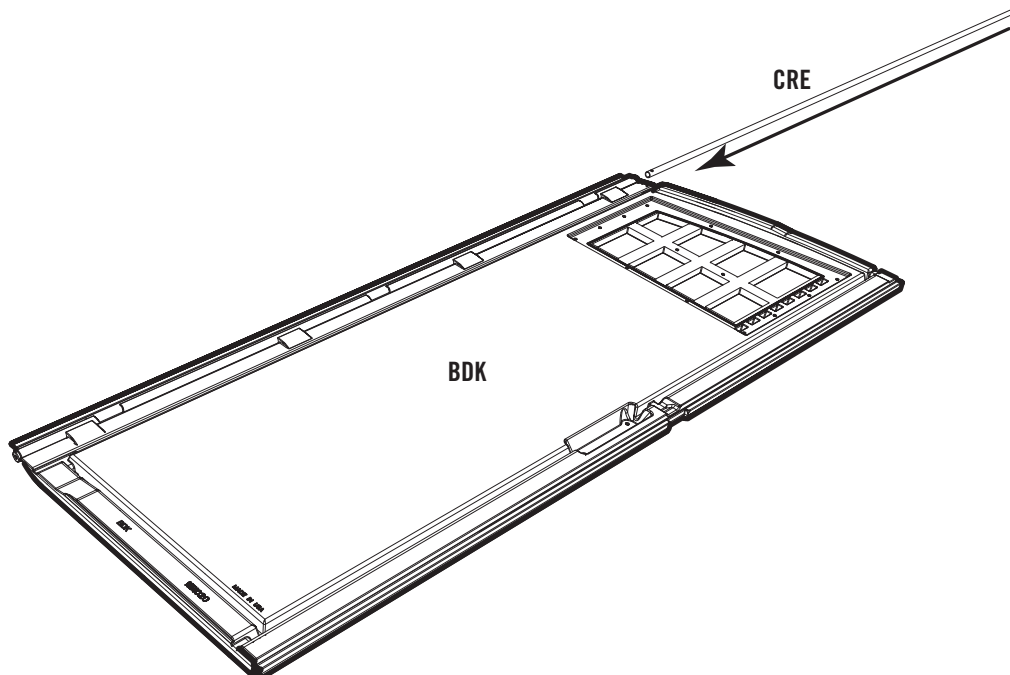

## ► SECTION 5 (CONTINUED) / SECTION 5 (SUITE) / SECCIÓN 5 (CONTINUACIÓN)

TOOLS AND HARDWARE REQUIRED / OUTILS ET QUINCAILLERIE REQUIS / INSTRUMENTAL Y HERRAJE REQUERIDOS



• Door Channels (BLH) are specifically designed to bow. This ensures a tight fit when they are closed and latched, making your shed more secure. These channels are formed with a slight bend to the adjoining door edge—like parentheses facing each other: ( ). When the door handle is gently closed and latched, there should be a slight pressure sealing the doors and eliminating any gaps. Be sure to read the step-by-step instructions carefully to successfully install the door channels.

• Les canaux pour le bord des portes (BLH) sont conçus spécifiquement avec une courbe. Cette courbe s'assure un ajustage lorsque les portes se ferment, en faisant l'abri plus sûr. Ces canaux sont fabriqués avec une légère courbe au bord de la porte adjacente — comme les parenthèses qui font face l'une l'autre : ( ). Lorsque la poignée se ferme, il devrait y avoir une légère pression en rebouchant les portes et en éliminant des ouvertures. Veillez à lire avec soin les instructions étape par étape pour pouvoir installer avec succès les canaux pour le bord des portes.

• Los canales para el borde de las puertas (BLH) son diseñados específicamente con una curva. Esta curva asegure un ajuste fijo cuando las puertas estén cerrados con pestillo, haciendo la caseta más segura. Estos canales están formados con una curva ligera al borde de la puerta adyacente, como los paréntesis uno enfrente al otro: ( ). Cuando el picaporte esté ligeramente cerrado con pestillo, debería tener una presión ligera sellando las puertas y eliminando los espacios. Asegurarse de leer detenidamente las instrucciones paso a paso para poder instalar exitosamente los canales para el borde de las puertas.

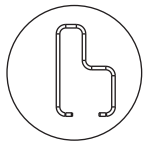

BLH

### 5.2

- Slide the **Door End Channel (BLH)** over the edge of the Door as shown.
- Faire glisser le **canal de la porte (BLH)** sur le bord de la porte comme illustré.
- Deslizar el **canal para el borde de la puerta (BLH)** sobre el borde de la puerta como se muestra.

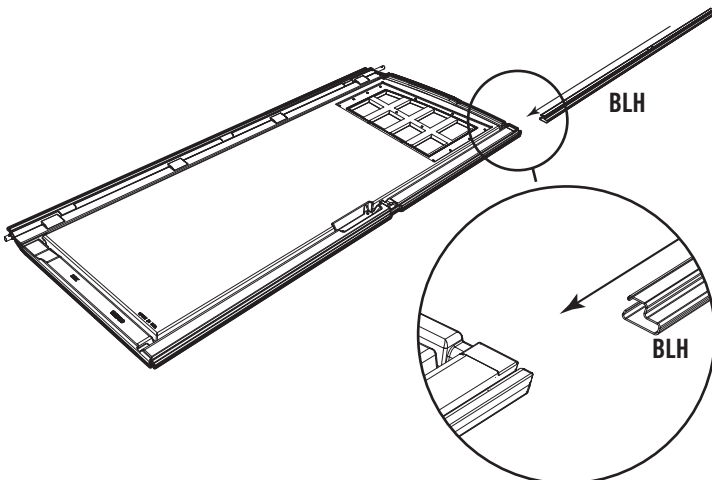

### 5.3

- Attach the two **Handle Pieces (BYR & BYS)** together as shown.
- Attacher les deux pièces de la **poignée (BYR et BYS)** comme illustré.
- Conectar las dos piezas del **picaporte (BYR y BYS)** como se muestra.

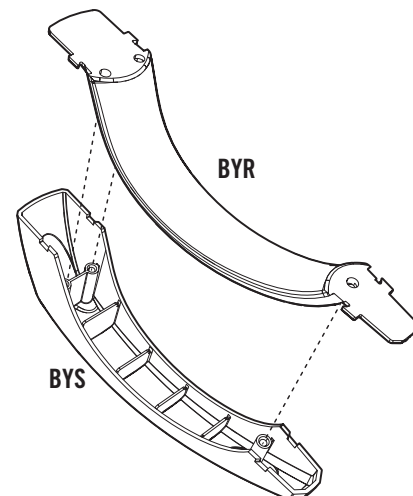

## ► SECTION 5 (CONTINUED) / SECTION 5 (SUITE) / SECCIÓN 5 (CONTINUACIÓN)

TOOLS AND HARDWARE REQUIRED / OUTILS ET QUINCAILLERIE REQUIS / INSTRUMENTAL Y HERRAJE REQUERIDOS



7/16 in/po  
(11 mm)



ADJ (x2)

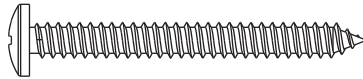

BYZ (x2)

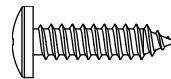

ADW (x1)

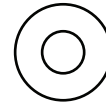

AEE (x1)

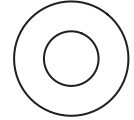

AEB (x2)

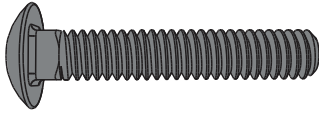

ACH (x2)

### 5.4

- Attach the Handle using the hardware provided.
- Attacher la poignée à l'aide de la quincaillerie incluse.
- Sujetar el picaporte usando el herraje incluido.

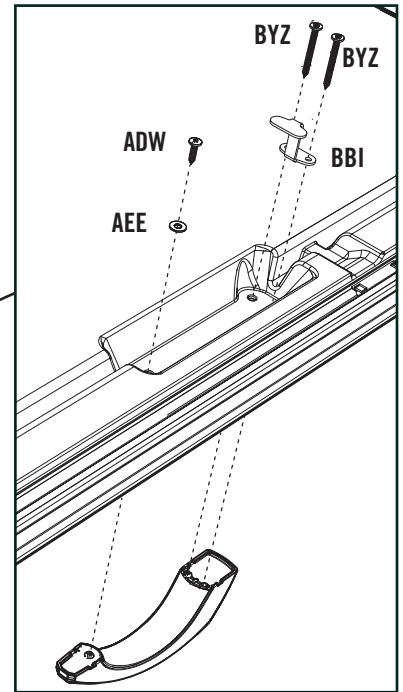
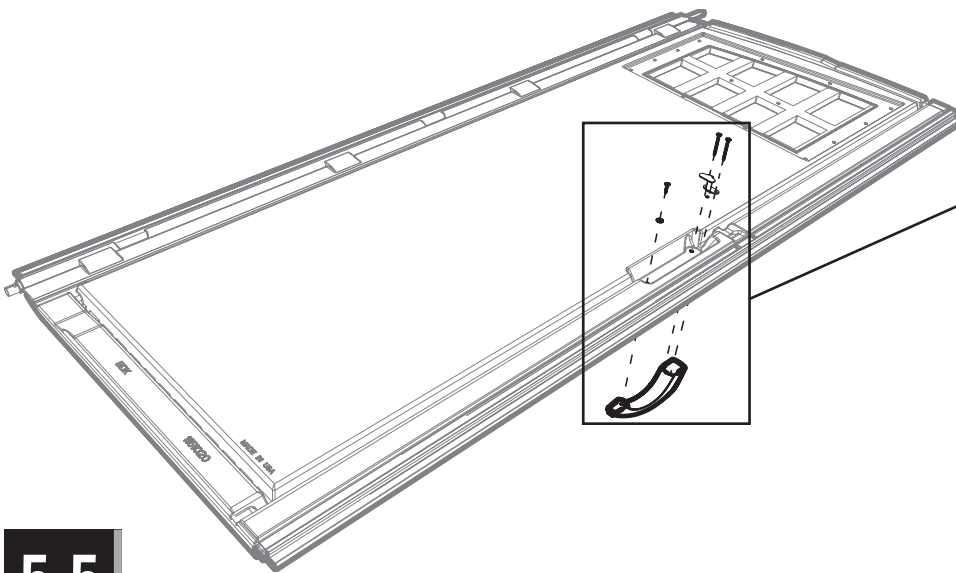

### 5.5

- Attach this Locking Hardware and tighten securely.
- Attacher bien cette quincaillerie de verrouillage.
- Sujetar bien este herraje de cierre.

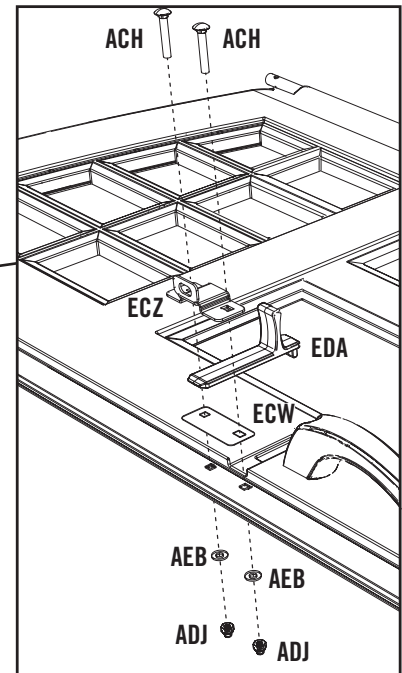
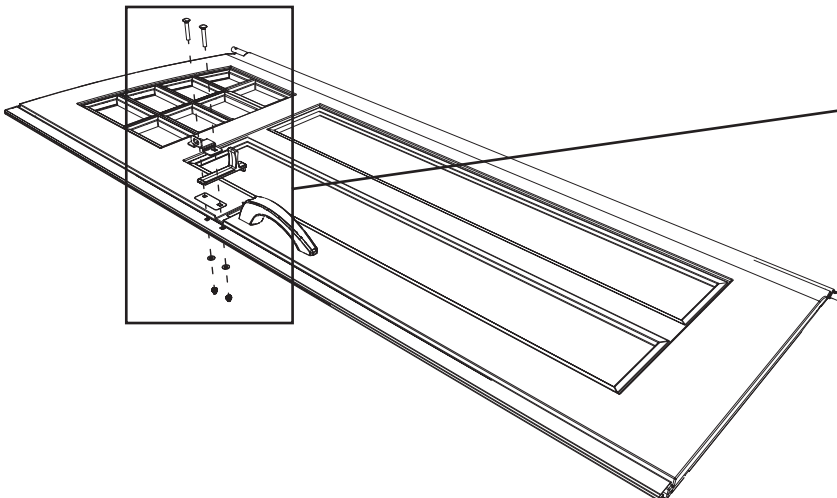

## ► SECTION 5 (CONTINUED) / SECTION 5 (SUITE) / SECCIÓN 5 (CONTINUACIÓN)

TOOLS AND HARDWARE REQUIRED / OUTILS ET QUINCAILLERIE REQUIS / INSTRUMENTAL Y HERRAJE REQUERIDOS



### 5.6

- There is a narrow groove (illustrated in black) running along the outside of the window on the back of each Door. Starting at the top, right corner of the groove in the Right Door, lay the 1/8" (3,2 mm) bead of **Butyl Tape (EPH)** into the groove. **Do not worry about getting the bead completely into the groove just yet—simply lay the bead over the groove. Do not press the bead into the groove.** Work your way downward (1), and curve to go along the bottom (2) of the window. Curve your way upward (3) and then along the top (4) of the window until you're back where you started. **Clip off the excess.**
- Une rainure étroite (illustrée en noir) se trouve le long de l'extérieur de la fenêtre à l'arrière de chaque porte. Partant du coin supérieur droit de la rainure de la porte droite, étendre une goutte de 1/8 po (3,2 mm) de **ruban de caoutchouc butyl (EPH)** dans la rainure. **Ne pas s'inquiéter si la goutte n'est pas complètement dans la rainure en ce moment, ne faire que déposer la goutte sur la rainure.** Ne pas pousser la goutte dans la rainure. Travailler vers le bas (1), et courber pour atteindre le bas (2) de la fenêtre. Courber vers le haut (3), puis le long du haut (4) de la fenêtre jusqu'à revenir au point de départ. **Couper l'excédent.**
- Hay una ranura angosta (ilustrada en negro) bordeando la ventana en la superficie posterior de cada puerta. Comenzando desde arriba, en la esquina derecha de la ranura en la puerta derecha, aplicar una línea de 3,2 mm (1/8 in) de **Cinta butílica (EPH)** en de la ranura. **Ne preocuparse por poner la cinta, mas solamente punta la cinta sobre la ranura. No presionar la cinta dentro de la ranura.** Seguir hacia abajo (1), y curvarla a lo largo del borde inferior (2) de la ventana. Curvarla hacia arriba (3) y, entonces, a lo largo del borde superior (4) de la ventana hasta estar al punto de partida. **Cortar el exceso.**

Groove / Rainure / Ranura

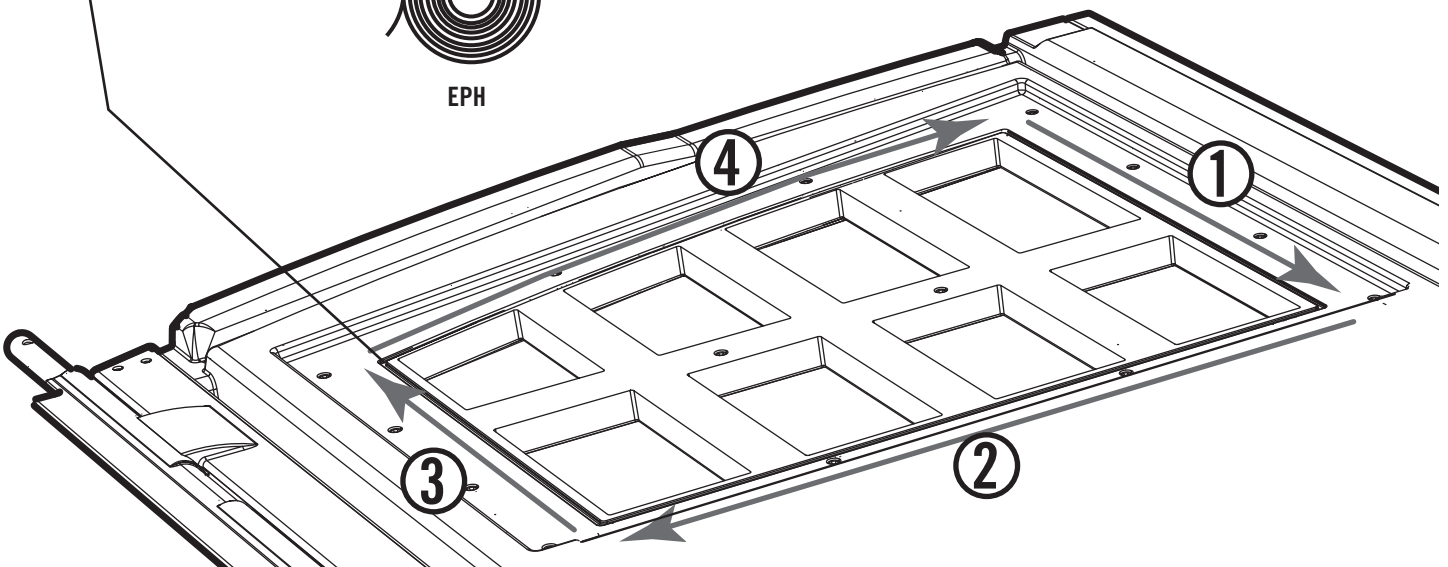

## ► SECTION 5 (CONTINUED) / SECTION 5 (SUITE) / SECCIÓN 5 (CONTINUACIÓN)

TOOLS AND HARDWARE REQUIRED / OUTILS ET QUINCAILLERIE REQUIS / INSTRUMENTAL Y HERRAJE REQUERIDOS

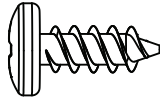

ADZ (x14)

### 5.7

- Peel off the protective backing from both sides of **Window Pane (DHN)**. Align the holes in the Pane with those in the Door, and gently set a Window Pane down onto the Door.
- Retirer la pellicule protectrice des deux côtés du **carreau (DHN)**. Aligner les trous dans le carreau avec ceux de la porte, et, avec douceur, mettre le carreau sur la porte.
- Retirar el protector de plástico de las dos caras de una **hoja (DHN)**. Alinear los agujeros en la hoja con los de la puerta, y colocar ligeramente la hoja de ventana en la puerta.

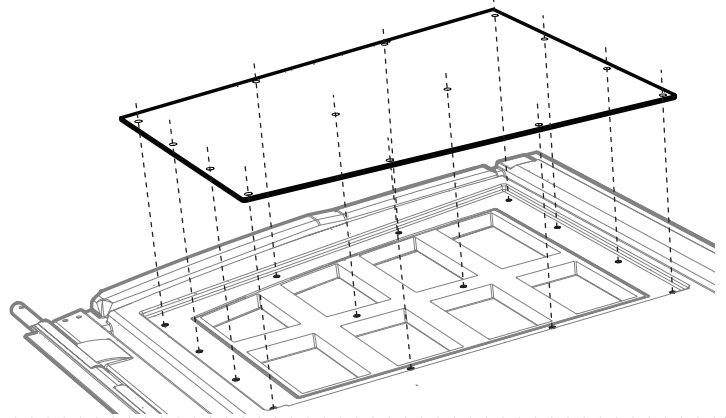
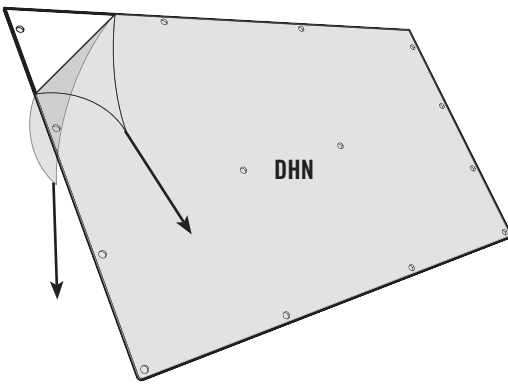

### 5.8

- Secure the Pane to the Door using fourteen (14) **Screws (ADZ)**.
- Fixer le carreau à la porte en utilisant quatorze (14) **vis (ADZ)**.
- Fijar la hoja a la puerta usando catorce (14) **tornillos (ADZ)**.

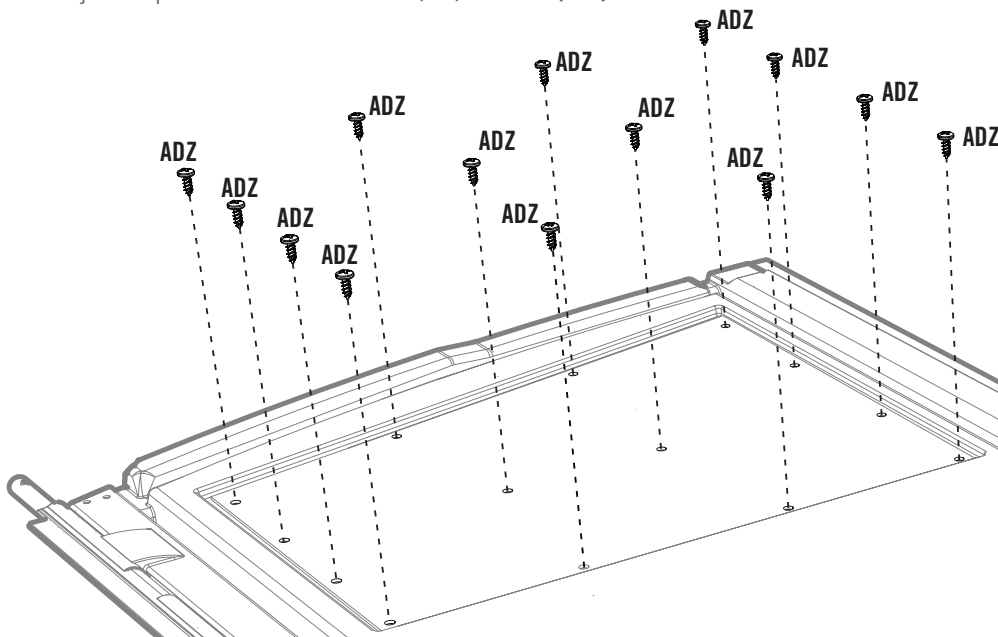

# 6

## FLOOR ASSEMBLY / ASSEMBLAGE DU PLANCHER / ENSAMBLE DEL PISO



### HARDWARE REQUIRED / QUINCAILLERIE REQUISE / HERRAJE REQUERIDO

Hardware Bag / Sac quincaillerie / Bolsa de herraje

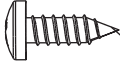

BQC (x20)

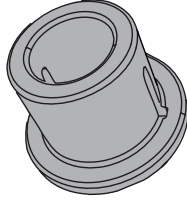

AHO (x2)



ADC (x1)



*Note: These Screws do not anchor the Floor; they only hold the Panels together.*

*Remarque : Ces vis n'ancrent pas le plancher; ils ne servent que pour attacher les panneaux les uns avec les autres.*

*Nota: Estos tornillos no anclan el piso; sirven sólo para sujetar los paneles los unos con los otros.*



### PARTS REQUIRED / PIÈCES REQUISES / PIEZAS REQUERIDAS

Plastic Parts / Pièces en plastique / Piezas de plástico

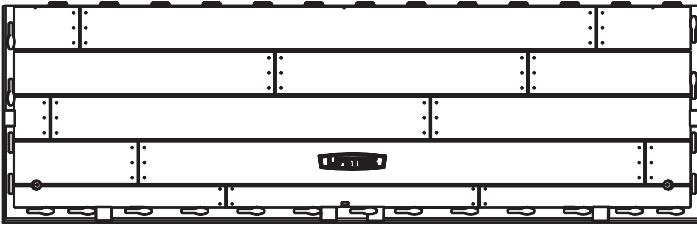

CUW (x2)

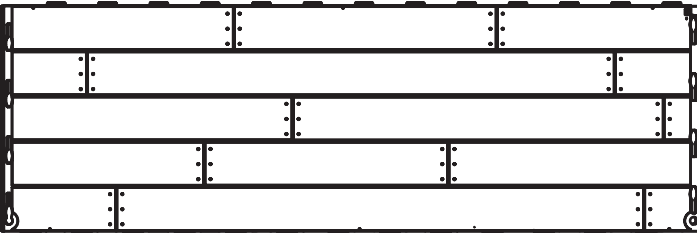

CUD (x2)



### TOOLS REQUIRED / OUTILS REQUIS / INSTRUMENTAL REQUERIDO





## ► SECTION 6 (CONTINUED) / SECTION 6 (SUITE) / SECCIÓN 6 (CONTINUACIÓN)

TOOLS AND HARDWARE REQUIRED / OUTILS ET QUINCAILLERIE REQUIS / INSTRUMENTAL Y HERRAJE REQUERIDOS



- In case of problems with this section, follow the code below to view a video on the assembly in this section.
- En case de problèmes avec cette section, suivre le code en bas pour voir un vidéo sur l'assemblage dans cette section.
- En caso de problemas con esta sección, seguir el código debajo para ver un video sobre el ensamble en esta sección.



<http://go.lifetime.com/10x8fwfloor>



- There is one type of **Inner Floor Panel CUD**. This Panel has two holes that look different but serve the same purpose. They receive the bushings that hold the bottom of the Door Hinge Tubes in place.
- Il y a un type de panneau de plancher **intern** CUD. Ce panneau a deux trous qui semblent différents, bien qu'ils servent le même objectif. Ils tiennent les bagues qui maintiennent les extrémités inférieures des tubes de charnière en place.
- Hay un tipo de panel de piso **interno** CUD. Este panel tiene dos agujeros que parecen diferentes mas sirven el mismo propósito. Ellos reciben los cosquillos que sostienen los extremos inferiores de los tubos de bisagra.

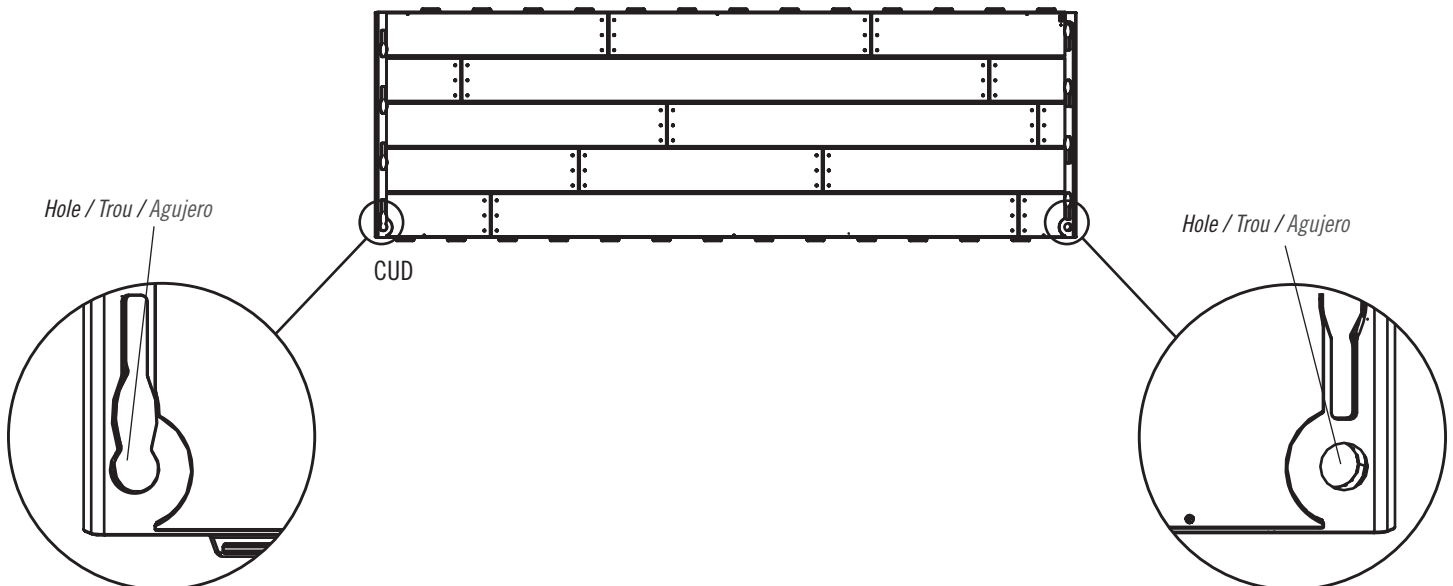

## ► SECTION 6 (CONTINUED) / SECTION 6 (SUITE) / SECCIÓN 6 (CONTINUACIÓN)

TOOLS AND HARDWARE REQUIRED / OUTILS ET QUINCAILLERIE REQUIS / INSTRUMENTAL Y HERRAJE REQUERIDOS



• When the two Inner Floor Panels (CUD) are attached to each other, one of each of these holes should be on the same edge as shown below. **This edge will be the side of the shed where the Doors are installed.**

• En attachant les deux panneaux de plancher internes (CUD), un de chaque trou doit être sur le même bord comme indiqué ci-dessous. **Les deux portes s'installent le long de ce bord.**

• Al ensamblar los dos paneles de piso internos (CUD), uno de cada agujero debe estar en el mismo borde como se muestra abajo. **Se instalarán las dos puertas a lo largo de este borde.**

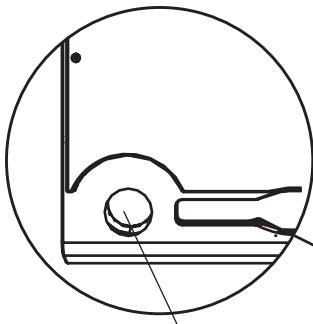

Hole / Trou / Agujero

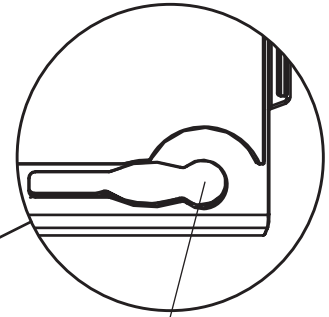
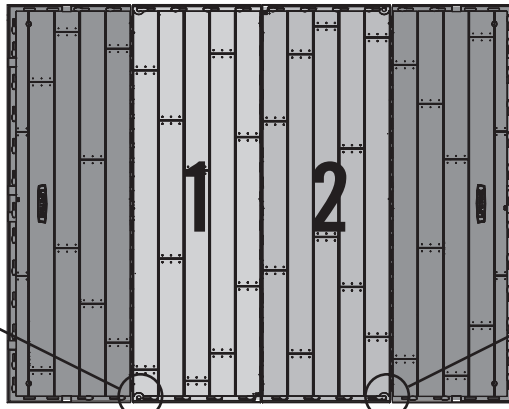

Hole / Trou / Agujero

### 6.1

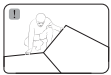

• Hold an **Inner Floor Panel (CUD)** at an angle and slide the tabs along the edge underneath an **Outer Floor Panel (CUW)**. The tabs interlock. Lay Panel down flat.

• Poser un **panneau de plancher intérieur (CUD)** à un angle et glissez les languettes le long du bord au-dessus du **panneau de plancher extérieur (CUW)**. Les languettes s'enclenchent les uns les autres. Étendre-le par terre.

• Colocar un **panel de piso interior (CUD)** a un ángulo y deslice las lengüetas a lo largo del borde debajo el **panel de piso exterior (CUW)**. Las lengüetas se entrelazan las unas con las otras. Aplanarlo.

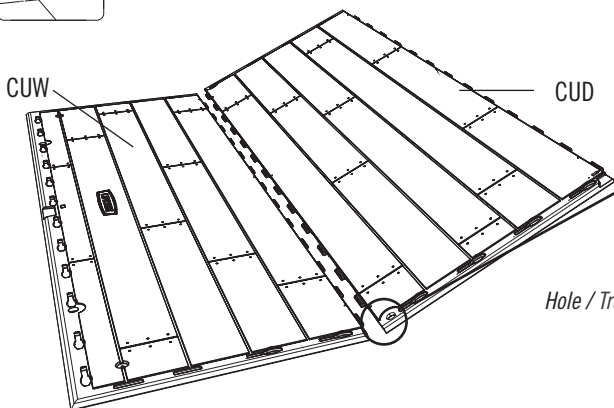

Hole / Trou / Agujero

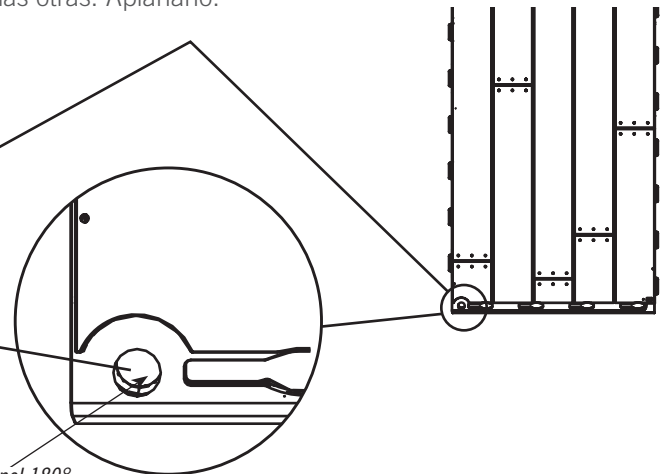

**Note:** If this hole is not at this corner, turn the Panel 180°.  
**Remarque :** Si ce trou n'est pas ici, tourner le panneau 180°.  
**Nota:** Si este agujero no está aquí, girar el panel 180°.

## ► SECTION 6 (CONTINUED) / SECTION 6 (SUITE) / SECCIÓN 6 (CONTINUACIÓN)

TOOLS AND HARDWARE REQUIRED / OUTILS ET QUINCAILLERIE REQUIS / INSTRUMENTAL Y HERRAJE REQUERIDOS



### 6.2

- Repeat the previous step.
- Répéter l'étape précédente.
- Repetir el paso anterior.

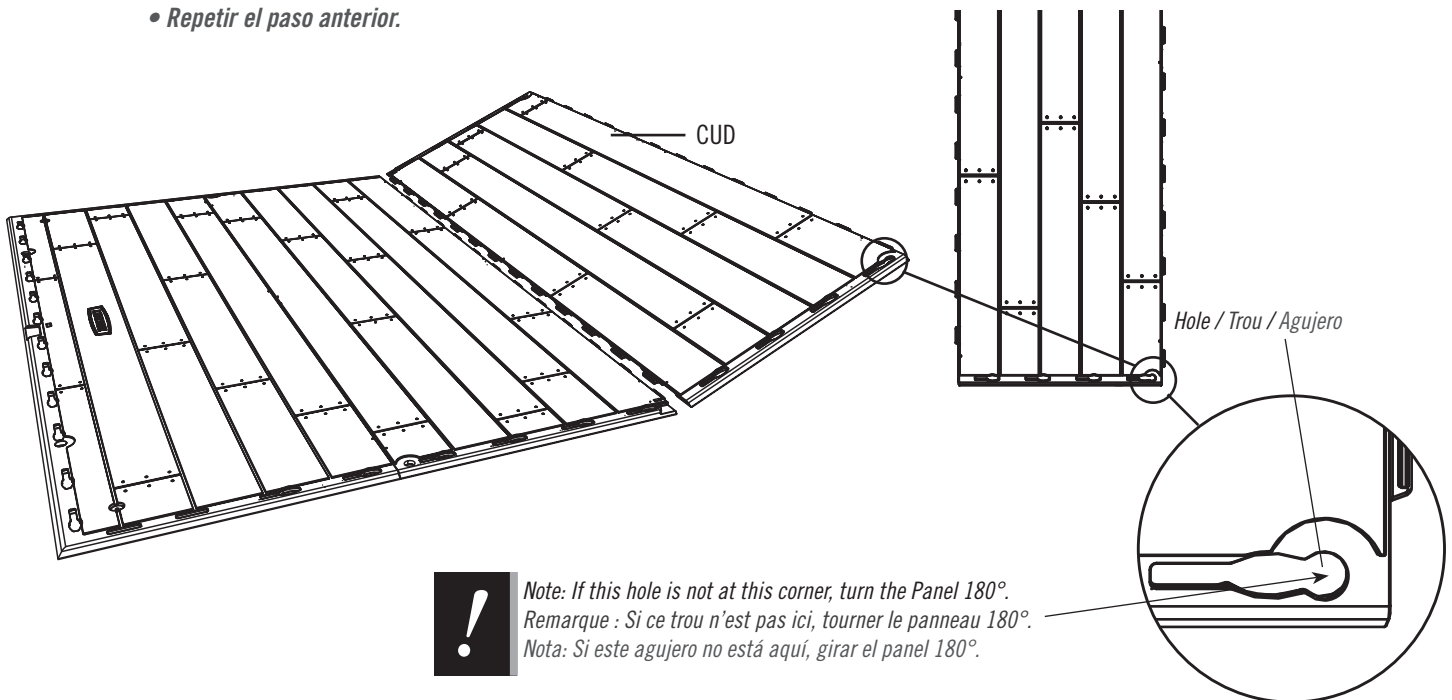

### 6.3

- Attach an **Outer Floor Panel (CUW)** to the Inner Floor Panel.
- Attacher un autre **panneau de plancher intérieur (CUW)** au panneau de plancher intérieur.
- Fijar otro **panel de piso exterior (CUW)** al panel de piso interior.

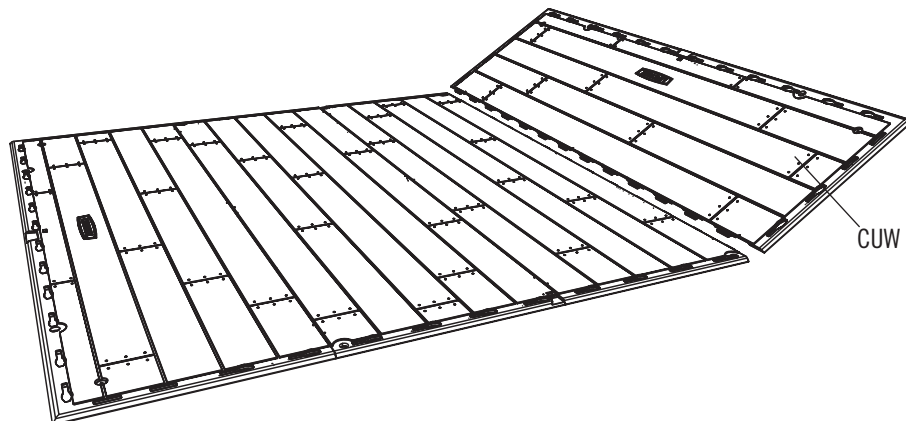

## ► SECTION 6 (CONTINUED) / SECTION 6 (SUITE) / SECCIÓN 6 (CONTINUACIÓN)

TOOLS AND HARDWARE REQUIRED / OUTILS ET QUINCAILLERIE REQUIS / INSTRUMENTAL Y HERRAJE REQUERIDOS

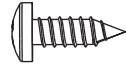

BQC (x18)

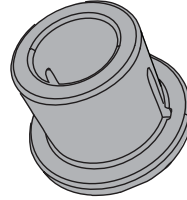

AHO (x2)

### 6.4

- Insert **Bushings (AHO)** through the holes in the Floor. The Doors will be installed here later.
- Insérer les **bagues (AHO)** à travers les trous dans le plancher. Les portes s'installaran ici plus tarde.
- Insertar los **casquillos (AHO)** a través de los agujeros en el piso. Se instalarán las puertas aquí más tarde.

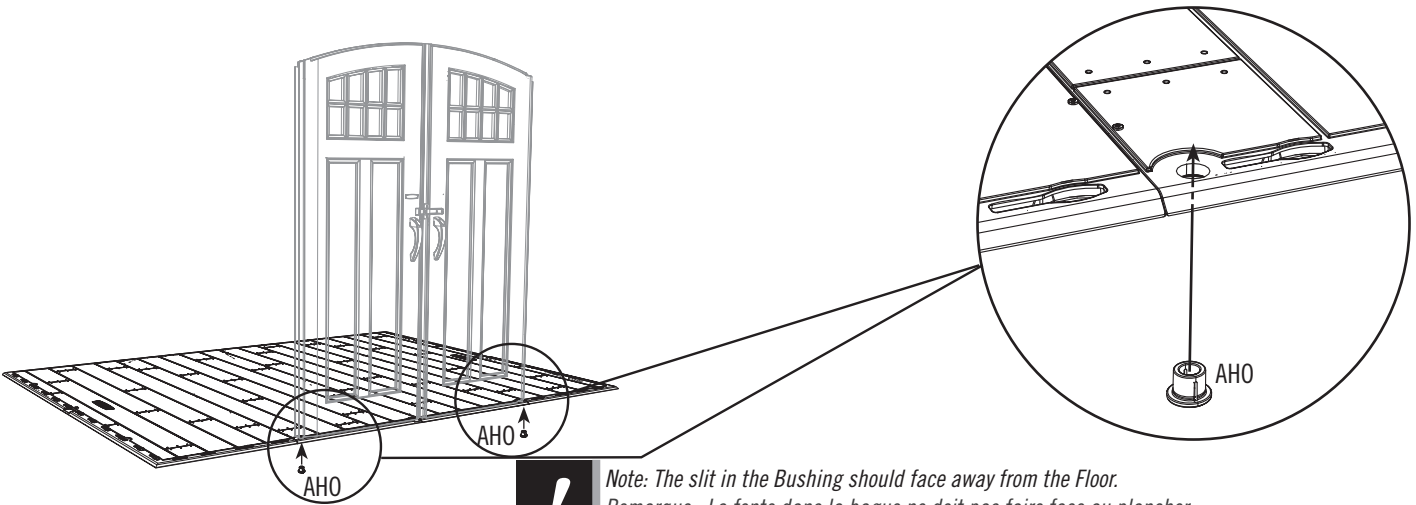

*Note: The slit in the Bushing should face away from the Floor.  
Remarque : La fente dans la bague ne doit pas faire face au plancher.  
Nota: La rendija en el casquillo debe quedar en posición opuesta del piso.*

### 6.5

- Insert the **Screws (BQC)** through the divots in the Floor Panels and into the tabs of the adjacent Floor Panels. (The divots are near the seams of the Floor Panels.)
- Insérer les **vis (BQC)** à travers les marques dans les panneaux de plancher et dans les languettes du panneaux de plancher contigu. (Les marques se trouvent près des jonctions des panneaux de plancher.)
- Insertar los **tornillos (BQC)** a través de las marcas en los paneles de piso y dentro de las lengüetas des los paneles de piso adyacentes. (Se encuentran las marcas cerca de las juntas de los paneles de piso.)

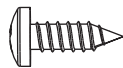

BQC

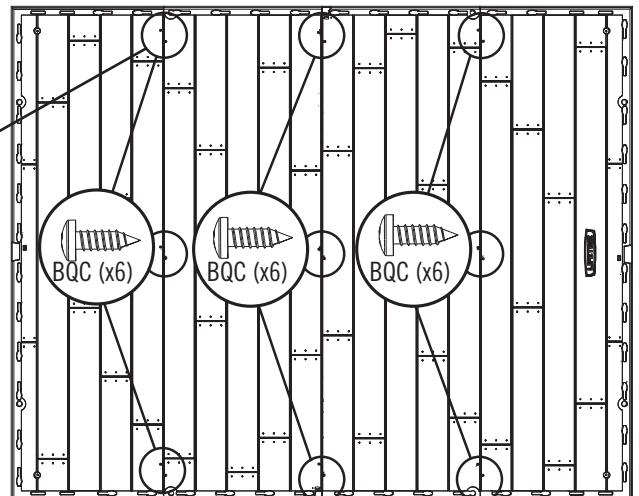
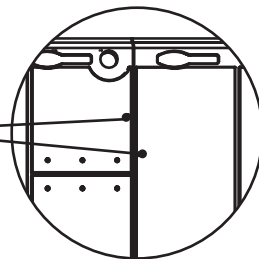

*Note: These Screws do not anchor the Floor; they only hold the Panels together.  
Remarque : Ces vis n'ancrent pas le plancher; ils ne servent que pour attacher les panneaux les uns avec les autres.  
Nota: Estos tornillos no anclan el piso; sirven sólo para sujetar los paneles los unos con los otros.*

# 7

## WALL ASSEMBLY / ASSEMBLAGE DES MURS / ENSAMBLE DE LOS MUROS



### HARDWARE REQUIRED / QUINCAILLERIE REQUISE / HERRAJE REQUERIDO

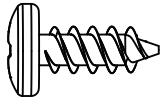

ADZ (x130)



### PARTS REQUIRED / PIÈCES REQUISES / PIEZAS REQUERIDAS

*Metal Parts / Pièces en métal / Piezas de metal*

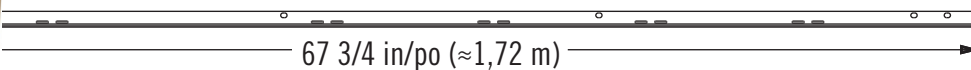

AFM (x9)

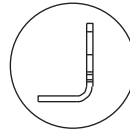

*Plastic Parts / Pièces en plastique / Piezas de plástico*

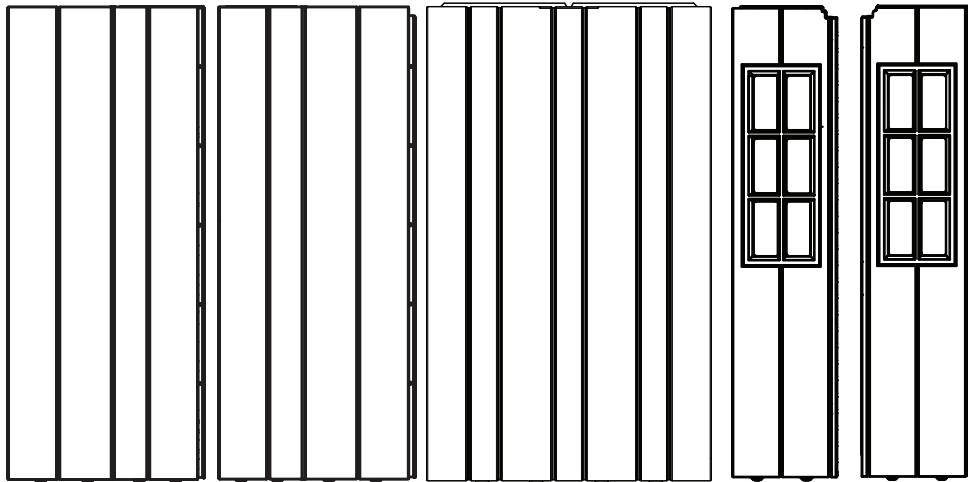

AGL (x2)

AGW (x2)

AHD (x7)

BDH (x1)

BDI (x1)



EPI (x2)



BDV (x2)



AIW (x1)



### TOOLS REQUIRED (NOT INCLUDED—UNLESS INDICATED OTHERWISE) / OUTILS REQUIS (NON INCLUS — SAUF INDICATION CONTRAIRE) / INSTRUMENTAL REQUERIDO (NO INCLUIDO, SALVO INDICACIÓN CONTRARIA)

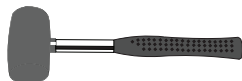

## ► SECTION 7 (CONTINUED) / SECTION 7 (SUITE) / SECCIÓN 7 (CONTINUACIÓN)

TOOLS AND HARDWARE REQUIRED / OUTILS ET QUINCAILLERIE REQUIS / INSTRUMENTAL Y HERRAJE REQUERIDOS

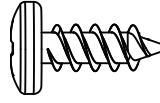

ADZ (x28)

### 7.1

- Insert a **Wall Channel (AFM)** into the groove just to the left notch of the seven (7) **Wall Panels (AHD)** as shown. Secure with four (4) **Screws (ADZ)** for each one. **The top hole is for manufacturing purposes only.**
- Insérer un **support mural (AFM)** dans la rainure juste à gauche de l'encoche dans les sept (7) **panneaux muraux (AHD)** comme illustré. Les fixer à l'aide de quatre (4) **vis (ADZ)** chacun. **Le trou supérieur est pour les fins de fabrication seulement.**
- Insertar un **soporte mural (AFM)** en la ranura apenas a la izquierda de la muesca en los siete (7) **paneles murales (AHD)** como se muestra. Fijarlos usando cuatro (4) **tornillos (ADZ)** cada uno. **El agujero superior sirve sólo para los fines de fabricación.**

- The two holes go at the top.
- Les deux trous vont en haut.
- Los dos agujeros van hacia arriba.



- Notch
- Encoche
- Muesca

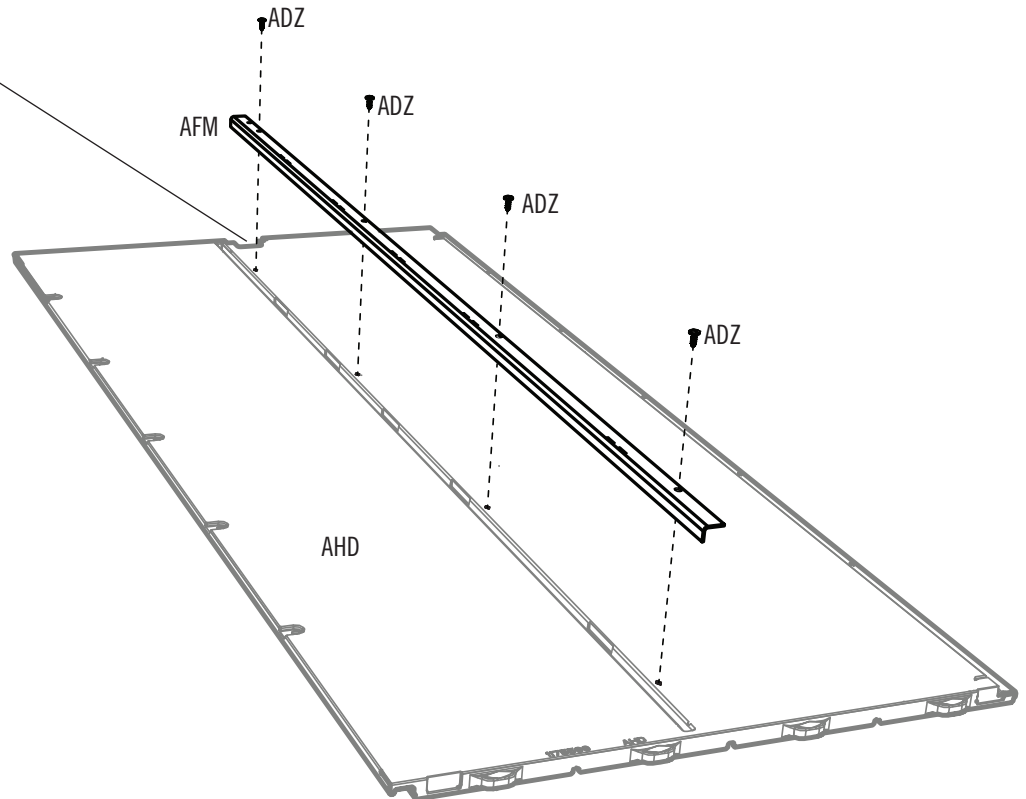

x7

## ► SECTION 7 (CONTINUED) / SECTION 7 (SUITE) / SECCIÓN 7 (CONTINUACIÓN)

TOOLS AND HARDWARE REQUIRED / OUTILS ET QUINCAILLERIE REQUIS / INSTRUMENTAL Y HERRAJE REQUERIDOS

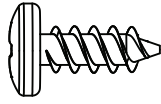

ADZ (x8)

### 7.2

• Insert a **Wall Channel (AFM)** into the first groove on the back of the **Right Window Wall Panel (BDI)** as shown. Secure with four (4) **Screws (ADZ)**.

• Insérer un **support mural (AFM)** dans la première rainure du **panneau mural droit à fenêtre (BDI)** comme illustré. Fixer-le à l'aide de quatre (4) **vis (ADZ)**.

• Insertar un **soporte mural (AFM)** en la primera ranura del **panel mural derecho para la ventana (BDI)** como se muestra. Fijarlo usando cuatro (4) **tornillos (ADZ)**.

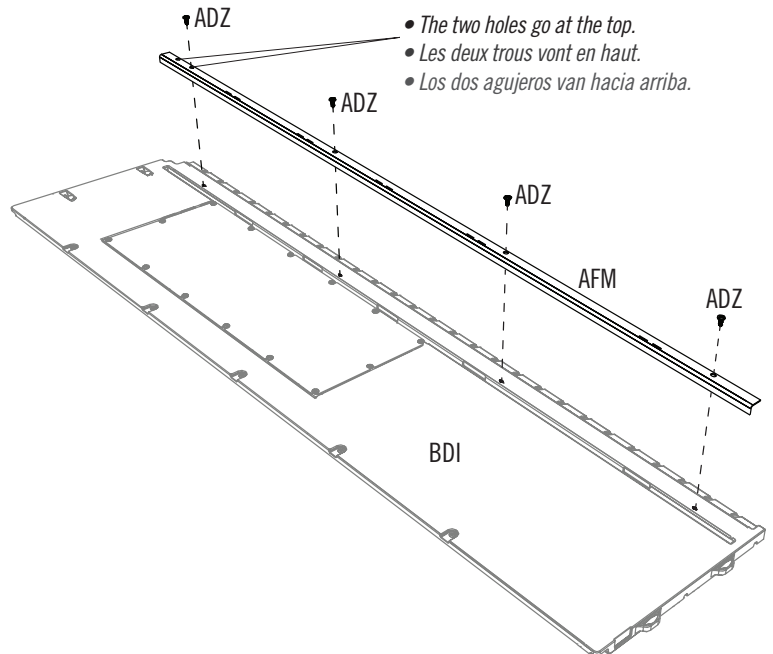

### 7.3

• Insert a **Wall Channel (AFM)** into the first groove on the back of the **Left Window Wall Panel (BDH)** as shown. Secure with four (4) **Screws (ADZ)**.

• Insérer un **support mural (AFM)** dans la première rainure du **panneau mural gauche à fenêtre (BDH)** comme illustré. Fixer-le à l'aide de quatre (4) **vis (ADZ)**.

• Insertar un **soporte mural (AFM)** en la primera ranura del **panel mural izquierdo para la ventana (BDH)** como se muestra. Fijarlo usando cuatro (4) **tornillos (ADZ)**.

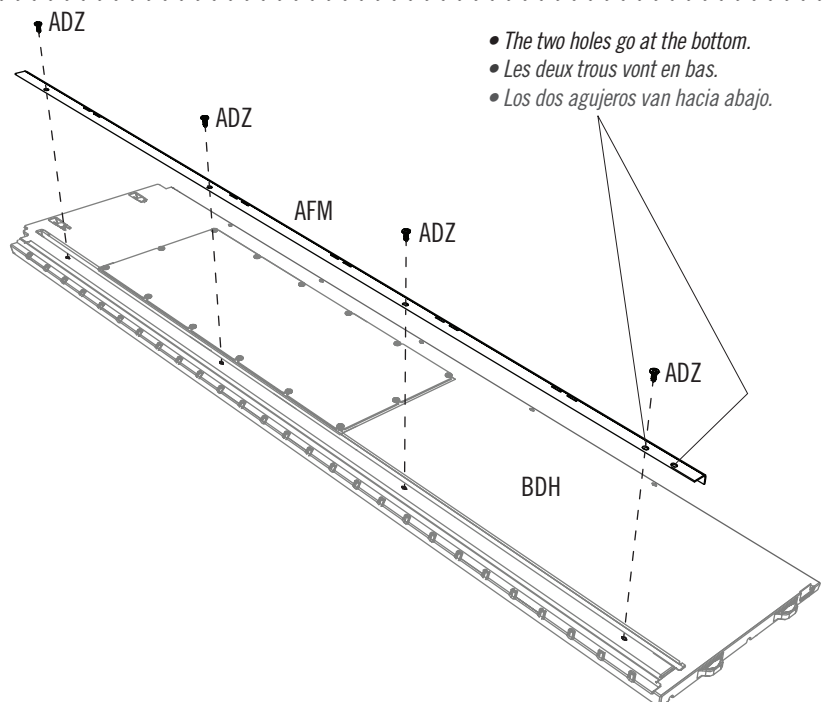





# PARTS IDENTIFIER / IDENTIFICATEUR DE PIÈCES / IDENTIFICADOR DE PIEZAS

CONTENTS OF BOX 1 / CONTENU DE LA BOÎTE 1 / CONTENIDO DE LA CAJA 1

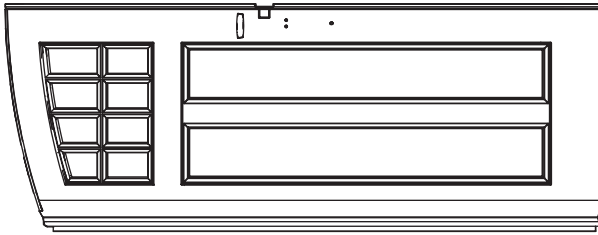

BDJ (x1)

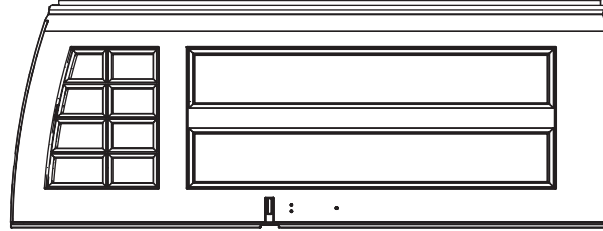

BDK (x1)

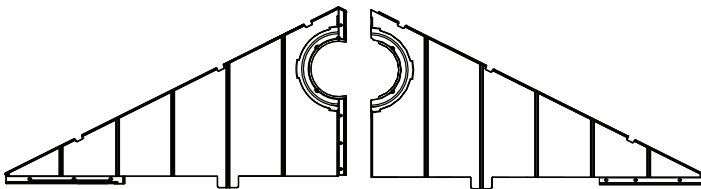

AGI (x2)

AGH (x2)

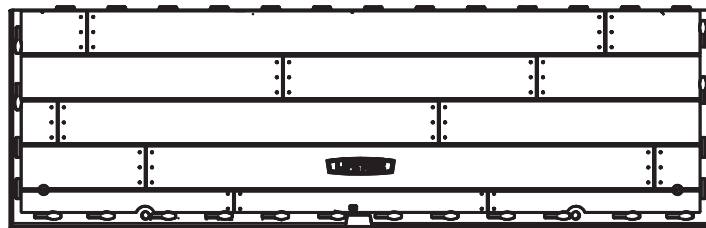

CUW (x2)

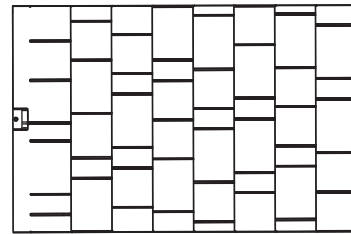

AGQ (x6)

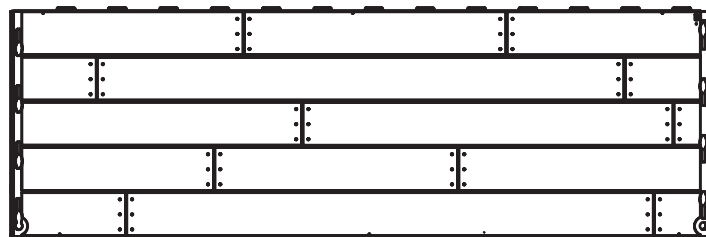

CUD (x2)

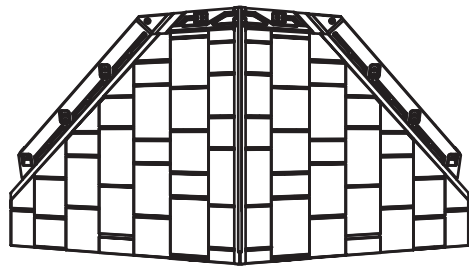

DRA (x1)

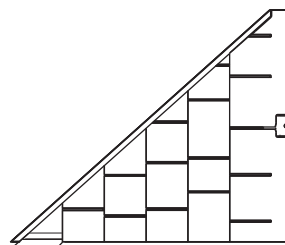

BDR (x1)

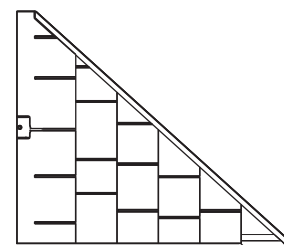

BDS (x1)

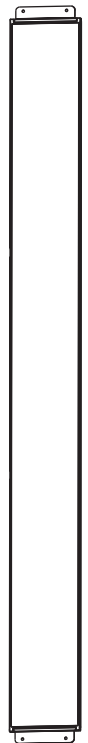

AFV (x2)

*Remove This Section / Enlever cette section / Retirar esta sección*



# PARTS IDENTIFIER / IDENTIFICATEUR DE PIÈCES / IDENTIFICADOR DE PIEZAS

METAL PARTS KIT 1 / KIT PIÈCES EN MÉTAL 1 / KIT DE PIEZAS DE METAL 1

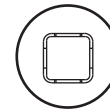
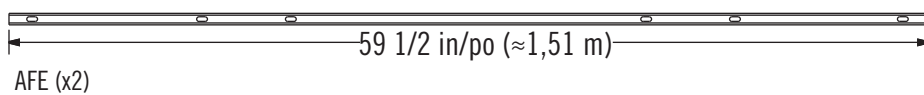
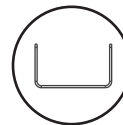
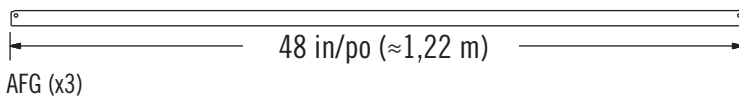
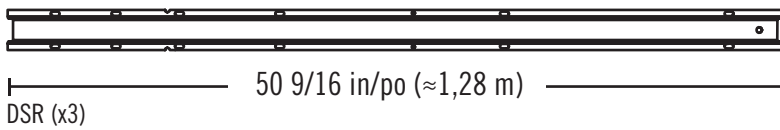
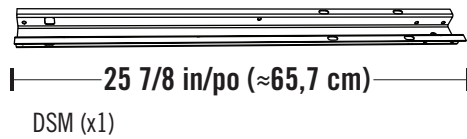
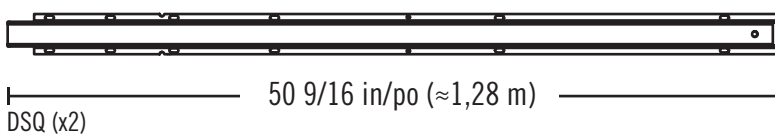
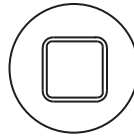
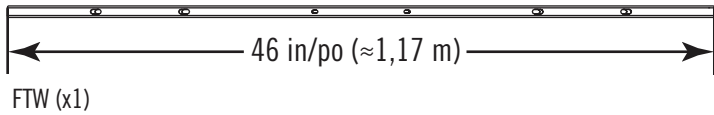
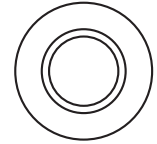
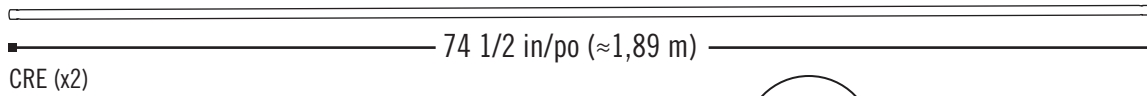

Remove This Section / Enlever cette section / Retirar esta sección

METAL PARTS KIT 2 / KIT PIÈCES EN MÉTAL 2 / KIT DE PIEZAS DE METAL 2

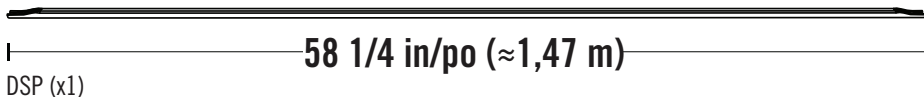
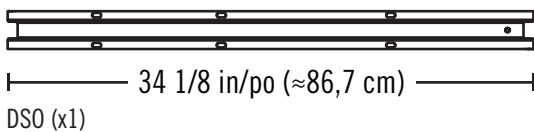
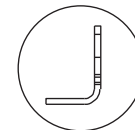
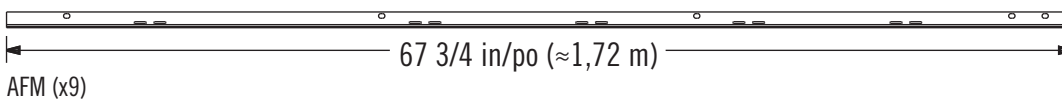
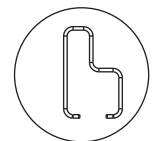
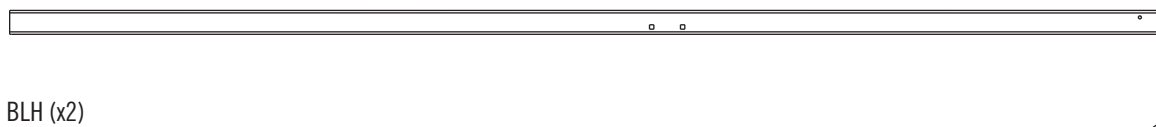



# PARTS IDENTIFIER / IDENTIFICATEUR DE PIÈCES / IDENTIFICADOR DE PIEZAS

CONTENTS OF BOX 2 / CONTENU DE LA BOÎTE 2 / CONTENIDO DE LA CAJA 2

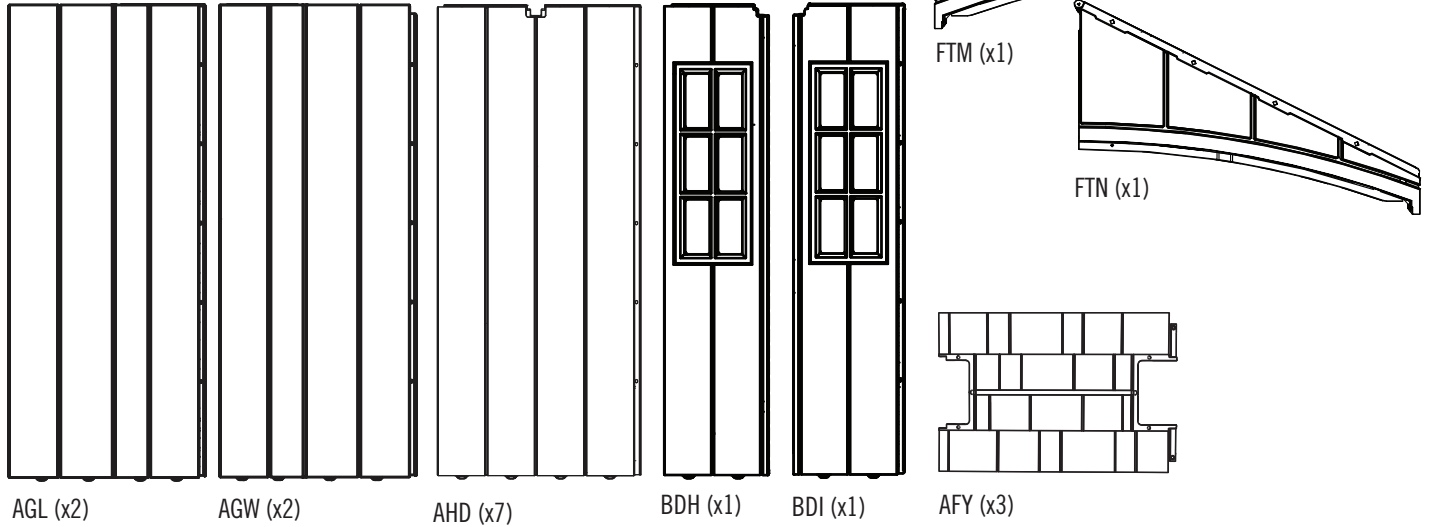

CONTENTS OF SMALL PARTS KIT / CONTENU DU KIT PETITES PIÈCES / CONTENIDO DEL KIT DE PIEZAS PEQUEÑAS

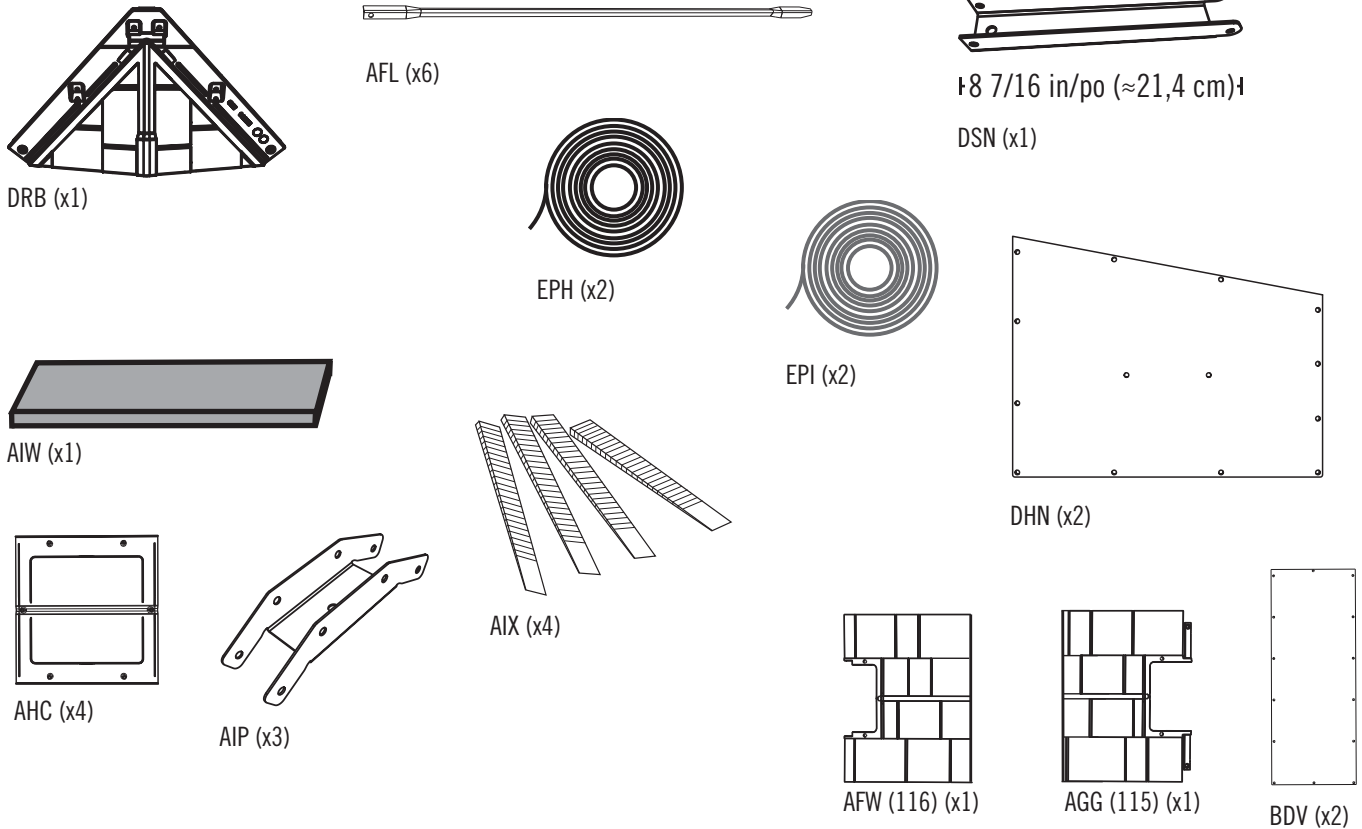

Remove This Section / Enlever cette section / Retirar esta sección



## PARTS IDENTIFIER / IDENTIFICATEUR DE PIÈCES / IDENTIFICADOR DE PIEZAS

CONTENTS OF BOX 2 / CONTENU DE LA BOÎTE 2 / CONTENIDO DE LA CAJA 2

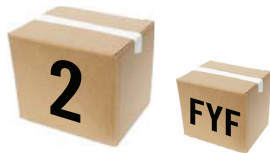

HARDWARE BAGS / SACS DE QUINCAILLERIE / BOLSAS DE HERRAJE



*Remove This Section / Enlever cette section / Retirar esta sección*

## ► SECTION 7 (CONTINUED) / SECTION 7 (SUITE) / SECCIÓN 7 (CONTINUACIÓN)

TOOLS AND HARDWARE REQUIRED / OUTILS ET QUINCAILLERIE REQUIS / INSTRUMENTAL Y HERRAJE REQUERIDOS



### 7.4

- There is a narrow groove (illustrated in black) running along the outside of the window on the back of each **Narrow Window Wall Panel (BDH & BDI)**. Starting at the top, left corner of the groove in one of the Narrow Window Wall Panels, lay a 1/8" (3,2 mm) bead of the **Tan Butyl Tape (EPI)** into the groove. **Do not worry about getting the bead completely into the groove just yet—simply lay the bead over the groove. Do not press the bead into the groove.** Work your way downward (1), and curve to go along the bottom (2) of the window. Curve your way upward (3) and then along the top (4) of the window until you're back where you started. **Clip off the excess.**
- Une rainure étroite (illustrée en noir) se trouve le long de l'extérieur de la fenêtre à l'arrière de chaque panneau mural étroit. Partant du coin supérieur gauche de la rainure dans un panneau mural étroit avec fenêtre, étendre une goutte de 1/8 po (3,2 mm) de **ruban de caoutchouc butyl couleur sable (EPI)** dans la rainure. **Ne pas s'inquiéter si la goutte n'est pas complètement dans la rainure en ce moment, ne faire que déposer la goutte sur la rainure.** Ne pas pousser la goutte dans la rainure. Travailler vers le bas (1), et courber pour atteindre le bas (2) de la fenêtre. Courber vers le haut (3), puis le long du haut (4) de la fenêtre jusqu'à revenir au point de départ. **Couper l'excédent.**
- Hay una ranura angosta (ilustrada en negro) bordeando la ventana en la superficie posterior de cada panel mural angosto con ventana. Comenzando desde arriba, en la esquina izquierda de la ranura en un panel, aplicar una línea de 3,2 mm (1/8 in) de **cinta butílica de color cuero (EPI)** en la ranura. **No preocuparse por poner la cinta, mas solamente ponga la cinta sobre la ranura. No presionar la cinta dentro de la ranura.** Seguir hacia abajo (1), y curvarla a lo largo del borde inferior (2) de la ventana. Curvarla hacia arriba (3) y, entonces, a lo largo del borde superior (4) de la ventana hasta estar al punto de partida. **Cortar el exceso.**



EPI (x1)

Groove  
Rainure  
Ranura

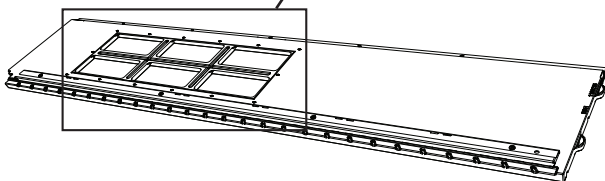
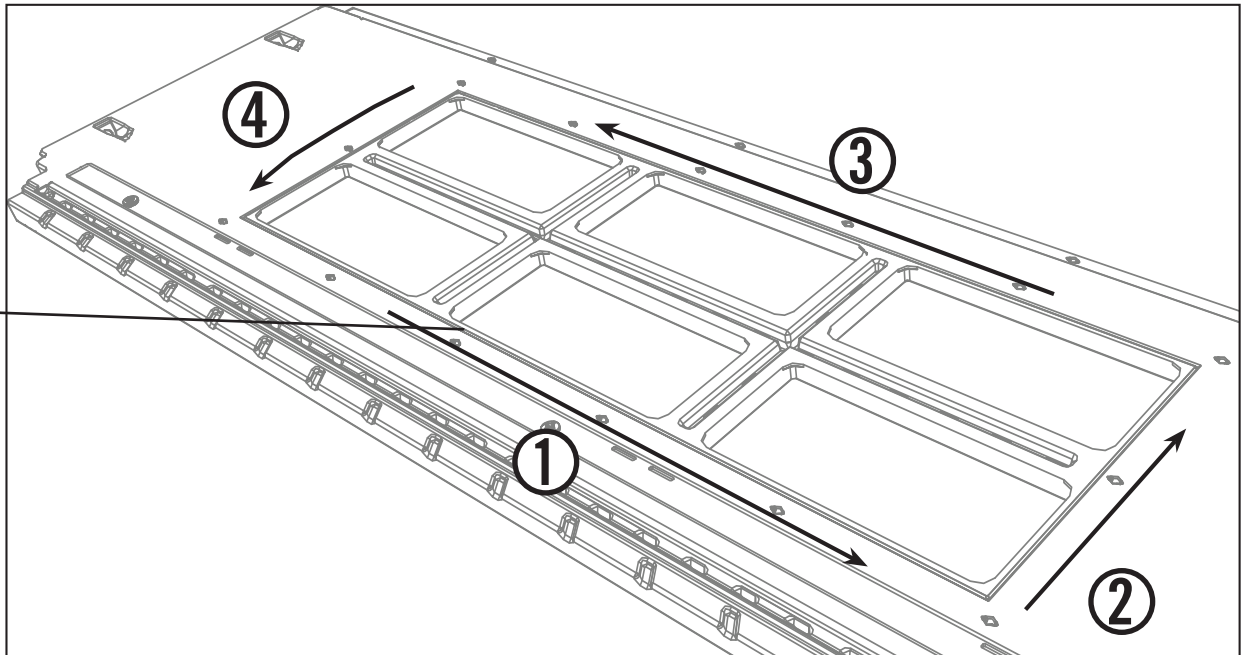

## ► SECTION 7 (CONTINUED) / SECTION 7 (SUITE) / SECCIÓN 7 (CONTINUACIÓN)

TOOLS AND HARDWARE REQUIRED / OUTILS ET QUINCAILLERIE REQUIS / INSTRUMENTAL Y HERRAJE REQUERIDOS

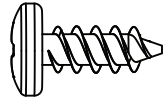

ADZ (x14)

### 7.5

- Peel off the protective backing from both sides of **Window Pane (BDV)**. Align the holes in the Pane with those in the Panel, and gently set a Window Pane down onto the Panel. Secure the Pane to the Panel using fourteen (14) **Screws (ADZ)**. **Repeat steps 7.2–7.3 for the second Narrow Window Wall Panel.**
- Retirer la pellicule protectrice des deux côtés du **carreau (BDV)**. Aligner les trous dans le carreau avec ceux de la porte, et, avec douceur, mettre le carreau sur la porte. Fixer le carreau à la porte en utilisant quatorze (14) **vis (ADZ)**. **Répéter les étapes 7.2 – 7.3 pour le deuxième panneau mural étroit avec fenêtre.**
- Retirar el protector de plástico de las dos caras de una **hoja (BDV)**. Alinear los agujeros en la hoja con los de la puerta, y colocar ligeramente la hoja de ventana en la puerta. Fijar la hoja a la puerta usando catorce (14) **tornillos (ADZ)**. **Repetir los pasos 7.2–7.3 para la segunda panel mural angosto con ventana.**

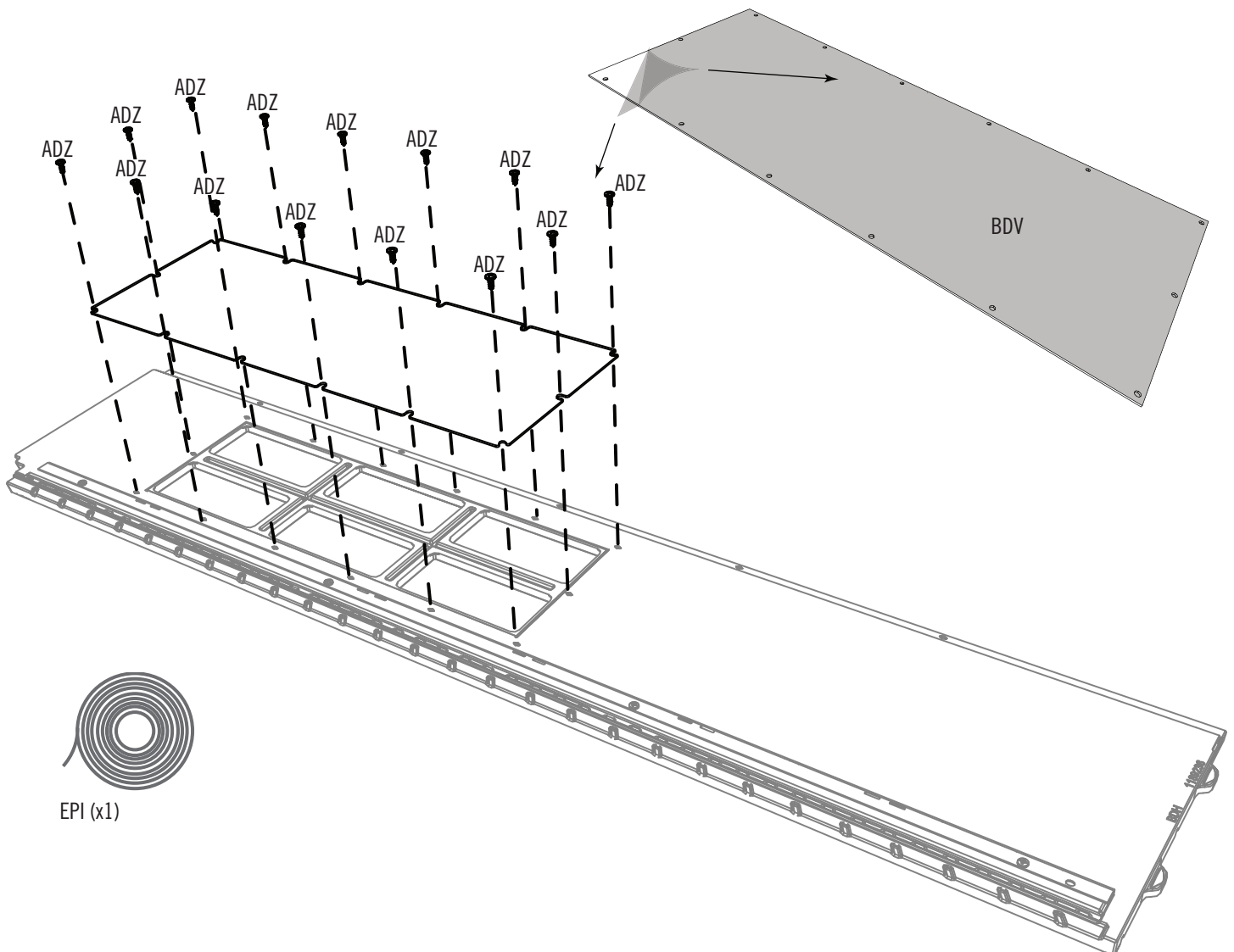

EPI (x1)

## ► SECTION 7 (CONTINUED) / SECTION 7 (SUITE) / SECCIÓN 7 (CONTINUACIÓN)

TOOLS AND HARDWARE REQUIRED / OUTILS ET QUINCAILLERIE REQUIS / INSTRUMENTAL Y HERRAJE REQUERIDOS

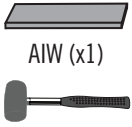

### 7.6



- Insert tabs at the bottom of the **Right Window Wall Panel (BDI)** into the third and fourth slots from the front, right corner of the Floor.
- Insérer les languettes au bord inférieur du **panneau mural droit pour la fenêtre (BDI)** dans les troisième et quatrième rainures du coin droit du plancher.
- Insertar las lengüetas al borde inferior del **panel mural derecho para la ventana (BDI)** en las tercera y quarta ranuras de la esquina derecha del piso.

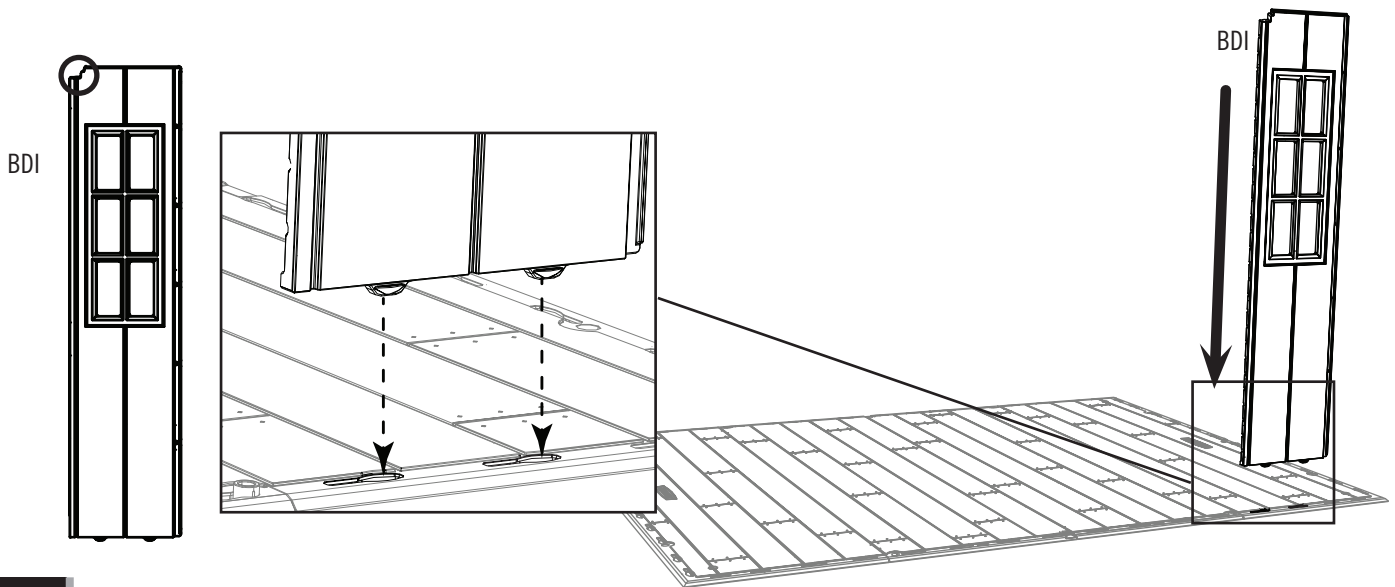

### 7.7

- Slide the Panel to the left.
- Faire glisser le panneau à gauche.
- Deslizar el panel a la izquierda.



*Nota: You may need to use a rubber mallet and the flat side of the Wood Block (AIW) to gently tap the Wall Panel into place.*

*Remarque : Si besoin, utiliser un maillet en caoutchouc et le côté plat du bloc en bois (AIW) pour couper doucement en place le panneau mural.*

*Nota: Si es necesario, usar un mazo de goma y el lado plano del bloque de madera (AIW) para golpear suavemente en su lugar el panel mural.*

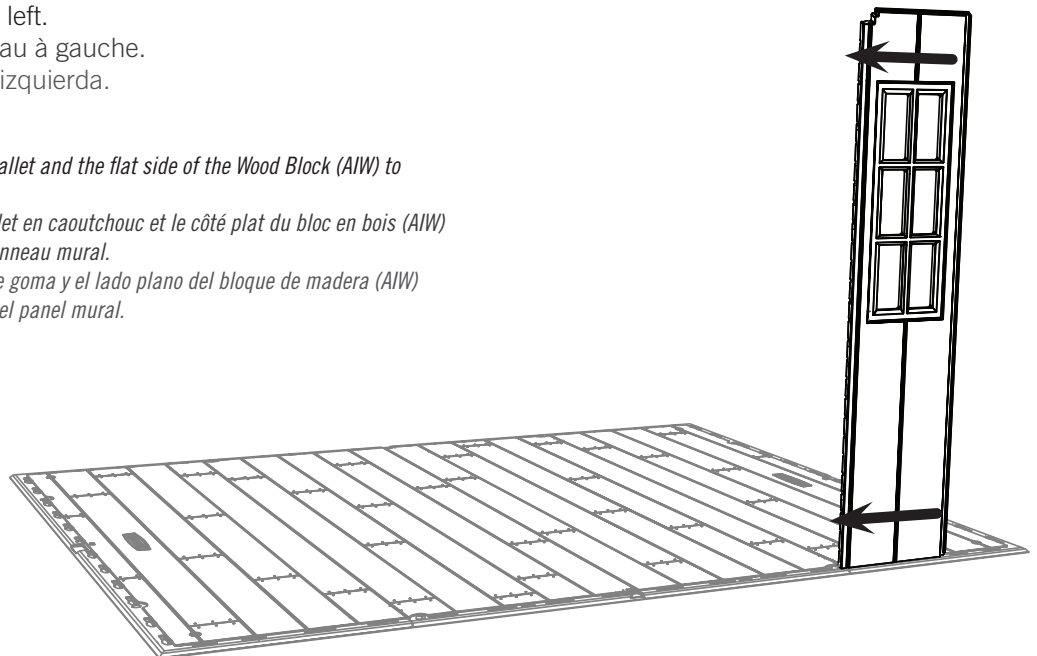



## ► SECTION 7 (CONTINUED) / SECTION 7 (SUITE) / SECCIÓN 7 (CONTINUACIÓN)

TOOLS AND HARDWARE REQUIRED / OUTILS ET QUINCAILLERIE REQUIS / INSTRUMENTAL Y HERRAJE REQUERIDOS



AIW (x1)



### 7.8

- Insert tabs at the bottom of the **Corner Panel (AGW)** into the first two slots along the right edge of the Floor, and slide the Panel toward the front of the Floor.
- Insérer les languettes au bord inférieur du **panneau angulaire (AGW)** dans les premières rainures le long du bord droit du plancher, et faire glisser le panneau vers la partie avant de l'abri.
- Insertar las lengüetas al borde inferior del **panel angular (AGW)** en las primeras dos ranuras a lo largo del borde derecho del piso, y deslizar el panel hacia la parte delantera de la caseta.

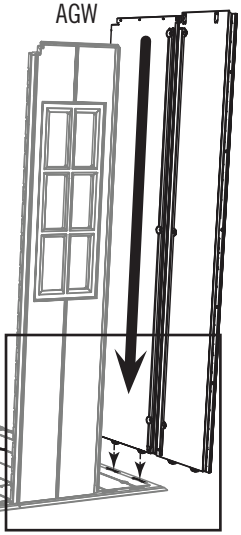
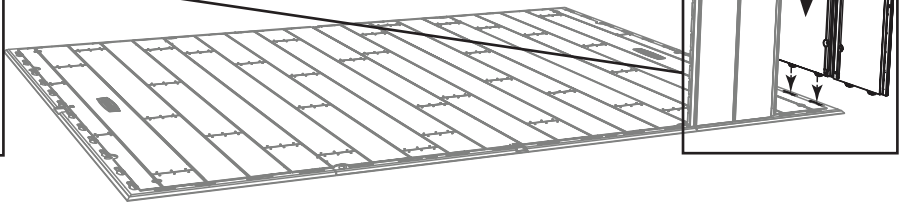
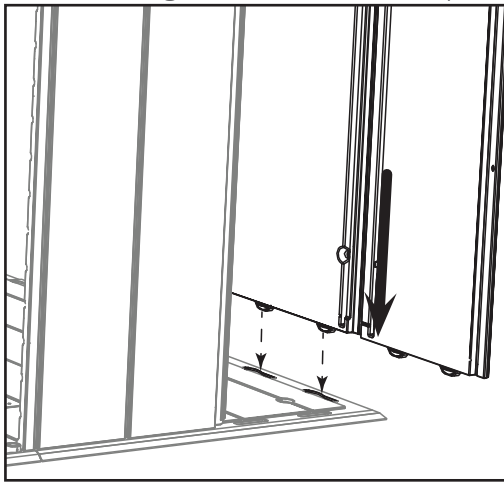

### 7.9

- Bend the Corner Panel as shown, and pull down to snap the tabs into the first two slots from the right corner of the Floor. Place the **Wood Block (AIW)** underneath the Floor and directly underneath the tab being inserted to help with insertion.
- Plier le panneau angulaire comme indiqué, tirer le panneau vers le bas, et insérer les languettes dans les premières deux encoches du coin vant droit. Pour aider avec l'insertion, mettre le **bloc en bois (AIW)** sous le plancher et directement sous la languette à insérer.
- Desplegar el panel angular como se muestra, tirar para abajo el panel, e insertar las lengüetas en las dos primeras muescas de la esquina delantera derecha. Para ayudar con la inserción, colocar el **bloque de madera (AIW)** debajo el piso y directamente debajo de la lengüeta a insertar.

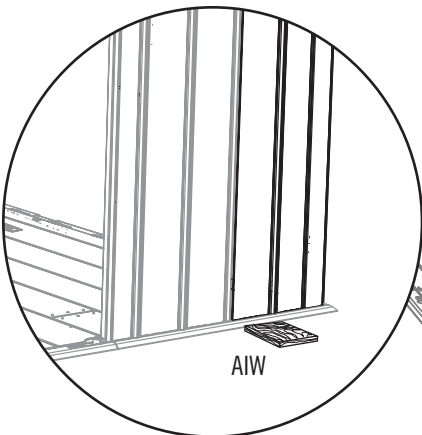

AIW

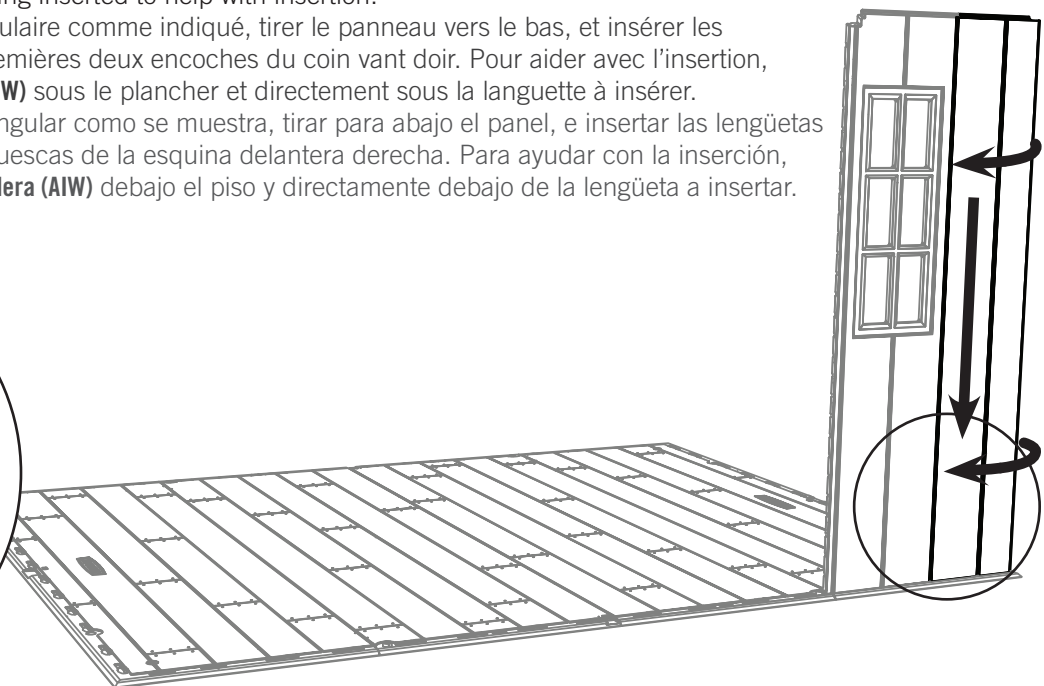

## ► SECTION 7 (CONTINUED) / SECTION 7 (SUITE) / SECCIÓN 7 (CONTINUACIÓN)

TOOLS AND HARDWARE REQUIRED / OUTILS ET QUINCAILLERIE REQUIS / INSTRUMENTAL Y HERRAJE REQUERIDOS



AIW (x1)

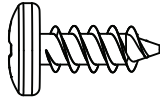

ADZ (x15)

### 7.10

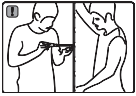

- Secure the two Panels using five (5) **Screws (ADZ)**.
- Fixer bien les deux panneaux à l'aide de cinq (5) **vis (ADZ)**.
- Fijar los dos paneles usando cinco (5) **tornillos (ADZ)**.

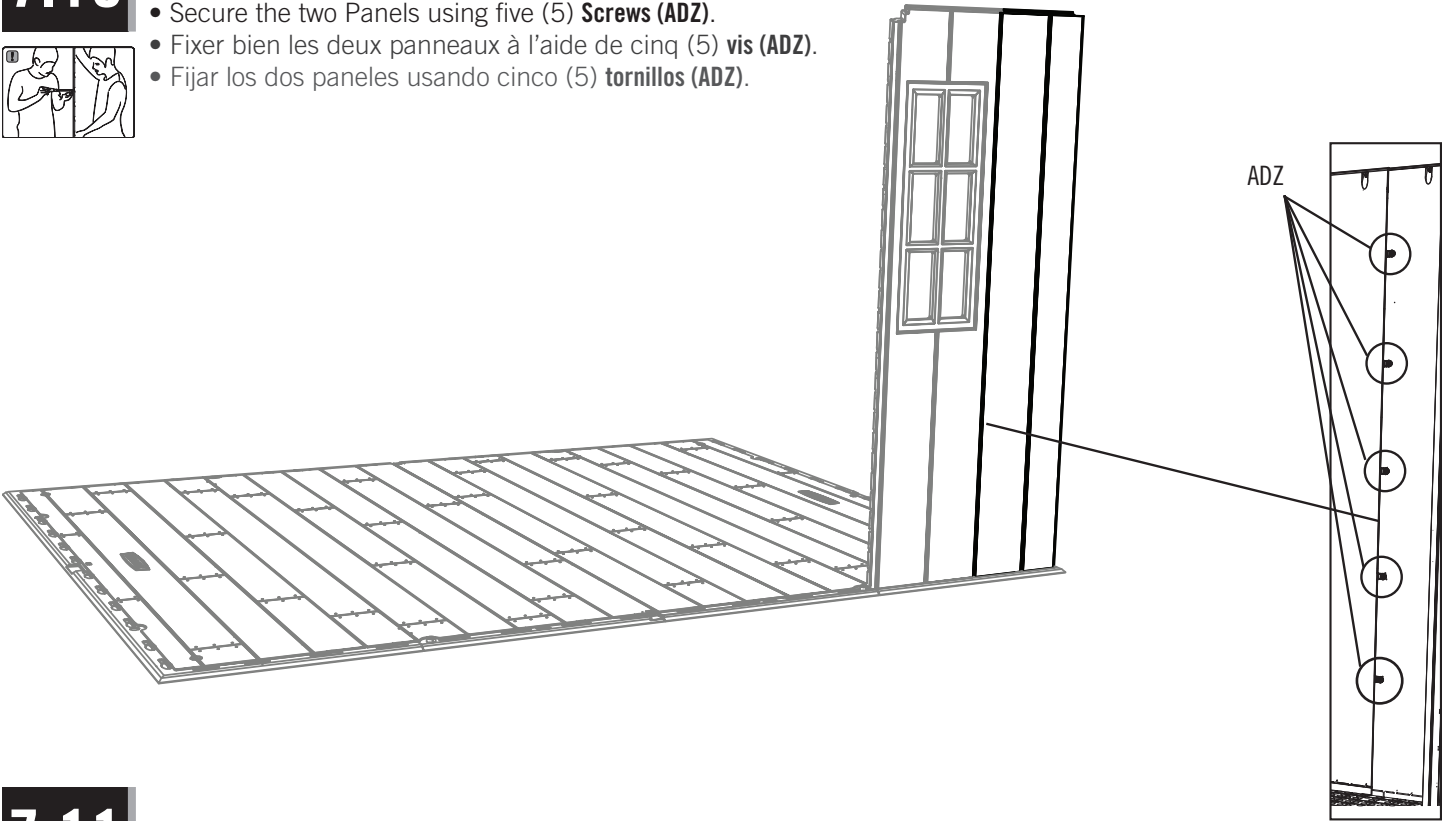

### 7.11



- Insert two (2) **Wall Panels (AHD)**, and secure using five (5) **Screws (ADZ)** each.
- Insérer deux (2) **panneaux muraux (AHD)**, et attacher-les l'un à l'autre à l'aide de cinq (5) **vis (ADZ)** chacun.
- Insertar dos (2) **Paneles de pared (AHD)**, y sujetarlos usando cinco (5) **tornillos (ADZ)** cada uno.

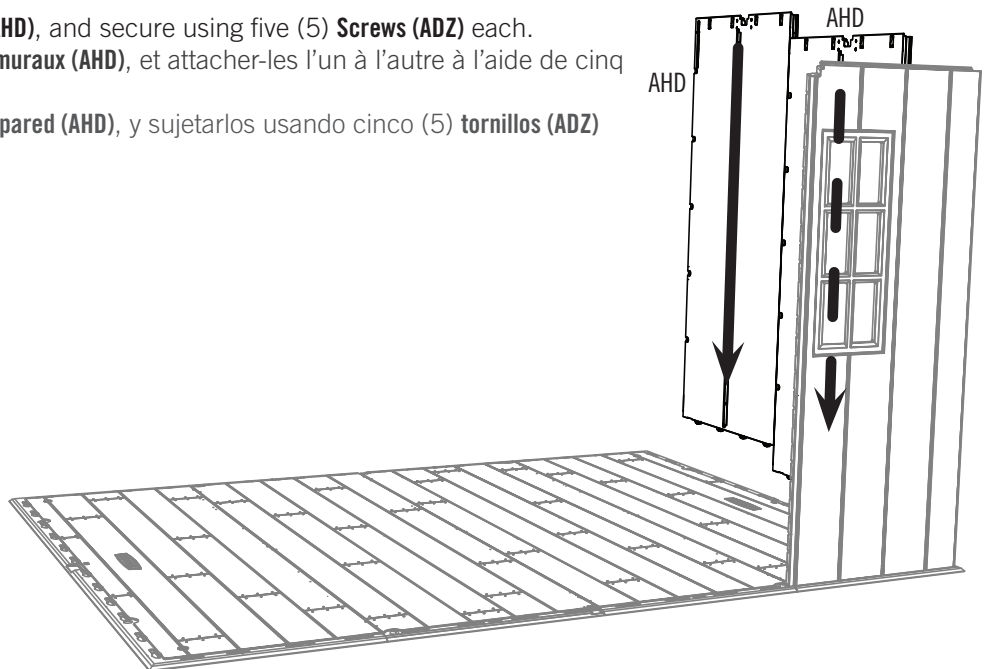

## ► SECTION 7 (CONTINUED) / SECTION 7 (SUITE) / SECCIÓN 7 (CONTINUACIÓN)

TOOLS AND HARDWARE REQUIRED / OUTILS ET QUINCAILLERIE REQUIS / INSTRUMENTAL Y HERRAJE REQUERIDOS



AIW (x1)

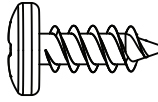

ADZ (x20)

### 7.12

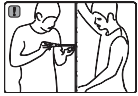

- For the right, rear **Corner Panel (AGL)**, repeat the step done for the right, front Corner Panel.
- Pour le **panneau angulaire (AGL)** arrière droit, répéter les étapes réalisées pour le panneau angulaire avant droit.
- Para el **panel angular (AGL)** trasero derecho, repetir los pasos efectuados para el panel angular delantero derecho.

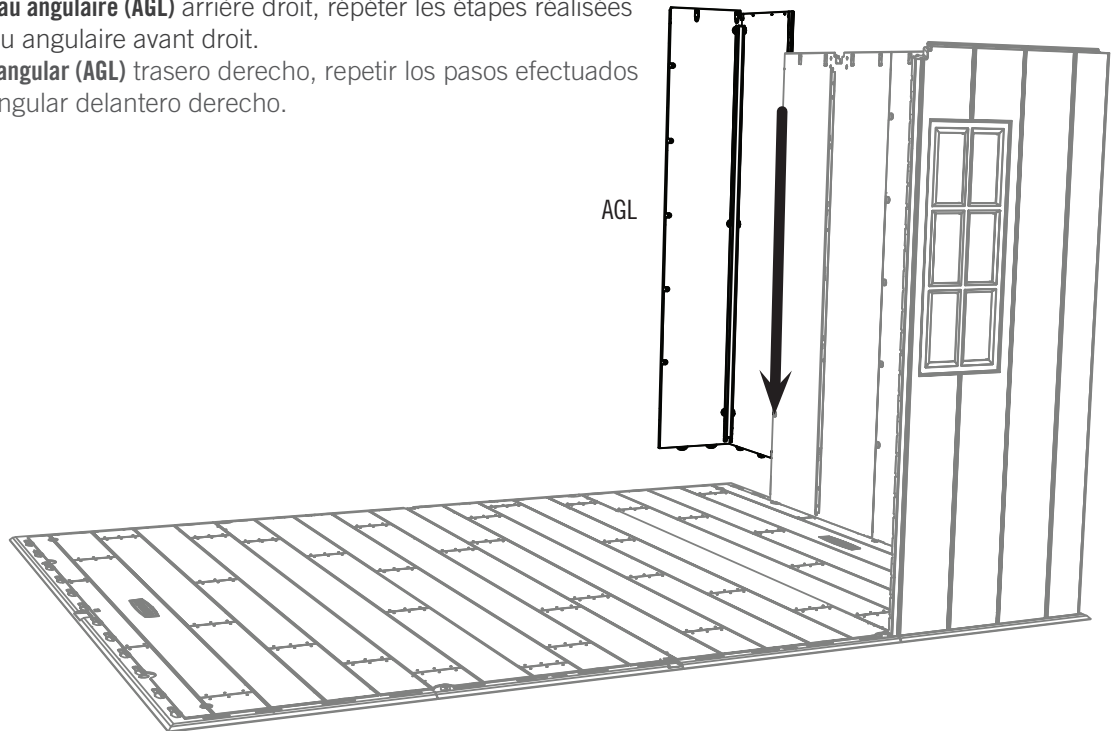

### 7.13

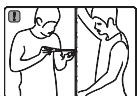

- Insert three (3) **Wall Panels (AHD)** along the rear edge of the Floor, and secure using five (5) **Screws (ADZ)** each.
- Insérer trois (3) **panneaux muraux (AHD)** le long du bord arrière du plancher, et les fixer l'un à l'autre à l'aide de cinq (5) **vis (ADZ)** chacun.
- Insertar tres (3) **paneles de pared (AHD)** a lo largo del borde trasero del piso, y sujetarlos usando cinco (5) **tornillos (ADZ)** cada uno.

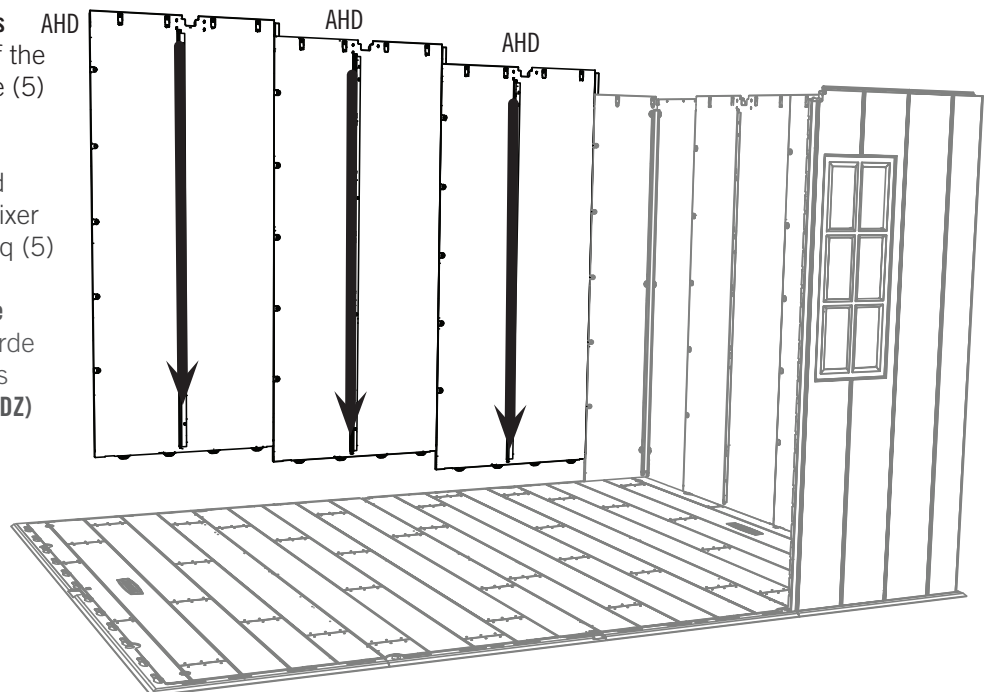

## ► SECTION 7 (CONTINUED) / SECTION 7 (SUITE) / SECCIÓN 7 (CONTINUACIÓN)

TOOLS AND HARDWARE REQUIRED / OUTILS ET QUINCAILLERIE REQUIS / INSTRUMENTAL Y HERRAJE REQUERIDOS



AIW (x1)

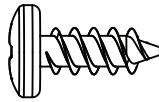

ADZ (x15)

### 7.14

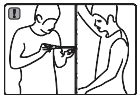

- For the left, rear **Corner Panel (AGW)**, repeat the step you did for the right, front Corner Panel.
- Pour le **panneau angulaire (AGW)** arrière gauche, répéter les étapes réalisées pour le panneau angulaire avant droit.
- Para el **panel angular (AGW)** trasero izquierdo, repetir los pasos efectuados para el panel angular delantero derecho.

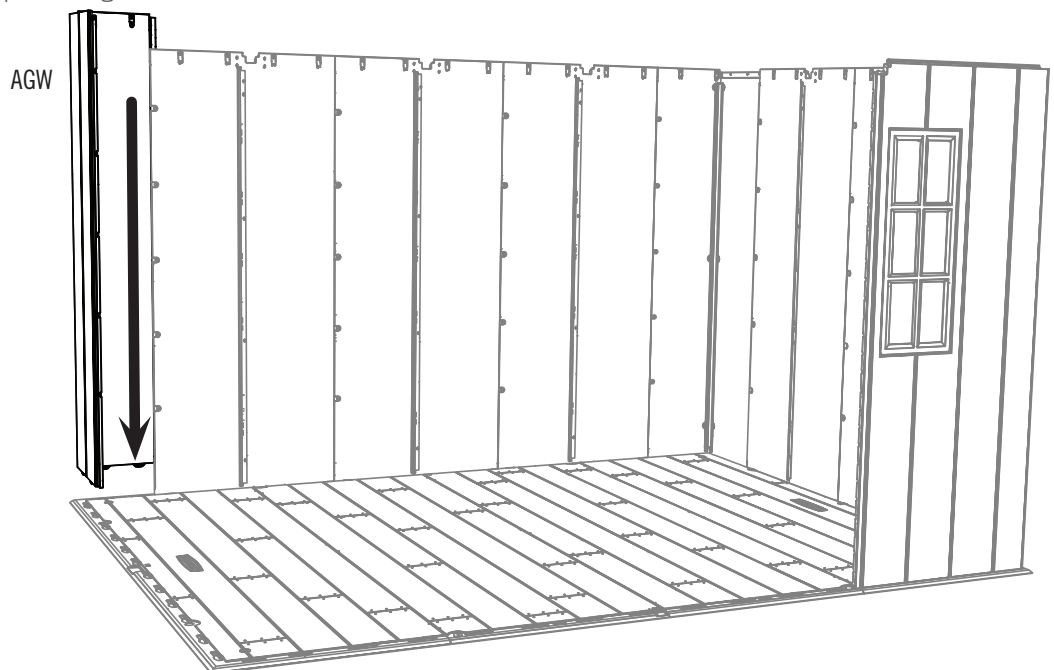

### 7.15

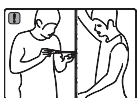

- Insert two (2) **Wall Panels (AHD)**, and secure using five (5) **Screws (ADZ)** each.
- Insérer deux (2) **panneaux muraux (AHD)**, et les fixer l'un à l'autre à l'aide de cinq (5) **vis (ADZ)** chacun.
- Insertar dos (2) **paneles de pared (AHD)**, y fijarlos usando cinco (5) **tornillos (ADZ)** cada uno.

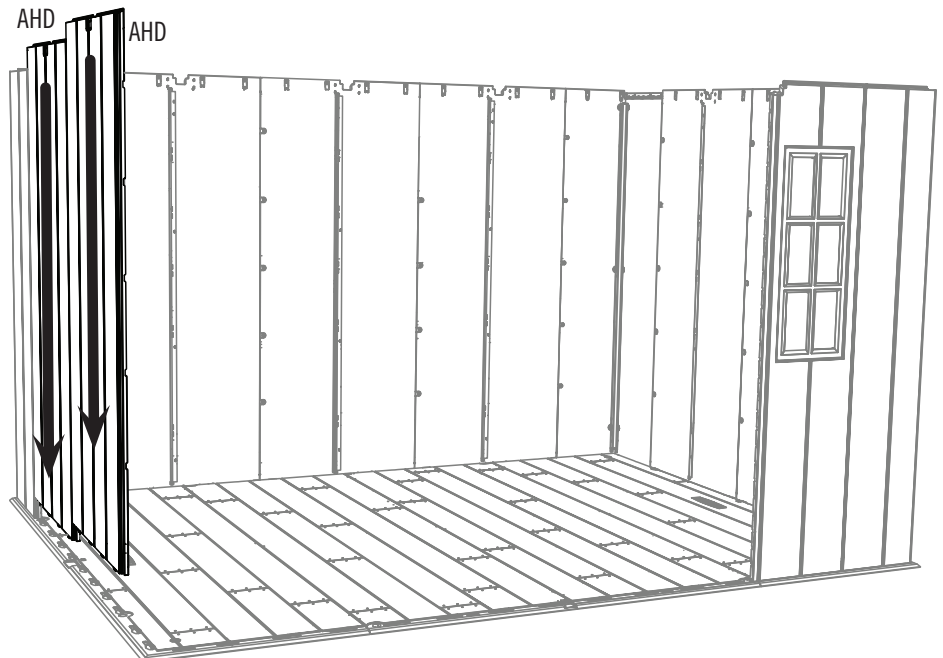

## ► SECTION 7 (CONTINUED) / SECTION 7 (SUITE) / SECCIÓN 7 (CONTINUACIÓN)

TOOLS AND HARDWARE REQUIRED / OUTILS ET QUINCAILLERIE REQUIS / INSTRUMENTAL Y HERRAJE REQUERIDOS



AIW (x1)

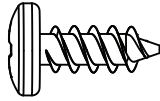

ADZ (x10)

### 7.16

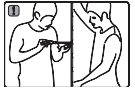

- For the left, front **Corner Panel (AGL)**, repeat the step you did for the right, front Corner Panel.
- Pour le **panneau angulaire (AGL)** avant gauche, répéter les étapes réalisées pour le panneau angulaire avant droit.
- Para el **panel angular (AGL)** delantero izquierdo, repetir los pasos que se efectuados para el panel angular delantero derecho.

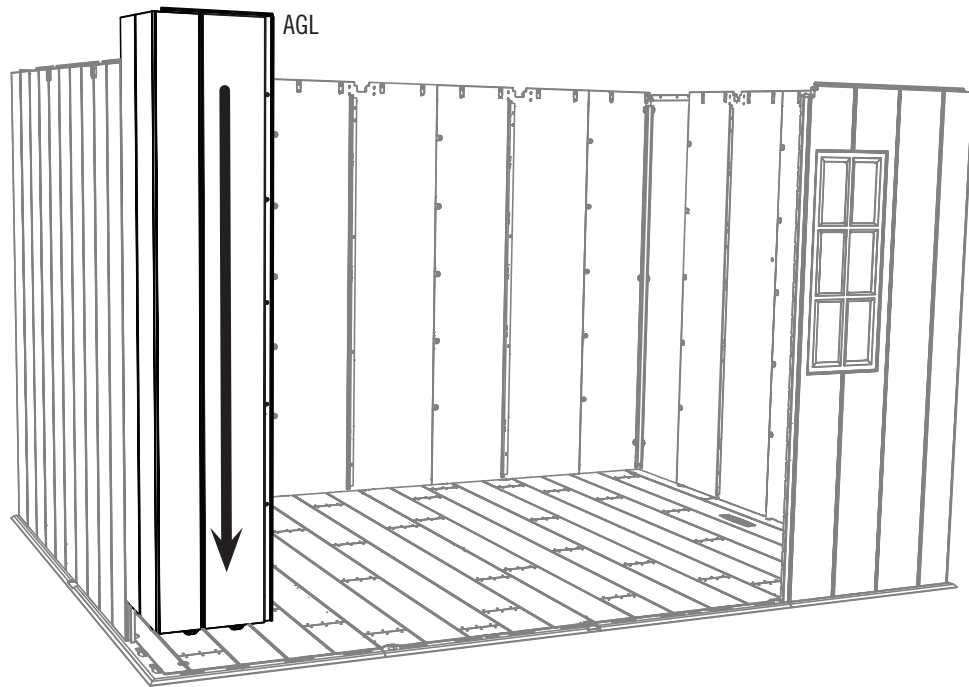

### 7.17



- Insert tabs at the bottom of the **Left Window Wall Panel (BDH)** into the third and fourth slots from the front, right corner of the Floor. Slide the Panel to the left. Secure the two Panels using five (5) **Screws (ADZ)**.
- Insérer les languettes au bord inférieur du **panneau mural gauche pour la fenêtre (BDH)** dans les troisième et quatrième rainures du coin droit du plancher. Faire glisser le panneau à gauche. Fixer bien les deux panneaux à l'aide de cinq (5) **vis (ADZ)**.
- Insertar las lengüetas al borde inferior del **panel mural izquierdo para la ventana (BDH)** en las tercera y quarta ranuras de la esquina derecha del piso. Deslizar el panel a la izquierda. Fijar los dos paneles usando cinco (5) **tornillos (ADZ)**.

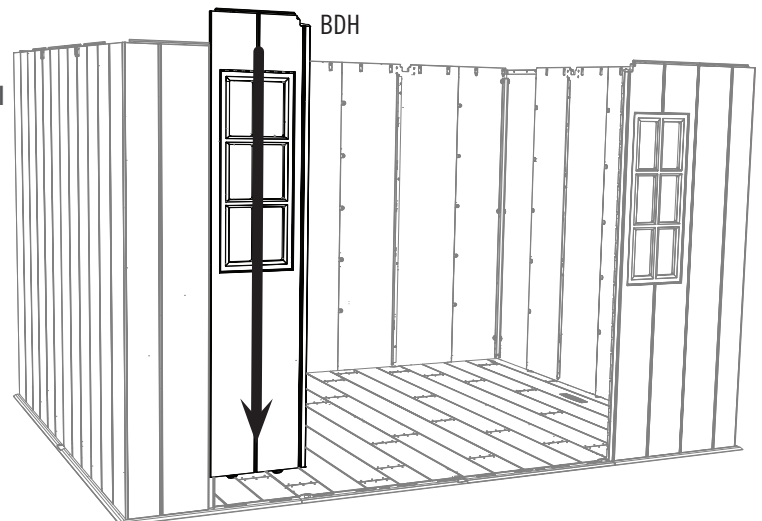

# 8

## SHELVING INSTALLATION / INSTALLATION DU RAYONNAGE / INSTALACIÓN DE LA ESTANTERÍA



### HARDWARE REQUIRED / QUINCAILLERIE REQUISE / HERRAJE REQUERIDO

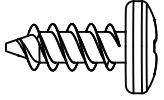

ADZ (x28)



AIY (x4)



### PARTS REQUIRED / PIÈCES REQUISES / PIEZAS REQUERIDAS

*Plastic Parts / Pièces en plastique / Piezas de plástico*



AFV (x2)



### TOOLS REQUIRED (NOT INCLUDED) / OUTILS REQUIS (NON INCLUS) / INSTRUMENTAL REQUERIDO (NO INCLUIDO)



## ► SECTION 8 (CONTINUED) / SECTION 8 (SUITE) / SECCIÓN 8 (CONTINUACIÓN)

TOOLS AND HARDWARE REQUIRED / OUTILS ET QUINCAILLERIE REQUIS / INSTRUMENTAL Y HERRAJE REQUERIDOS



AIY (x2)

### 8.1

- Insert the **Shelf Brackets (AIY)** into the slots in the Wall Support Channels. **The Brackets must be at the same height.**
- Insérer les **équerres (AIY)** dans les fentes dans les canaux de support muraux. **Les équerres doivent être de la même hauteur.**
- Insertar las **escuadras (AIY)** dentro de las ranuras en los canales de soporte murales. **Las escuadras deben estar a la misma altura.**

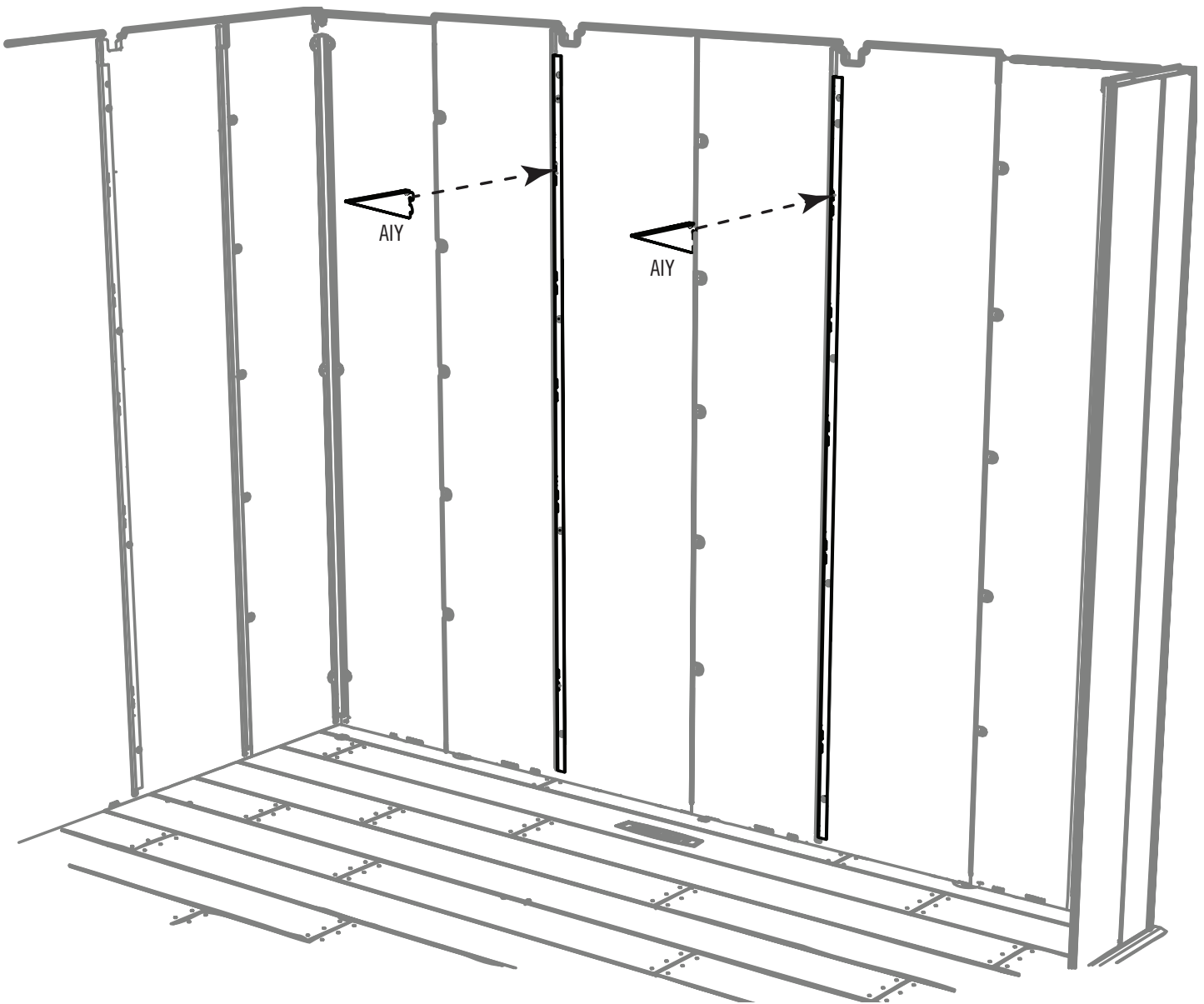



## ► SECTION 8 (CONTINUED) / SECTION 8 (SUITE) / SECCIÓN 8 (CONTINUACIÓN)

TOOLS AND HARDWARE REQUIRED / OUTILS ET QUINCAILLERIE REQUIS / INSTRUMENTAL Y HERRAJE REQUERIDOS

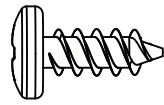

ADZ (x12)



AIY (x2)

### 8.2

- Fold the flaps on the ends of the **Shelf (AFV)** up, and set the Shelf onto the Brackets. **The notches along the long edge should be against the rear wall.**
- Plier les volets sur les extrémités de l'**étagère (AFV)** vers le haut, et placer la tablette sur les supports. **Les fentes le long de l'extrémité longue devraient être contre le mur arrière.**
- Doblar las aletas del **estante (AFV)** hacia arriba, y colocar el estante en las escuadras. **Las muescas a lo largo del borde largo debe quedarse contra el muro trasero.**

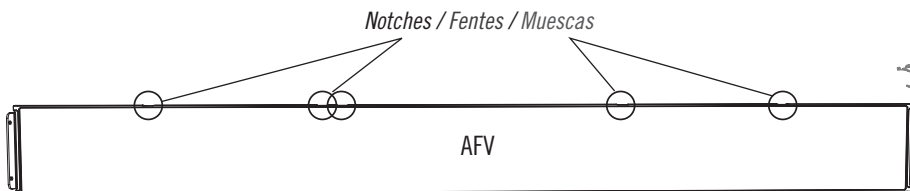
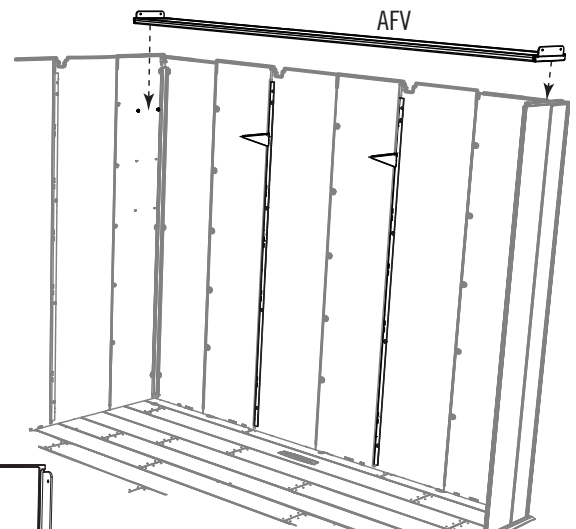

### 8.3

- Attach the **Shelf (AFV)** to the Corner Wall Panels and Shelf Brackets using six (6) **Screws (ADZ)**. **Repeat this section for the other side of the shed.**
- Attacher l'**étagère (AFV)** vers les panneaux muraux de coin et canaux de support muraux en utilisant six (6) **vis (ADZ)**. **Répéter cette section pour l'autre côté de l'abri.**
- Sujetar el **estante (AFV)** a los paneles murales de esquina y las escuadras usando seis (6) **tornillos (ADZ)**. **Repetir esta sección para el otro lado de la caseta.**

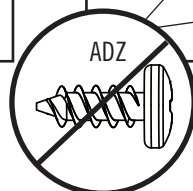
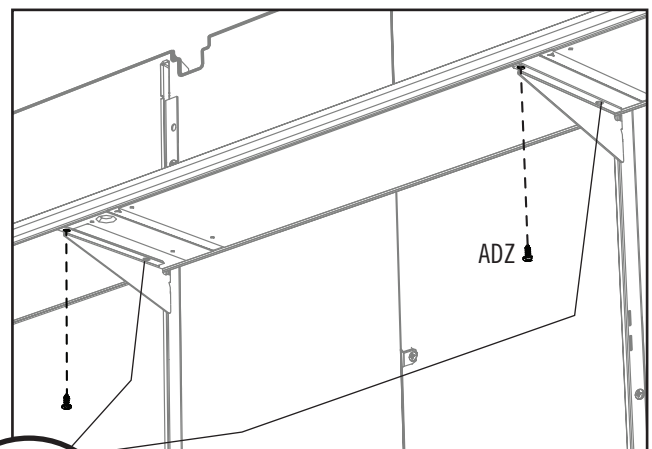
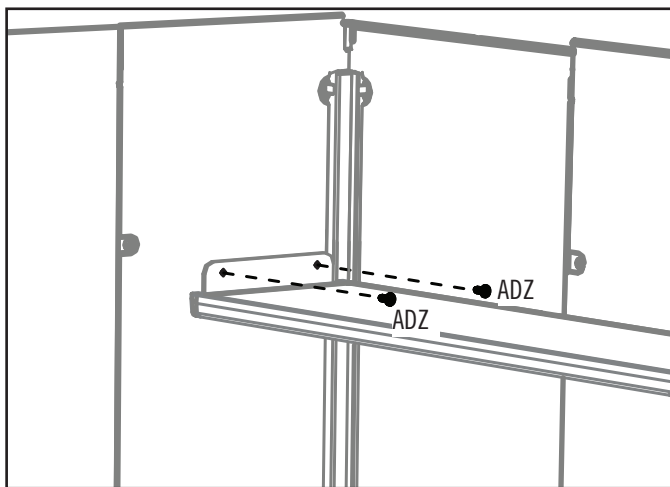

⚠  
↓ ≈23 kg (50 lb)

# 9

## ROOF ASSEMBLY / ASSEMBLAGE DU TOIT / ENSAMBLE DEL TEJADO



### HARDWARE REQUIRED / QUINCAILLERIE REQUISE / HERRAJE REQUERIDO

Hardware Bag / Sac quincaillerie / Bolsa de herraje

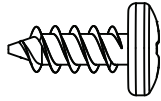

ADZ (x160)

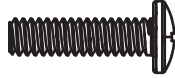

DTV (x2)



AHP (x2)

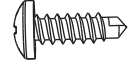

BHJ (x2)

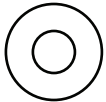

AEE (x2)



CXK (x2)

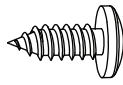

ADX (x26)

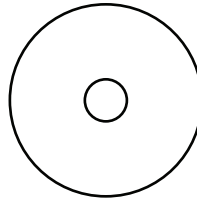

AED (x24)

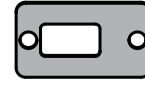

AHL (x1)

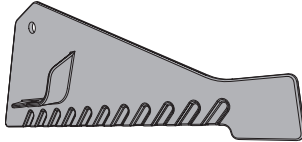

ECR (x1)

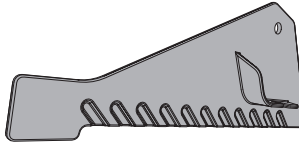

ECS (x1)



ADK (x2)



BZA (x2)

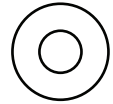

AEE (x4)



### PARTS REQUIRED / PIÈCES REQUISES / PIEZAS REQUERIDAS

Metal Parts / Pièces en métal / Piezas de metal



AFL (x6)

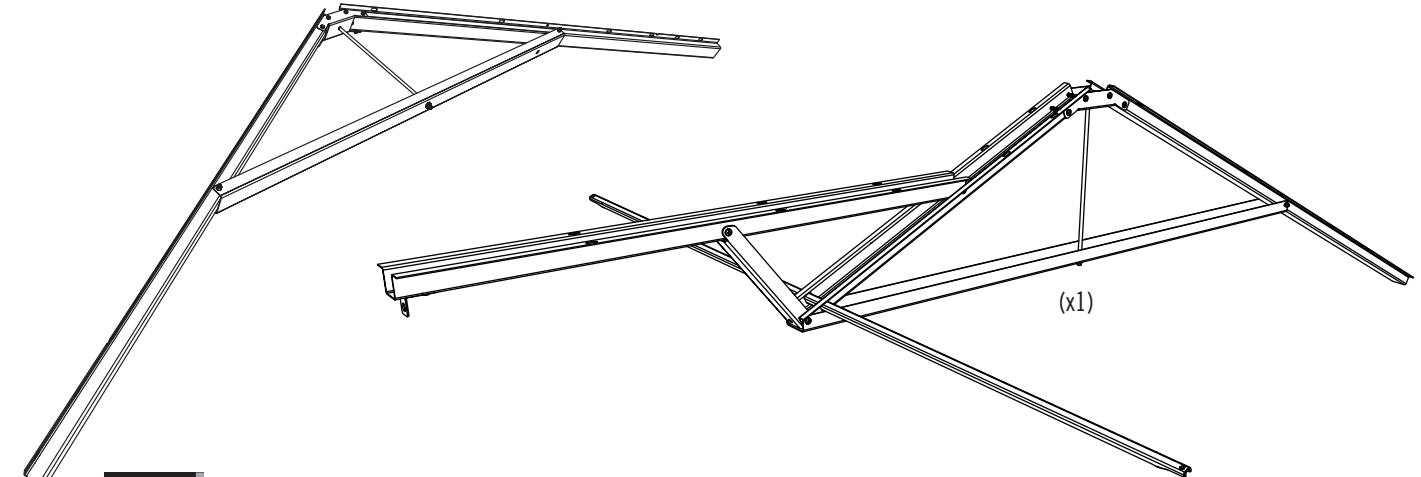

(x2)



*Note: This notched end goes towards the front of the shed.  
Remarque : Cette extrémité encochée va vers la partie avant de l'abri.  
Nota: Este extremo muescado va hacia la parte delantera de la caseta.*



PARTS REQUIRED / PIÈCES REQUISES / PIEZAS REQUERIDAS

Plastic Parts / Pièces en plastique / Piezas de plástico

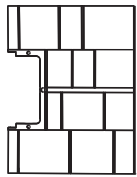

AFW (116) (x1)

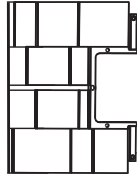

AGG (115) (x1)

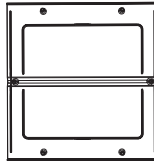

AHC (x4)

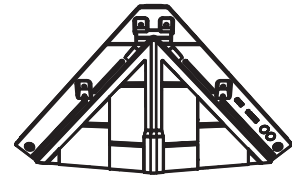

DRB (x1)

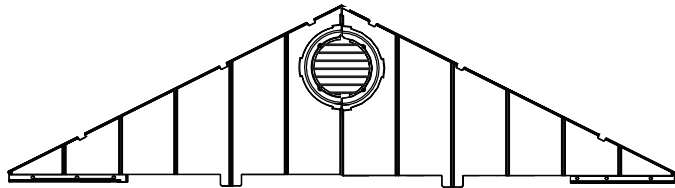

(x2)

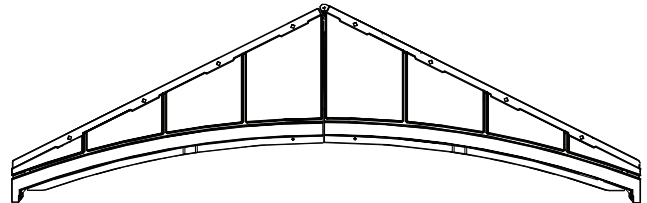

(x1)

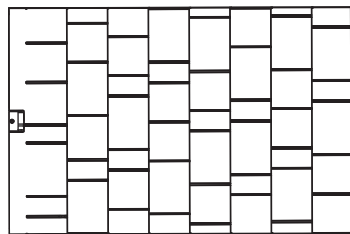

AGQ (x6)

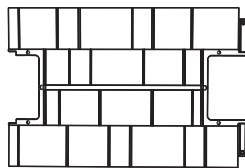

AFY (117) (x3)

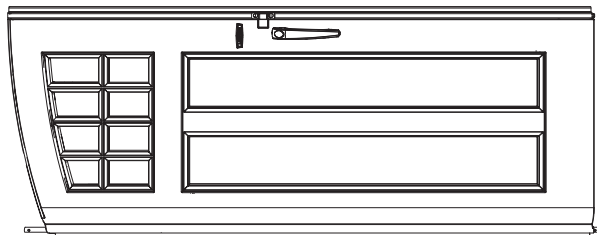

(x1)

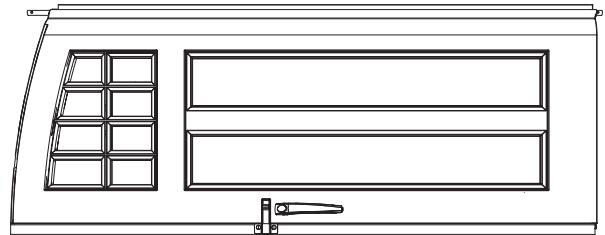

(x1)

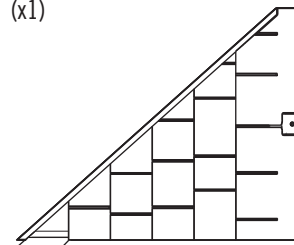

BDR (x1)

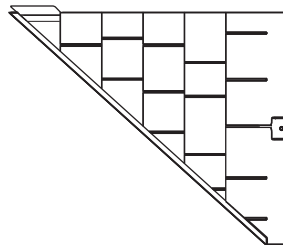

BDS (x1)

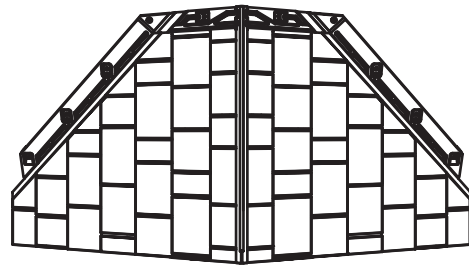

DRA (x1)



TOOLS REQUIRED / OUTILS REQUIS / INSTRUMENTAL REQUERIDO



3/8 in/po (10 mm)

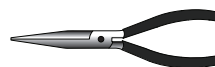

## ► SECTION 9 (CONTINUED) / SECTION 9 (SUITE) / SECCIÓN 9 (CONTINUACIÓN)

TOOLS AND HARDWARE REQUIRED / OUTILS ET QUINCAILLERIE REQUIS / INSTRUMENTAL Y HERRAJE REQUERIDOS

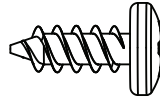

ADZ (x14)

### 9.1



- Set a Side Gable down onto the right side of the shed.
- Mettre un pignon latéral sur le côté droit de l'abri.
- Meter una fachada lateral en el lado derecho de la caseta.

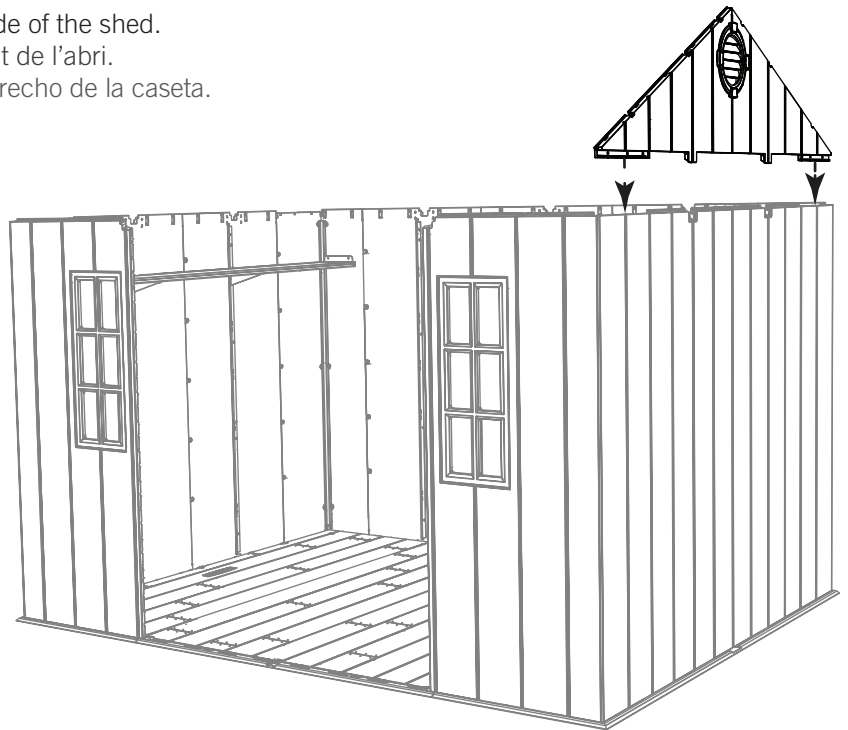

### 9.2

- Secure a Side Gable to the Shed using fourteen (14) **Screws (ADZ)**.
- Fixer un pignon latéral à l'abri à l'aide de quatorze (14) **vis (ADZ)**.
- Fijar una fachada lateral a la caseta usando catorce (14) **tornillos (ADZ)**.

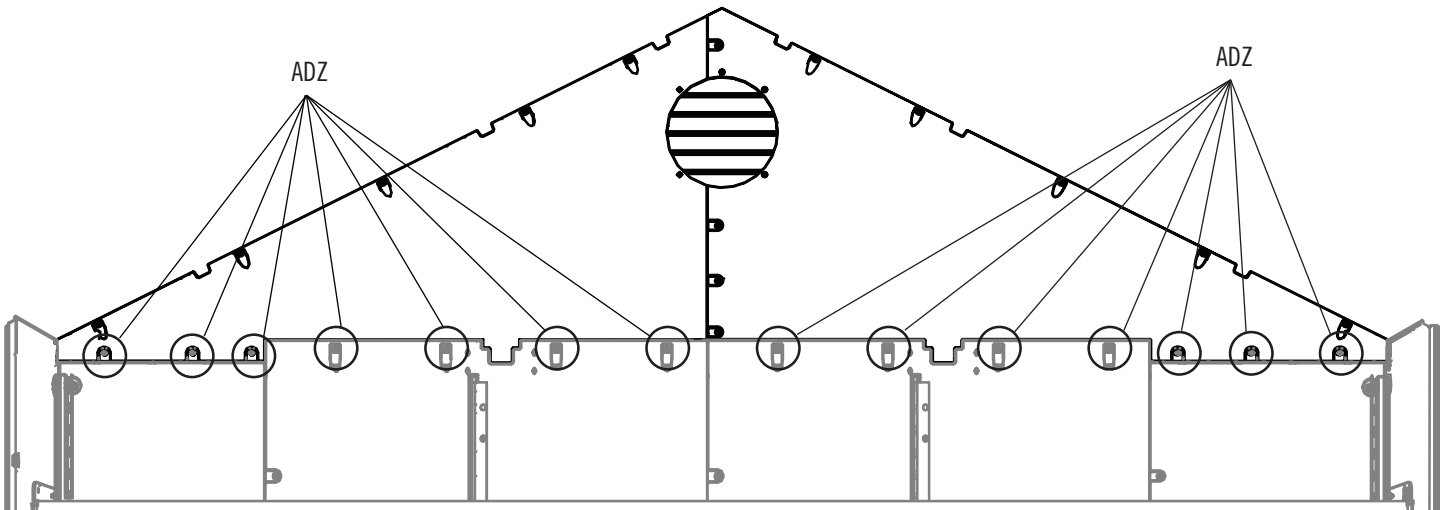

## ► SECTION 9 (CONTINUED) / SECTION 9 (SUITE) / SECCIÓN 9 (CONTINUACIÓN)

TOOLS AND HARDWARE REQUIRED / OUTILS ET QUINCAILLERIE REQUIS / INSTRUMENTAL Y HERRAJE REQUERIDOS



### 9.3

- Place a Side Truss into the notches on the rear Wall Panel and Right Front Window Wall Panel. While another adult holds this in place, continue to the next step.
- Mettre une ferme latérale dans les encoches sur le panneau mural arrière et le panneau mural avant droit pour la fenêtre. Pendant qu'un autre adulte soutient la ferme en place, continuer à la prochaine étape.
- Meter una cercha lateral en las muescas en el panel mural trasero y el panel mural delantero derecho para la ventana. Mientras que otro adulto mantenga la cercha en su lugar, seguir al próximo paso.

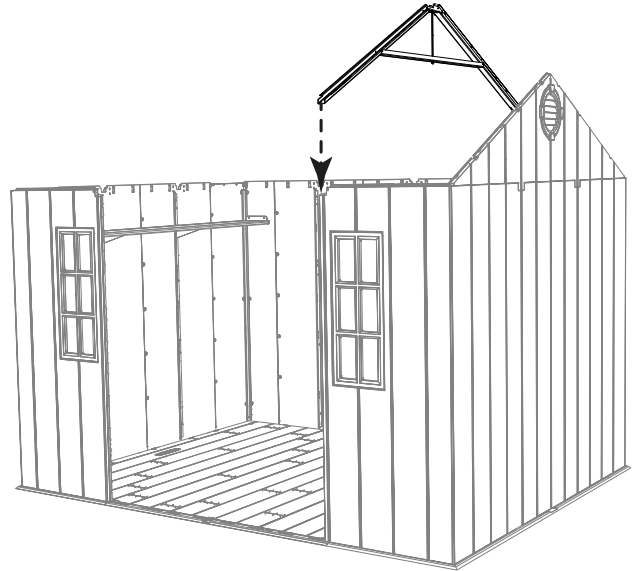

### 9.4

- Set the **Roof Panel (AGQ)** down onto the Wall Panel, Gable, and Truss. The groove at the bottom of the Roof Panel sets over the top of the Wall Panel. Ensure the alignment nub fits into the notch in the Truss.
- Mettre le **panneau de toit (AGQ)** dans le panneau mural, le pignon, et la ferme. Mettre la rainure au bord inférieur du panneau de toit sur la partie supérieure du panneau mural. Mettre la petite bosse d'alignement dans l'encoche de la ferme.
- Meter el **panel de tejado (AGQ)** en el panel de pared, la fachada, y la cercha. Colocar la ranura a lo largo del borde inferior del panel de tejado sobre la parte superior del panel de pared. Encajar el bulto de alineamiento en la muesca en la cercha.

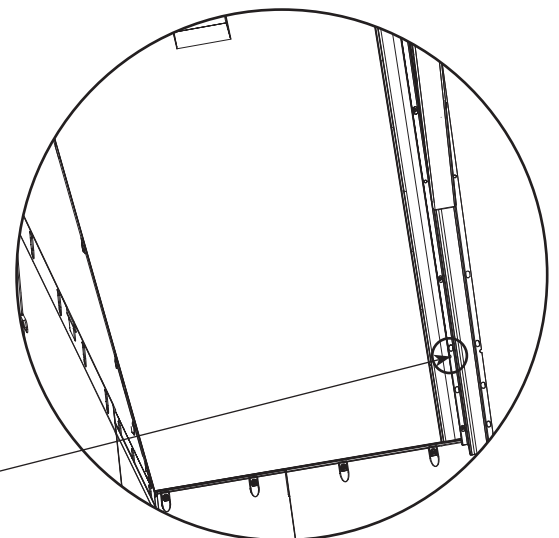
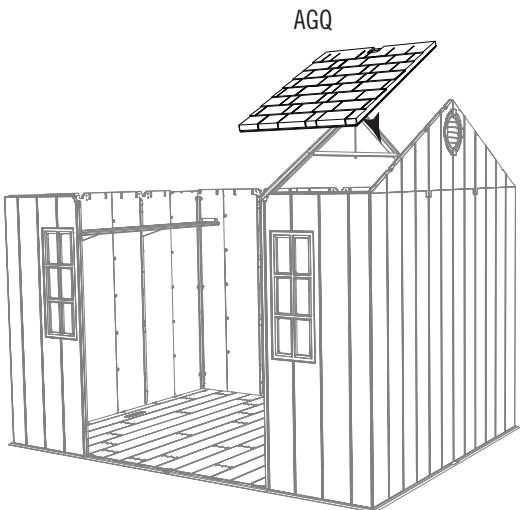

Alignment nub  
Petite bosse d'alignement  
Bulto de alineamiento

## ► SECTION 9 (CONTINUED) / SECTION 9 (SUITE) / SECCIÓN 9 (CONTINUACIÓN)

TOOLS AND HARDWARE REQUIRED / OUTILS ET QUINCAILLERIE REQUIS / INSTRUMENTAL Y HERRAJE REQUERIDOS

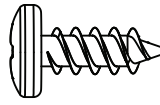

ADZ (x4)

### 9.5

- Align the four holes in the Wall Panel with those at the bottom of the Roof Panel, and insert four (4) **Screws (ADZ)** to secure the Panel in place.
- Aligner les quatre trous dans le panneau mural avec ceux au bord inférieur du panneau de toit, et insérer quatre (4) **vis (ADZ)** pour attacher le panneau en place.
- Alinear los cuatro agujeros en el panel de pared con los al borde inferior del panel de tejado, e insertar cuatro (4) **tornillos (ADZ)** para sujetarlo en su lugar.

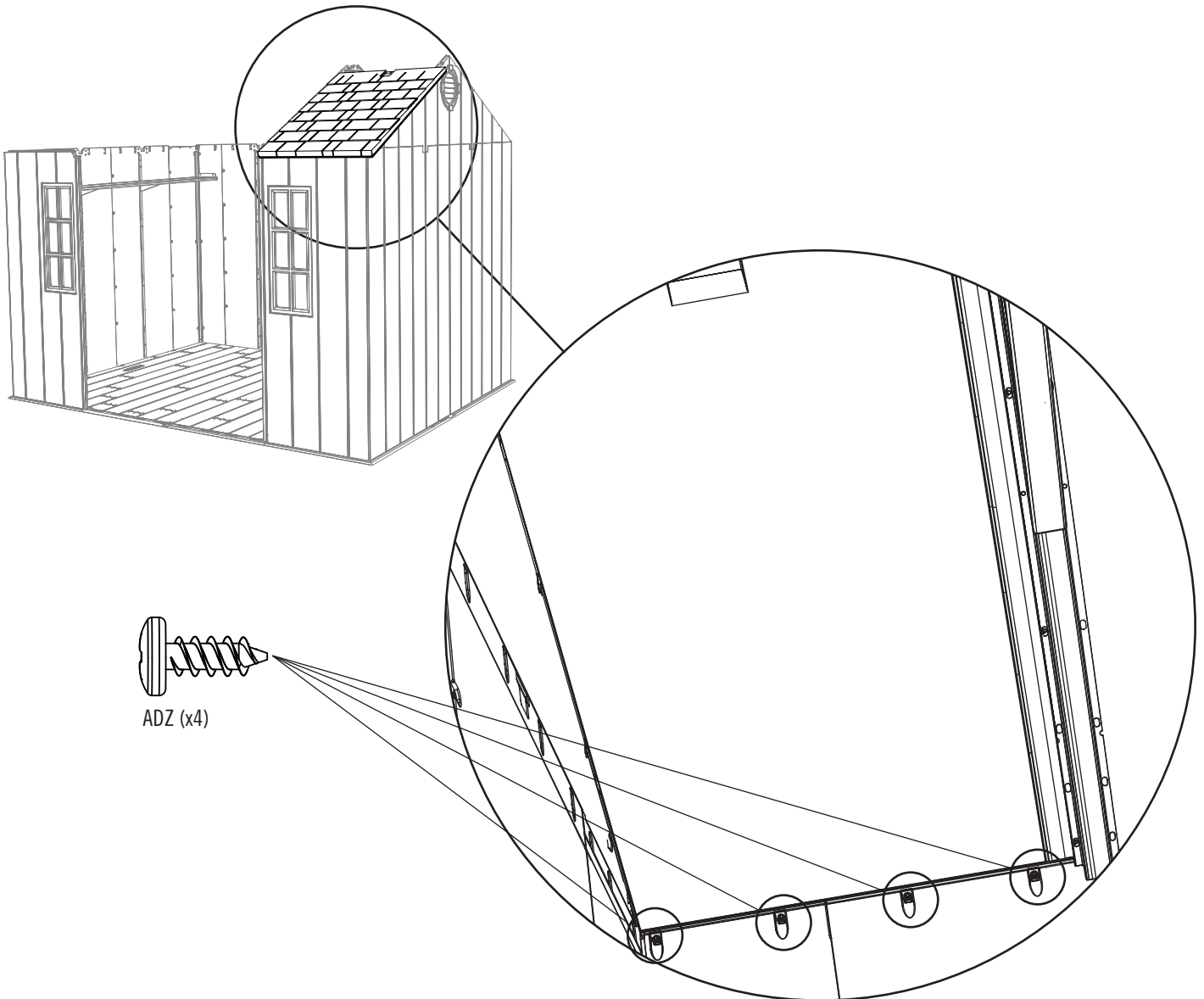

## ► SECTION 9 (CONTINUED) / SECTION 9 (SUITE) / SECCIÓN 9 (CONTINUACIÓN)

TOOLS AND HARDWARE REQUIRED / OUTILS ET QUINCAILLERIE REQUIS / INSTRUMENTAL Y HERRAJE REQUERIDOS

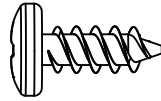

ADZ (x5)

### 9.6

- Insert the first three **Screws (ADZ)** through the Gable and into the Roof Panel and the first two **Screws (ADZ)** through the Truss and into the Roof Panel at the locations shown. Then, insert the **Roof Support (AFL)** into the notches in the Gable and between the Truss and the Roof Panel.
- Insérer les premières trois **vis (ADZ)** à travers le pignon et dans le panneau de toit avec lucarne et les premières deux **vis (ADZ)** à travers la ferme et dans le panneau de toit aux emplacements indiqués. Ensuite, mettre le **support de toit (AFL)** dans les encoches dans le pignon et entre le panneau de toit et la ferme.
- Insertar los primeros tres **tornillos (ADZ)** por la fachada y dentro del panel de tejado con tragaluz y los primeros dos **tornillos (ADZ)** por la cercha y dentro del panel de tejado a las ubicaciones indicadas. Entonces, insertar el **soporte de tejado (AFL)** en las muescas en la fachada y entre la cercha y el panel de tejado.

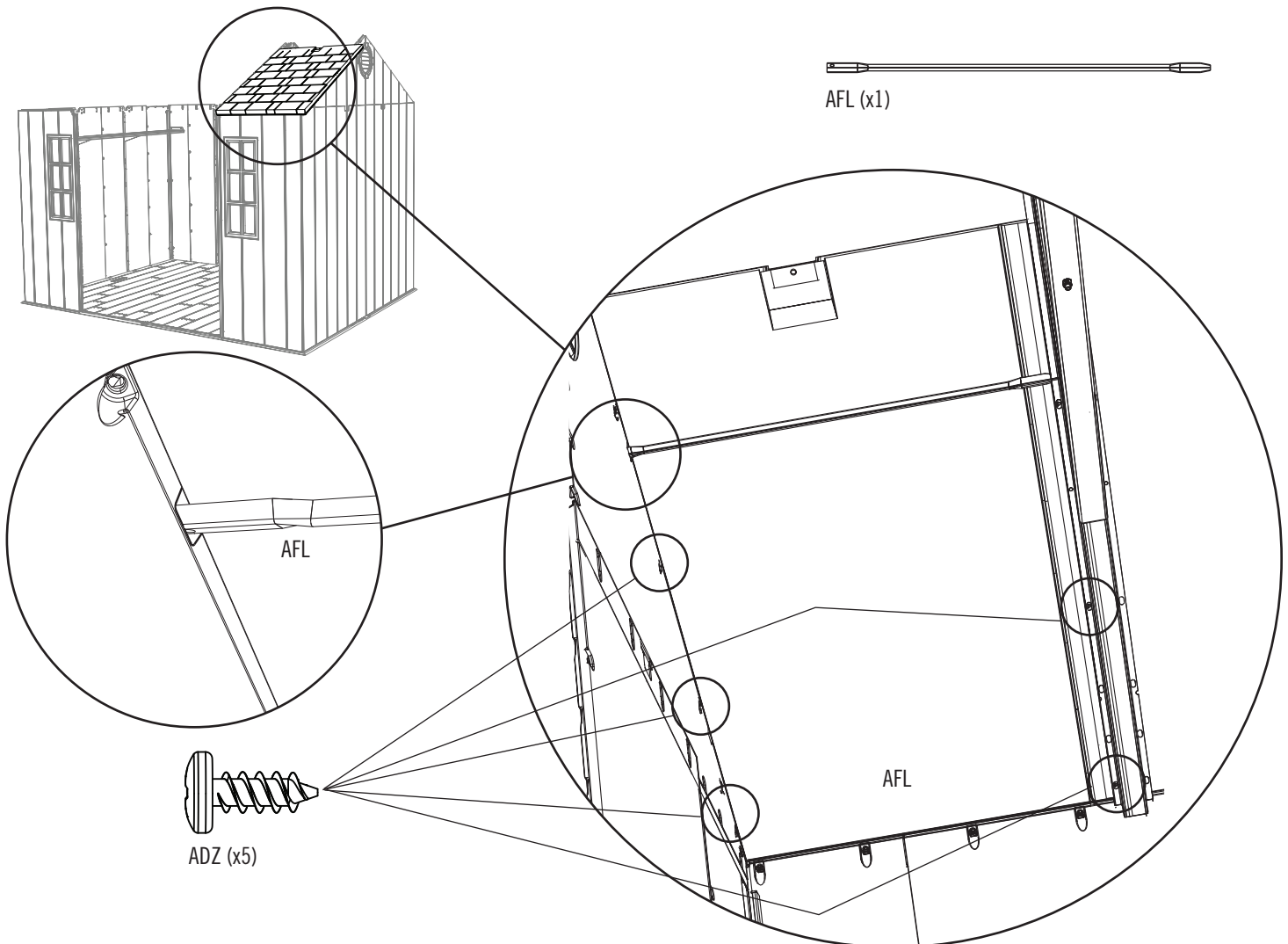



## ► SECTION 9 (CONTINUED) / SECTION 9 (SUITE) / SECCIÓN 9 (CONTINUACIÓN)

TOOLS AND HARDWARE REQUIRED / OUTILS ET QUINCAILLERIE REQUIS / INSTRUMENTAL Y HERRAJE REQUERIDOS

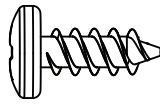

ADZ (x13)

### 9.7

- Insert one **Screw (ADZ)** through the Gable and into the Roof Panel and one **Screw (ADZ)** through the Truss and into the Roof Panel at the locations shown.
- Insérer une **vis (ADZ)** à travers le pignon et dans le panneau de toit et une **vis (ADZ)** à travers la ferme et dans le panneau de toit aux emplacements illustrés.
- Insertar un **tornillo (ADZ)** por la fachada y dentro del panel de tejado y un **tornillo (ADZ)** por la cercha y dentro del panel de tejado a las ubicaciones indicadas.



*Note: Repeat the previous steps for the rear Roof Panel (AGQ).*

*Remarque : Répéter les étapes précédentes pour le panneau de toit (AGQ) arrière.*

*Nota : Repetir los pasos anteriores para el panel de tejado (AGQ) trasero.*

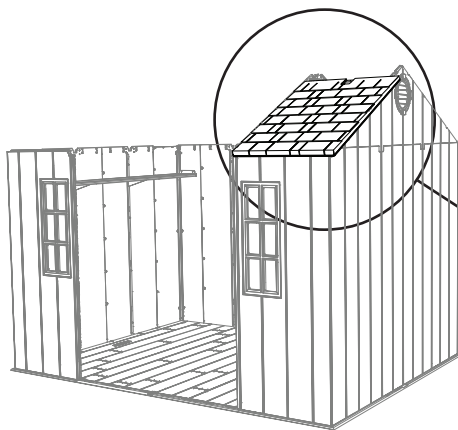

AFL (x1)

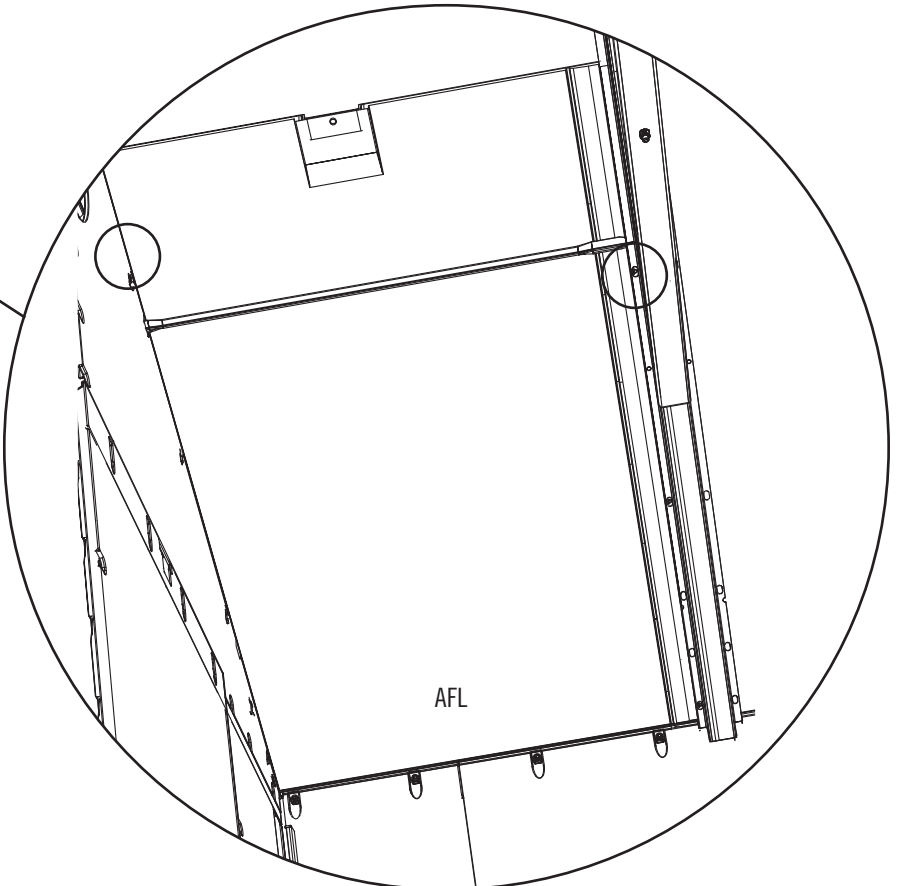
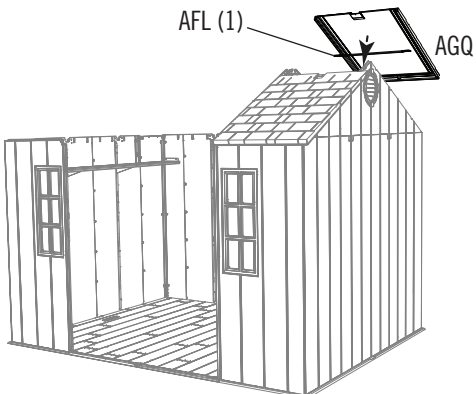

## ► SECTION 9 (CONTINUED) / SECTION 9 (SUITE) / SECCIÓN 9 (CONTINUACIÓN)

TOOLS AND HARDWARE REQUIRED / OUTILS ET QUINCAILLERIE REQUIS / INSTRUMENTAL Y HERRAJE REQUERIDOS

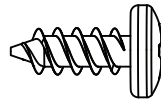

ADZ (x36)

### 9.8

- Repeat steps 9.1–9.7 for the left side of the shed.
- Répéter les étapes 9.1 – 9.7 pour le côté droit de l'abri.
- Repetir los pasos 9.1–9.7 para el lado izquierdo de la caseta.



AFL (x2)

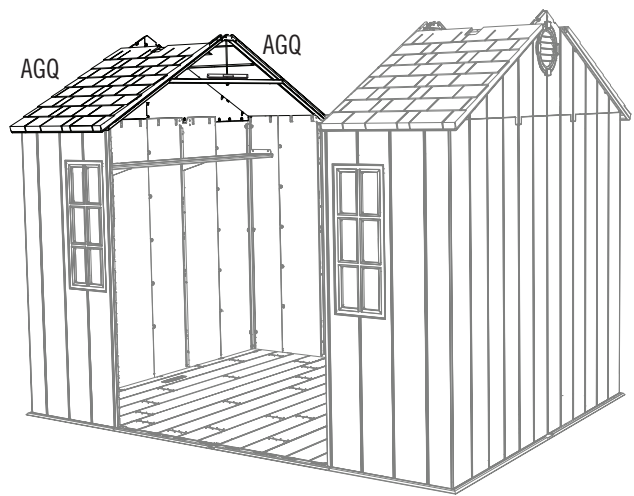
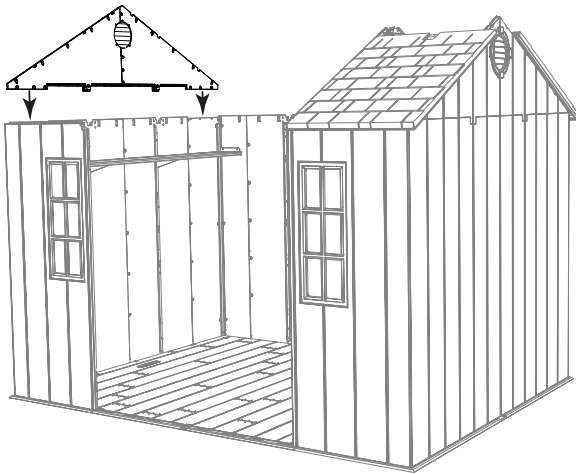

### 9.9

- Place the back of the Center Truss into the notch on the center rear Wall Panel. Then, lift the front of the Truss up so the ends of the Roof Support Tube touch the Side Trusses.
- Mettre l'extrémité arrière de la ferme centrale dans l'encoche sur le panneau mural arrière central. Ensuite, soulever l'extrémité avant de la ferme pour que les extrémités du tube de support touchent les fermes latérales.
- Meter el extremo trasero de la cercha central en la muesca en el panel de tejado central trasero. Entonces, levantar el extremo delantero de la cercha para arriba para que los extremos del tubo de soporte hagan contacto con las cerchas laterales.

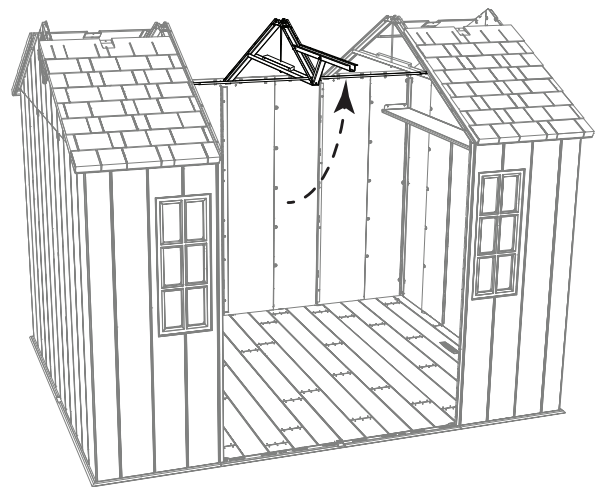
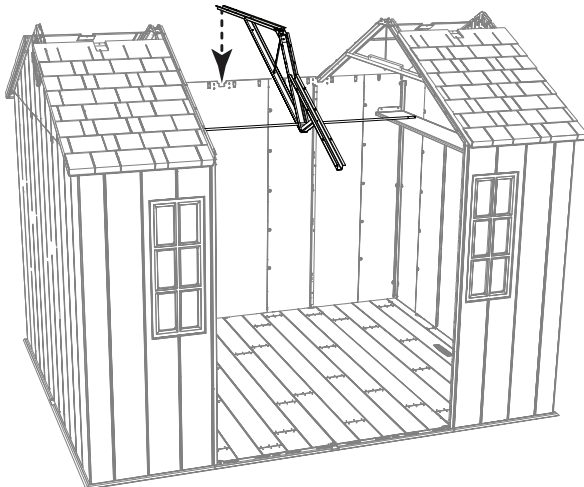

## ► SECTION 9 (CONTINUED) / SECTION 9 (SUITE) / SECCIÓN 9 (CONTINUACIÓN)

TOOLS AND HARDWARE REQUIRED / OUTILS ET QUINCAILLERIE REQUIS / INSTRUMENTAL Y HERRAJE REQUERIDOS



3/8 in/po  
(10 mm)



DTV (x2)

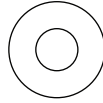

AEE (x2)



CXK (x2)

### 9.10

- Secure the ends of the Support Tube to the Side Truss Channels using the hardware provided.
- Fixer bien les extrémités du tube de support aux fermes latérales à l'aide de la quincaillerie incluse.
- Fijar los extremos del tubo de soporte a las cerchas laterales usando el herraje incluido.

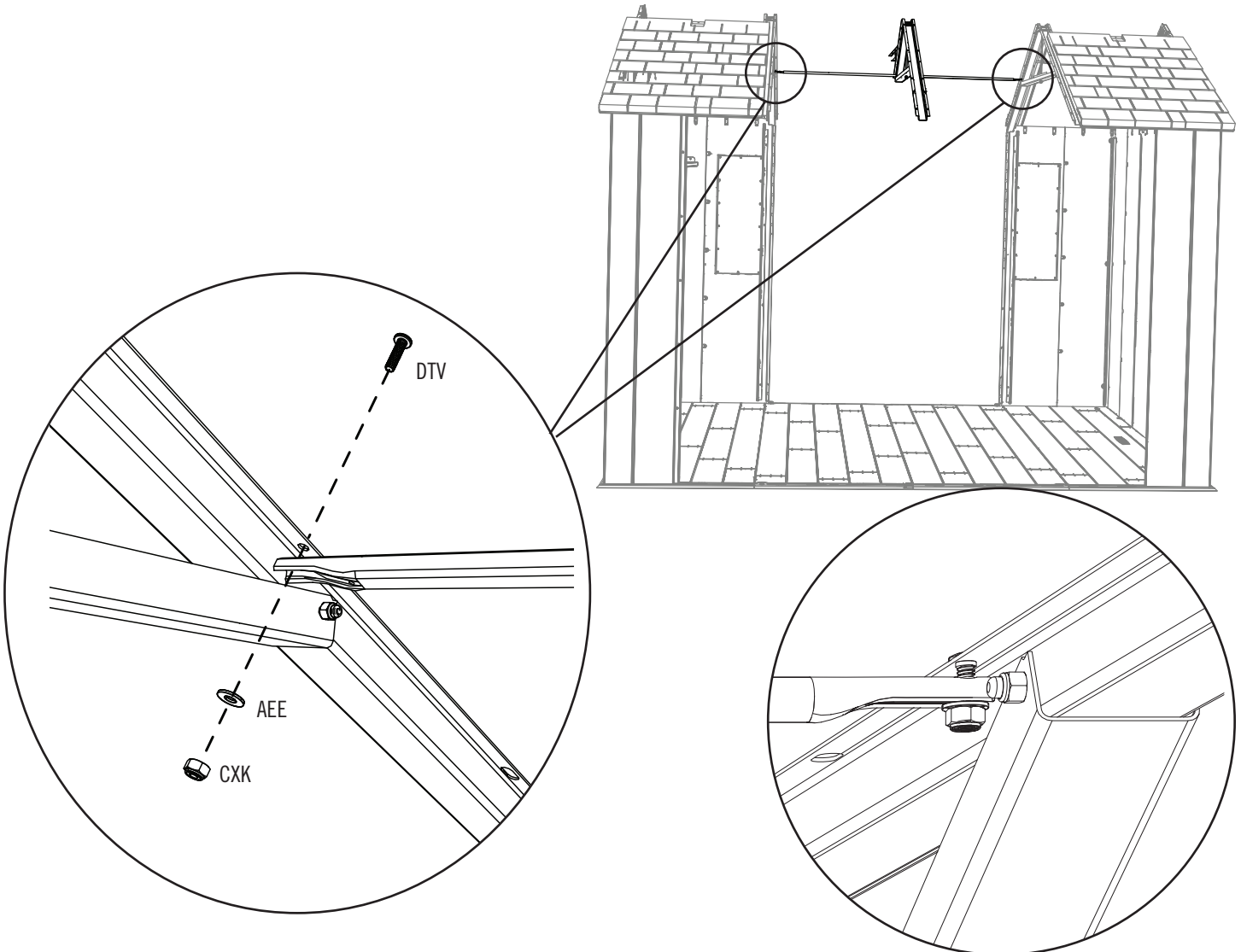

*Note: The Support Tube goes underneath the Lateral Truss.  
Remarque : Attacher bien le tube de support en dessous de la ferme latérale.  
Nota : Se sujete el tubo de soporte debajo la cercha lateral.*

## ► SECTION 9 (CONTINUED) / SECTION 9 (SUITE) / SECCIÓN 9 (CONTINUACIÓN)

TOOLS AND HARDWARE REQUIRED / OUTILS ET QUINCAILLERIE REQUIS / INSTRUMENTAL Y HERRAJE REQUERIDOS



AHP (x2)

### 9.11

- Pull the Hinge Tube down out of the Left Door (the Door without the notched corner) about six inches. Align the hole at the bottom of the Hinge Tube with the slit in the Bushing, and insert the Tube. Insert a **Cotter Pin (AHP)** and bend the ends.
- Étendre le tube d'articulation à peu près quinze centimètres du bord inférieur de la porte (la porte sans encoche). Aligner le trou dans la partie inférieure du tube avec la fente dans la bague, et insérer le tube. Insérer une **clavette (AHP)** et pliez les extrémités.
- Extender el tubo de articulación unos quince centímetros del borde inferior de la puerta (la puerta sin la muesca). Alinear el agujero en la parte inferior del tubo con la rendija en el casquillo, e insertar el tubo. Insertar una **clavija (AHP)** y doble los extremos.

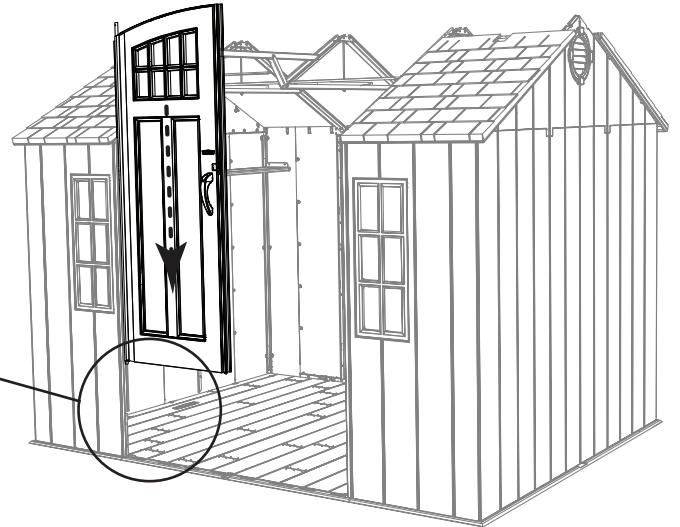
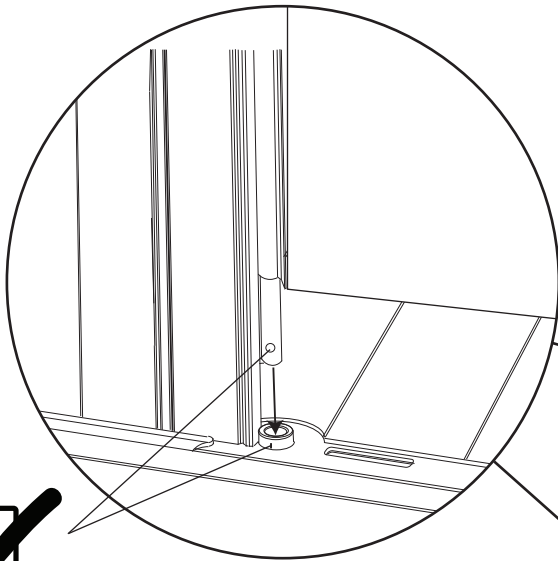

*Note: Repeat this step for the Right Door.  
Remarque : Répéter cette étape pour la porte droite.  
Nota: Repetir este paso para la puerta derecha.*

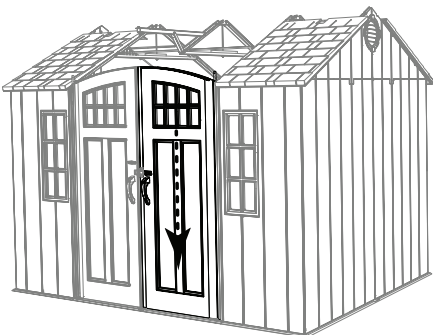
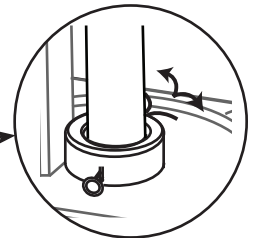
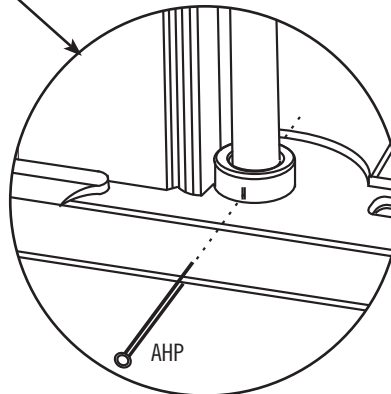

## ► SECTION 9 (CONTINUED) / SECTION 9 (SUITE) / SECCIÓN 9 (CONTINUACIÓN)

TOOLS AND HARDWARE REQUIRED / OUTILS ET QUINCAILLERIE REQUIS / INSTRUMENTAL Y HERRAJE REQUERIDOS

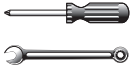

3/8 in/po  
(10 mm)

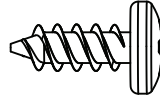

ADZ (x1)

### 9.12

- Slide the holes in the Entry Gable down over the two Hinge Tubes. **The ends of the Gable go in the Trusses.**
- Faire glisser les trous dans le pignon d'entrée sur les deux tubes. **Les extrémités du pignon vont dans les fermes.**
- Deslizar los agujeros en la fachada de entrada sobre los dos tubos. **Los extremos de la fachada van dentro de las cerchas.**

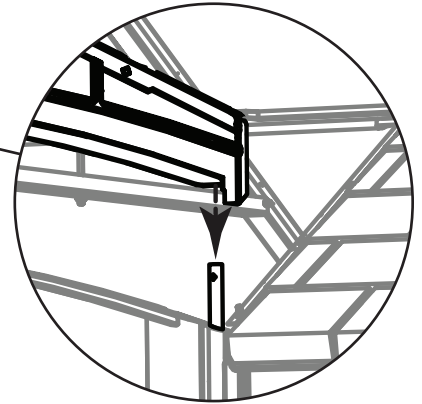
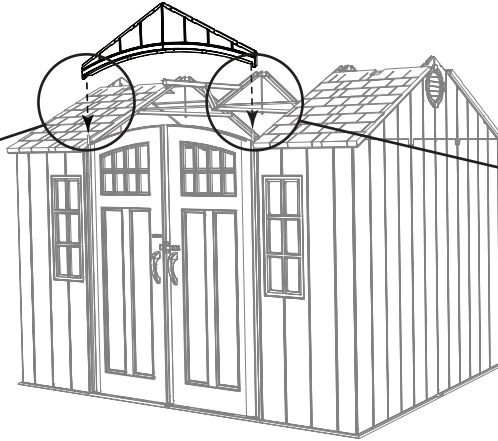

### 9.13

- Set the end of the Center Truss onto the notch in the Front Gable Panel as shown, and secure with one (1) **Screw (ADZ)**.
- Mettre l'extrémité de la ferme centrale dans l'encoche dans la pignon avant comme illustré, et fixer-la à l'aide d'une **vis (ADZ)**.
- Meter el extremo de la cercha central en la muesca en la fachada delantera como se muestra, y fijarla con un **tornillo (ADZ)**.

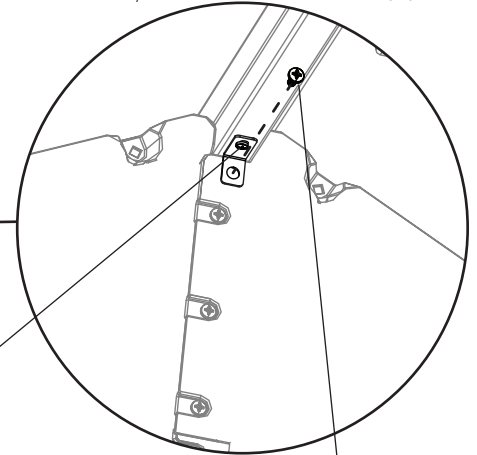
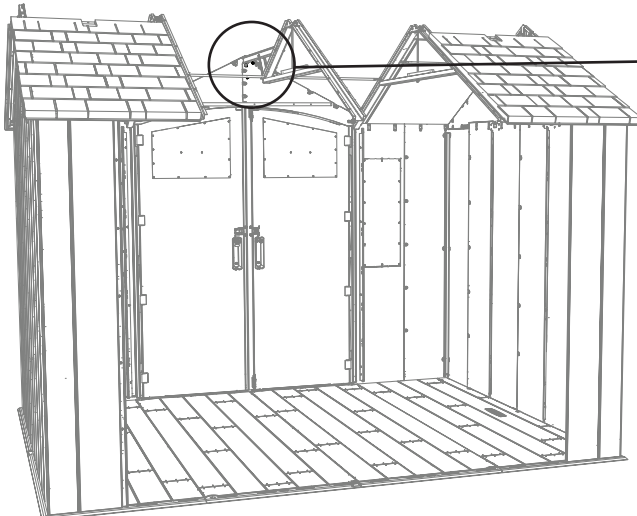

**Note: Tighten this Nut and Bolt now.**  
*Remarque : Serrer ce boulon et l'écrou maintenant.*  
**Nota: Apretar este perno y la tuerca ahora.**

ADZ

## ► SECTION 9 (CONTINUED) / SECTION 9 (SUITE) / SECCIÓN 9 (CONTINUACIÓN)

TOOLS AND HARDWARE REQUIRED / OUTILS ET QUINCAILLERIE REQUIS / INSTRUMENTAL Y HERRAJE REQUERIDOS

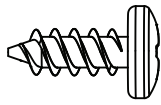

ADZ (x20)

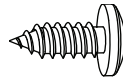

ADX (x2)



AHL (x1)

### 9.14

- Attach the two center, rear Roof Panels using only one Roof Support per Panel.
- Fixer les deux panneaux de toit arrières centraux en utilisant un seul support de toit pour chaque panneau.
- Fijar los dos paneles de tejado traseros centrales usando sólo un Soporte de tejado por panel.



AFL (x2)

AFL

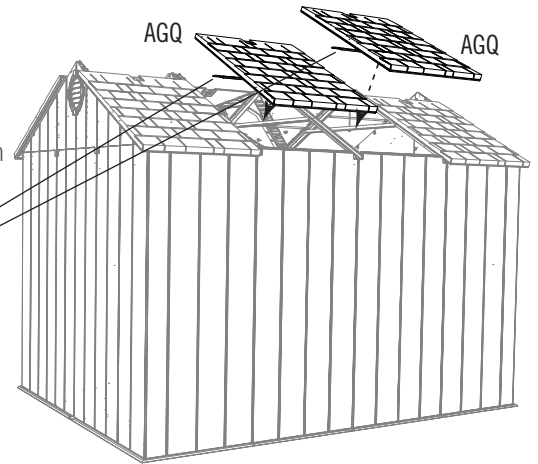

### 9.15

- Attach the **Left Door Strike Plate (AHL)** to the Floor as shown. **Do not overtighten.**
- Fixer la **gâche pour la porte gauche (AHL)** au plancher comme indiqué. **Ne pas trop serrer.**
- Fijar la **placa de impacto para la puerta izquierda (AHL)** al piso como se muestra. **No apretar demasiado.**

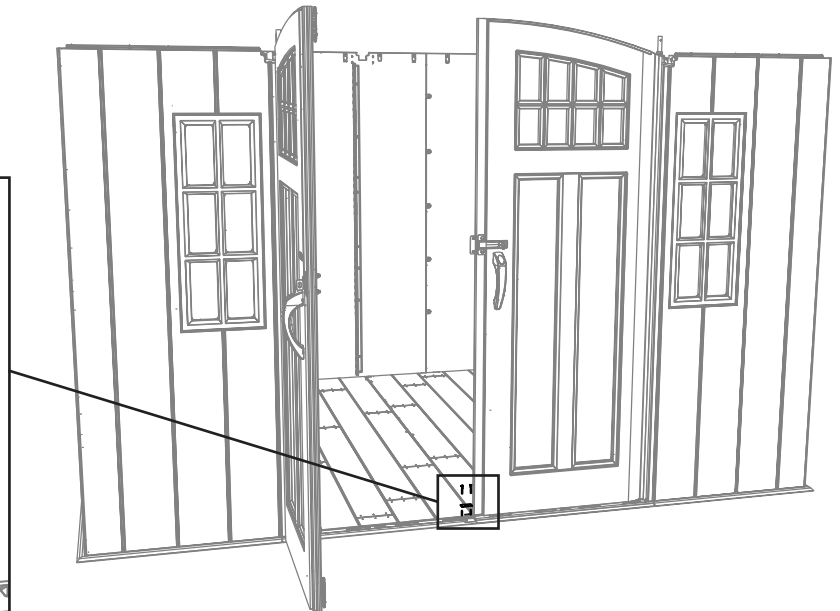
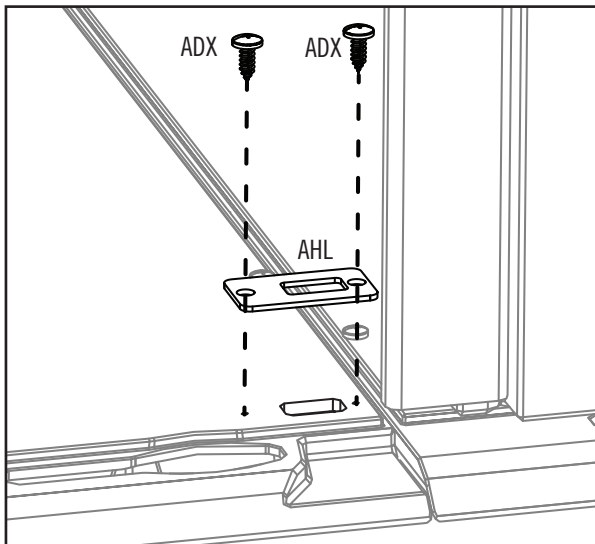



## ► SECTION 9 (CONTINUED) / SECTION 9 (SUITE) / SECCIÓN 9 (CONTINUACIÓN)

TOOLS AND HARDWARE REQUIRED / OUTILS ET QUINCAILLERIE REQUIS / INSTRUMENTAL Y HERRAJE REQUERIDOS

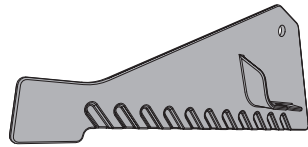

ECS (x1)

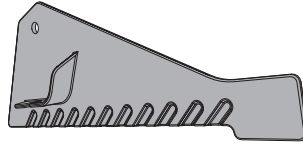

ECR (x1)



ADK (x2)



BZA (x2)

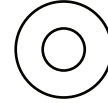

AEE (x4)

### 9.16

- Insert the **Right Drainage Plate (ECS)** into the Right Lateral Truss, and align the notch in the Plate with the first hole in the Truss as shown. Secure with the hardware provided. **Only tighten by hand for now.**
- Insérer la **plaque de drainage droite (ECS)** dans la ferme latérale droite, et aligner l'encoche dans la plaque avec le premier trou dans la ferme comme illustré. Fixer-la bien à la ferme à l'aide de la quincaillerie incluse. **Ne serrer qu'à la main en ce moment.**
- Insertar la **placa derecha para el drenaje (ECS)** dentro de la cercha lateral derecho, y alinear la muesca en la placa con el primer agujero en la cercha. Fijarla a la cercha usando el herraje incluido. **Apretar sólo a mano en este momento.**



*Note: Repeat this step for the Left Drainage Plate (ECR).*

*Remarque : Répétez cette étape pour la plaque de drainage gauche (ECR).*

*Nota: Repetir este paso para la placa izquierda para el drenaje (ECR).*

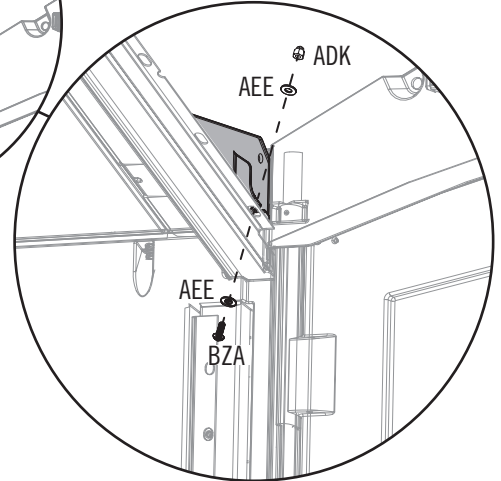
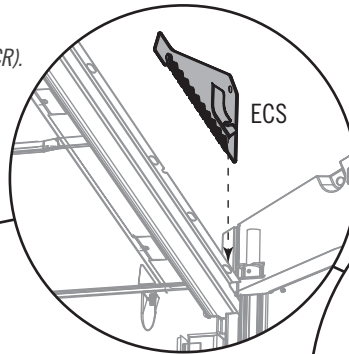
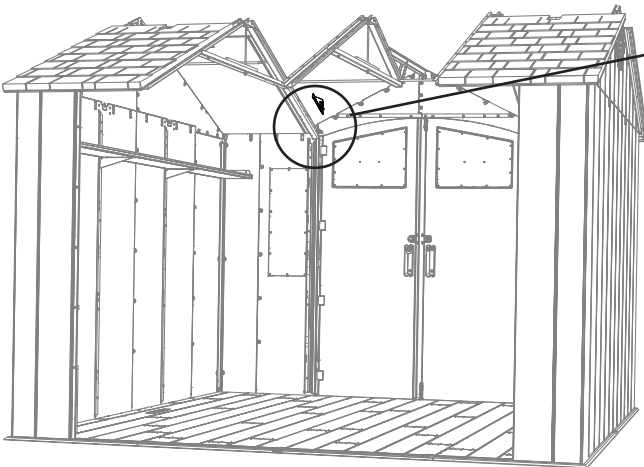



## ► SECTION 9 (CONTINUED) / SECTION 9 (SUITE) / SECCIÓN 9 (CONTINUACIÓN)

TOOLS AND HARDWARE REQUIRED / OUTILS ET QUINCAILLERIE REQUIS / INSTRUMENTAL Y HERRAJE REQUERIDOS

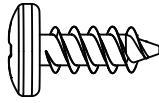

ADZ (x12)

### 9.17

- Fold the ends of the **Large Angled Roof Panel (DRA)**, and set it down onto the shed as shown. Secure the Panel to the Entry Gable and Center Truss with twelve (12) **Screws (ADZ)** at the locations shown.
- Plier les extrémités du **panneau de toit angulaire grand (DRA)**, et mettre-le sur l'abri comme illustré. Fixer-le bien au pignon et à la ferme centrale à l'aide de douze (12) **vis (ADZ)** aux endroits indiqués.
- Doblar los extremos del **panel de tejado angular grande (DRA)**, y colocarlo en la caseta como se muestra. Fijarlo a la fachada y la cercha central usando doce (12) **tornillos (ADZ)** a las ubicaciones indicadas.



*Note: Fold these ends upward before installing.  
Note : Plier ces rabats en haut avant d'installer.  
Nota: Doblar estas solapas hacia arriba antes de instalar.*

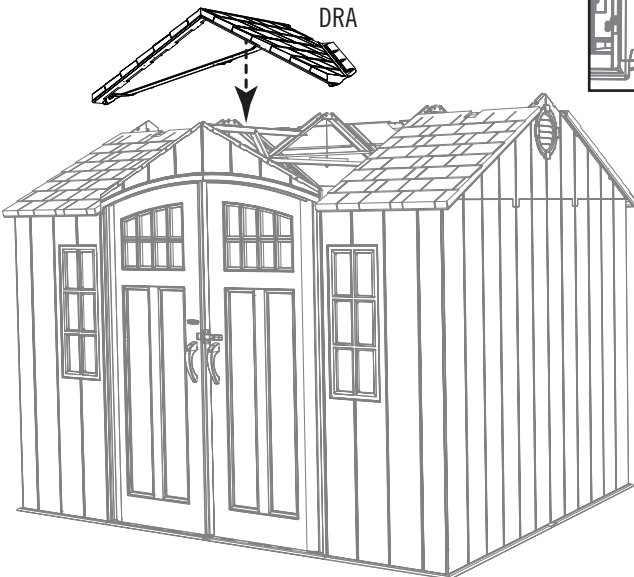
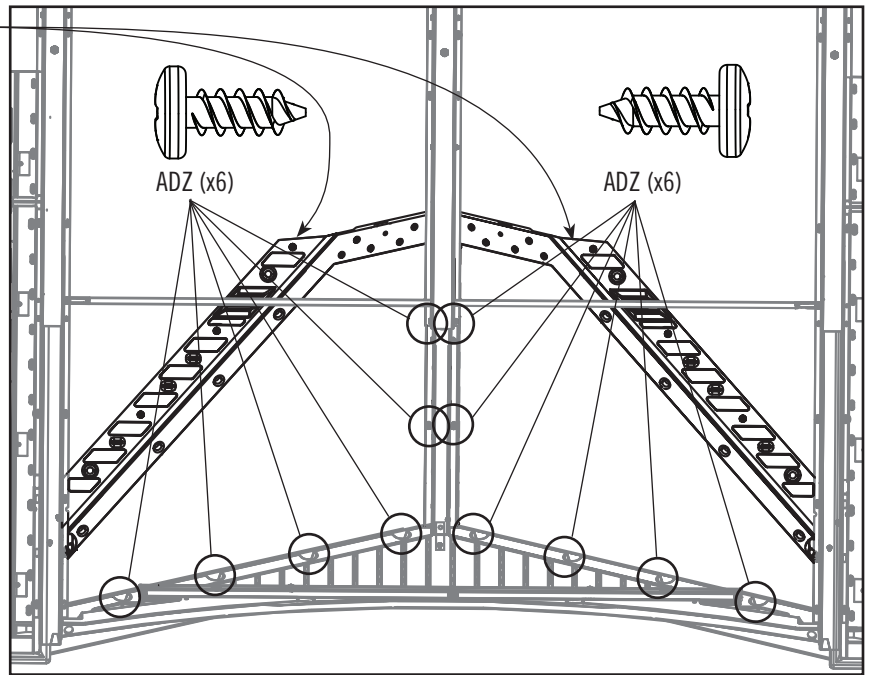

## ► SECTION 9 (CONTINUED) / SECTION 9 (SUITE) / SECCIÓN 9 (CONTINUACIÓN)

TOOLS AND HARDWARE REQUIRED / OUTILS ET QUINCAILLERIE REQUIS / INSTRUMENTAL Y HERRAJE REQUERIDOS

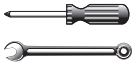

3/8 in/po  
(10 mm)

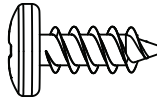

ADZ (x2)

### 9.18

- Secure the Drainage Plates from step 9.16 to the Roof at the location shown. Tighten the Nut on the Drainage Plate now.
- Fixer les plaques de drainage des étapes 9.16 au toit à l'endroit indiqué. Serrer l'écrou dans la plaque de drainage.
- Fijar las placas de drenaje de los pasos 9.16 al tejado a la ubicación indicada. Apretar la tuerca en la placa de drenaje ahora.

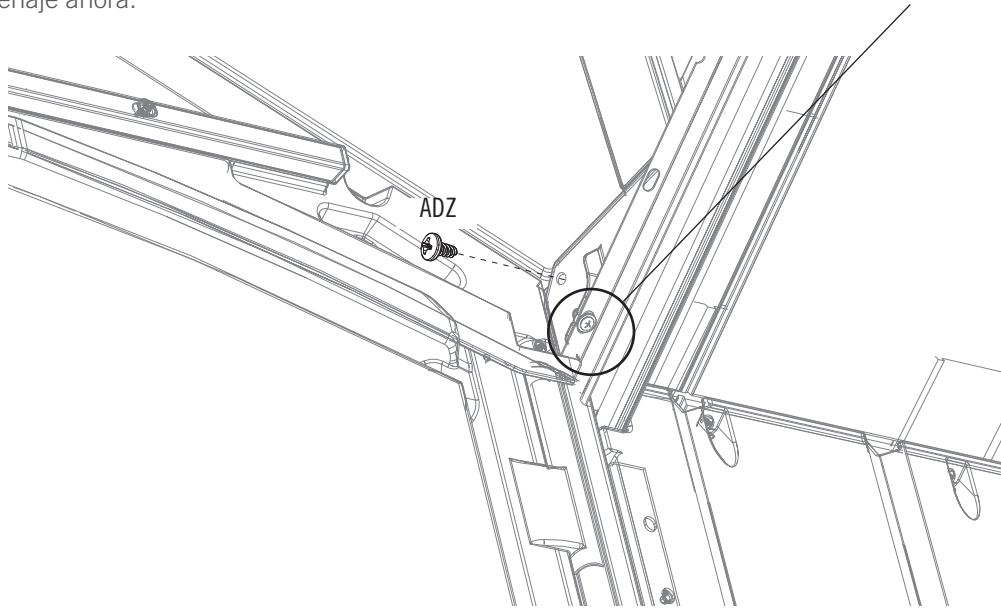

*Note: Repeat this step for the other Drainage Plate.*  
*Remarque : Répéter cette étape pour l'autre plaque de drainage.*  
*Nota: Repetir este paso para la otra placa de drenaje.*

## ► SECTION 9 (CONTINUED) / SECTION 9 (SUITE) / SECCIÓN 9 (CONTINUACIÓN)

TOOLS AND HARDWARE REQUIRED / OUTILS ET QUINCAILLERIE REQUIS / INSTRUMENTAL Y HERRAJE REQUERIDOS

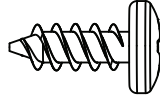

ADZ (x20)

### 9.19

- An adult must apply a downward pressure on **Panel (DRB)** during the insertion of the **Screws (ADZ)**.
- Une adulte doit appliquer pression sur le **panneau (DRB)** pendant l'insertion des **vis (ADZ)**.
- Un adulto debe aplicar una presión de arriba en el **panel (DRB)** durante la inserción de los **tornillos (ADZ)**.

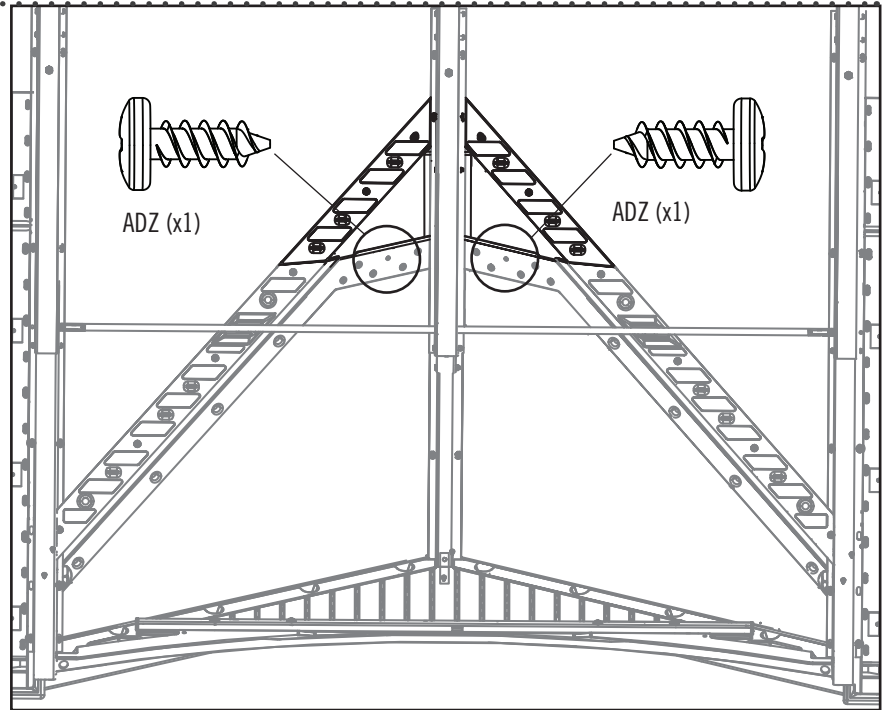
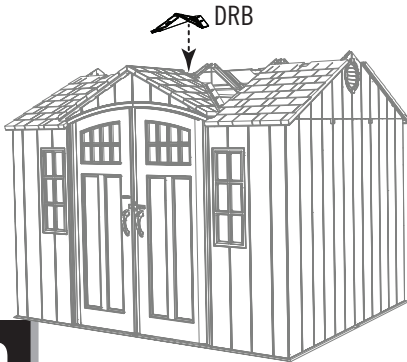

### 9.20

- An adult must apply a downward pressure on **Panels (BDS & BDR)** during the insertion of the **Screws (ADZ)**.
- Une adulte doit appliquer pression sur les **panneaux (BDS et BDR)** pendant l'insertion des **vis (ADZ)**.
- Un adulto debe aplicar una presión de arriba en los **paneles (BDS y BDR)** durante la inserción de los **tornillos (ADZ)**.

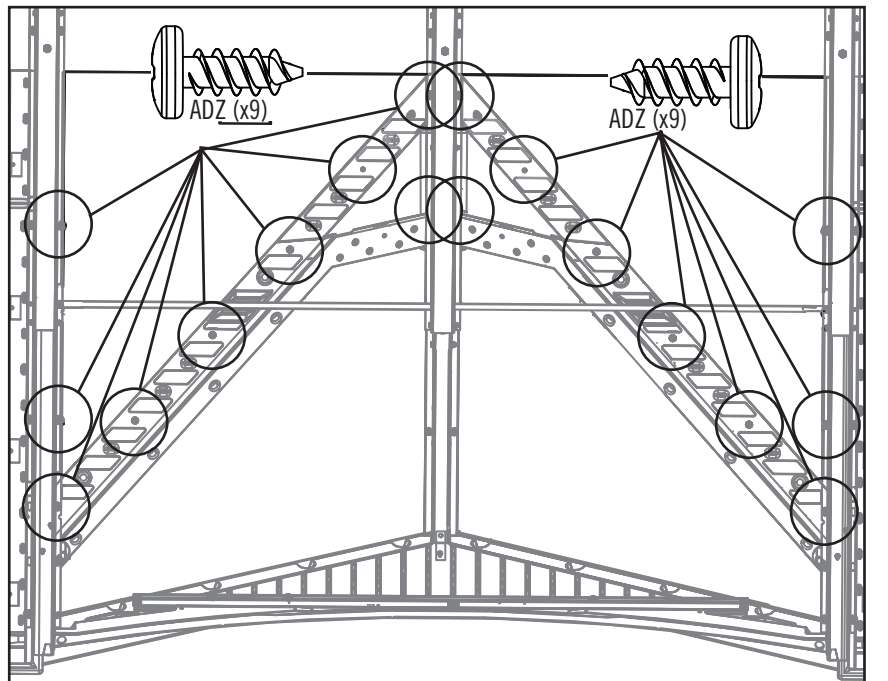
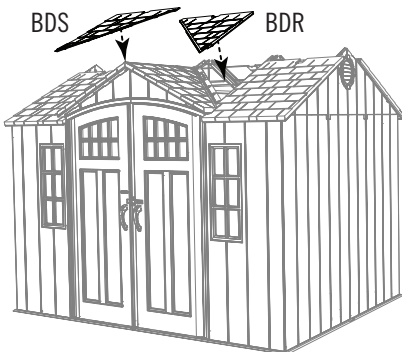

## ► SECTION 9 (CONTINUED) / SECTION 9 (SUITE) / SECCIÓN 9 (CONTINUACIÓN)

TOOLS AND HARDWARE REQUIRED / OUTILS ET QUINCAILLERIE REQUIS / INSTRUMENTAL Y HERRAJE REQUERIDOS

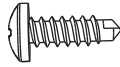

BHJ (x2)

### 9.21

- Use an electric screwdriver to Insert a **Self Tapping Screw (BHJ)** through the plastic of the Gable and into the Door Hinge Tube at the location shown.
- Employer un perceuse électrique pour insérer une **vis autotaraudeuse (BHJ)** à travers le pignon et dans la charnière de la porte à l'endroit indiqué.
- Utilizar un taladro eléctrico para introducir un **tornillo auto-roscante (BHJ)** a través la fachada y dentro de la bisagra a la ubicación indicada.



*Note: Repeat this step for the Right Door.*

*Remarque : Répéter cette étape pour la porte droite.*

*Nota: Repetir este paso para la puerta derecha.*

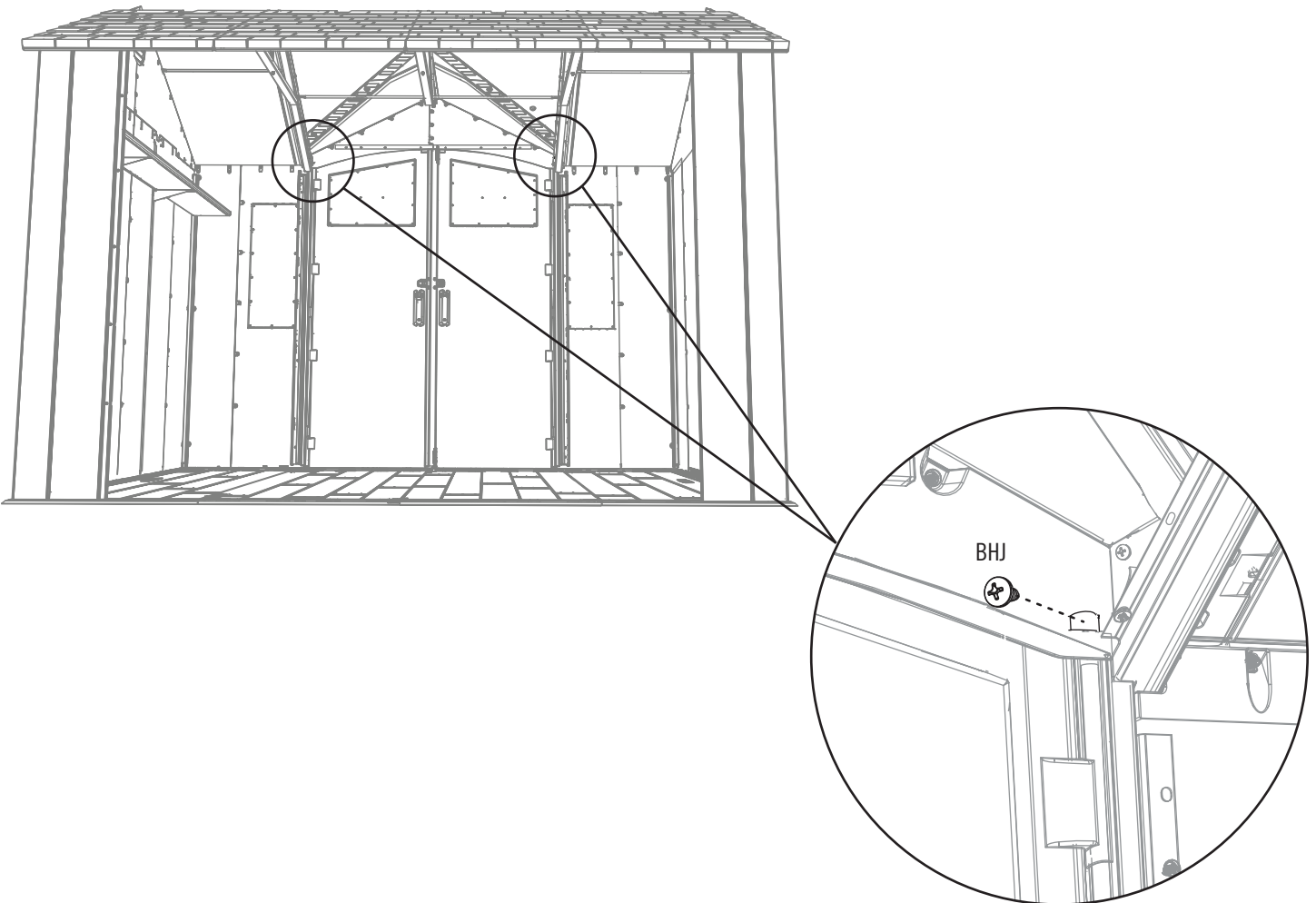

## ► SECTION 9 (CONTINUED) / SECTION 9 (SUITE) / SECCIÓN 9 (CONTINUACIÓN)

TOOLS AND HARDWARE REQUIRED / OUTILS ET QUINCAILLERIE REQUIS / INSTRUMENTAL Y HERRAJE REQUERIDOS

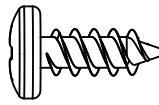

ADZ (x28)

### 9.22

- Starting at the left, secure the **Roof Caps (AGG (115), AFY (117), and AFW (116))** to the Gables, Roof Panels and each other, and to the Trusses using the hardware included.
- En commençant au côté gauche, fixer les **chapeaux (AGG (115), AFY (117), et AFW (116))** aux pignons, panneaux de toit et les uns aux autres, et aux fermes en utilisant la quincaillerie incluse.
- Empezando a la izquierda, fijar las **cumbreras (AGG (115), AFY (117), y AFW (116))** a las fachadas, los paneles de techo y las unas a las otras, y las cerchas usando el herraje incluido.

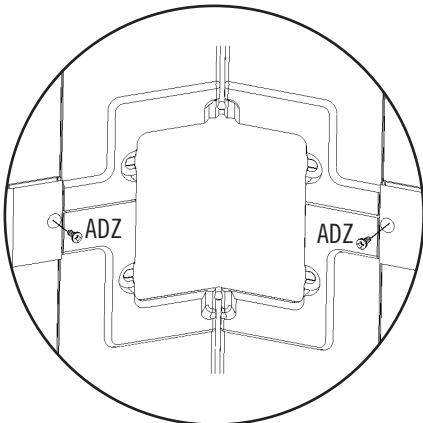
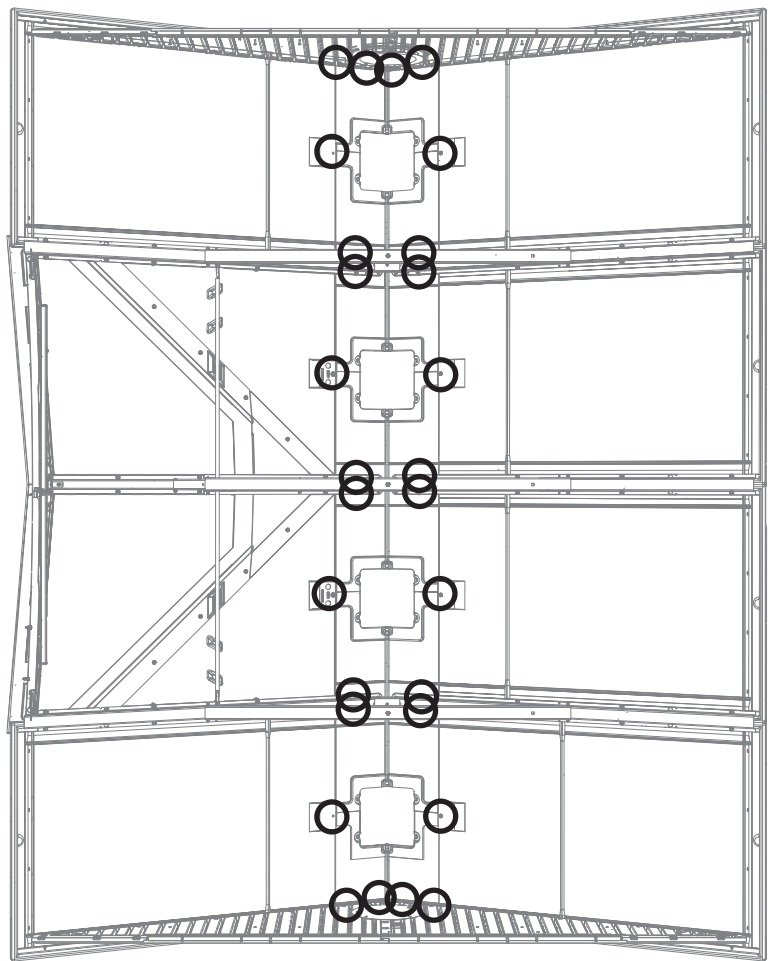
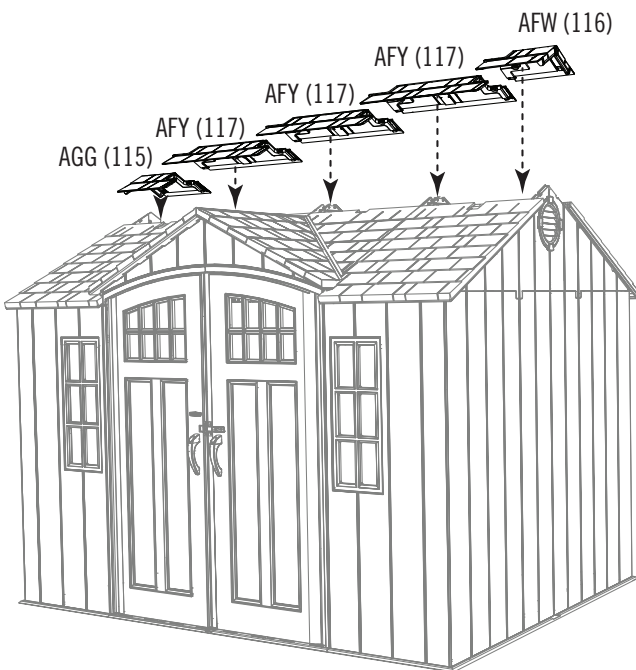

*Note: The ends of the Roof Caps overlap one another.  
Note : Les extrémités des chapeaux se chevauchent.  
Nota: Los extremos de las cumbreras se solapan.*

## ► SECTION 9 (CONTINUED) / SECTION 9 (SUITE) / SECCIÓN 9 (CONTINUACIÓN)

TOOLS AND HARDWARE REQUIRED / OUTILS ET QUINCAILLERIE REQUIS / INSTRUMENTAL Y HERRAJE REQUERIDOS

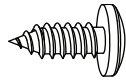

ADX (x24)

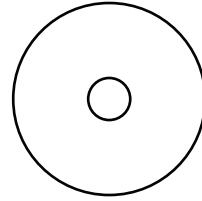

AED (x24)

### 9.23

- Fold the **Skylights (AHC)**, and attach them to the Roof using six (6) **Screws (ADX)** and **Washers (AED)** for each Skylight.
- Plier les **lucarnes (AHC)**, et fixer-les au toit à l'aide de six (6) **vis (ADX)** et **rondelles (AED)** pour chaque lucarne.
- Doblar los **tragaluzes (AHC)**, y fijarlos al tejado usando seis (6)  **tornillos (ADX)** y **rondanas (AED)** para cada tragaluz.

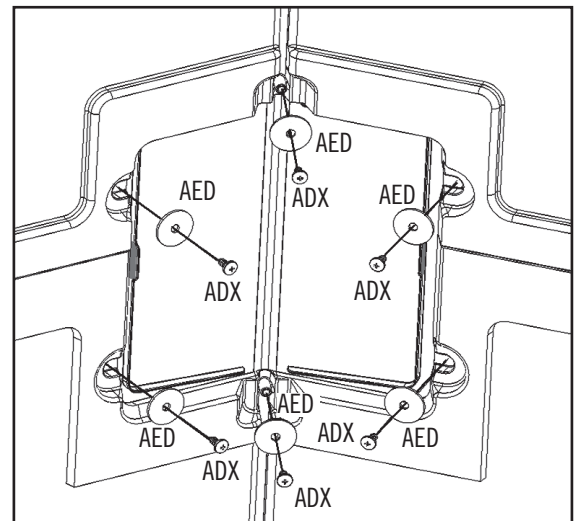
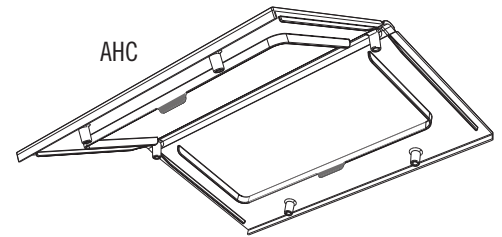
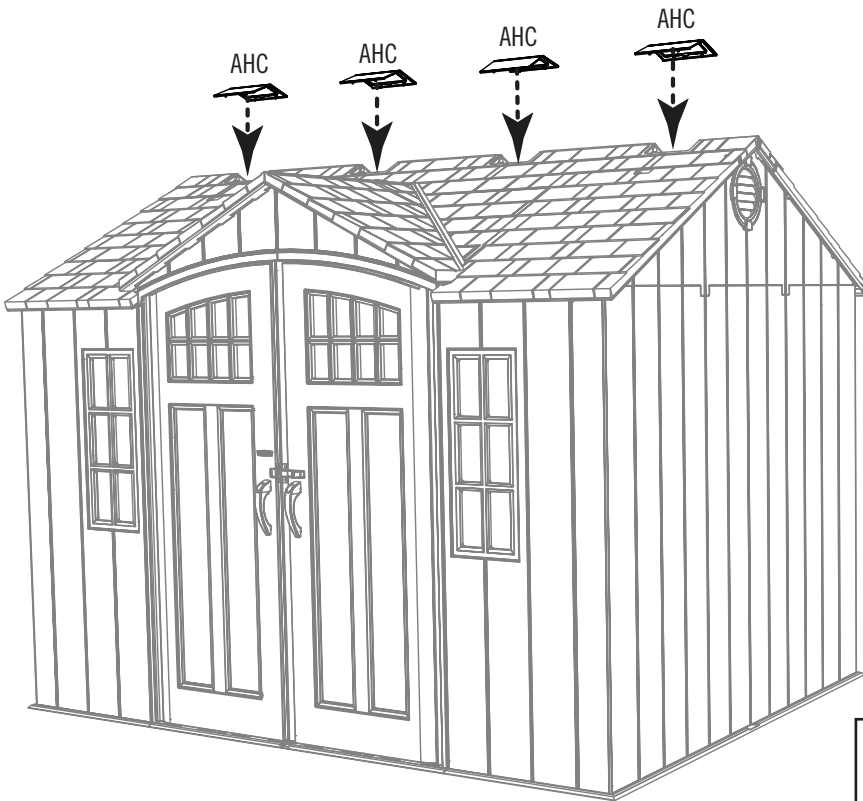

# 10

## WALL HOOK INSTALLATION / INSTALLATION DES CROCHETS MURAUX / INSTALACIÓN DE LOS GANCHOS MURALES



### HARDWARE REQUIRED / QUINCAILLERIE REQUISE / HERRAJE REQUERIDO

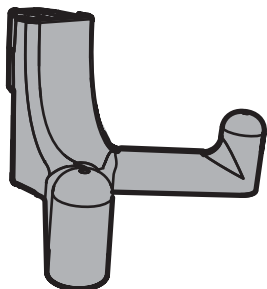

EDL (x6)



### PARTS REQUIRED / PIÈCES REQUISES / PIEZAS REQUERIDAS



### TOOLS REQUIRED (NOT INCLUDED) / OUTILS REQUIS (NON INCLUS) / INSTRUMENTAL REQUERIDO (NO INCLUIDO)





## ► SECTION 10 (CONTINUED) / SECTION 10 (SUITE) / SECCIÓN 10 (CONTINUACIÓN)

TOOLS AND HARDWARE REQUIRED / OUTILS ET QUINCAILLERIE REQUIS / INSTRUMENTAL Y HERRAJE REQUERIDOS

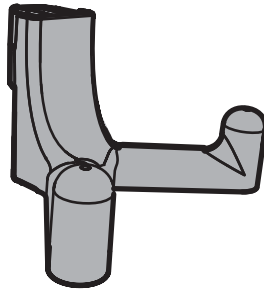



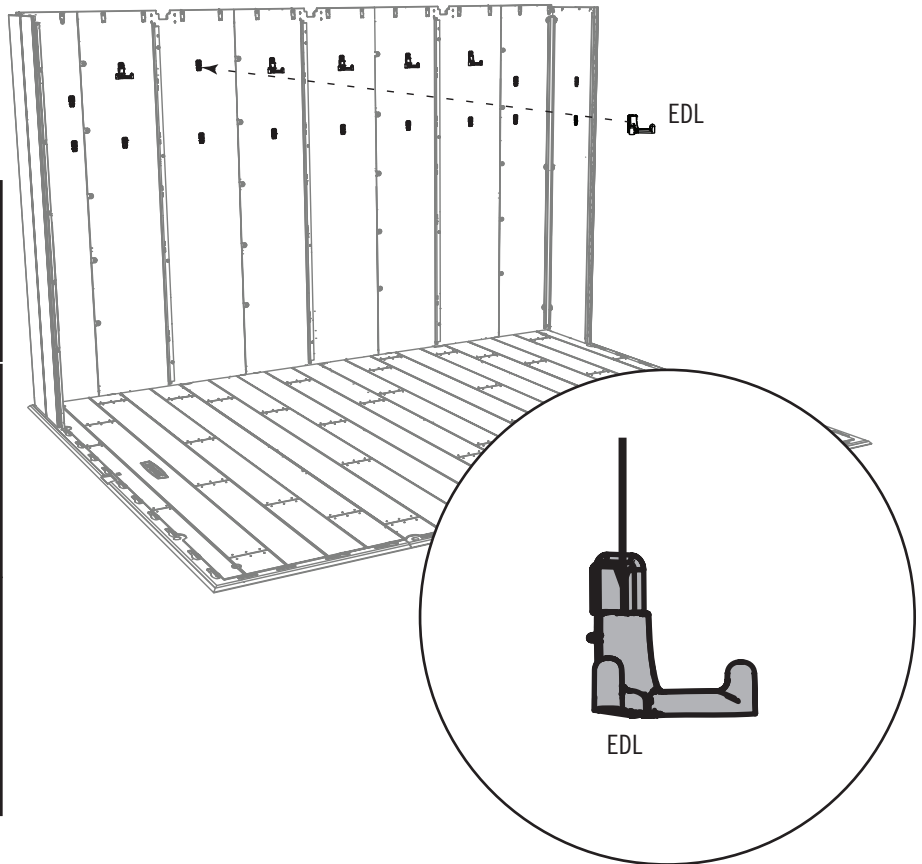

EDL (x6)

### 10.1

- Insert the six (6) **Wall Hooks (EDL)** into any of the notches in the Wall Panels (along the rear Wall). Then push downward to lock them in place.
- Insérer les six (6) **crochets muraux (EDL)** dans les encoches dans les panneaux muraux (le long du mur arrière). Ensuite, les pousser vers le bas pour bien les attacher en place.
- Insertar los seis (6) **ganchos murales (EDL)** en las muescas en los paneles murales (a lo largo del muro trasero). Entonces, empujarlos hacia abajo para fijarlos bien en su lugar.



 <b>WARNING</b>
The total weight on a wall hook should not exceed $\approx 3.2$ kg (7 lb) nor more than $\approx 14$ kg (30 lb) on a wall panel. Failure to follow this warning could result in property damage and/or personal injury.
 <b>AVERTISSEMENT</b>
Le poids total sur un crochet mural ne devrait pas excéder $\approx 3,2$ kg (7 lb) ou plus de $\approx 14$ kg (30 lb) sur un panneau mural. Le non-respect de cet avertissement peut entraîner des dommages à la propriété et/ou des blessures graves.
 <b>ADVERTENCIA</b> 
El peso total en un gancho mural no debe exceder de 7 lb (3.2 kg) ni más de 30 lb (14 kg) en un panel mural. El no seguir esta advertencia puede resultar en daños a la propiedad y/o en lesiones graves personales.

# 11

## DOOR ALIGNMENT / ALIGNEMENT DES PORTES / ALINEACIÓN DE LAS PUERTAS



### HARDWARE REQUIRED / QUINCAILLERIE REQUISE / HERRAJE REQUERIDO



### PARTS REQUIRED / PIÈCES REQUISES / PIEZAS REQUERIDAS

*Plastic Parts / Pièces en plastique / Piezas de plástico*

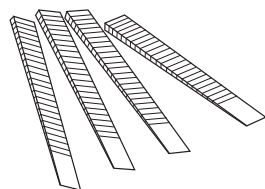

AIX (x4)



### TOOLS REQUIRED / OUTILS REQUIS / INSTRUMENTAL REQUERIDO

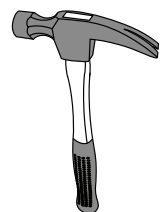

7/16 in/po  
(11 mm)

## ► SECTION 11 (CONTINUED) / SECTION 11 (SUITE) / SECCIÓN 11 (CONTINUACIÓN)

TOOLS AND HARDWARE REQUIRED / OUTILS ET QUINCAILLERIE REQUIS / INSTRUMENTAL Y HERRAJE REQUERIDOS

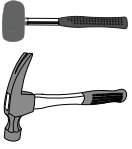

- If the Doors are not level, follow the steps on this page or the next to even them out.
- Si les portes ne sont pas niveaux l'une avec l'autre, suivre les étapes dans cette page ou la suivante pour les niveler.
- Si las puertas no están niveladas, seguir los pasos en esta página o la siguiente para nivelarlas.

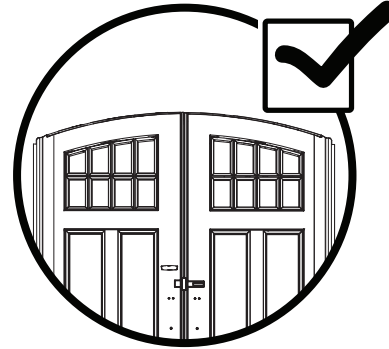
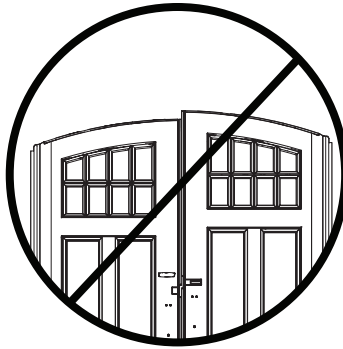
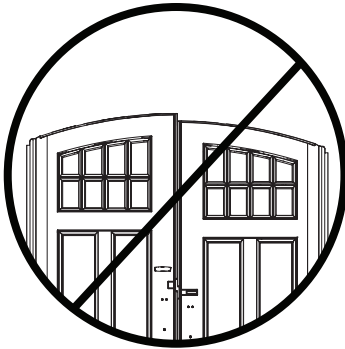

### 11.1

- If the Left Door is higher, insert a **Shim (AIX)** underneath the Floor underneath the Right Door until the Doors are the same height. If the Right Door is higher, insert a Shim underneath the Floor underneath the Left Door. **Break off any excess Shim.**
- Si la porte gauche est plus haute, insérer une **cale (AIX)** sous le plancher sous la porte droite jusqu'à ce que les portes restent à la même hauteur. Si la porte droite est plus haute, insérer une cale sous le plancher sous la porte gauche. **Détacher de l'excès des cales.**
- Si la puerta izquierda es más alta, insertar una **cuña (AIX)** debajo el piso debajo la puerta derecha hasta que las puertas queden a la misma altura. Si la puerta derecha es más alta, insertar una **cuña (EUG)** debajo el piso debajo la puerta izquierda. **Quebrantar cualquier exceso de las cuñas.**

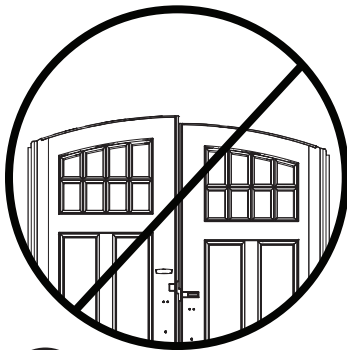

1

+

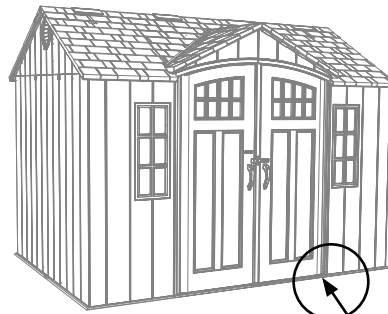

2

=



3

## ► SECTION 11 (CONTINUED) / SECTION 11 (SUITE) / SECCIÓN 11 (CONTINUACIÓN)

TOOLS AND HARDWARE REQUIRED / OUTILS ET QUINCAILLERIE REQUIS / INSTRUMENTAL Y HERRAJE REQUERIDOS



7/16 in/po  
(11 mm)

### 11.2

- Once the Doors are the same height, have one adult with the tools stand inside the shed. Close the Doors and lock them. Center the Dead Bolt by adjusting the Lock Brackets and Strike Plates.
- Une fois que les portes soient à la même hauteur, un adulte avec les outils doit attendre dans l'abri. Un autre adulte à l'extérieur de l'abri doit fermer les portes et les verrouiller. Centrer les gâches et les plaques de verrouillage par les ajuster.
- Una vez que las puertas estén a la misma altura, un adulto debe quedarse con las herramientas en mano dentro de la caseta. Otro adulto afuera de la caseta debe cerrar las puertas y cerrarlas con pestillo. Centrar el pestillo por ajustar las placas de cierre y las Placas de impacto.

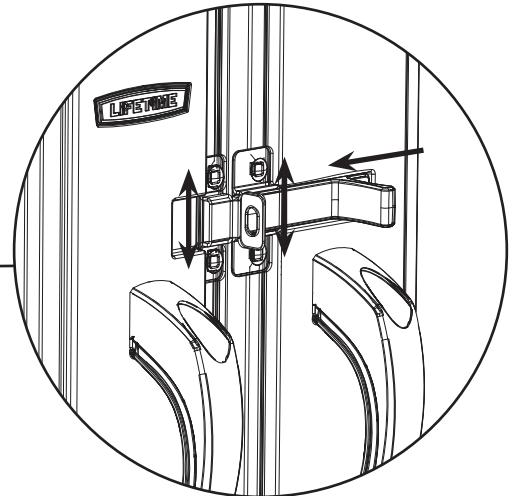
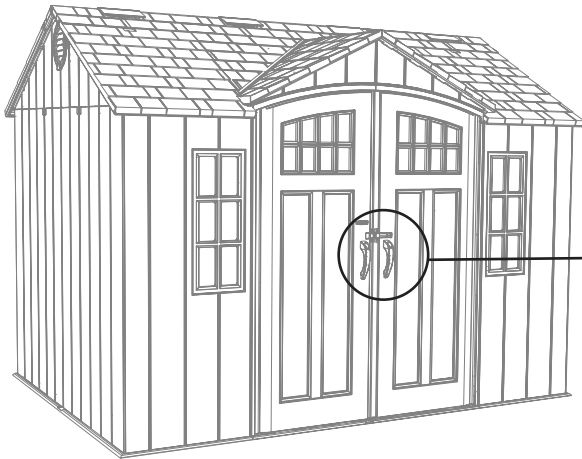

### 11.3

- Tighten the two Cap Nuts to secure the locking hardware in place.
- Serrer les deux écrous borgnes pour fixer bien la quincaillerie de verrouillage en place.
- Apretar las dos tuercas ciegas para fijar el herraje de cierre en su lugar.

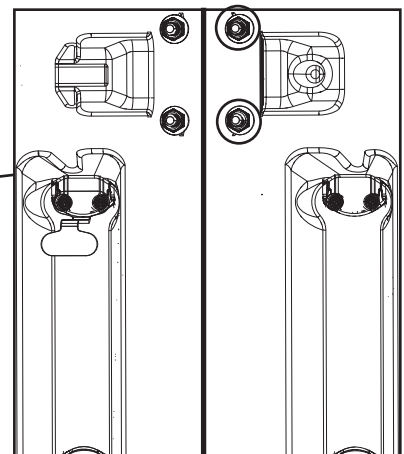
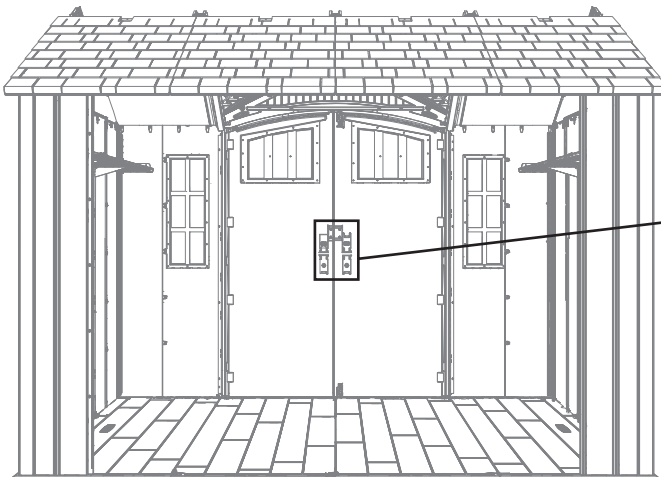

# 12

## SHED ANCHORING / ANCRAGE DE L'ABRI / ANCLAJE DE LA CASETA



### HARDWARE REQUIRED / QUINCAILLERIE REQUISE / HERRAJE REQUERIDO



### PARTS REQUIRED / PIÈCES REQUISES / PIEZAS REQUERIDAS



### TOOLS REQUIRED / OUTILS REQUIS / INSTRUMENTAL REQUERIDO

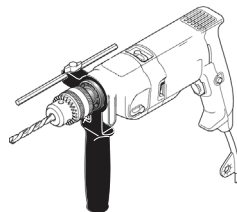

5/16" (8 mm) Wood Drill Bit  
Foret à bois de 8 mm  
Broca para madera de 8 mm



5/16" (8 mm) Masonry Drill Bit  
Foret à maçonnerie de 8 mm  
Broca para albañilería de 8 mm

## ► SECTION 12 (CONTINUED) / SECCIÓN 12 (CONTINUACIÓN) / SECTION 12 (SUITE)

FOR CONCRETE PLATFORMS / POUR LES PLATE-FORMES EN BÉTON / PARA PLATAFORMAS DE CONCRETO

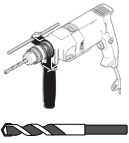

5/16 in/po  
(8 mm)



# 12.1



• To anchor your shed, you must purchase the correct anchoring hardware. **For a concrete platform**, we recommend using a hammer drill, 5/16" (8 mm) masonry bit, eight (8) 3/8" x 2" (10 mm x 5 cm) Concrete Screws and eight (8) 3/8" x 1" (10 mm x 2,5 cm) Fender Washers. **Do not exceed a 3/8" diameter screw. Refer to your local hardware store for this hardware.**

• Pour ancrer l'abri, il faut acheter la quincaillerie d'ancrage correcte. **Pour une plate-forme en béton**, nous recommandons l'utilisation d'une perceuse de percussion, un foret à maçonnerie de 8 mm, huit (8) vis d'ancrage à béton de 10 mm x 5 cm (3/8 po x 2 po) et huit (8) rondelles de protection de 10 mm x 2,5 cm (3/8 po x 1 po). **Ne pas dépasser un diamètre de 10 mm (3/8 po). Votre quincaillerie locale aura ces accessoires.**

• Para anclar la caseta, es necesario comprar el herraje de anclaje correcto. **Para una plataforma de concreto**, recomendamos el uso de un martillo perforador, broca de albañilería de 8 mm, ocho (8) tornillos de anclaje para concreto de 10 mm x 5 cm (3/8 in x 2 in) y ocho (8) rondanas de protección de 10 mm x 2,5 cm (3/8 in x 1 in). **No exceder un diámetro de 10 mm (3/8 in). Referirse a su ferretería local para obtener este herraje.**

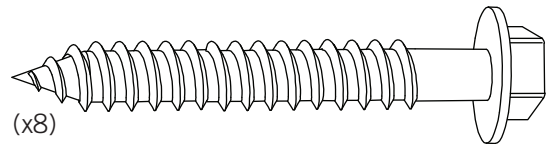
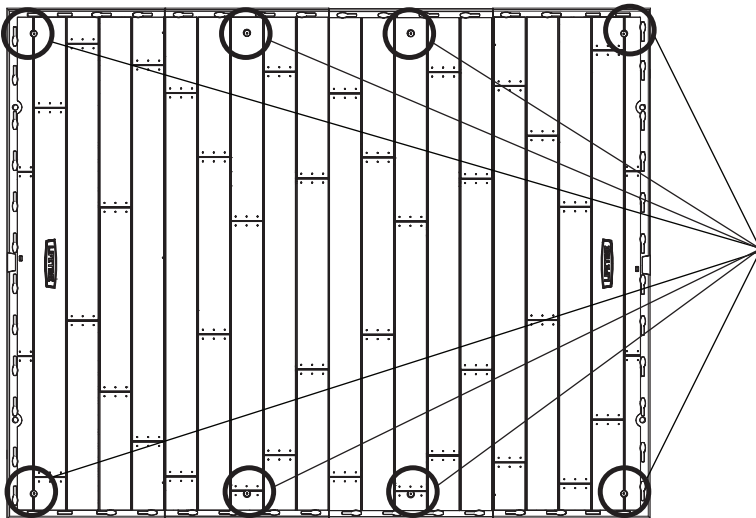

(x8)

(Not included) (No incluidos) (Pas incluses)

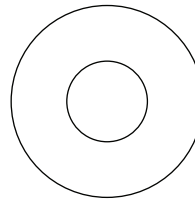

(x8)

(Not included) (Pas incluses) (No incluidas)



### WARNING / AVERTISSEMENT / ADVERTENCIA



- Failure to anchor the shed may result in property damage and/or personal injury.
- Si vous n'ancrez pas votre abri, des dommages à la propriété et/ou des blessures peuvent en résulter.
- No anclar la caseta puede resultar en daños a la propiedad y/o en lesiones personales.

## ► SECTION 12 (CONTINUED) / SECCIÓN 12 (CONTINUACIÓN) / SECTION 12 (SUITE)

FOR WOOD PLATFORMS / POUR LES PLATE-FORMES EN BOIS / PARA PLATAFORMAS DE MADERA



5/16 in/po  
(8 mm)



### 12.1



• To anchor your shed, you must purchase the correct anchoring hardware. **For a wood-framed platform**, we recommend using a drill, 5/16" (8 mm) drill bit, eight (8) 3/8" x 1 1/2" (10 mm x 4 cm) Lag Screws and eight (8) 3/8" x 1" (10 mm x 2,5 cm) Fender Washers. **Do not exceed a 3/8" diameter screw. Refer to your local hardware store for this hardware.**

• Pour ancrer l'abri, il faut acheter la quincaillerie d'ancrage correcte. **Pour une plate-forme en bois**, nous recommandons l'utilisation d'une perceuse électrique, un foret de 8 mm, huit (8) vis de retard de 10 mm x 4 cm (3/8 po x 1 1/2 po), et huit (8) rondelles de protection de 10 mm x 2,5cm (3/8 po x 1 po). **Ne pas dépasser un diamètre de 10 mm (3/8 po). Votre quincaillerie locale aura ces accessoires.**

• Para anclar la caseta, es necesario comprar el herraje de anclaje correcto. **Para una plataforma hecho de madero**, recomendamos el uso de un taladro eléctrico, una broca de 8 mm, ocho (8) tornillos para madera de 10 mm x 4 cm (3/8 in x 1 1/2 in) y ocho (8) rondanas de protección de 10 mm x 2,5 cm (3/8 in x 1 in). **No exceder un diámetro de 10 mm (3/8 in). Referirse a su ferretería local para obtener este herraje.**

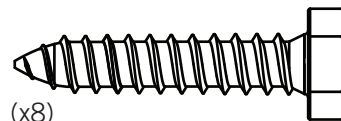
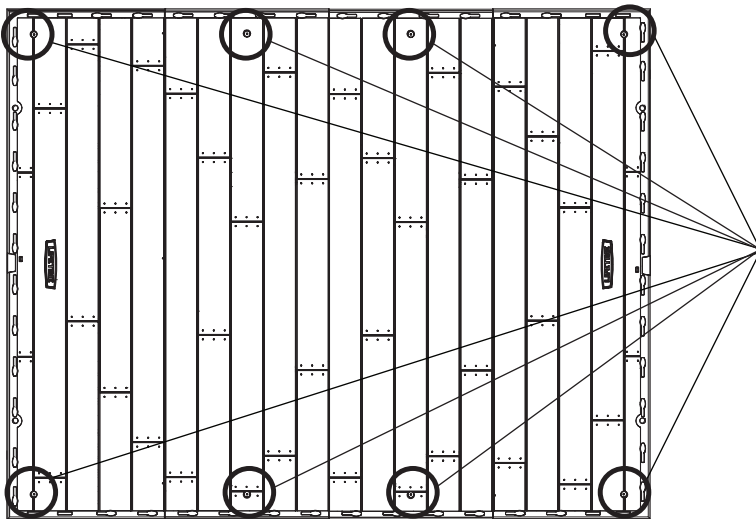

(x8)

(Not included) (No incluidos) (Pas incluses)

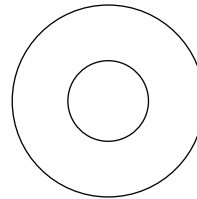

(x8)

(Not included) (Pas incluses) (No incluidas)



### WARNING / AVERTISSEMENT / ADVERTENCIA



- Failure to anchor the shed may result in property damage and/or personal injury.
- Si vous n'ancrez pas votre abri, des dommages à la propriété et/ou des blessures peuvent en résulter.
- No anclar la caseta puede resultar en daños a la propiedad y/o en lesiones personales.







A large, empty white rectangular area intended for writing notes or remarks.

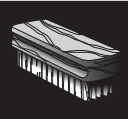

## CLEANING & CARE

**Congratulations on your Lifetime® product purchase. By following the instructions below, your new Lifetime product should provide you with years of service and enjoyment.**

The polyethylene panels are stain and solvent resistant. Most stains can be removed using a mild soap and a soft-bristled brush. Abrasive cleaning materials may scratch the plastic and are not recommended. Repair scratches or rust spots on the metal by sanding the affected area lightly; using a rust preventative spray primer; and finally, spraying with a high-gloss spray enamel paint. Avoid placing a direct heat source on or near surfaces unless using a heat barrier.

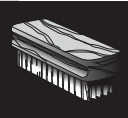

## NETTOYAGE ET ENTRETIEN

**Nous vous félicitons d'avoir acheté ce produit Lifetime®. En suivant les instructions ci-dessous, votre nouveau produit Lifetime devrait vous fournir des années de service et de plaisir.**

Les murs et les étagères en polyéthylène sont résistants aux taches et solvants de nettoyage. Pour les nettoyer, se servir d'un savon doux et d'une brosse douce. Les produits abrasifs de nettoyage risquent d'égratigner le plastique et ne sont pas recommandés. Pour réparer les égratignures ou taches de rouille sur le métal, frotter légèrement l'endroit affecté au papier de verre, puis passer une couche de produit vaporisant préventif, et, enfin, vaporiser une peinture émail ultrabrillante. Éviter de placer une source de chaleur directe sur ou près des surfaces, ou les protéger à l'aide d'une protection contre la chaleur.



## LIMPIEZA Y CUIDADO

**Felicidades por la compra de su producto Lifetime®. Al seguir las siguientes instrucciones, su nuevo producto Lifetime le brindará años de servicio y satisfacción.**

Los paneles de polietileno son resistentes a las manchas y solventes. La mayoría de las manchas puede removerse usando un jabón suave y un cepillo de cerdas suaves. Los materiales abrasivos para limpieza pueden rayar el plástico y no se recomiendan. Reparar rayones o manchas de óxido en el metal, lijando suavemente la parte afectada; usando un aerosol preventivo de óxido y finalmente, rociando con una pintura de esmalte brillante. Evitar poner una fuente de calor directa en o cerca de las superficies sin usar una barrera de calor.



## REGISTER YOUR PRODUCT ONLINE AT WWW.LIFETIME.COM

At Lifetime®, we are committed to providing innovative and quality products. While registering, you will have the opportunity to give us your feedback. Your input is valuable to us.

- You can also opt in to receive new product notifications or promotions.
- In the unlikely event of a product recall or safety modification, your registration provides the information we need to notify you directly.
- Registration is fast, easy, and completely voluntary.

### LIFETIME'S PROMISE TO YOU:

*Maintaining your privacy is our long-standing policy at Lifetime®. And you can rest assured that Lifetime® will not sell or provide your personal data to other third parties, or allow them to use your personal data for their own purposes.*

We invite you to read our privacy policy at [www.lifetime.com](http://www.lifetime.com)

**REGISTER today!**



## ENREGISTRER CE PRODUIT EN LIGNE À WWW.LIFETIME.COM

Chez Lifetime®, nous nous engageons à fournir des produits innovateurs de qualité. Lors de votre inscription, vous aurez l'occasion de nous faire parvenir vos commentaires. Votre opinion est importante pour nous.

- On peut également choisir de recevoir des avis ou des promotions dans le cadre de nouveaux produits.
- Dans l'éventualité improbable d'un rappel ou d'un avis de sécurité, l'inscription fournit les renseignements nécessaires nous permettant de communiquer avec vous.
- L'inscription est rapide, facile et complètement volontaire.

### LA PROMESSE DE LIFETIME:

*Conserver votre confidentialité est notre politique de longue date chez Lifetime®. Vous pouvez donc être rassuré par le fait que Lifetime® ne vendra pas ou ne fournira pas vos données personnelles à des tiers, et ne leur permettra pas d'utiliser vos données personnelles à leurs propres fins.*

Nous vous invitons à lire notre politique de confidentialité à [www.lifetime.com](http://www.lifetime.com) (en anglais seulement)

**ENREGISTRER CE PRODUIT aujourd'hui!**



## REGISTRAR EL PRODUCTO EN LÍNEA EN WWW.LIFETIME.COM

En Lifetime®, estamos comprometidos a ofrecer productos innovadores y de calidad. Al registrarse, usted tendrá la oportunidad de darnos su retroalimentación. Su información es valiosa para nosotros.

- También puede optar por recibir nuestras notificaciones o promociones.
- En el caso improbable de que el producto deba ser retirado del mercado o que sufra alguna modificación, su registro provee la información que necesitamos para notificarle directamente.
- El registro es rápido, fácil y completamente voluntario.

### LA PROMESA DE LIFETIME® PARA USTED:

*Mantener privacidad es nuestra política permanente en Lifetime®. Y puede estar seguro que Lifetime® no venderá ni dará datos personales a terceros, ni les permitirá usar datos personales para sus propios fines.*

Lo invitamos a leer nuestra política de privacidad en [www.lifetime.com](http://www.lifetime.com) (sólo en inglés)

**¡REGISTRARSE hoy mismo!**



## 10-YEAR LIMITED FACTORY WARRANTY

**THE MANUFACTURER RESERVES THE RIGHT TO MAKE SUBSTITUTIONS TO WARRANTY CLAIMS IF PARTS ARE UNAVAILABLE OR OBSOLETE.**

Lifetime Lawn and Garden products are warranted to the original purchaser to be free from defects in material or workmanship for a period of 10 years from the date of original retail purchase. The word “defects” is defined as imperfections that impair the use of the product. Defects resulting from misuse, abuse or negligence will void this warranty. This warranty does not cover defects due to improper installation, alteration or accident. Lifetime recommends that no modifications be made to this product. This warranty does not cover damage caused by vandalism, rusting, “acts of nature”, natural disasters, normal wear and tear, or any other event beyond the control of the manufacturer.

This warranty is nontransferable and is expressly limited to the repair or replacement of defective products. If the product is defective within the terms of this warranty, Lifetime Products, Inc. will repair or replace defective parts at no cost to the purchaser. Shipping charges to and from the factory or distribution center are not covered and are the responsibility of the purchaser. Labor charges and related expenses for removal, installation or replacement of the product or its components are not covered under this warranty.

This warranty does not cover scratching, scuffing, or other cosmetic damage of the product that may result from normal usage. In addition, defects resulting from intentional damage, negligence, or unreasonable use will void this warranty / are not covered by this warranty.

Liability for incidental or consequential damages is excluded to the extent permitted by law. All merchandise is sold on this condition, and no representative of the company may waive or change this policy. This product is not intended for institutional or commercial use; Lifetime Products, Inc. does not assume any liability for such use. Institutional or commercial use will void the warranty.

This warranty is expressly in lieu of all other warranties, expressed or implied, including warranties of merchantability or fitness for use to extent permitted by Federal and state law. Neither Lifetime Products, Inc., nor any representative assumes any other liability in connection with this product. This warranty gives you specific legal rights, and you may also have other rights which vary from state to state.

Our goods come with guarantees that cannot be excluded under the Australian Consumer Law. You are entitled to a replacement or refund for a major failure and for compensation for any other reasonably foreseeable loss or damage. You are also entitled to have the goods repaired or replaced if the goods fail to be of acceptable quality and the failure does not amount to a major failure.

**ALL WARRANTY CLAIMS MUST BE ACCOMPANIED BY A SALES RECEIPT.  
REPORT PRODUCT DEFECTS IN WRITING TO:**

LIFETIME PRODUCTS, INC.,  
PO Box 160010  
Freeport Center, Bldg. D-12  
Clearfield, UT 84016-0010

For online warranty claims, please visit: [www.lifetime.com/warranty](http://www.lifetime.com/warranty)  
Warranty Department: (800) 225-3865

**FOR INTERNATIONAL WARRANTY:**

All warranty claims must be accompanied by a sales receipt. Report product defects in writing to your regional sales support representative. Please include your dated sales receipt and photographs of damaged parts.

To Identify the representative for your region, please visit: [www.lifetime.com/international](http://www.lifetime.com/international)



## GARANTIE DE FABRICATION LIMITÉE DE 10 ANS

**LIFETIME® PRODUCTS, INC. RÉSERVE LE DROIT DE FAIRE DES SUBSTITUTIONS EN CAS DE RECOURS EN GARANTIE SI LES PIÈCES NE SONT PAS DISPONIBLES OU SONT OBSOLÈTES.**

L'acheteur d'origine des produits pour pelouses et jardins de Lifetime bénéficie d'une garantie contre toute défectuosité de matériel et de fabrication pour une période de 10 ans à compter de la date d'achat. On entend par « défaut » une imperfection qui nuit à l'utilisation du produit. Tout défaut découlant d'une mauvaise utilisation, d'un abus ou d'une négligence a pour effet d'annuler cette garantie. Cette garantie ne couvre pas les défauts attribuables à une installation inadéquate, une altération ou un accident. Lifetime recommande de ne pas apporter de modifications à ce produit. Cette garantie ne couvre pas les dommages causés par le vandalisme, la corrosion par la rouille, les cas de « force majeure », les catastrophes naturelles, la détérioration et l'usure normales et tout autre événement indépendant de la volonté du fabricant.

Cette garantie n'est pas transférable et se limite expressément à la réparation ou au remplacement d'un produit défectueux. Si le produit est défectueux au sens de cette garantie, Lifetime Products, Inc. réparera ou remplacera les pièces défectueuses sans frais pour l'acheteur. Les frais d'expédition en partance ou en provenance de l'usine ou du centre de distribution ne sont pas couverts et incombent à l'acheteur. Les coûts relatifs à la main-d'œuvre et les autres frais liés au retrait, à l'installation ou au remplacement du produit ou de ses composants ne sont pas couverts par cette garantie.

Cette garantie ne couvre pas les rayures, les égratignures ou autres dommages esthétiques du produit découlant d'un usage normal. De plus, tout défaut découlant d'un dommage volontaire, de négligence ou d'un usage déraisonnable annule cette garantie et n'est pas couvert par cette garantie.

Dans la mesure permise par la loi, la société n'est pas responsable des dommages indirects ou accessoires. Toute marchandise est vendue à cette condition et aucun représentant de la société ne peut renoncer à l'application de cette politique ou la modifier. Ce produit n'est pas destiné à des fins institutionnelles ou commerciales; Lifetime Products, Inc. n'assume aucune responsabilité à cet égard. Toute utilisation institutionnelle ou commerciale annule la garantie.

La présente garantie remplace expressément toute autre garantie, expresse ou implicite, y compris les garanties de qualité marchande ou d'adaptation à un usage particulier dans la mesure permise par les lois du pays ou de l'État. Ni Lifetime Products, Inc. ni aucun de ses représentants n'assument une quelconque responsabilité en lien avec ce produit. Cette garantie vous donne des droits juridiques précis et vous pourriez également avoir d'autres droits selon l'État ou la province.

La garantie qui accompagne nos produits ne peut être exclue en vertu de la loi sur la protection du consommateur de l'Australie. Le client a droit à un remplacement ou à un remboursement en cas de bris majeur et pour toute autre perte ou dommage raisonnablement prévisible. Le client a aussi droit à ce que les produits soient réparés ou remplacés si un bris survient et rend la qualité inacceptable sans pour autant être qualifiable de bris majeur.

**TOUTE RÉCLAMATION EN VERTU DE LA GARANTIE DOIT ÊTRE ACCOMPAGNÉE D'UN REÇU DE VENTE.  
SIGNALEMENT ÉCRIT DE TOUT PRODUIT DÉFECTUEUX:**

LIFETIME PRODUCTS, INC.,  
PO Box 160010  
Freeport Center, Bldg. D-12  
Clearfield, UT 84016-0010

Pour effectuer en ligne une réclamation sous garantie, consultez cette adresse : [www.lifetime.com/warranty](http://www.lifetime.com/warranty)  
Service de la garantie : (800) 225-3865

### **GARANTIE INTERNATIONALE:**

Toute réclamation en vertu de la garantie doit être accompagnée d'un reçu de vente. Veuillez signaler par écrit tout produit défectueux au représentant du soutien aux ventes de votre région. Veuillez inclure le reçu de vente daté ainsi que des photographies des pièces endommagées.

Pour connaître le représentant de votre région, veuillez consulter le : [www.lifetime.com/international](http://www.lifetime.com/international)



## GARANTÍA DE FÁBRICA LIMITADA POR 10 AÑOS

### **EL FABRICANTE SE RESERVA EL DERECHO DE HACER SUSTITUCIONES EN LOS ELEMENTOS REEMPLAZADOS BAJO GARANTÍA SI LAS PIEZAS NO ESTÁN DISPONIBLES O SON OBSOLETAS.**

El comprador original recibe una garantía de que los productos de césped y jardín de Lifetime están libres de defectos de material o mano de obra durante un período de 10 años a partir de la fecha de compra original al por menor. La palabra “defectos” se define como imperfección que imposibilita el uso del producto. Los defectos ocasionados por el mal uso, el abuso o la negligencia anularán esta garantía. Esta garantía no cubre los defectos debidos a una instalación incorrecta, una alteración o un accidente. Lifetime recomienda que no se realicen modificaciones en este producto. Esta garantía no cubre los daños causados por vandalismo, oxidación, “actos de la naturaleza”, desastres naturales, desgaste normal o cualquier otro evento fuera del control del fabricante.

Esta garantía no es transferible y se limita expresamente a la reparación o reemplazo de productos defectuosos. Si el producto resulta defectuoso dentro de los términos de esta garantía, Lifetime Products, Inc. reparará o reemplazará las piezas defectuosas sin costo alguno para el comprador. Los gastos de envío hacia y desde la fábrica o el centro de distribución no están cubiertos y son la responsabilidad del comprador. La mano de obra y los gastos relacionados por la remoción, la instalación o la sustitución del producto o sus componentes no están cubiertos por esta garantía.

Esta garantía no cubre los rayones, los raspones ni otros daños superficiales del producto que pueden resultar del uso normal. Asimismo, los defectos resultantes de daños intencionales, negligencia o uso indebido anularán o no están cubiertos por esta garantía.

Se excluye la responsabilidad por daños imprevistos o derivados en la medida en que lo permita la ley. Toda la mercancía se vende bajo estas condiciones y ningún representante de la empresa puede renunciar a ni cambiar esta política. Este producto no está destinado para uso institucional o comercial; Lifetime Products, Inc. no asume ninguna responsabilidad por dicho uso. El uso institucional o comercial anulará la garantía.

Esta garantía sustituye expresamente cualquier otra garantía, expresa o implícita, incluidas las garantías de comercialización o idoneidad para su uso en la medida permitida por la ley federal y estatal. Ni Lifetime Products, Inc., ni ningún representante asume ninguna otra responsabilidad en relación con este producto. Esta garantía le otorga derechos legales específicos y usted también puede tener otros derechos que varían de un estado a otro.

Nuestros productos vienen con garantías que no se pueden excluir bajo la Ley Australiana del Consumidor. Usted tiene derecho a recibir un reemplazo o reembolso por un fallo grave y compensación por cualquier otra pérdida o daño razonablemente previsible. También tiene derecho a la reparación o el reemplazo de los bienes si los bienes no son de calidad aceptable y el fallo no supone un fallo grave.

### **TODOS LOS RECLAMOS DE GARANTÍA DEBEN ESTAR ACOMPAÑADOS POR UN RECIBO DE COMPRA. REPORTE LOS DEFECTOS DEL PRODUCTO POR ESCRITO A:**

LIFETIME PRODUCTS, INC.,  
PO Box 160010  
Freeport Center, Bldg. D-12  
Clearfield, UT 84016-0010

Para realizar reclamos de garantía por internet, visite: [www.lifetime.com/warranty](http://www.lifetime.com/warranty).  
Departamento de Garantías: (800) 225-3865

### **PARA LA GARANTÍA INTERNACIONAL:**

Todos los reclamos de garantía deben estar acompañados por un recibo de compra. Reporte los defectos del producto por escrito a su representante regional de apoyo de ventas. Por favor, incluya su recibo de compra con la fecha y fotografías de las piezas dañadas.

Para identificar al representante de su región, por favor visite: [www.lifetime.com/international](http://www.lifetime.com/international)

### **GARANTIA NO VÁLIDA EN MÉXICO**



**ENHANCE YOUR LIFETIME® PURCHASE BY ADDING ACCESSORIES OR OTHER GREAT PRODUCTS**

*To purchase accessories or other Lifetime® products, visit us at:*

***www.lifetime.com***

*Or call: 1-800-424-3865*

**AMÉLIORER VOTRE ACHAT LIFETIME® EN AJOUTANT DES ACCESSOIRES OU DES AUTRES PRODUITS**

*Pour acheter des accessoires ou d'autres produits Lifetime®, nous rendre visite à :*

***www.lifetime.com***

*Ou composer le 1-800-424-3865*

**MEJORAR SU COMPRA LIFETIME® Y AÑADIR ACCESORIOS U OTROS PRODUCTOS EXCELENTES**

*Para comprar accesorios u otros productos Lifetime® EUA, visítenos en:*

***www.lifetime.com***

*O marcar al: 1.800.424.3865*



[www.lifetime.com](http://www.lifetime.com)

