

**IMPORTANT: PLEASE REGISTER YOUR STONE GARDEN LIFESTYLE PRODUCT AFTER ASSEMBLY**



Affix Serial Number  
HERE

Using the unique serial number, simply register your product using the QR code above.

Customer Service: Call: +44 (0) 1889 272 056

## PLEASE READ THIS DOCUMENT FULLY PRIOR TO STARTING ASSEMBLY PROCEDURE

The objective of this instruction is to illustrate the recommended assembly sequence for this product, any deviation from this will be the sole responsibility of whoever carries out the assembly.

### IMPORTANT: IT IS ADVISABLE THAT THE PRODUCT IS ASSEMBLED AT, OR AS CLOSE AS POSSIBLE TO WHERE IT WILL BE FINALLY LOCATED

Ensure there is adequate clearance where the product is to be located:

Exterior dimensions including overhang (W x D x H)	1610 x 860 x 920mm
Footprint dimensions (W x D)	1600 x 860mm
Clearance required for lid to open (W x H)	Lid open outwards 1600 x 1710mm

### TWO PERSON ASSEMBLY

Most procedures will not require two people but it may be easier to have assistance.



### PERSONAL PROTECTION EQUIPMENT

We advise appropriate personal protective equipment is worn during assembly including eye protection and gloves.



### CARING FOR YOUR HEX LIVING PRODUCT

Your **Stone Garden Lifestyle** product is designed to stand the test of time, which is why we're happy to offer a 25 year warranty on our products. With zero maintenance required, simply assemble your **Stone Garden Lifestyle** product and enjoy putting it to great use in your garden.

Periodically, you might want to give your product a clean, these simple care tips are not essential to the performance of your product:

- Remove surface dirt with plain water using a jet wash or sponge, the coating on our products will ensure dirt or mud simply wipes away.
- Periodically clear the lid of fallen leaves.
- NOTE: during the summer months, high temperature might arise in the interior.
- To prevent damage in wet and windy weather conditions, make sure the product is secured in a storm-proof manner and the lid is locked.

### PRODUCT REGISTRATION

**IMPORTANT:** Prior to assembly, please ensure you have registered your **Stone Garden Lifestyle** product using the unique serial number found on the cover of this document, please visit <https://bit.ly/StoneGardenWarranty> to register your product and access the 25 year warranty and online support.

# Assembly Guide

**ENSURE ALL ITEMS LISTED ARE PRESENT PRIOR TO STARTING ASSEMBLY PROCEDURE**

SCALE OF ITEMS WILL VARY TO AID VISUAL IDENTIFICATION

Part Ref: 0249-01  
Qty: x2

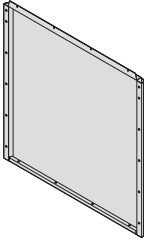

Part Ref: 0249-02  
Qty: x1

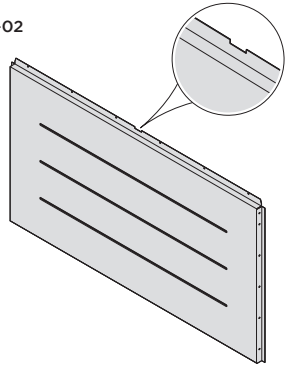

Part Ref: 0249-22  
Qty: x1

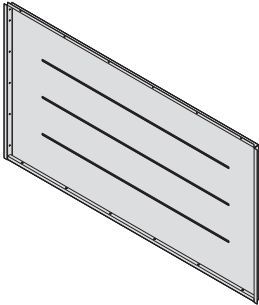

Part Ref: 0249-03  
Qty: x1

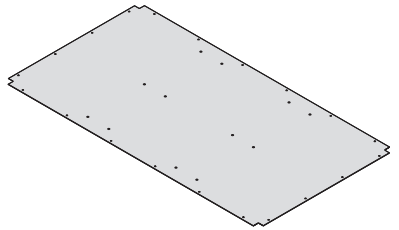

Part Ref: 0249-04  
Qty: x1

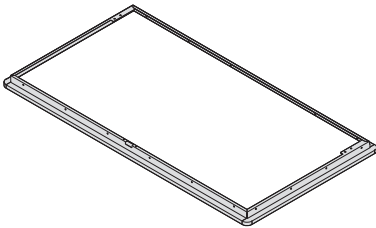

Part Ref: 0249-05  
Qty: x1

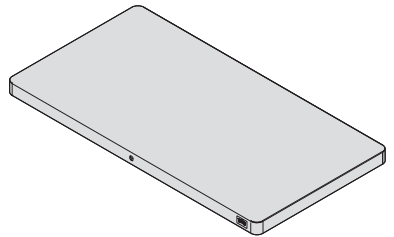

# Assembly Guide

**ENSURE ALL ITEMS LISTED ARE PRESENT PRIOR TO STARTING ASSEMBLY PROCEDURE**

SCALE OF ITEMS WILL VARY TO AID VISUAL IDENTIFICATION

Part Ref: 0249-10  
Qty: x1

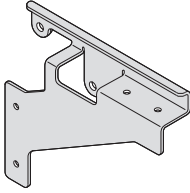

Part Ref: 0249-11  
Qty: x1

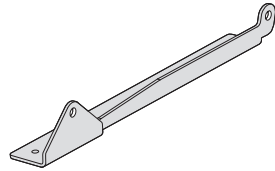

Part Ref: 0249-12  
Qty: x1

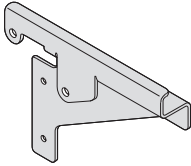

Part Ref: 0249-09  
Qty: x1

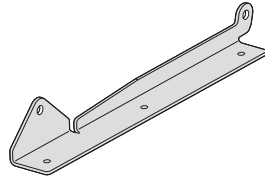

Part Ref: 0249-26  
Qty: x2

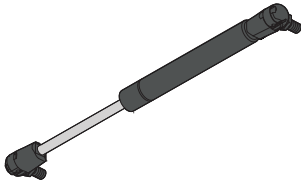

Part Ref: 0249-16  
Qty: x4

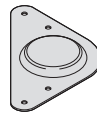

Part Ref: 0249-19  
Qty: x1

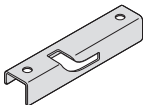

Part Ref: 0249-23  
Qty: x1

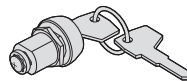

THIS PART IS NOT REQUIRED



# Assembly Guide

**ENSURE ALL ITEMS LISTED ARE PRESENT PRIOR TO STARTING ASSEMBLY PROCEDURE**

SCALE OF ITEMS WILL VARY TO AID VISUAL IDENTIFICATION

Part Ref: 0249-24

Qty: x1

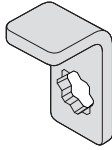

Part Ref: 0249-25

Qty: x1

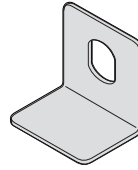

Part Ref: 0204-66

Qty: x2



Part Ref: 0249-05-03

Qty: x2



## 1200L FIXING KIT: 0249-27

Part Ref: 0249-27-01  
No.5 x 12mm Pan Head Pozi  
Qty: x52

FK1



Part Ref: 313-0009Z  
No.8 x 13mm Eco Fix  
Qty: x18

FK6



Part Ref: 0262-16  
M8 x 20mm Button Head Screw  
Qty: x2

FK2



Part Ref: 0203-54  
M8 Serrated Flange Nut  
Qty: x4

FK7



Part Ref: 0262-17  
8.3mm Nylon Washer  
Qty: x2

FK3



Part Ref: 0203-52  
M4 x 10mm Roofing Bolt  
Qty: x23

FK8



Part Ref: 0262-18  
M8 Nyloc Nut  
Qty: x2

FK4



Part Ref: 0203-55  
M4 Serrated Flange Nut  
Qty: x28

FK9



Part Ref: 0262-19  
M4 x 25mm Cap Screw  
Qty: x2

FK5



# Assembly Guide

## ASSEMBLY STAGE 1

LOCATE AND LOOSELY ATTACH SIDE PANELS 0249-01 TO BACK PANEL 0249-22.

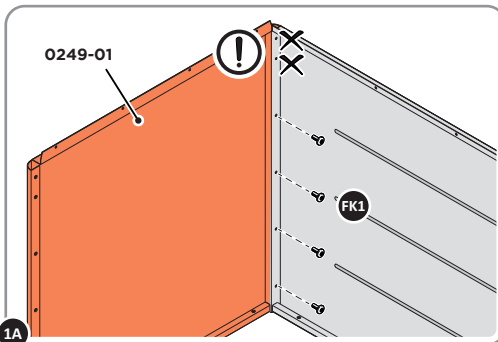
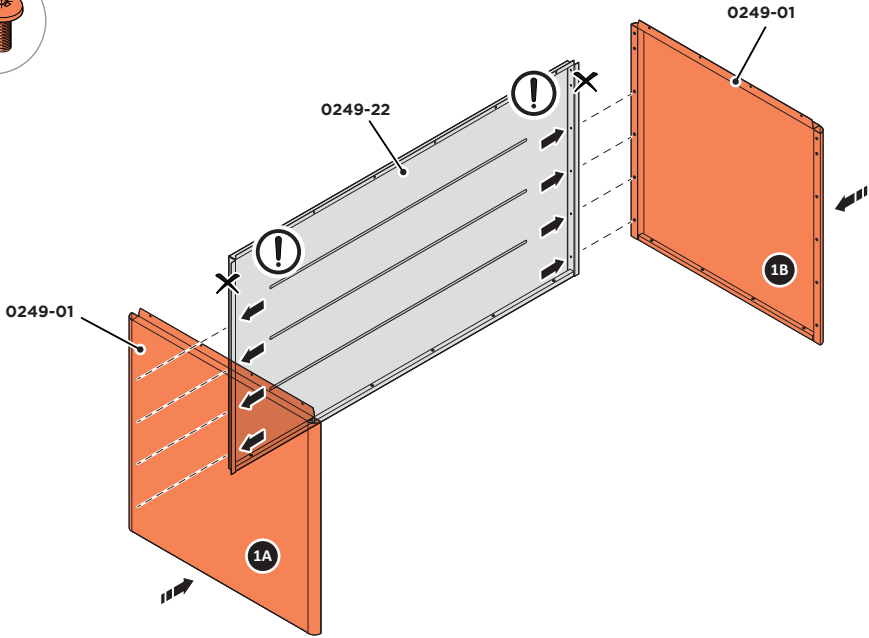

LOCATE AND LOOSELY ATTACH END PANELS TO BACK PANEL.  
**IMPORTANT: ONLY ATTACH AT (x4) FIXING POINTS INDICATED AT THIS STAGE.**

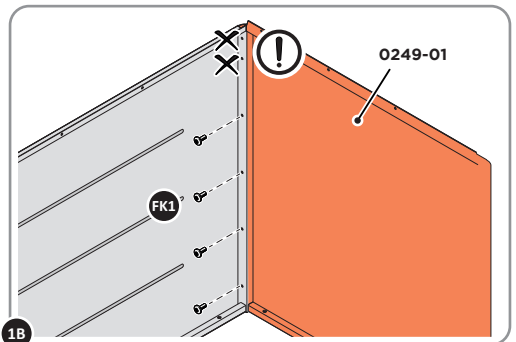

**NOTE: IGNORE THE TOP TWO HOLES, THESE ARE NEEDED FOR STAGE 10.**

# Assembly Guide

## ASSEMBLY STAGE 2

LOCATE AND LOOSELY ATTACH FLOOR PANEL 0249-03 TO BACK PANEL.

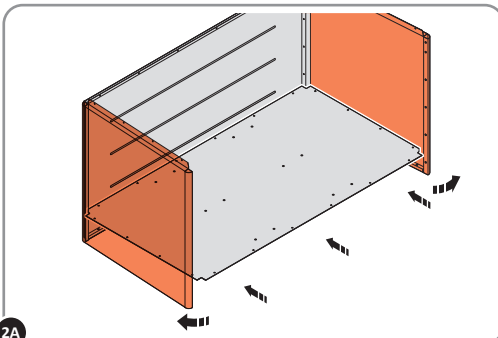
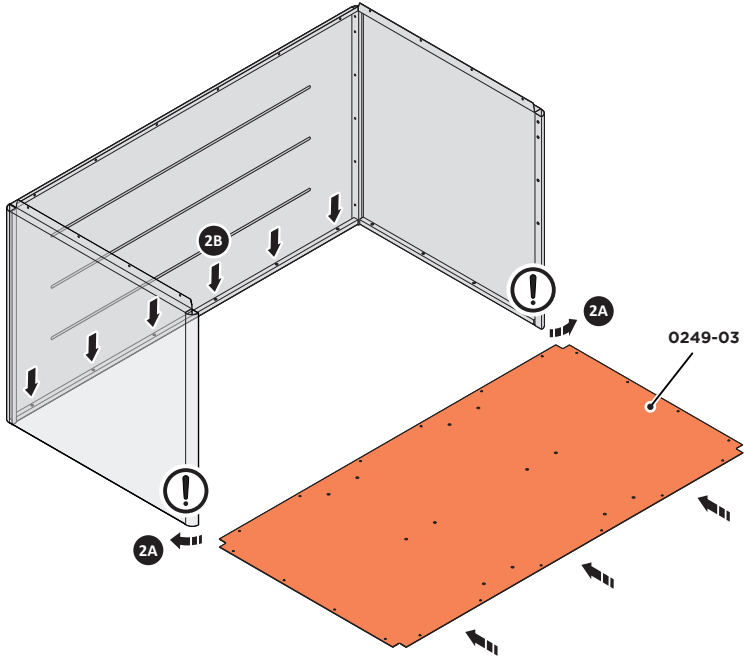

**NOTE:** SLIGHT OUTWARD ADJUSTMENT OF SIDE PANELS MAYBE REQUIRED. LOCATE FLOOR PANEL AND CAREFULLY POSITION BETWEEN SIDE PANELS.

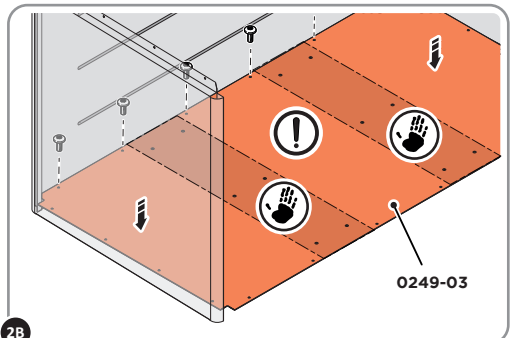

**NOTE:** ONCE LOWERED INTO POSITION, LOOSELY ATTACH AT (x6) LOCATIONS. **NOTE:** IF APPLYING BODY WEIGHT TO FLOOR, ONLY USE AREAS INDICATED ABOVE, WHICH HAVE EXTRA STRENGTH AND SUPPORT.

# Assembly Guide

## ASSEMBLY STAGE 3

LOCATE AND LOOSELY ATTACH FRONT PANEL 0249-02, AND SECURE FLOOR PANEL.

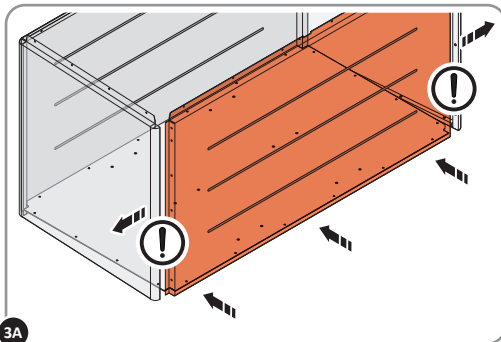
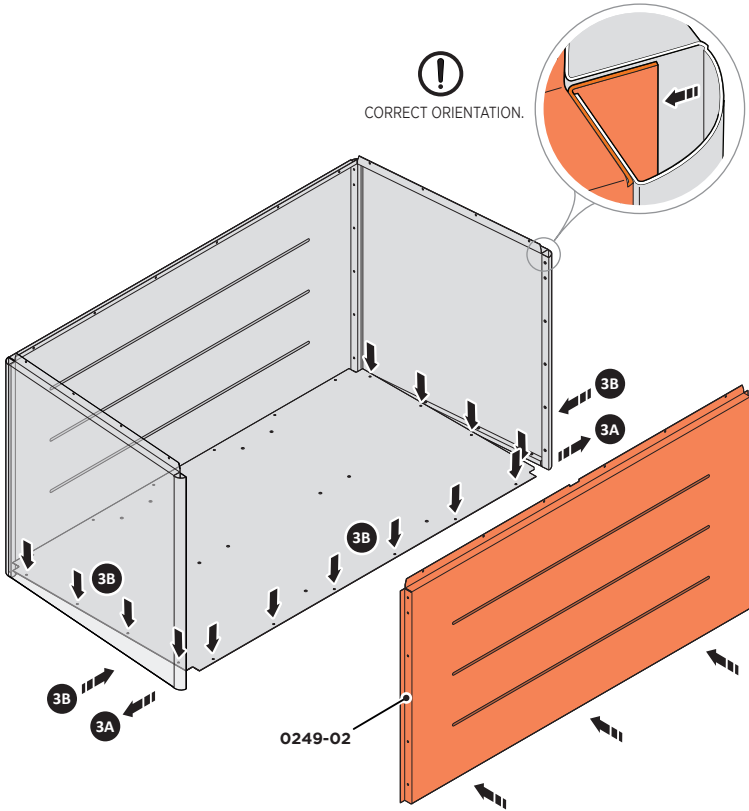

**NOTE:** SLIGHT OUTWARD ADJUSTMENT OF SIDE PANELS REQUIRED. LOCATE FRONT PANEL AND CAREFULLY POSITION BETWEEN SIDE PANELS. THE BOTTOM FRONT PANEL SLIDES UNDERNEATH FLOOR PANEL.

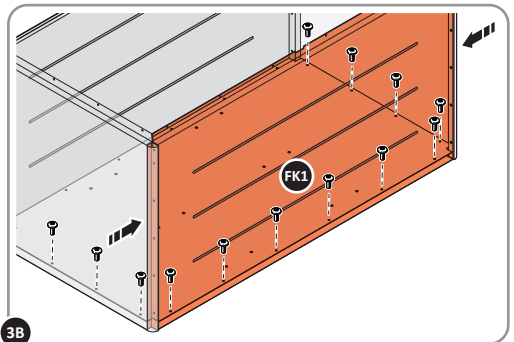

**NOTE:** INWARD ADJUSTMENT OF SIDE PANELS REQUIRED, SECURE ALL THREE PANELS TO BASE, AT LOCATIONS INDICATED ABOVE.



## ASSEMBLY STAGE 4

SECURE FRONT PANEL TO SIDE PANELS.

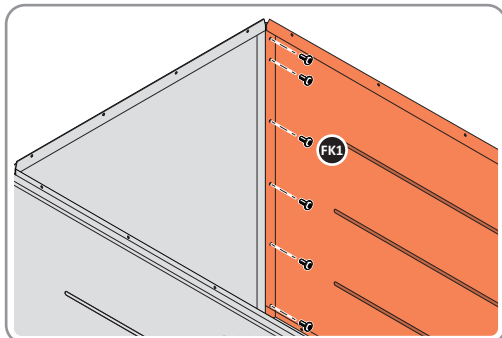
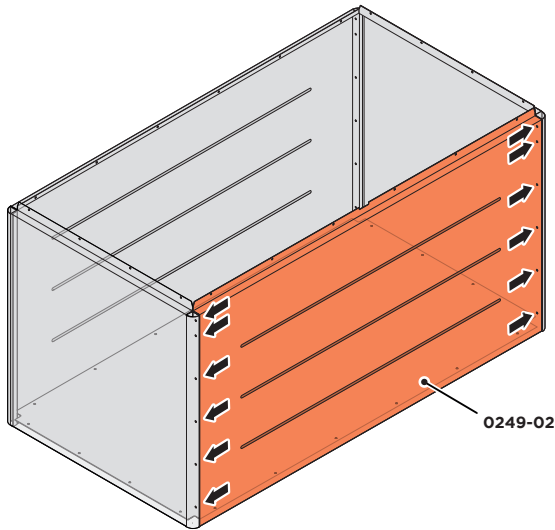

SECURE PANELS, AT LOCATIONS INDICATED ABOVE.



### IMPORTANT

ADJUST ALL COMPONENTS FOR BEST POSSIBLE FIT AND TIGHTEN ALL FASTENERS.

ONCE ALL FASTENERS HAVE BEEN CHECKED AND ARE SECURE PROCEED ONTO STAGE 5.

**NOTE:** CHECK ALL PANELS FOR ALIGNMENT AND FULL TIGHTEN ALL FK1 SCREWS.

# Assembly Guide

## ASSEMBLY STAGE 5

LOCATE AND SECURE FRAME 0249-04.

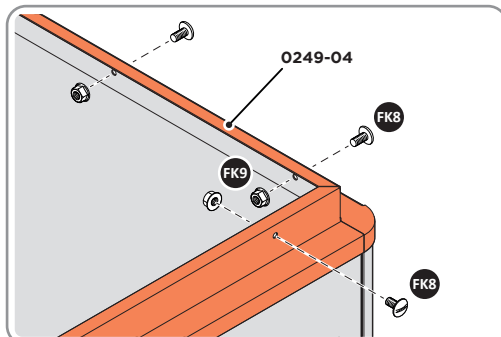
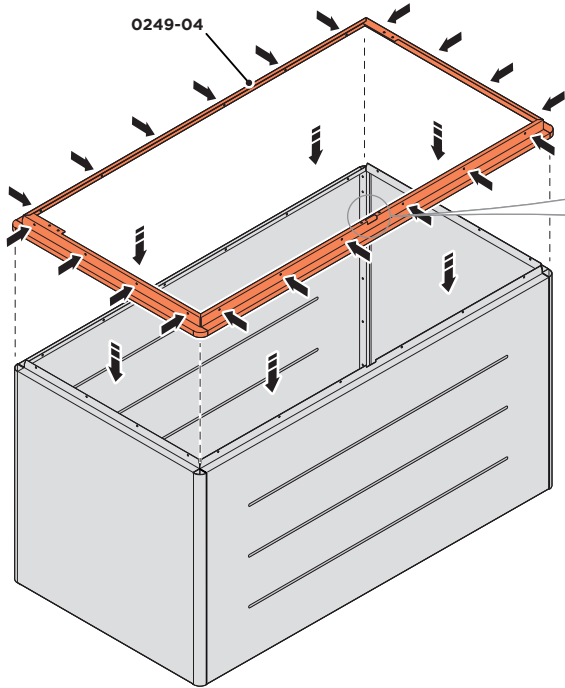

NOTE: MAKE SURE THE LOCK CUTAWAY IS IN THE CORRECT ORIENTATION. LOCATE AND SECURE FRAME 0249-04, AT LOCATIONS INDICATED ABOVE.

## ASSEMBLY STAGE 6

LOCATE AND SECURE CATCH PLATE 0249-19.

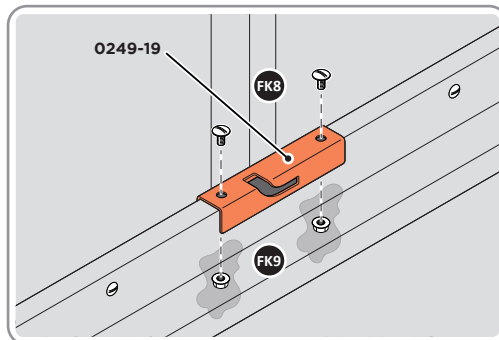
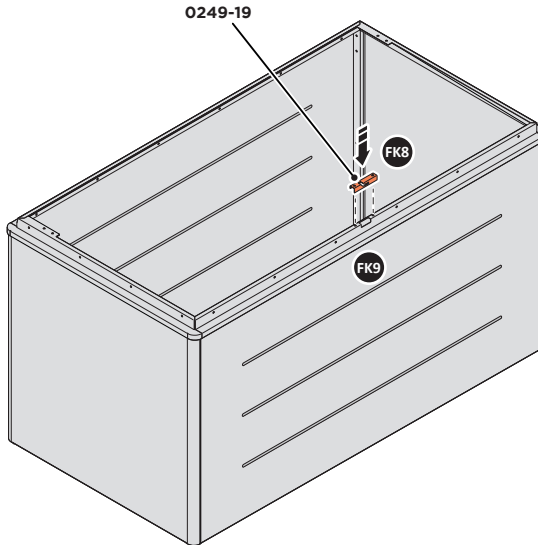

**NOTE:** MAKE SURE THE CATCH PLATE IS IN THE CORRECT ORIENTATION. LOCATE AND SECURE PLATE 0249-19, AT LOCATIONS INDICATED ABOVE.

# Assembly Guide

## ASSEMBLY STAGE 7

ROTATE BOX ON TO IT'S SIDE. SECURE BOX FEET 0249-16.

**NOTE:** USE A SCRATCH-RESISTANCE SURFACE.

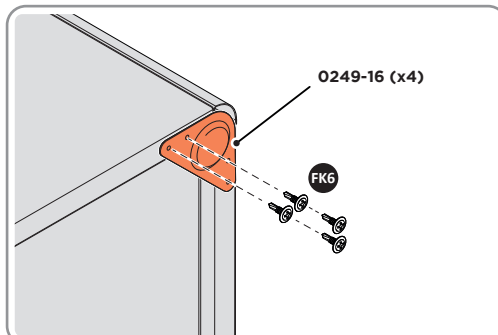
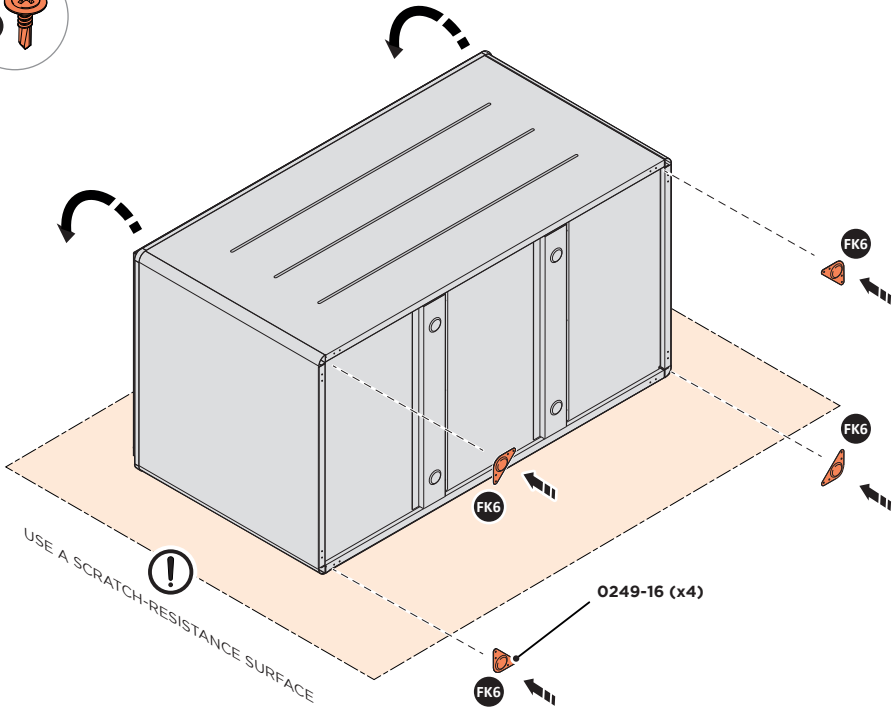

**NOTE:** CAREFULLY ROTATE THE BOX ONTO ITS SIDE; WE RECOMMEND USING A SCRATCH-RESISTANT SURFACE TO PROTECT THE PAINTWORK. LOCATE AND SECURE FEET 0249-16 AT THE LOCATIONS INDICATED ABOVE.

# Assembly Guide

## ASSEMBLY STAGE 8 ASSEMBLY LID HINGES, AS SHOWN.

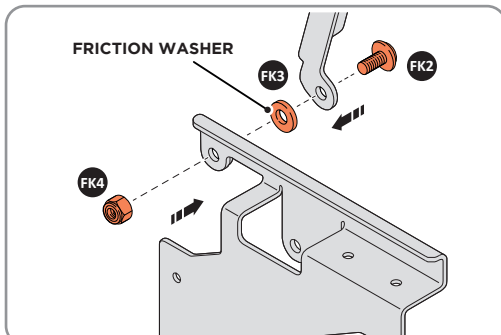
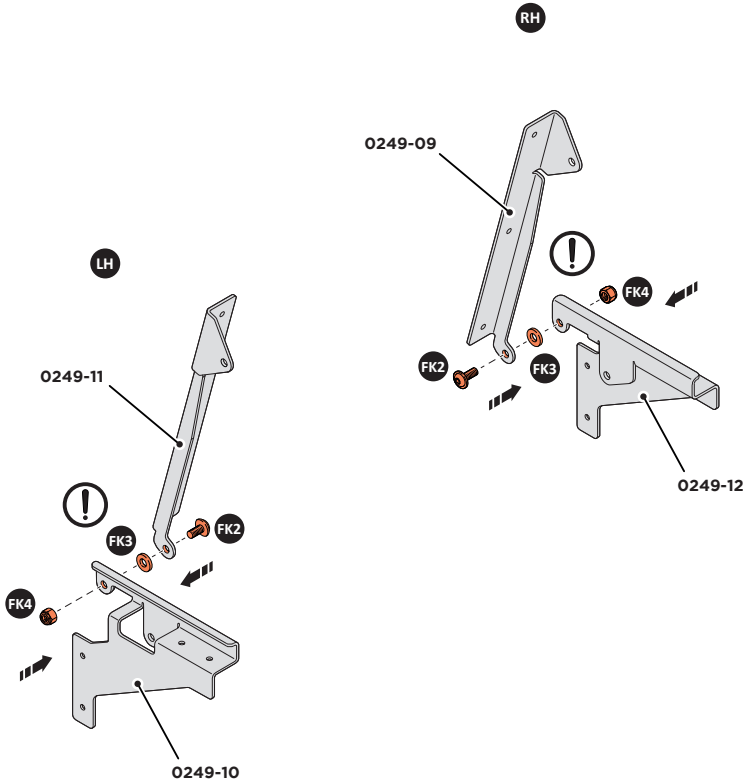

**NOTE:** ENSURE DURING ASSEMBLY THE FRICTION WASHER IS LOCATED BETWEEN THE BRACKET & HINGE.

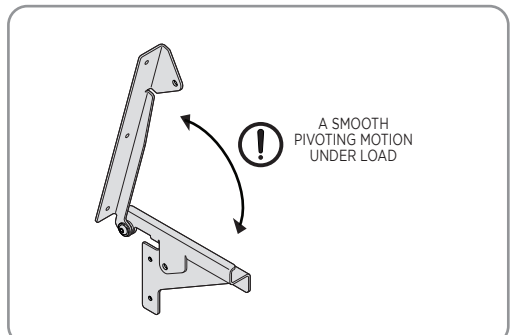

**NOTE:** AFTER TIGHTENING THE NUT & BOLT, ENSURE THE HINGE OPERATES SMOOTHLY WHILST MAINTAINING RESISTANCE ON THE FRICTION WASHER.

## ASSEMBLY STAGE 9

SECURE GAS STRUTS 0249-26 TO LID HINGES.

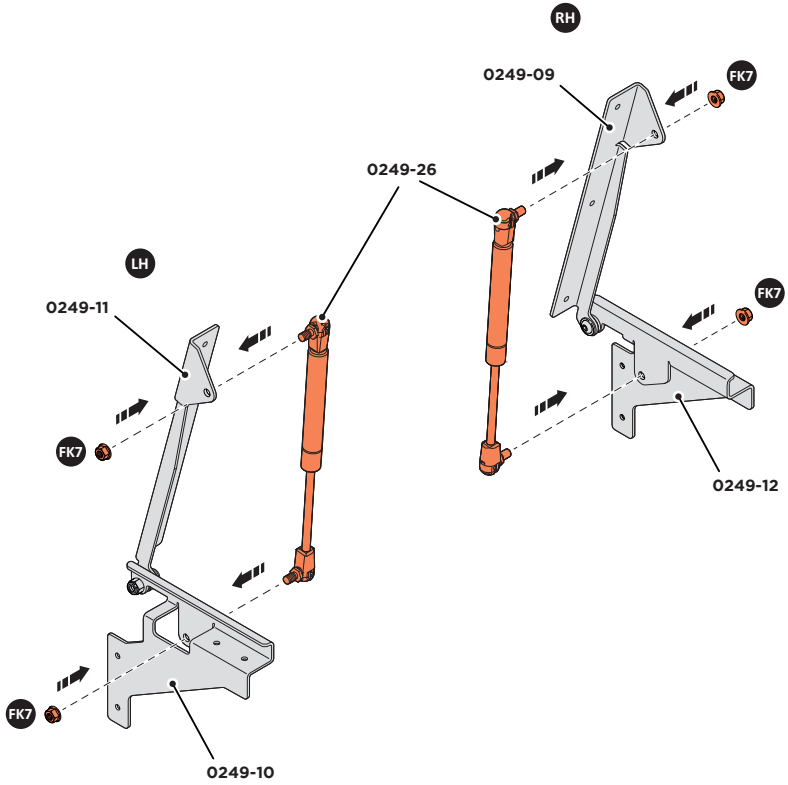

# Assembly Guide

## ASSEMBLY STAGE 10

ROTATE BOX FRAME TO IT'S UPRIGHT POSITION. SECURE GAS STRUT & LID HINGE ASSEMBLIES TO PANELS & FRAME AS SHOWN.

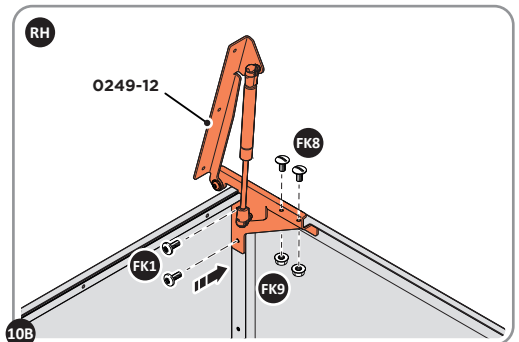
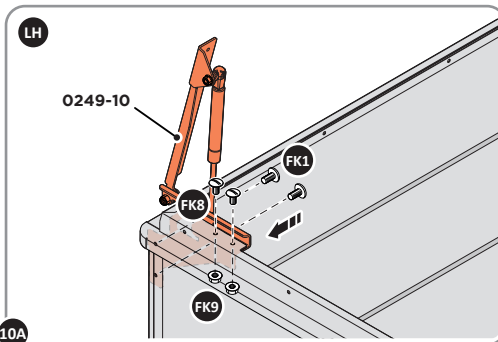
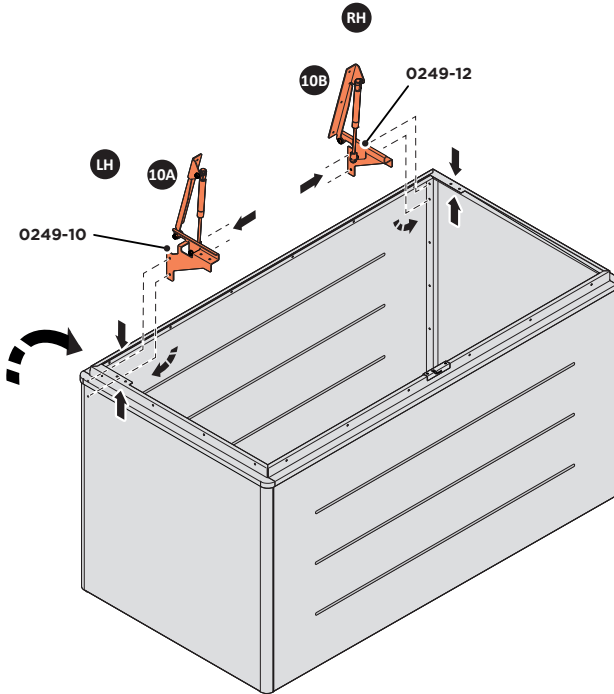

SECURE LID HINGE ASSEMBLY 0242-10, AT EACH LOCATION INDICATED.

## ASSEMBLY STAGE 11

LOCATE LID AND SECURE RUBBER FEET & SPACERS.

**NOTE:** USE A SCRATCH RESISTANCE SURFACE.

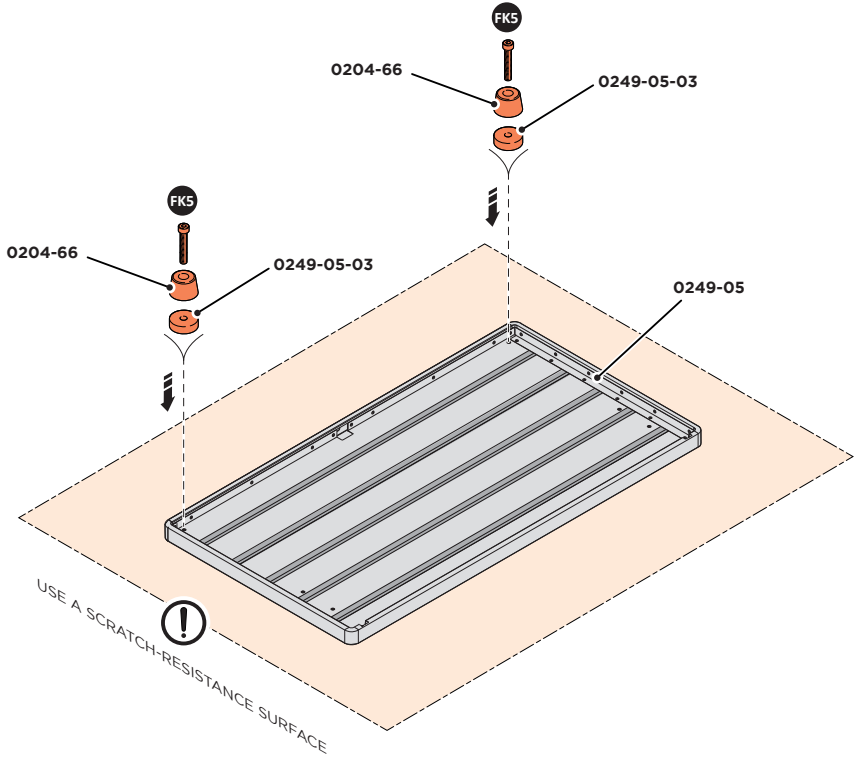



## ASSEMBLY STAGE 12

LOCATE AND SECURE CAM LOCK 0249-23, CATCH PLATE 0249-24 & BACKING PLATE 0249-25 TO LID.

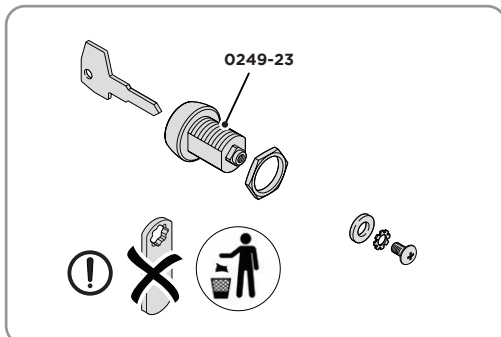
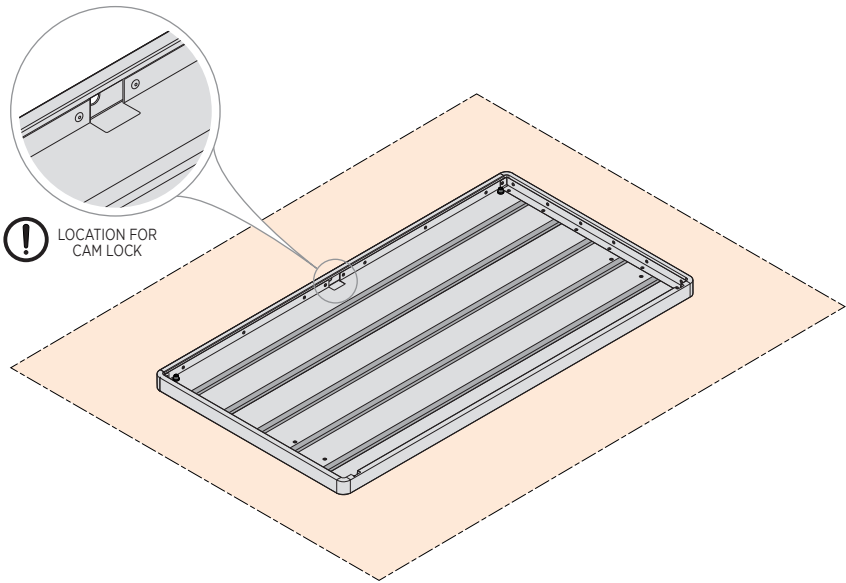
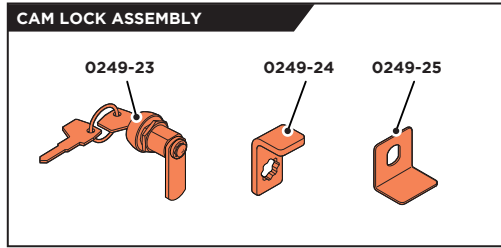

LOCATE AND DISASSEMBLE CAM LOCK ASSEMBLY 0249-23. AS SHOWN ABOVE.

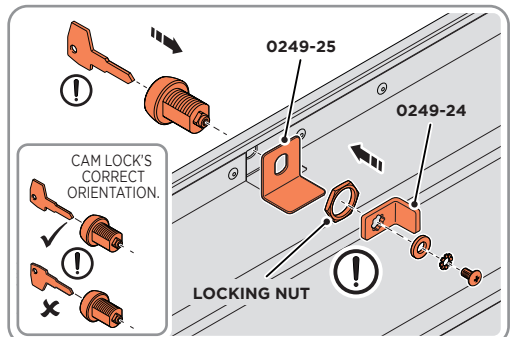

WITH THE LID IN THE UPSIDE DOWN POSITION, SECURE LOCK BACKING PLATE 0249-25 AND CAM LOCK ASSEMBLY TO LID AS SHOWN ABOVE.  
**NOTE:** M22 SOCKET WILL BE REQUIRED FOR LOCKING NUT.

# Assembly Guide

## ASSEMBLY STAGE 13

LOCATE LID 0249-05 AND SECURE TO LID HINGES 0249-10 & 0249-12.

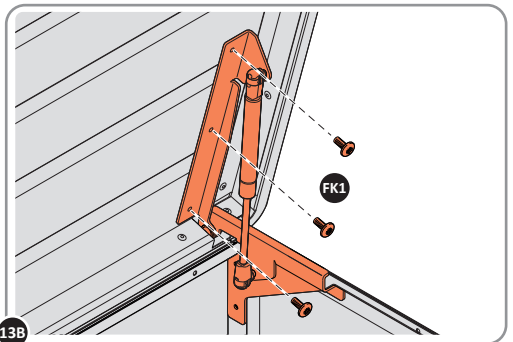
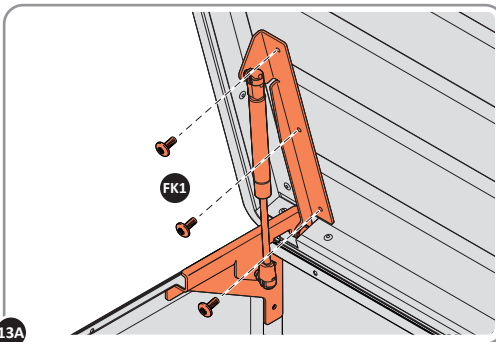
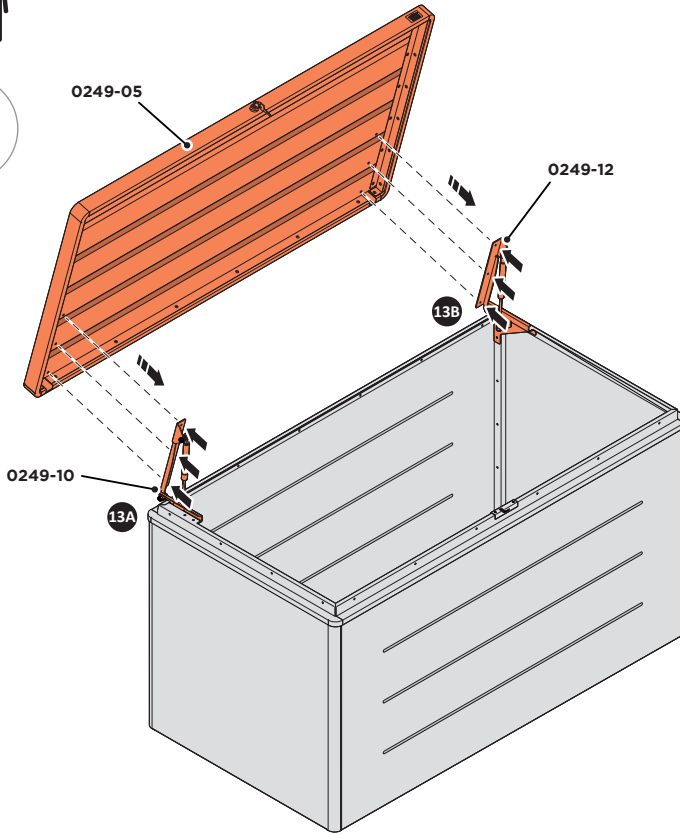

13A SECURE LID TO LID HINGES. AT LOCATIONS INDICATED ABOVE.

**ASSEMBLY STAGE 14**  
FINISHED ASSEMBLY.

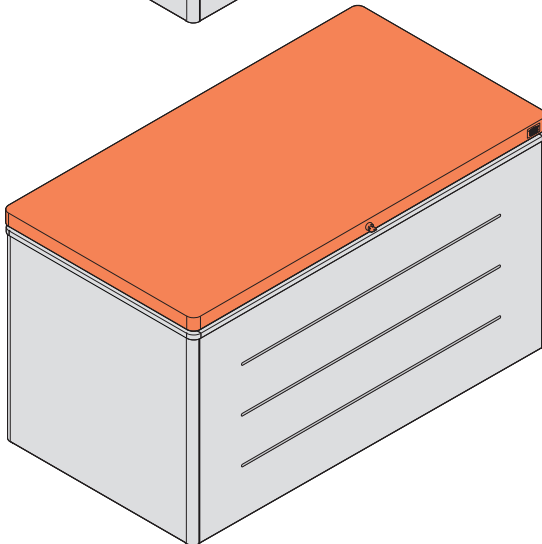
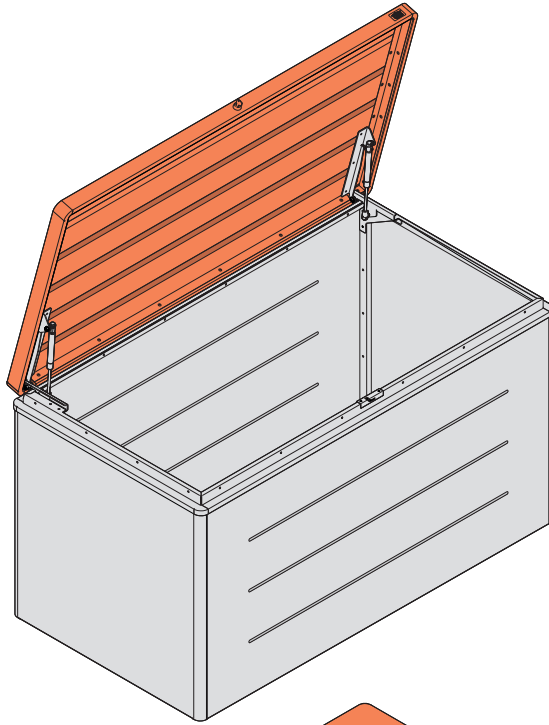

## Caring for your Stone Garden Lifestyle product

Your **Stone Garden Lifestyle** product is designed to stand the test of time, which is why we're happy to offer a **25 year warranty** on our products. With zero maintenance required, simply assemble your **Stone Garden Lifestyle** product and enjoy putting it to great use in your garden.

Periodically, you might want to give your product a clean, these simple care tips are not essential to the performance of your product:

- Remove surface dirt with plain water using a jet wash or sponge, the coating on our products will ensure dirt.
- If you've purchased a **Stone Garden Lifestyle** metal storage solution, periodically clear the roof of fallen leaves.
- If your product has guttering, remove leaves and garden debris as you would on your home. or mud simply wipes away.

**IMPORTANT: PLEASE REGISTER YOUR STONE GARDEN LIFESTYLE PRODUCT AFTER ASSEMBLY**



Doc Ref: 808-3136F2 Rev.A

## Ensure you have registered your Stone Garden Lifestyle product

Using the unique serial number found on the cover of this document, please visit  
<https://bit.ly/StoneGardenWarranty>  
to register your product and access the 25 year warranty.