

ASSEMBLY INSTRUCTIONS | INSTRUCTIONS D'ASSEMBLAGE | INSTRUCCIONES DE MONTAJE | MONTERINGSANVISNINGAR



⚠ WARNING!
CRUSH HAZARD.
KEEP HANDS AND FINGERS AWAY.



⚠ ADVERTENCIA!
PELIGRO DE APLASTAMIENTO.
MANTENGA LAS MANOS Y LOS DEDOS ALEJADOS.



⚠ AVERTISSEMENT !
RISQUE D'ÉCRASEMENT.
GARDER LES MAINS ET LES DOIGTS À L'ÉCART.



⚠ VARNING!
FARA FÖR KLÄMNING.
HÅLL HÄNDER OCH FINGRAR BORTA.

If there are any parts missing or you need further assistance, please visit: www.xrockeruk.com/pages/support
S'il manque des pièces ou si vous avez besoin d'aide, veuillez consulter le site : www.xrockeruk.com/pages/support
Si le falta alguna pieza o necesita más ayuda, visite: www.xrockeruk.com/pages/support
Om några delar saknas eller om du behöver ytterligare hjälp, vänligen besök: www.xrockeruk.com/pages/support

A		1
B		1
C		1
D		2
E		1
F	M6	1
G	M8*25	4
H	Ø8*Ø18	4
I		6
J	M8*60	6
K		1

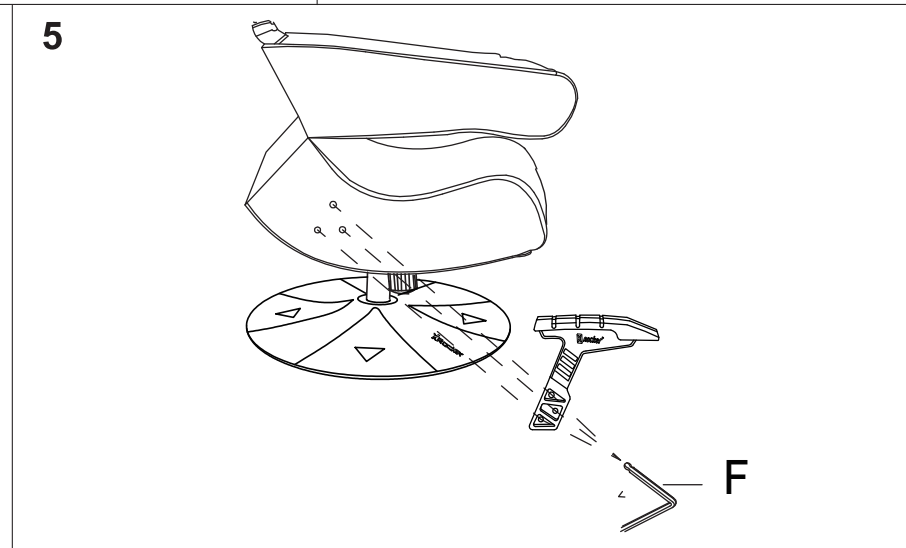
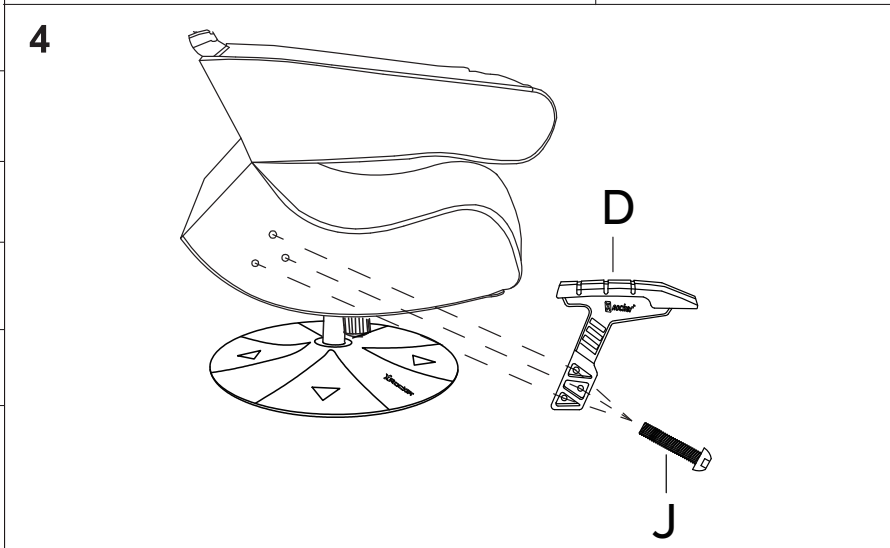
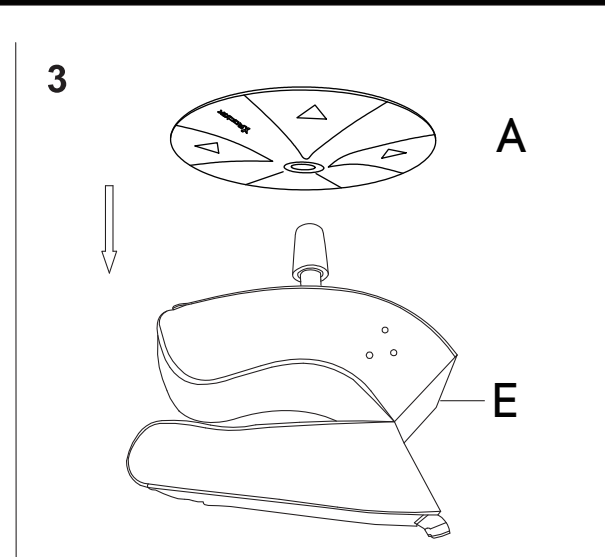
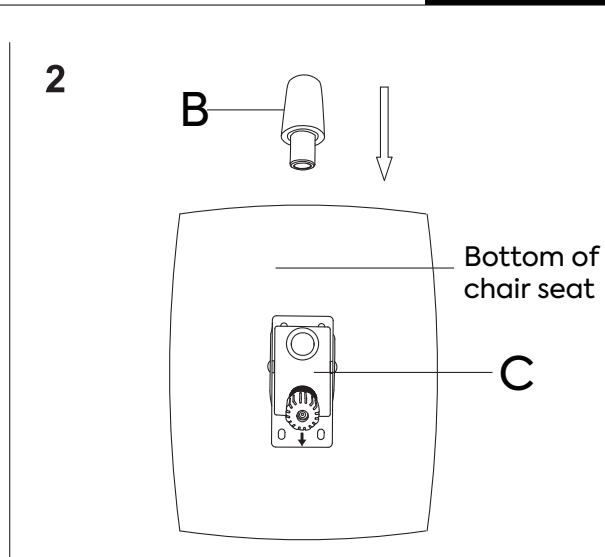
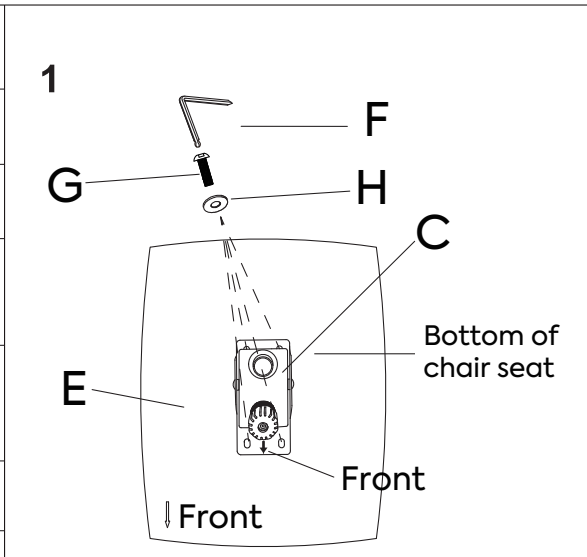

6

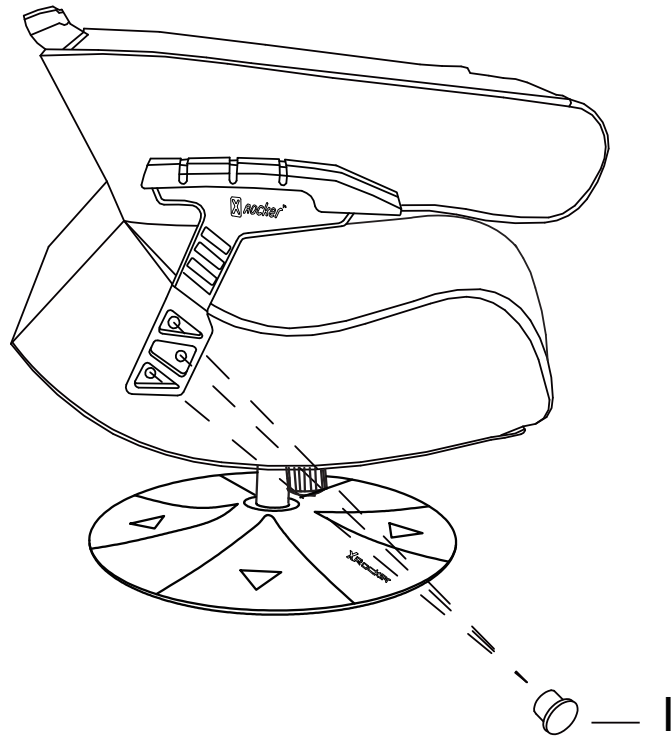

7

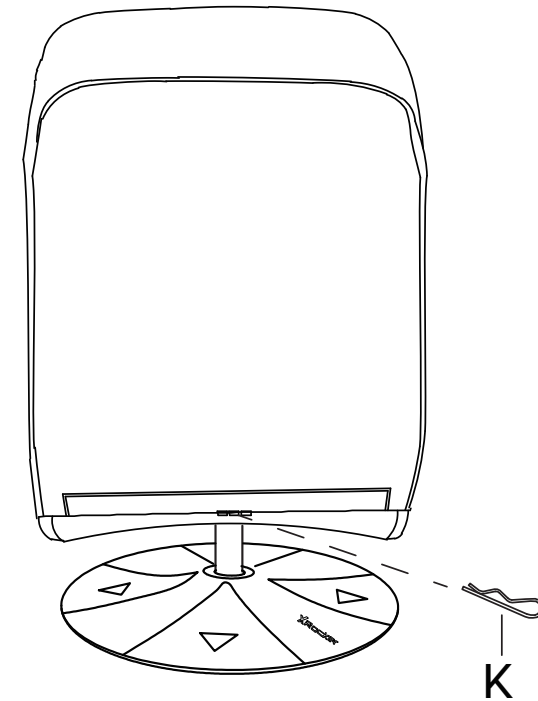

WARNING!

Chair arms are for gaming support only. To avoid damage or injury, do not sit on the arms. Do not use arms to EXIT from the chair, or to MOVE or lift the chair.

AVERTISSEMENT !

Les bras de la chaise ne servent qu'à soutenir le jeu. Pour éviter tout dommage ou blessure, ne vous asseyez pas sur les bras. Ne pas utiliser les bras pour sortir du fauteuil, ni pour le déplacer ou le soulever.

ADVERTENCIA!

Los brazos de la silla son sólo para apoyar el juego. Para evitar daños o lesiones, no se sienten en los brazos. No utilice los brazos para SALIR de la silla, ni para MOVER o levantar la silla.

VARNING!

Stolens armar är endast avsedda som stöd vid spel. Sitt inte på armarna för att undvika skador eller personskador. Använd inte armarna för att gå ur stolen, eller för att flytta eller lyfta stolen.

