



Manufactured by:
Backyard Discovery
3305 Airport Drive, Pittsburg, KS 66762
800-856-4445

Basepoint Business Centre: Rivermead Drive, Westlea, Swindon SN5 7EX Phone: 0800-118-2476 J.P. Coenstraat 7, The Bridge, The Hague, 2595 WP, Netherlands
Phone: 08005678990

14x12 Barrington Gazebo

MODEL # : 2406247

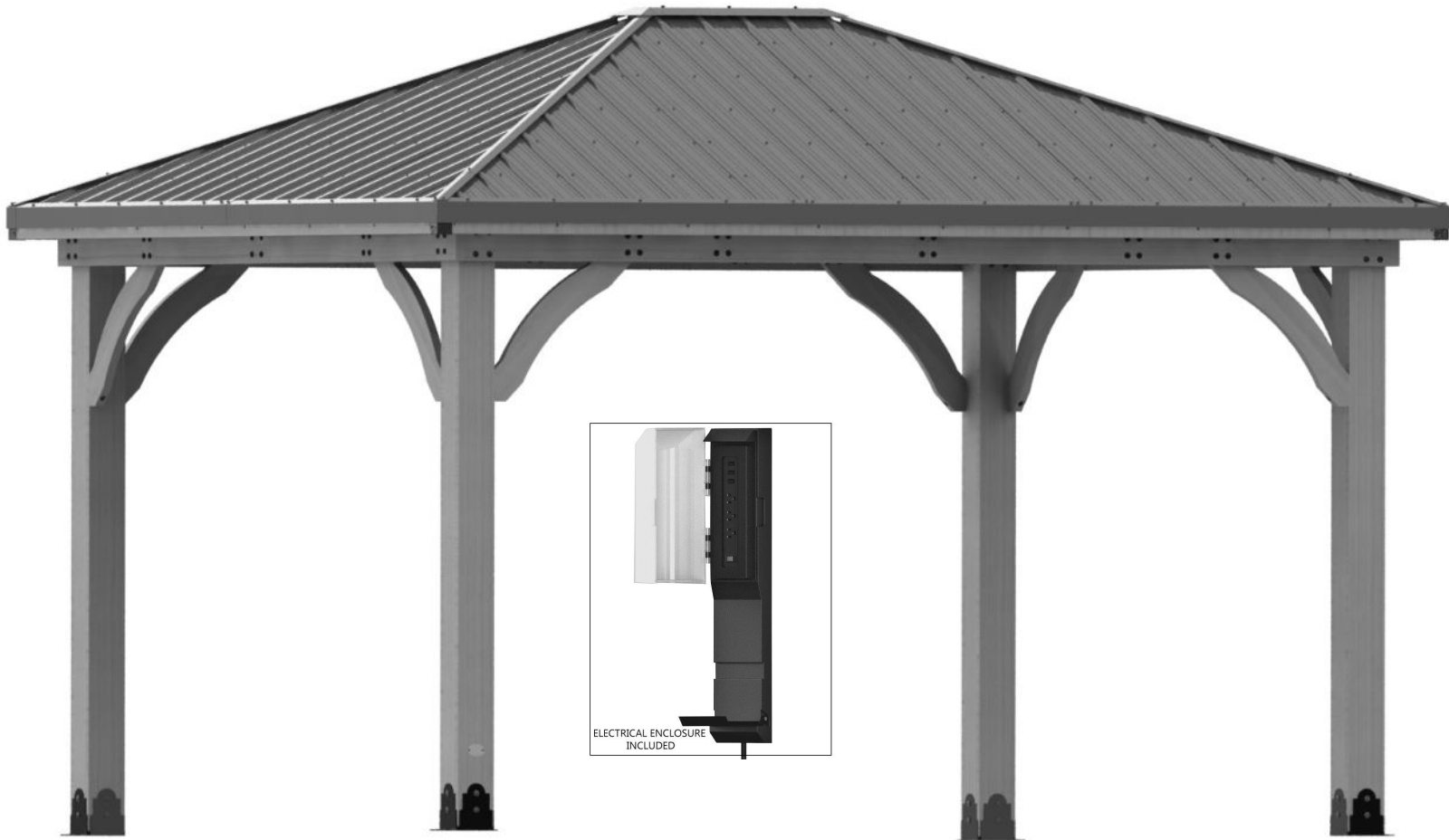

Please visit www.backyarddiscovery.com
For the most up to date assembly manual, to register your product, or to order replacement parts *Para obtener instrucciones en español, visite*
www.backyarddiscovery.com



EASY STEP-BY-STEP
3D INTERACTIVE INSTRUCTIONS
DOWNLOAD THE FREE APP



OWNER'S MANUAL - BASIC SETUP DIMENSIONS & ASSEMBLY NOTES

It is critically important that you start with square and level footings, concrete pad or deck to attach your structure

- Pay close attention to the items needed for each step. Make sure you are using the correct hardware for each step. Using incorrect hardware may result in improper assembly
- Remember to double check for underground utilities and overhead electrical lines

Post mounts are provided with your structure which allows you to permanently install your structure to a pre-existing or new wood or concrete surface. See Anchor Instructions for further details and recommendations.

- The hardware to attach the post mounts to the structure is included.
- The hardware to mount the structure permanently to a concrete surface is included.
- The hardware to mount the structure permanently to a wood deck is NOT included and will need to be purchased separately. You must ensure there is ample structural support under the deck before permanently attaching.

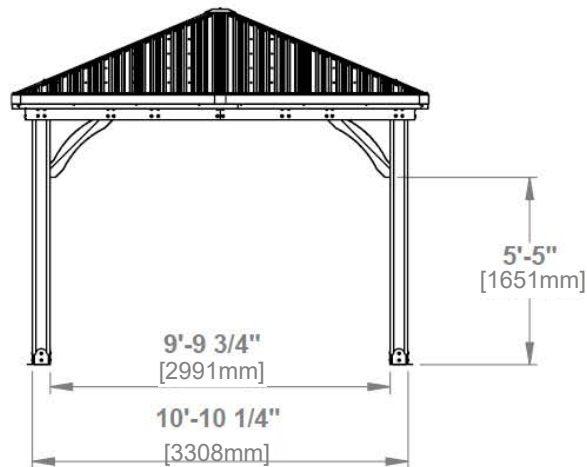
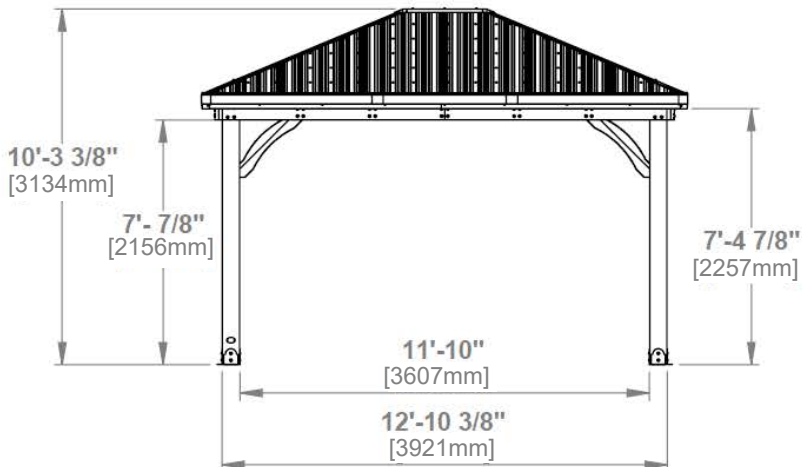
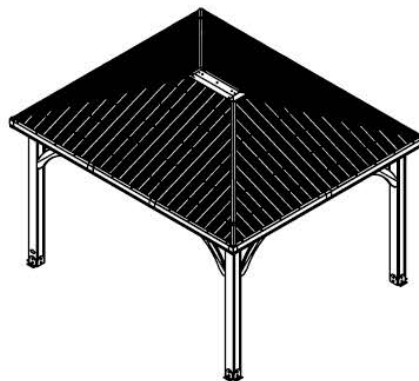
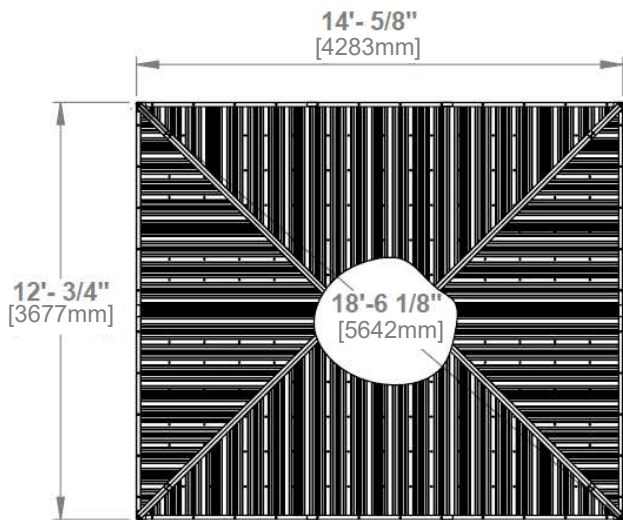

OWNER'S MANUAL - ANCHORING LAYOUT

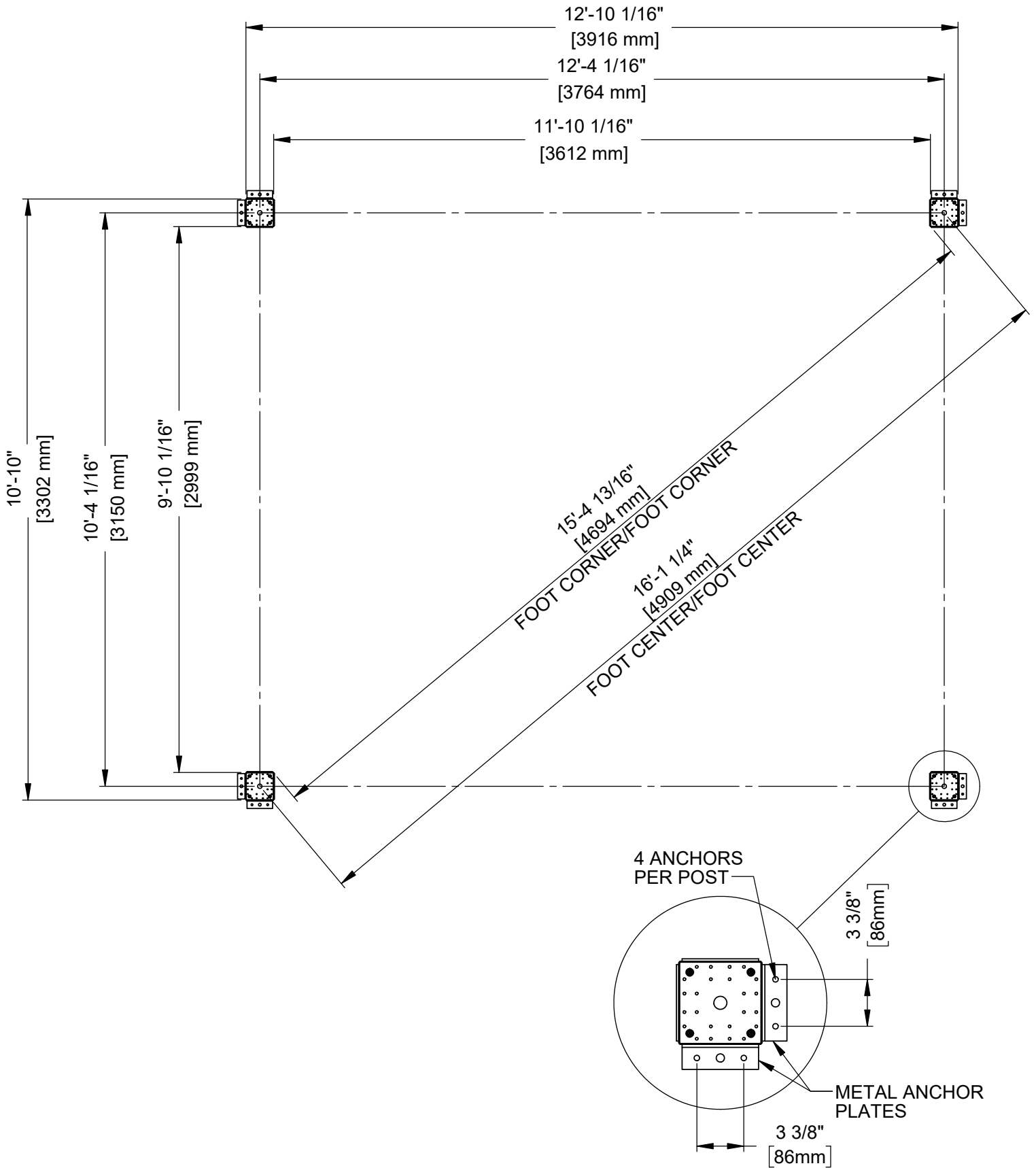

OWNER'S MANUAL - PARTS IDENTIFICATION

Wood Components (Not to Scale)



H01 | ROOF SUPPORT - W4L15194

(4) | 1"x3 3/8"x54 1/8" (24x86x1374)



H02 | ROOF JOIST - W4L15195

(2) | 1"x3 3/8"x61 1/4" (24x86x1556)



H03 | ROOF JOIST - W4L15197

(2) | 1"x3 3/8"x22 7/8" (24x86x580)



H04 | ROOF SUPPORT - W4L15201

(4) | 1"x3 3/8"x38 13/16" (24x86x986)



H05 | ROOF JOIST - W4L15202

(2) | 1"x3 3/8"x44 9/16" (24x86x1132)

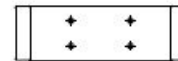

H06 | ROOF JOIST - W4L15203

(2) | 1"x3 3/8"x10 11/16" (24x86x272)



H07 | ROOF JOIST - W4L15205

(2) | 1"x3 3/8"x53 3/16" (24x86x1351)



H08 | ROOF JOIST - W4L15206

(2) | 1"x3 3/8"x53 3/16" (24x86x1351)



H09 | ROOF JOIST - W4L15213

(2) | 1"x3 3/8"x61 1/4" (24x86x1556)



H10 | ROOF JOIST - W4L15214

(2) | 1"x3 3/8"x44 9/16" (24x86x1132)



H11 | ROOF JOIST - W4L15216

(2) | 1"x3 3/8"x44 1/2" (24x86x1130)



H12 | ROOF JOIST - W4L15220

(2) | 1"x3 3/8"x44 1/2" (24x86x1130)

OWNER'S MANUAL - PARTS IDENTIFICATION

Wood Components (Not to Scale)

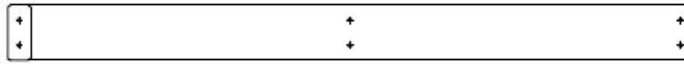

H13 | PURLIN - W4L15222
(2) | 1"x3 3/8"x43 11/16" (24x86x1110)



H14 | PURLIN - W4L15223
(4) | 1"x3 3/8"x54 9/16" (24x86x1385)



H15 | PURLIN - W4L15224
(4) | 1"x3 3/8"x63 1/8" (24x86x1603)

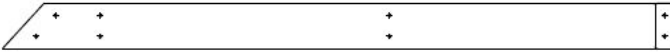

H16 | PURLIN - W4L15225
(4) | 1"x3 3/8"x51" (24x86x1295)

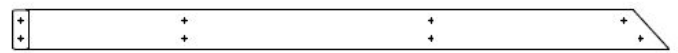

H19 | PURLIN - W4L15228
(2) | 1"x3 3/8"x58 5/16" (24x86x1481)

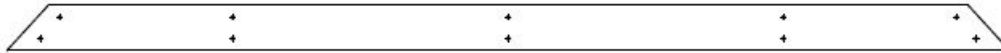

H17 | PURLIN - W4L15226
(2) | 1"x1 3/8"x75 3/8" (24x34x1915)



H20 | PURLIN - W4L15229
(2) | 1"x3 3/8"x43 7/8" (24x86x1114)

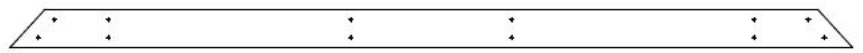

H21 | PURLIN - W4L15230
(2) | 1"x3 3/8"x75 11/16" (24x86x1922)

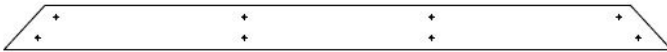

H22 | PURLIN - W4L15231
(2) | 1"x3 3/8"x51 7/16" (24x86x1307)



H24 | PURLIN W4L15232
(2) | 1"x3 3/8"x27 1/4" (24x86x692)



H25 | PURLIN - W4L15235
(2) | 1"x3 3/8"x51 3/16" (24x86x1299)



H27 | PURLIN - W4L15237
(2) | 1"x3 3/8"x56" (24x86x1422)



H29 | ROOF SUPPORT - W4L15160
(1) | 1"x3 3/8"x24" (24x86x610)

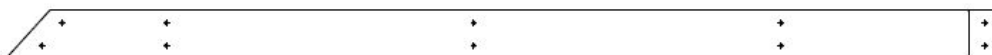

H28 | PURLIN - W4L15238
(2) | 1"x3 3/8"x70 1/2" (24x86x1791)

OWNER'S MANUAL - PARTS IDENTIFICATION

Wood Components (Not to Scale)



E01 | RAFTER- W4L15196
(2) | 1 3/8"x3 3/8"x76 3/4" (36x86x1949)

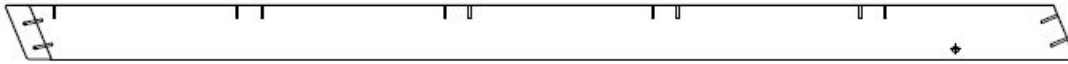

E02 | RAFTER- W4L15198
(2) | 1 3/8"x3 3/8"x67 5/8" (36x86x1717)



E03 | RAFTER- W4L15199
(2) | 1 3/8"x3 3/8"x44 1/16" (36x86x1119)

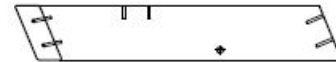

E04 | RAFTER- W4L15200
(2) | 1 3/8"x3 3/8"x20 1/2" (36x86x520)



E05 | RAFTER - W4L15207
(2) | 1 3/8"x3 3/8"x69" (36x86x1752)



E06 | RAFTER - W4L15208
(2) | 1 3/8"x3 3/8"x45 7/16" (36x86x1155)



E07 | RAFTER- W4L15209
(2) | 1 3/8"x3 3/8"x21 15/16" (36x86x557)



E08 | RAFTER - W4L15210
(2) | 1 3/8"x3 3/8"x67 5/8" (36x86x1717)



E09 | RAFTER - W4L15211
(2) | 1 3/8"x3 3/8"x44 1/16" (36x86x1119)

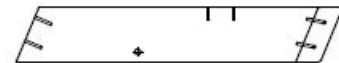

E10 | RAFTER- W4L15212
(2) | 1 3/8"x3 3/8"x20 1/2" (36x86x520)



E11 | RAFTER- W4L15217
(2) | 1 3/8"x3 3/8"x69" (36x86x1752)



E12 | RAFTER W4L15218
(2) | 1 3/8"x3 3/8"x45 7/16" (36x86x1155)



E13 | RAFTER- W4L15219
(2) | 1 3/8"x3 3/8"x21 15/16" (36x86x557)

OWNER'S MANUAL - PARTS IDENTIFICATION

Wood Components (Not to Scale)



C01 | CORBEL- W2A03198
(7) | 1 7/16"x6 7/16"x35 1/8" (36x163x893)



D01 | BEAM- W4L15192
(4) | 1 3/8"x5 1/4"x45 3/16" (36x134x1148)



C02 | CORBEL W/TAG- W2A03199
(1) | 1 7/16"x6 7/16"x35 1/8" (36x163x893)



D02 | BEAM - W4L15191
(4) | 1 3/8"x5 1/4"x52 1/16" (36x134x1322)



D03 | BEAM - W4L15193
(2) | 1 3/8"x5 1/4"x49 15/16" (36x134x1268)



D04 | BEAM - W4L15234
(4) | 1 3/8"x5 1/4"x77" (36x134x1956)



D05 | BEAM - W4L15240
(2) | 1 3/8"x5 1/4"x77" (36x134x1150)

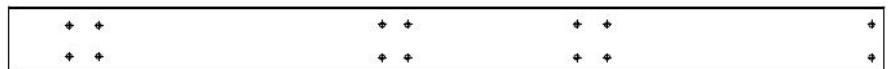

D06 | BEAM - W4L15241
(4) | 1 3/8"x5 1/4"x67 13/16" (36x134x1723)



Q01 | ROOF JOIST- W4L15204
(2) | 1"x4 7/16"x65 15/16" (24x112x1675)

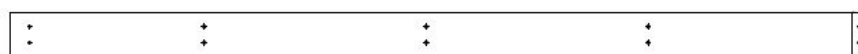

Q02 | ROOF JOIST- W4L15215
(4) | 1"x4 7/16"x84 1/4" (24x112x2140)



Q03 | ROOF JOIST- W4L15221
(2) | 1"x4 7/16"x80 1/2" (24x112x2044)

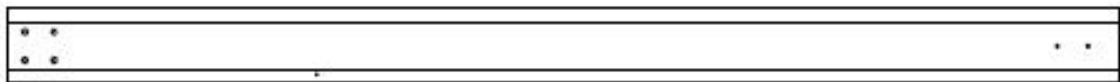

P01 | POST - W2A03202
(2) | 6"x6"x89 1/2" (152x152x2274)

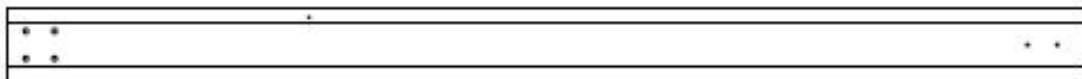

P02 | POST - W2A03203
(2) | 6"x6"x89 1/2" (152x152x2274)



T01 | PURLIN - W4L15227
(2) | 1"x1 5/16"x27 1/2" (24x34x698)



T02 | PURLIN- W4L15239
(2) | 1"x1 5/16"x12 3/4" (24x34x324)

OWNER'S MANUAL - PARTS IDENTIFICATION

Hardware Components

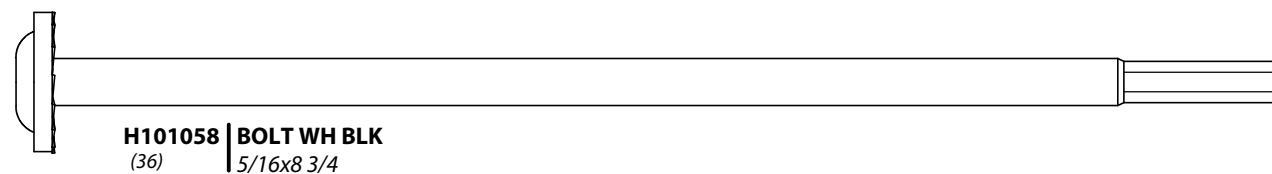
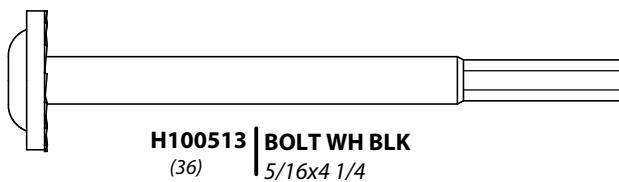
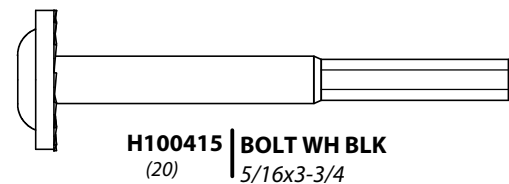
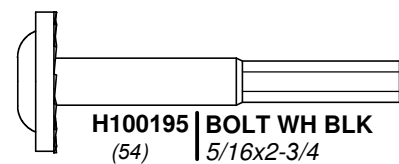
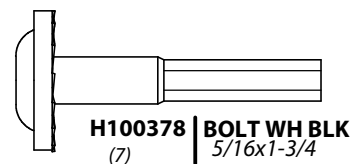
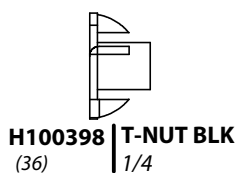
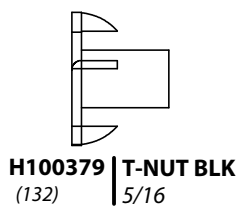
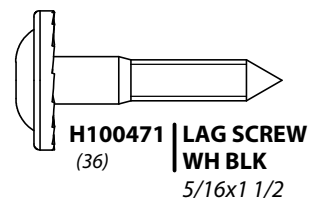
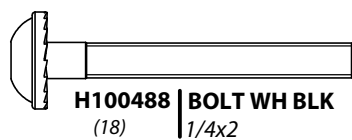
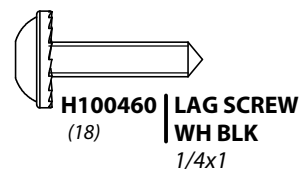
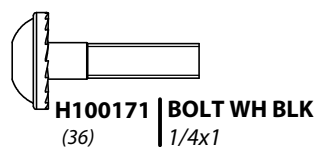

OWNER'S MANUAL - PARTS IDENTIFICATION

Hardware Components

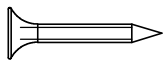

H100385 | SCREW PFH BLK
(202) | 8x1

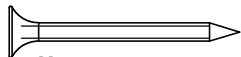

H100200 | SCREW PFH BLK
(20) | 8x1 1/2

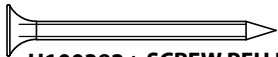

H100382 | SCREW PFH BLK
(22) | 8x1 3/4



H100391 | SCREW PFH BLK
(278) | 8x2

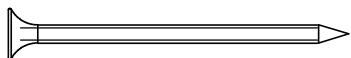

H100483 | SCREW PFH BLK
(54) | 8x2 1/4

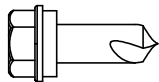

H100759 | SCREW TAPPING
(63) | 1/4x3/4

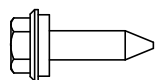

H100833 | SCREW WOODGRIP
(309) | 10x3/4

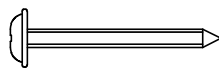

H100536 | SCREW PWH BLK
(40) | 8x1 1/4



H100392 | SCREW PWH BLK
(18) | 8x3/4

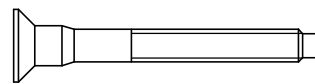

H101030 | SCREW CONFIRMAT BLK
(116) | 7x2

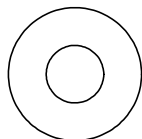

H100770 | WASHER FLAT BLK 5/16
(20)



H101034 | WEATHER PROOF WASHER
(3)



H100479 | NUT LOCK BLK 5/16
(20)

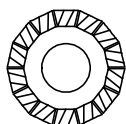

H100198 | WASHER LOCK EXT BLK 8x19
(152)

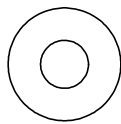

H100630 | WASHER FLAT BLK 8x19
(36)

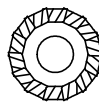

H100405 | WASHER LOCK EXT BLK 6x15
(9)

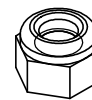

H100653 | NUT LOCK BLK 1/4
(18)

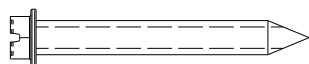

H100120 | SCREW CONCRETE ANCHOR
(18) | 1/4x2

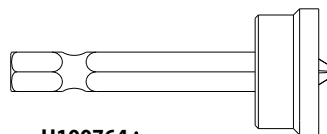

H100764 | SCREW SETTER
(1)

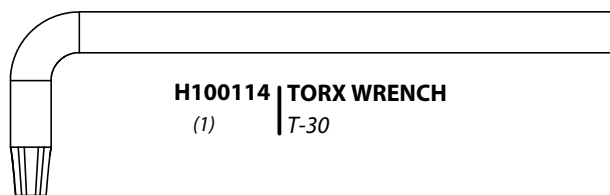

H100114 | TORX WRENCH
(1) | T-30

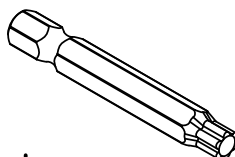

H100147 | T-30 TORX BIT
(1)

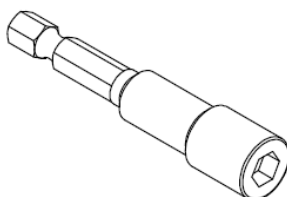

H101106 | SOCKET DRIVER
(1)

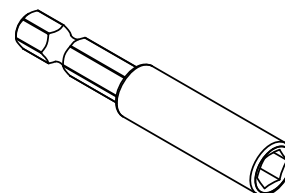

H101100 | BIT ADAPTOR
(1)

OWNER'S MANUAL - PARTS IDENTIFICATION

Accessory Components (Not to Scale)

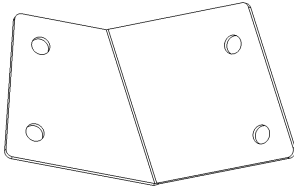

A4M01191 | PANEL BRACKET
(2)

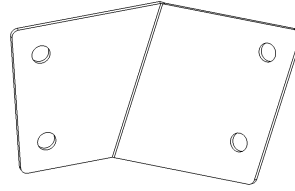

A4M01193 | PANEL BRACKET
(2)

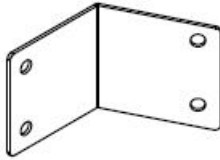

A4M01238 | PANEL BRACKET
(2)

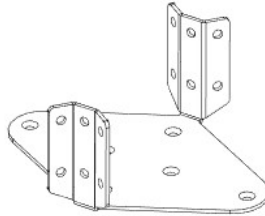

A4M02501 | SOPORTE DE VENTILADOR
(1)

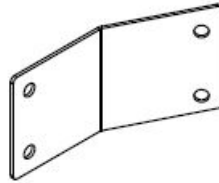

A4M01239 | PANEL BRACKET
(2)

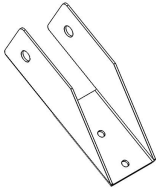

A4M01228 | RAFTER CLIP
(16)

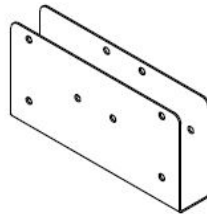

A4M01237 | ROOF SUPPORT SPLICE CLIP
(12)

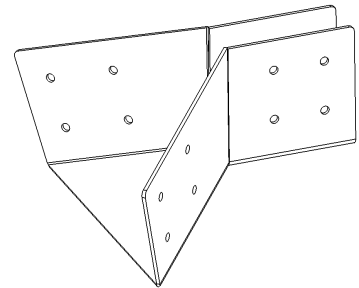

A4M01184 | PANEL SUPPORT BRACKET
(2)

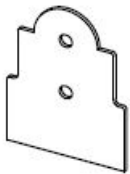

A4M01794 | STEEL POST PLATE
(8)



A4M01793 | STEEL POST ANCHOR PLATE
(8)

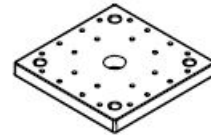

A6P00308 | 6x6 POST FOOT
(4)

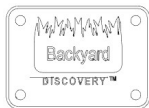

A4M02158 | BYD ID TAG (SMALL) WITHOUT AGES
(1)

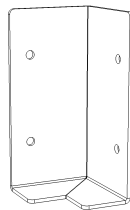

A4M01185 | CORNER BRACKET
(4)

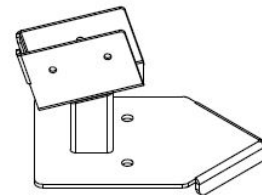

A4M01234 | POST CLIP
(4)

OWNER'S MANUAL - PARTS IDENTIFICATION

Accessory Components (Not to Scale)

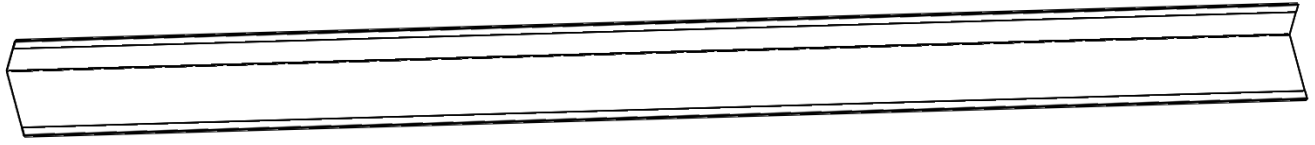

A4M02885 | EDGE TRIM LONG
(4)

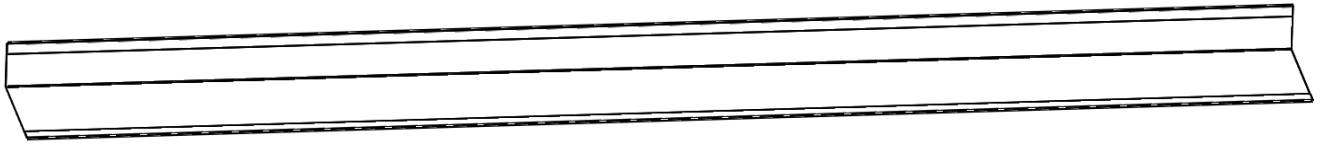

A4M02869 | EDGE TRIM SHORT
(2)

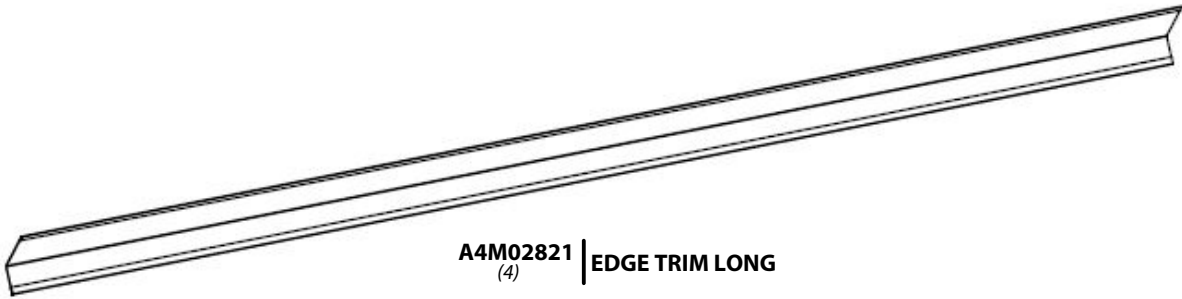

A4M02821 | EDGE TRIM LONG
(4)

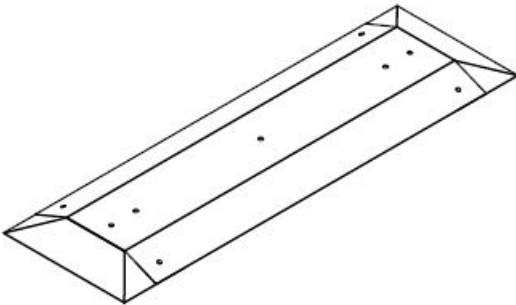

A4M02886 | RIDGE PEAK CAP
(1)

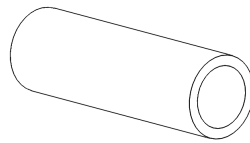

A4M01205 | METAL SPACER
(3)

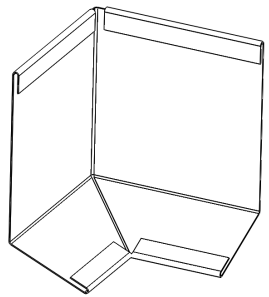

A4M02825 | EDGE TRIM CORNER SPLICE
(4)

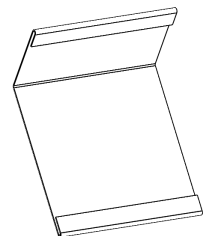

A4M02822 | EDGE TRIM SPLICE
(6)

OWNER'S MANUAL - PARTS IDENTIFICATION

Accessory Components (Not to Scale)

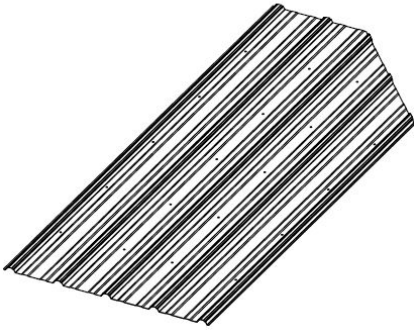

A4M02879-1 | 29 GA STEEL SHEETING
(2)



A4M02879-2 | 29 GA STEEL SHEETING
(2)

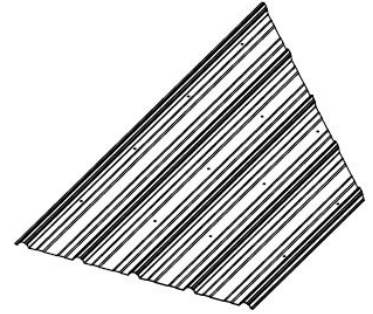

A4M02880-1 | 29 GA STEEL SHEETING
(2)

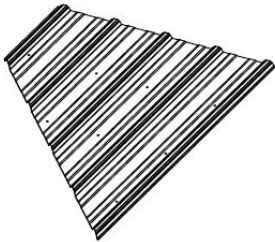

A4M02880-2 | 29 GA STEEL SHEETING
(2)

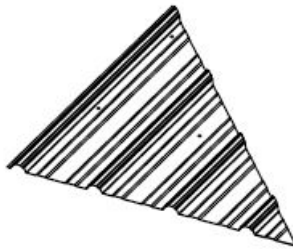

A4M02881-1 | 29 GA STEEL SHEETING
(2)

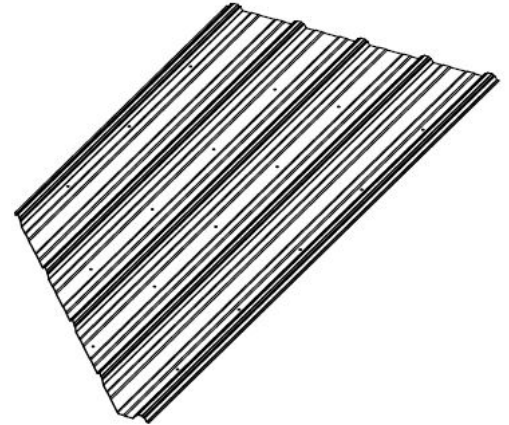

A4M02881-2 | 29 GA STEEL SHEETING
(2)

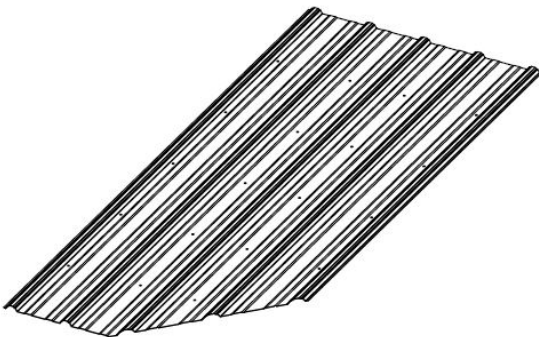

A4M02882-1 | 29 GA STEEL SHEETING
(2)



A4M02882-2 | 29 GA STEEL SHEETING
(2)

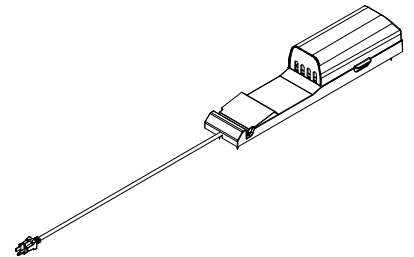

9240063 | ELECTRICAL ENCLOSURE
(x1)

OWNER'S MANUAL - PARTS IDENTIFICATION

Accessory Components (Not to Scale)

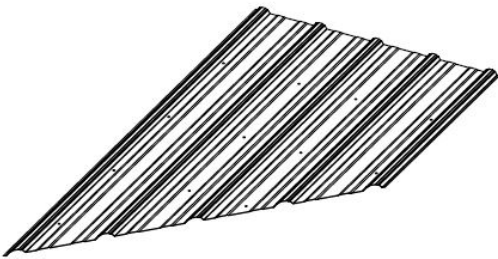

A4M02883-1 | 29 GA STEEL SHEETING
(2)

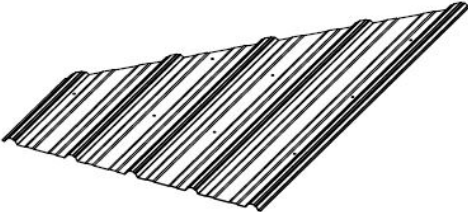

A4M02883-2 | 29 GA STEEL SHEETING
(2)

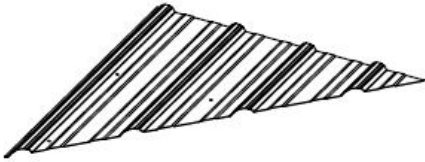

A4M02884-1 | 29 GA STEEL SHEETING
(2)

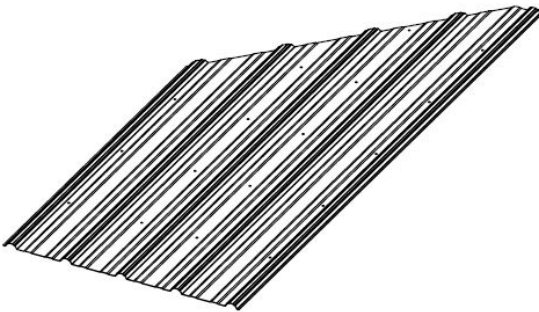

A4M02884-2 | 29 GA STEEL SHEETING
(2)

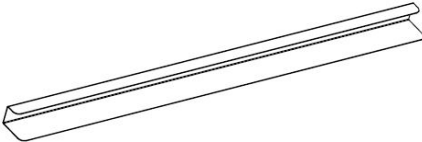

A4M02850 | RIDGE CAP CHANNEL SHORT
(8)

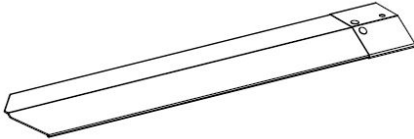

A4M02867 | RIDGE CAP SPLICE ASSEMBLY
(4)



A4M02847 | RIDGE CAP CHANNEL LONG
(8)



A4M02826 | CORNER RIDGE CAP LONG
(4)

PRE-ASSEMBLY STEP 1 - SORTING PARTS

It is critical for ease of assembly that you take the time to sort and organize the wood and hardware.

WOOD PARTS:

- Organize wood parts by the three-digit, alpha-numeric number stamped on each board (ex. P01).
- If there are multiple boards with the same stamped number, stack those pieces together.
- Stamps can be found on the flat surface of the boards or on the end of the boards.
- Allow yourself plenty of room - the wood pieces can take up a significant amount of space.

NOTE: CARTONS ARE NOT ORGANIZED BY BOARD NUMBER.



HARDWARE PARTS:

- We recommend that you have a separate table to organize the hardware.
- Hardware bags are printed with a seven-digit, alpha-numeric part number.
- You can organize your hardware by part number or group by hardware type (i.e. bolts, nuts, etc.).
- During assembly you only need to reference the last four digits of the number.

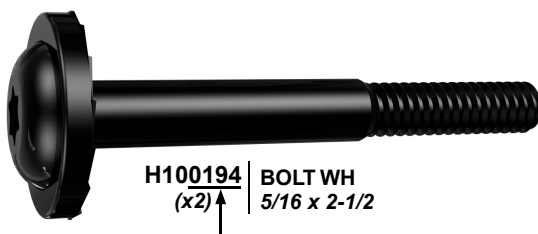

H100194 | BOLT WH
(x2) ↑ 5/16 x 2-1/2

PRE-ASSEMBLY STEP 2 - TOOLS REQUIRED



Cordless Drill or
Electric Drill



Drill Attachments:
Phillips Head



1/8", 3/16", 3/8" &
7/16" Drill Bits



Phillips Screw Driver

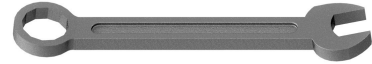

Open End
Wrenches 1/2" &
7/16"



3/8" Drive Ratchet, 1/2" &
7/16" STD Sockets, 1/2" &
7/16" Deep Sockets



Tape Measure



Claw Hammer



3/8 & 5/16" Nut Drivers

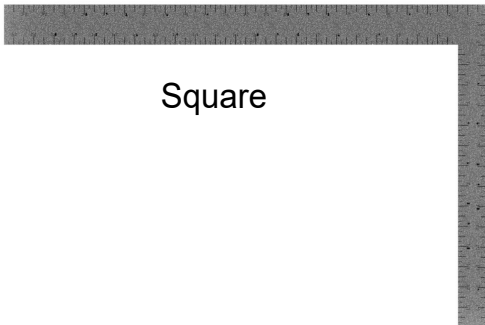

Square



Level 24"

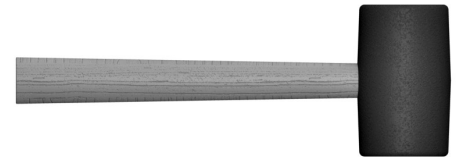

Rubber Mallet -
Optional

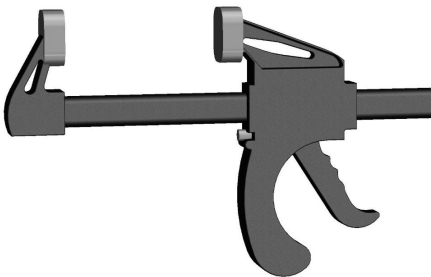

A6P00460 | QUICK RELEASE
(2) BAR CLAMP

PRE-ASSEMBLY STEP 3 - CHOOSE YOUR ASSEMBLY METHOD

There are several types of assembly instructions available to you.

1. Printed Assembly Manual included with your set
2. BILT APP - 3D interactive instructions
3. Combination of the Printed Manual and BILT APP (Note: Step numbers can differ between the two methods)



The graphic is a rectangular advertisement for the BILT app. At the top left is the BILT logo, which consists of a stylized hexagonal icon with a dot in the center, followed by the word "BILT." in a bold, sans-serif font. To the right of the logo is a large QR code. Below the logo and QR code, the text "Scan for easy 3D instructions" is written in a large, bold, black font. Underneath this, in a smaller font, it says "Download the BILT app before you begin". To the right of this text are two buttons: "Download on the App Store" with the Apple logo and "GET IT ON Google Play" with the Google Play logo. At the bottom of the graphic is a smartphone screen displaying a 3D assembly instruction. The screen shows a grey 3D model of a structure with a horizontal beam and a triangular support. A red arrow points to a specific part of the structure. The screen also has a "Partners Needed" label at the top left, a close button (X) at the top right, and navigation arrows at the bottom.

STEP 1 - 12FT POST ASSEMBLY



P01 | POST - W2A03202
(1) | 6"x6"x89 1/2" (152x152x2274)

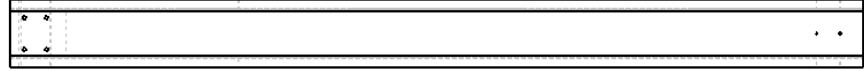

P02 | POST - W2A03203
(1) | 6"x6"x89 1/2" (152x152x2274)

QTY.	PART NUMBER	DESCRIPTION
8	H100200	SCREW PFH 8x1 1/2" BLK

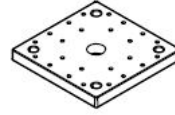

A6P00308 | 6x6 POST FOOT
(2)

- TIP:**
- FOR EASE OF ASSEMBLY, SAW HORSES ARE RECOMMENDED FOR STEPS 1 THROUGH 3

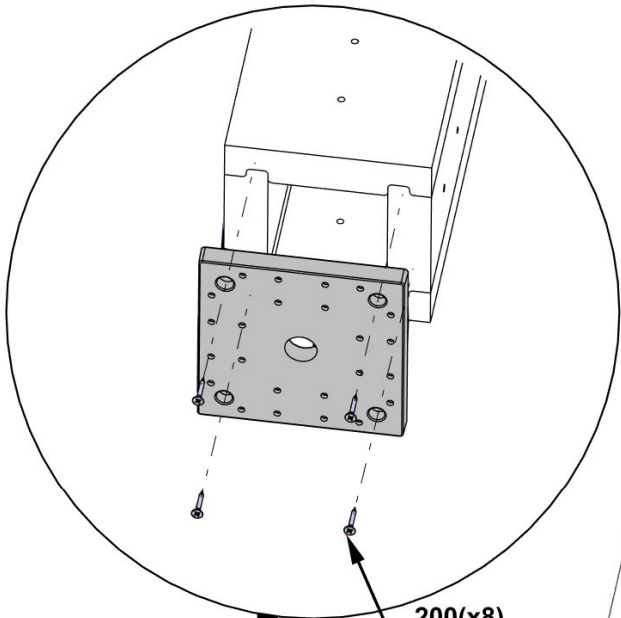

200(x8)
SCREW 1 1/2"

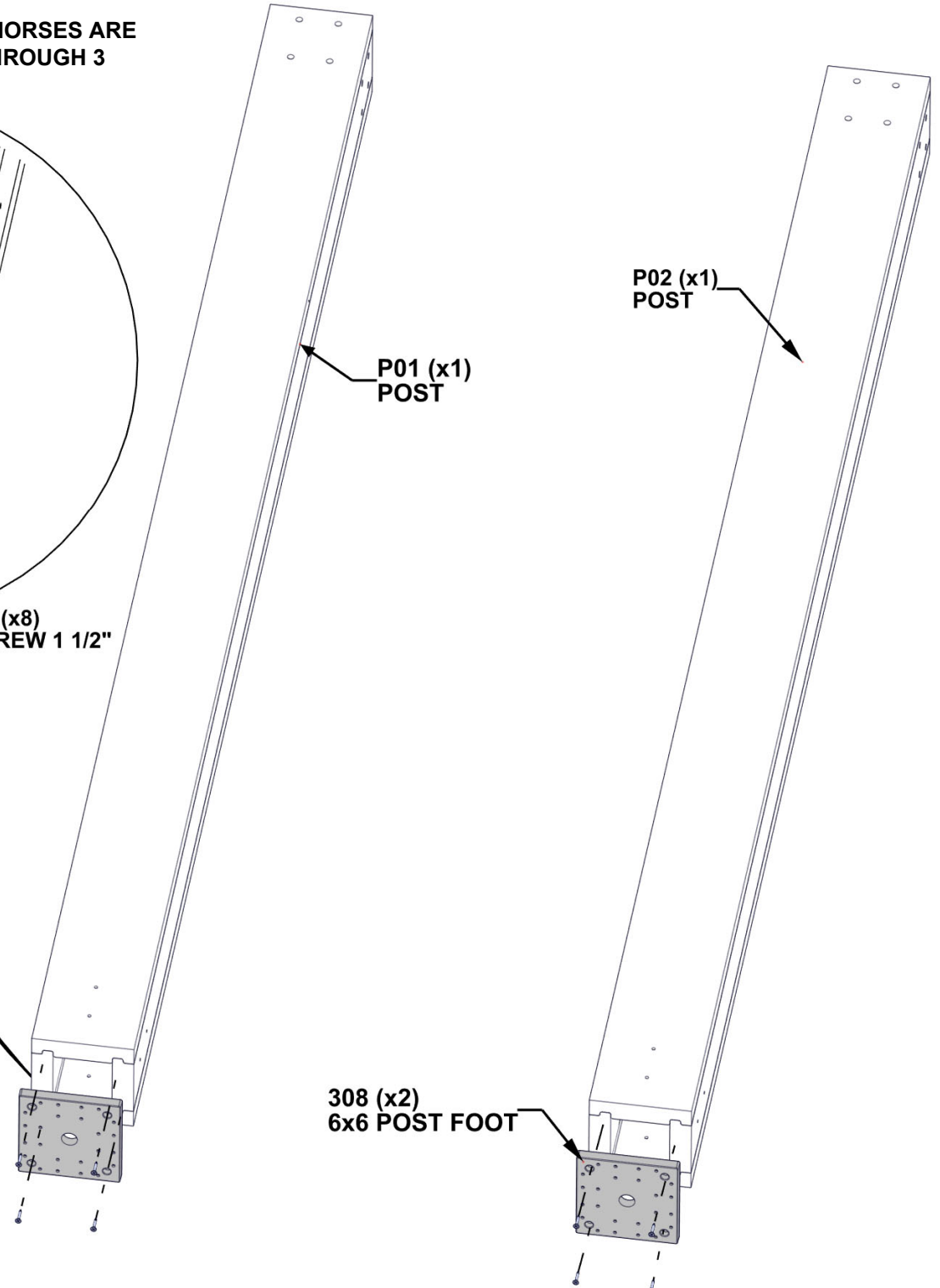

308 (x2)
6x6 POST FOOT

ALIGN POST FOOT AND DRILL 1/8" PILOT HOLES FOR THE ATTACHMENT OF HARDWARE

STEP 2 - 12FT BEAM ASSEMBLY

QTY	PART NUMBER	DESCRIPTION
8	H100198	WASHER LOCK EXT 8X19 BLK
8	H100195	BOLT WH 5/16X2 3/4 BLK
8	H100379	T-NUT 5/16" BLK



D05 | BEAM - W4L15240
 (1) | 1 3/8"x5 1/4"x77" (36x134x1150)

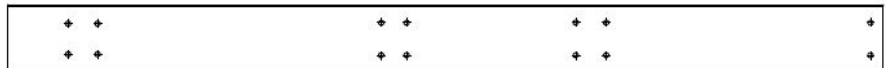

D06 | BEAM - W4L15241
 (2) | 1 3/8"x5 1/4"x67 13/16" (36x134x1723)

INSERT T-NUTS FIRST

TIP:

- SAW DUST CAN BE LEFT BEHIND IN BOLT HOLES. IF YOU HAVE TROUBLE WITH BOLTS ENGAGING, USE A LONG SCREWDRIVER TO REMOVE THE DEBRIS.

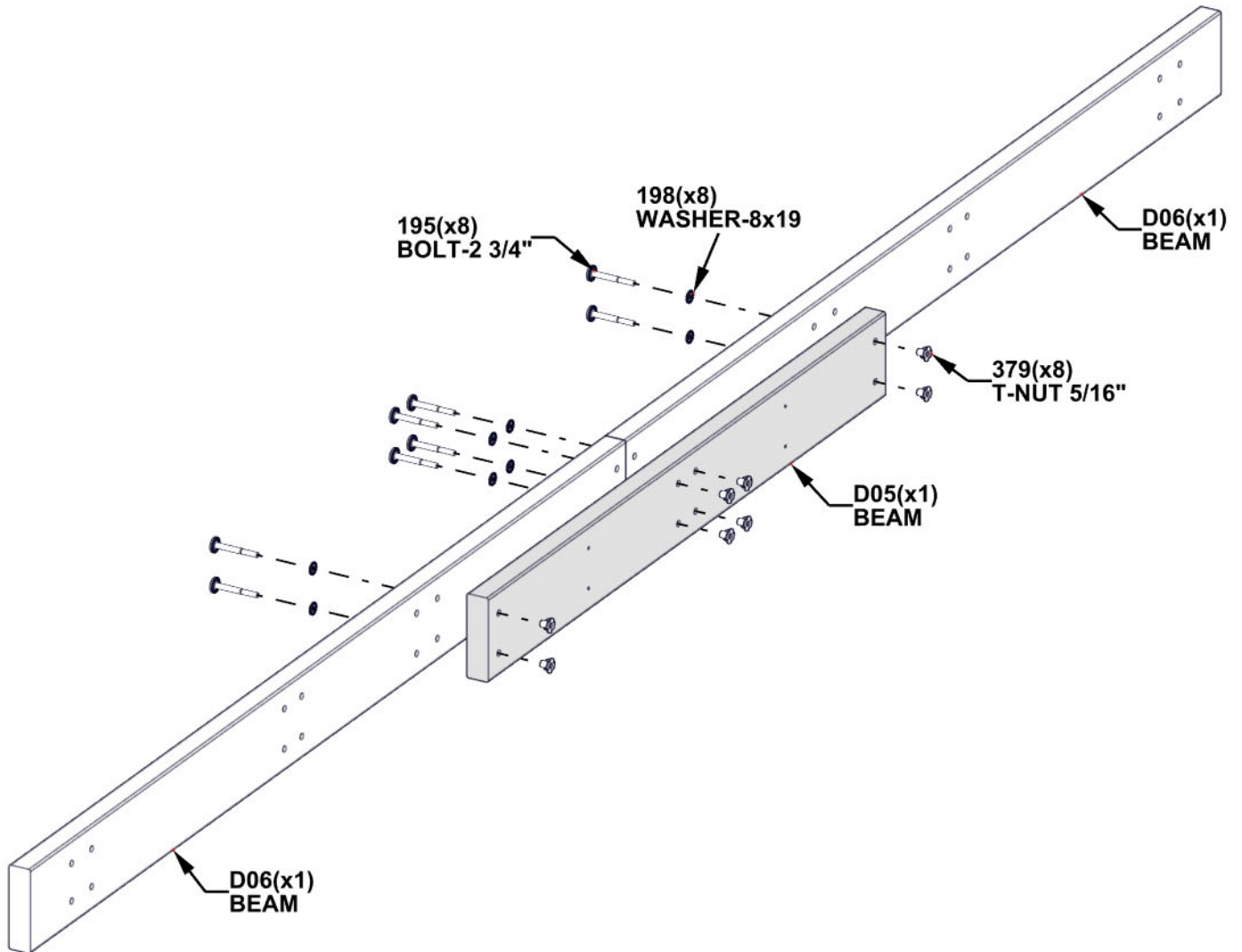

STEP 3 - 12FT BEAM ASSEMBLY



D01 | BEAM- W4L15192
 (2) | 1 3/8"x5 1/4"x45 3/16" (36x134x1148)

QTY	PART NUMBER	DESCRIPTION
4	H100198	WASHER LOCK EXT 8X19 BLK
4	H100195	BOLT WH 5/16x2 3/4 BLK
4	H100379	T-NUT 5/16" BLK

INSERT T-NUTS FIRST

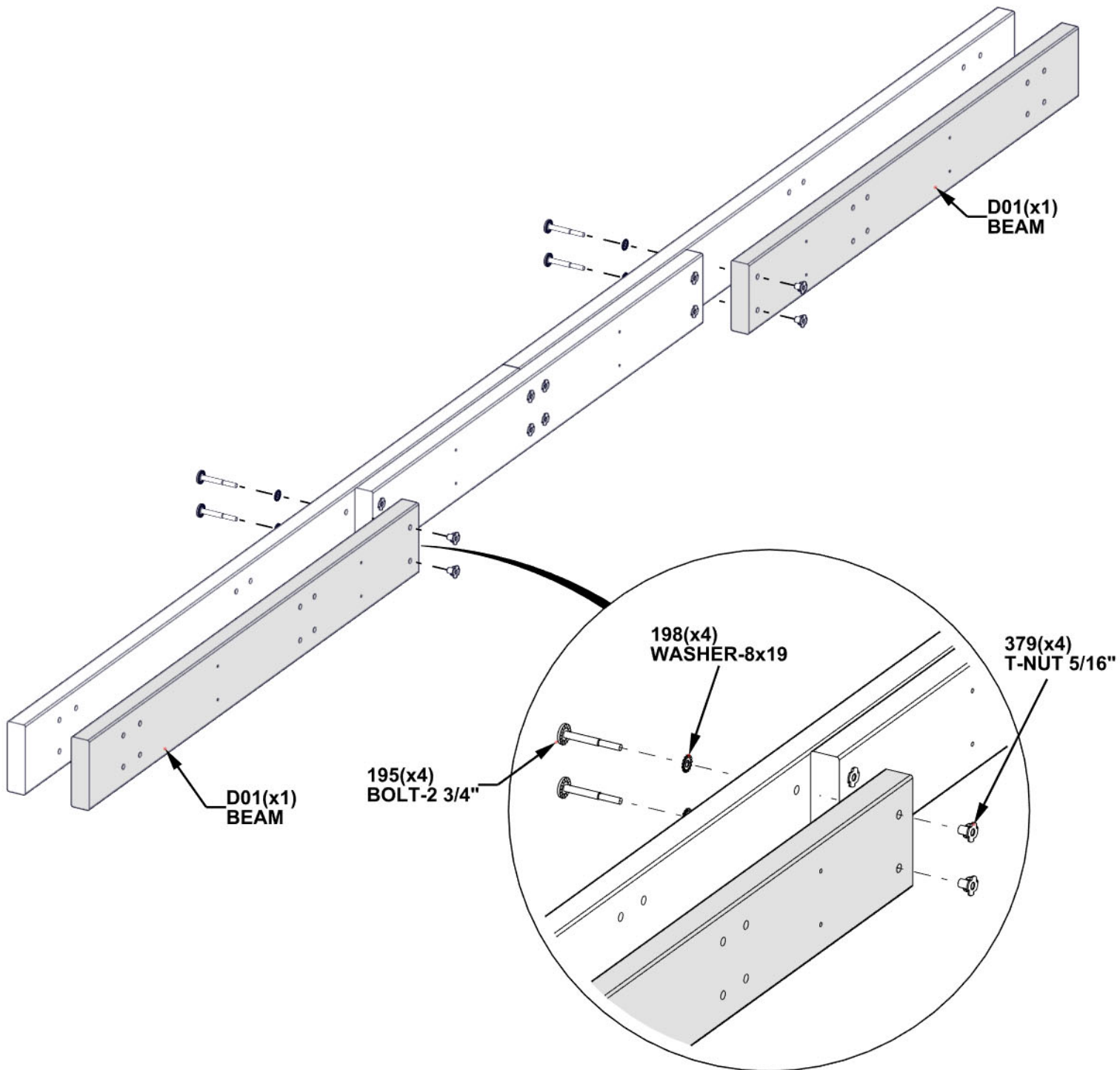

STEP 4 - 12FT BEAM ASSEMBLY

QTY	PART NUMBER	DESCRIPTION
12	H100483	SCREW PFH 8x2 1/4 BLK

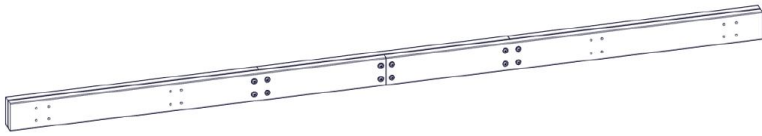

**12 FT BEAM ASSEMBLY
FROM PREVIOUS STEPS**

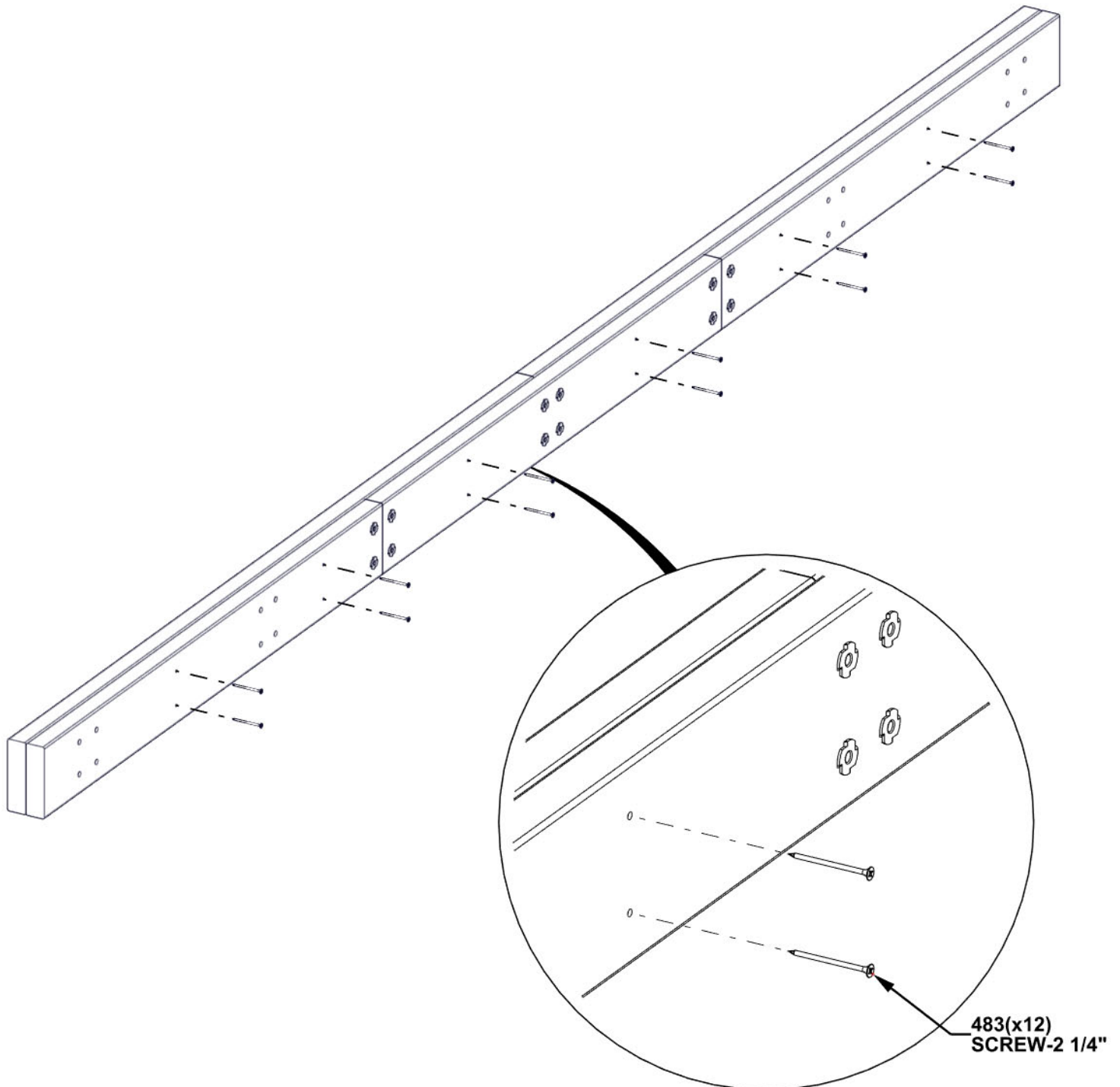

STEP 5 - 12FT BEAM ASSEMBLY

QTY	PART NUMBER	DESCRIPTION
8	H100198	WASHER LOCK EXT 8X19 BLK
8	H100379	T-NUT 5/16" BLK
8	H101058	BOLT WH 5/16x8 3/4 BLK

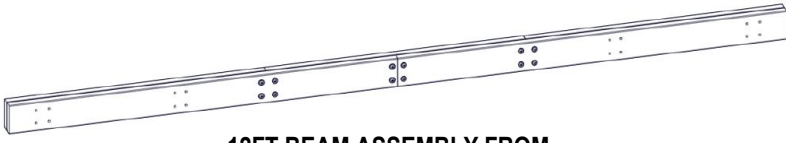

12FT BEAM ASSEMBLY FROM PREVIOUS STEPS

INSERT T-NUTS FIRST

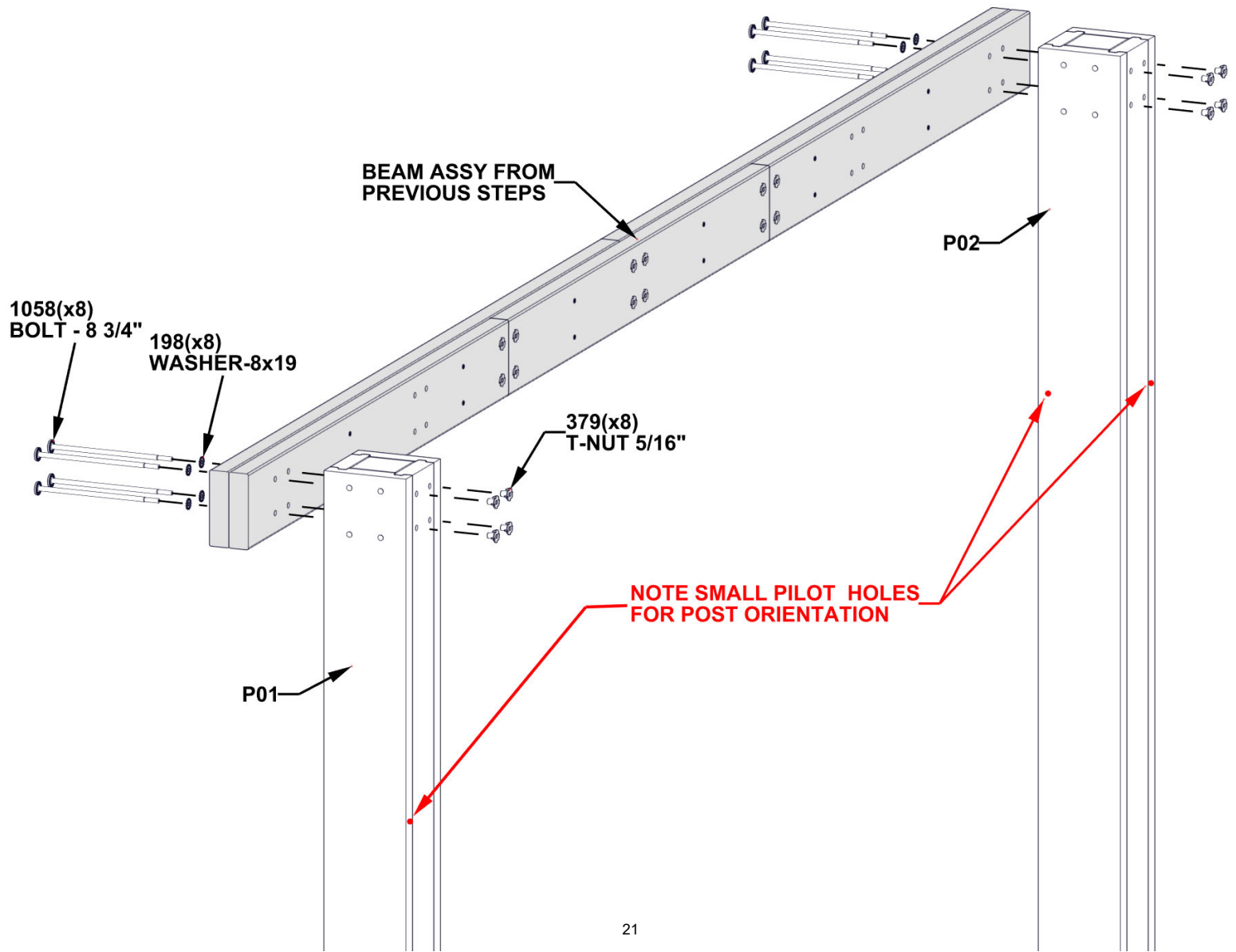

STEP 6 - 12FT BEAM ASSEMBLY

QTY	PART NUMBER	DESCRIPTION
8	H100198	WASHER LOCK EXT 8X19 BLK
8	H100513	BOLT WH 5/16x4 1/4 BLK
8	H100379	T-NUT 5/16" BLK
2	H100405	WASHER LOCK EXT 6X15 BLK
2	H100792	LAG SCREW WH 1/4x3 BLK



C01 | CORBEL- W2A03198
 (2) | 1 7/16"x6 7/16"x35 1/8" (36x163x893)

INSERT T-NUTS FIRST

- TIPS:
- INSERT BOLTS FIRST FOLLOWED BY LAG SCREWS
 - TO AVOID WOOD SPLITTING, MAKE SURE LAG SCREWS GO INTO PILOT HOLES

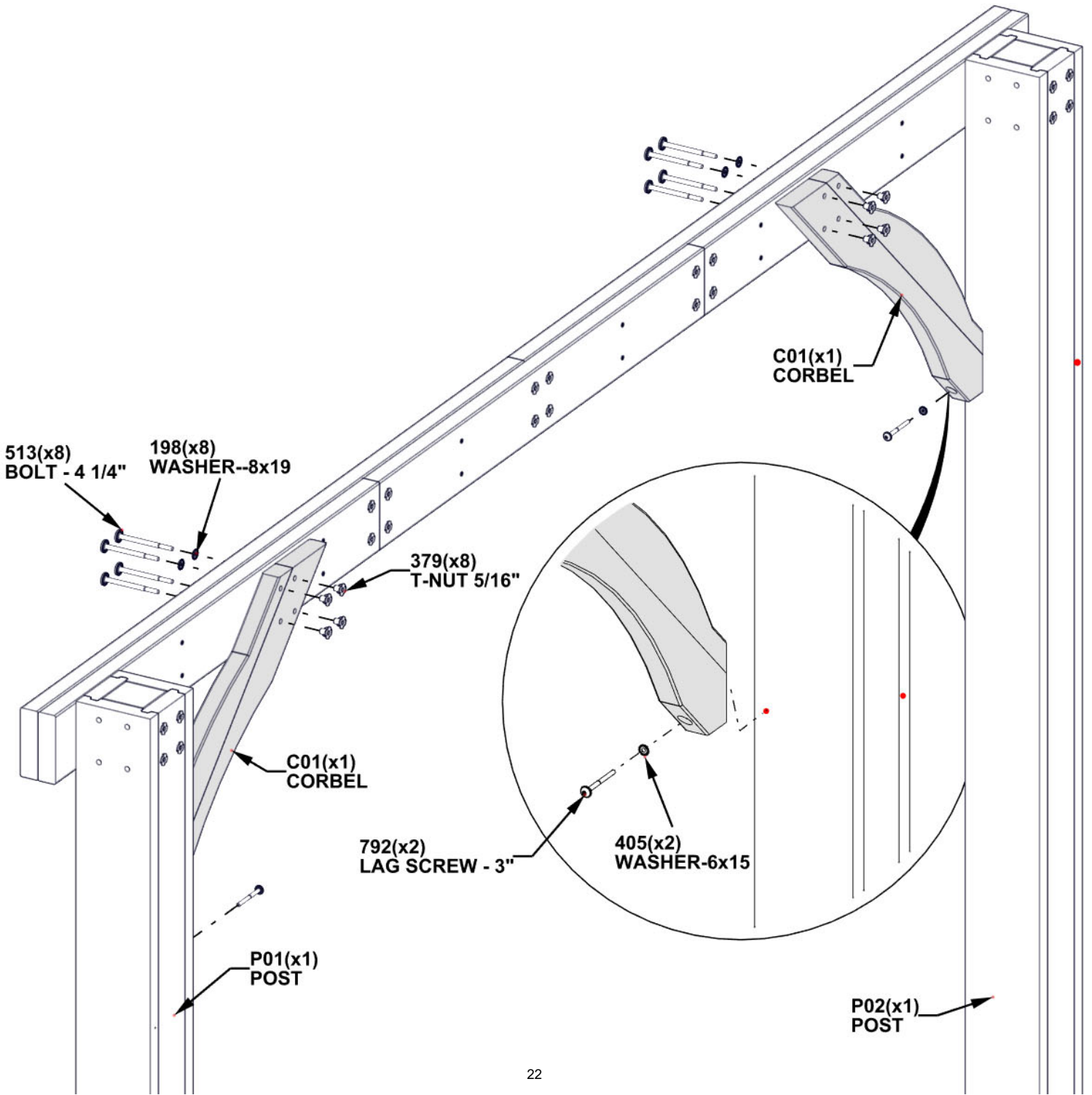

**SET 12FT ASSEMBLY TO THE SIDE
AND REPEAT STEPS 1 THROUGH 6.**

STEP 7 - 14FT BEAM ASSEMBLY

QTY	PART NUMBER	DESCRIPTION
8	H100198	WASHER LOCK EXT 8X19 BLK
8	H100195	BOLT WH 5/16x2 3/4 BLK
8	H100379	T-NUT 5/16" BLK



D03 | BEAM - W4L15193
 (1) | 1 3/8"x5 1/4"x49 15/16" (36x134x1268)



D04 | BEAM - W4L15234
 (2) | 1 3/8"x5 1/4"x77" (36x134x1956)

INSERT T-NUTS FIRST

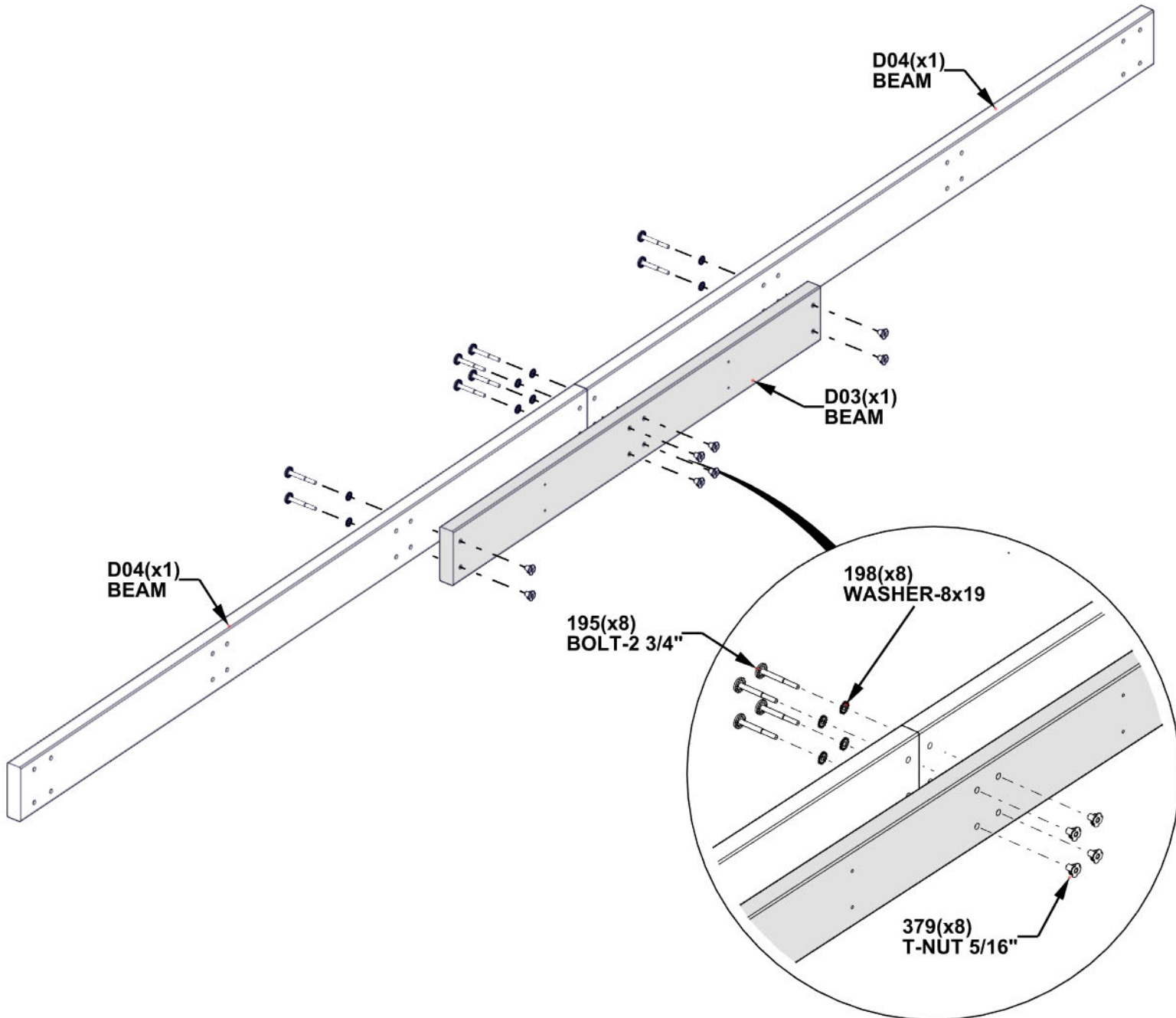

STEP 8 - 14FT BEAM ASSEMBLY

QTY	PART NUMBER	DESCRIPTION
4	H100195	BOLT WH 5/16x2 3/4 BLK
12	H100198	WASHER LOCK EXT 8X19 BLK
12	H100379	T-NUT 5/16" BLK
8	H100513	BOLT WH 5/16x4 1/4 BLK

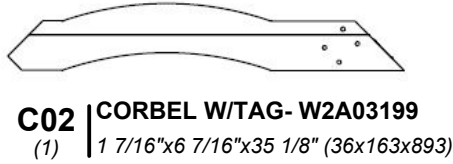
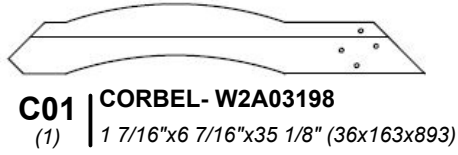

INSERT T-NUTS FIRST

HAND TIGHTEN ONLY

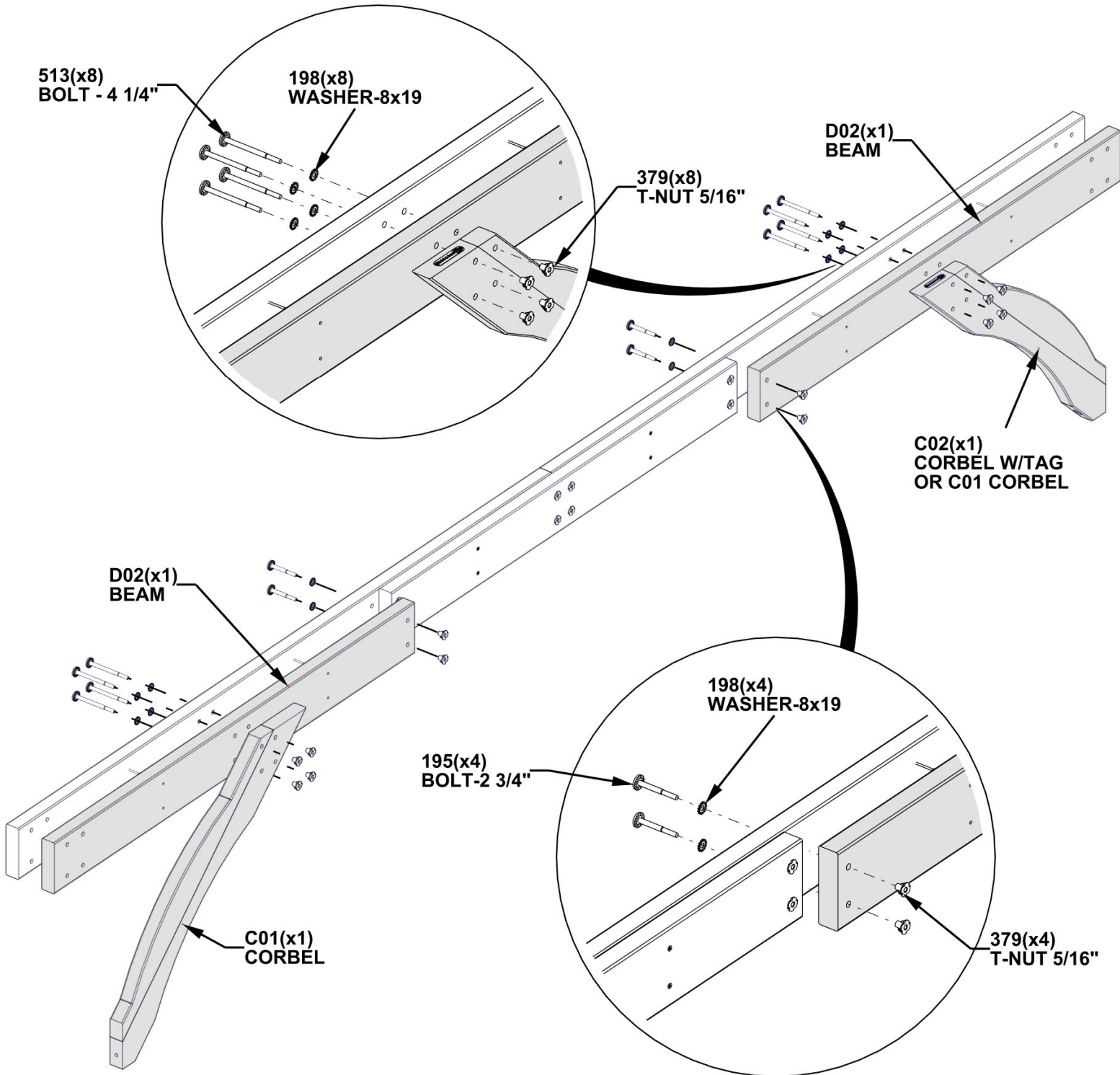

STEP 9 - 14FT BEAM ASSEMBLY

QTY	PART NUMBER	DESCRIPTION
12	H100483	SCREW PFH 8x2 1/4 BLK

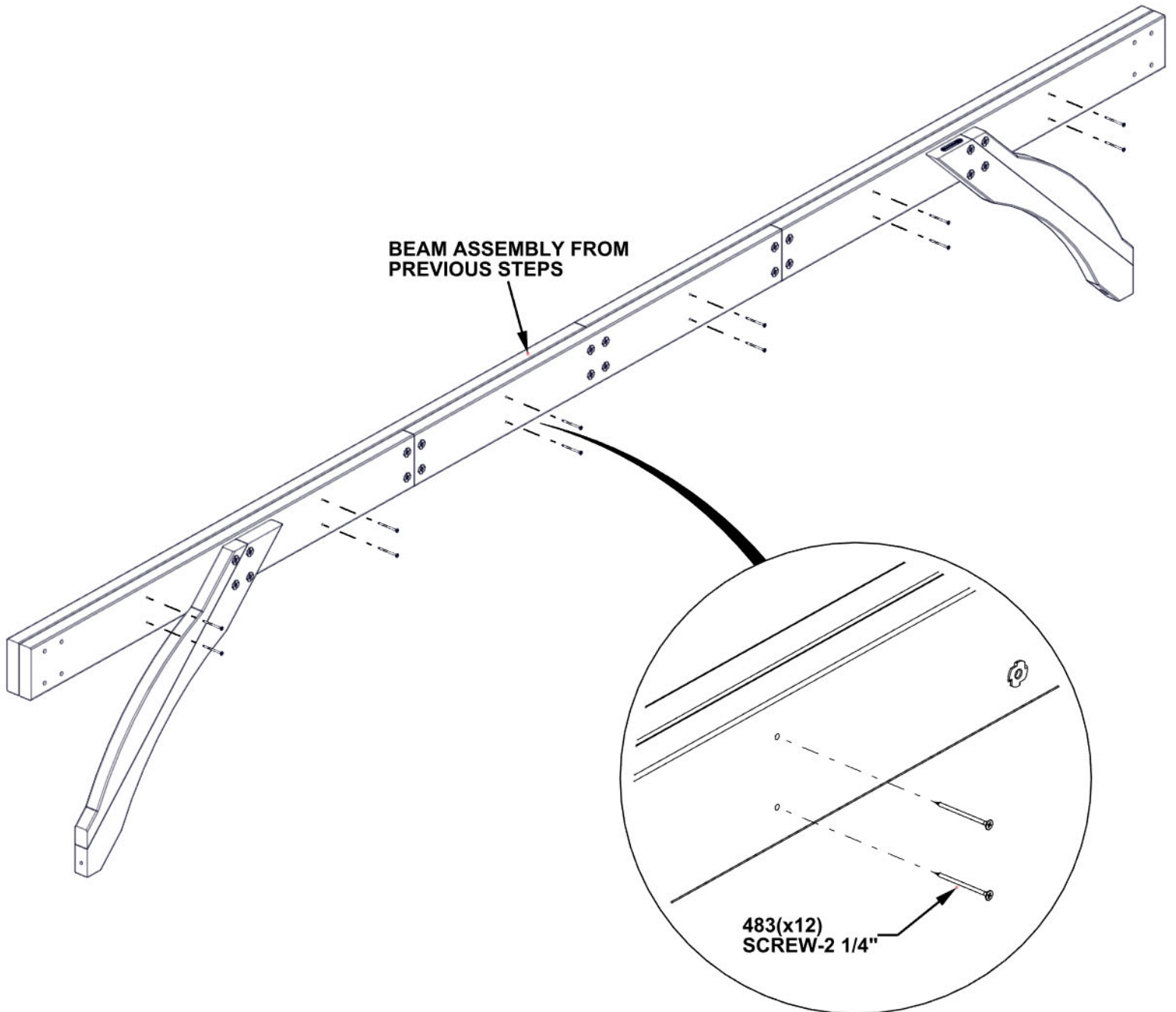
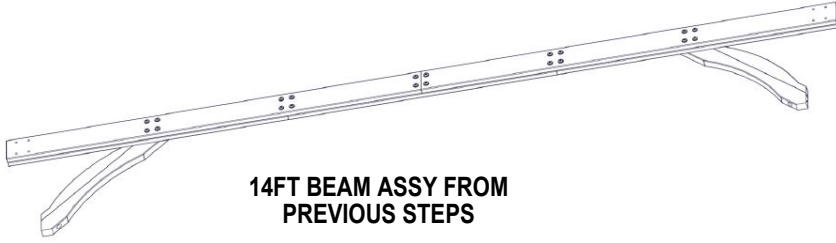

STEP 10 - 14FT BEAM ASSEMBLY

QTY	PART NUMBER	DESCRIPTION
8	H101058	BOLT WH 5/16x8 3/4 BLK
8	H100379	T-NUT 5/16" BLK
8	H100198	WASHER LOCK EXT 8X19 BLK
2	H100792	LAG SCREW WH 1/4x3 BLK
2	H100405	WASHER LOCK EXT 6X15 BLK

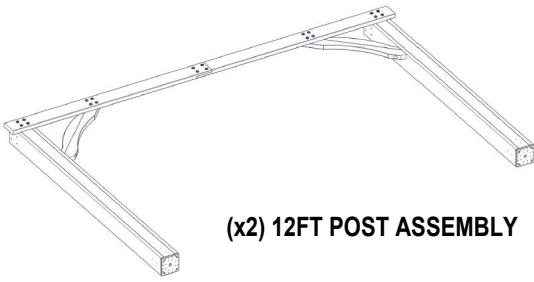

(x2) 12FT POST ASSEMBLY



(x2) 14FT BEAM ASSEMBLY

TIPS:

- THREE PEOPLE ARE HELPFUL FOR THIS STEP.
- MOVE THE 12FT POST ASSEMBLIES TO THEIR FINAL LOCATION WITH SOMEONE HOLDING EACH ASSEMBLY UPRIGHT.
- USING A THIRD PERSON, CONNECT THE 14FT BEAM ASSEMBLY TO THE POSTS TO MAKE THE GAZEBO FRAME.

HAND TIGHTEN ONLY

INSERT T-NUTS FIRST

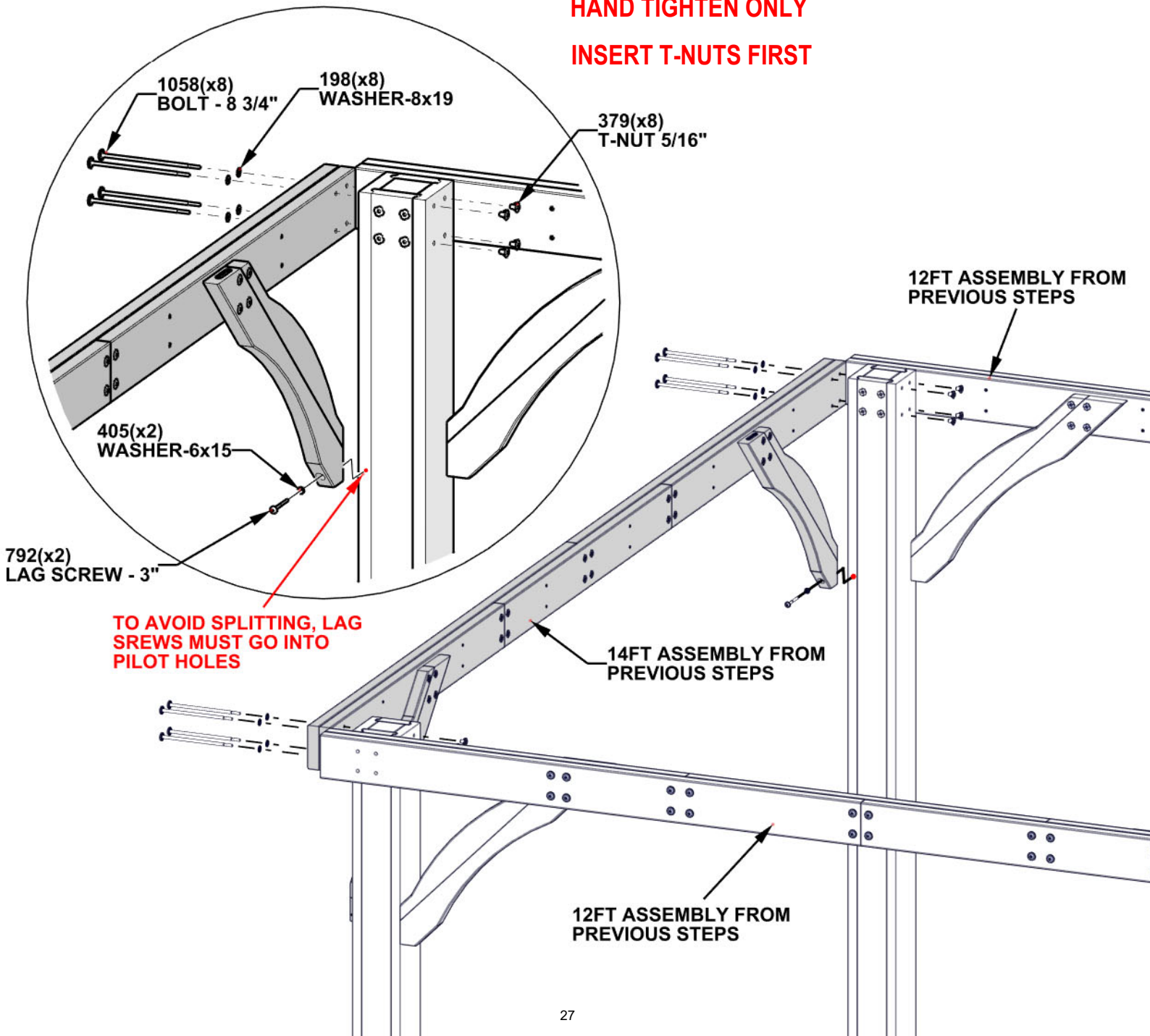

**SET 14FT ASSEMBLY TO THE SIDE
AND REPEAT STEPS 7 THROUGH 10.**

STEP 11

**CRITICAL: SQUARE UNIT BEFORE PROCEEDING TO NEXT STEPS.
ONCE SQUARE, TIGHTEN ALL HARDWARE.**

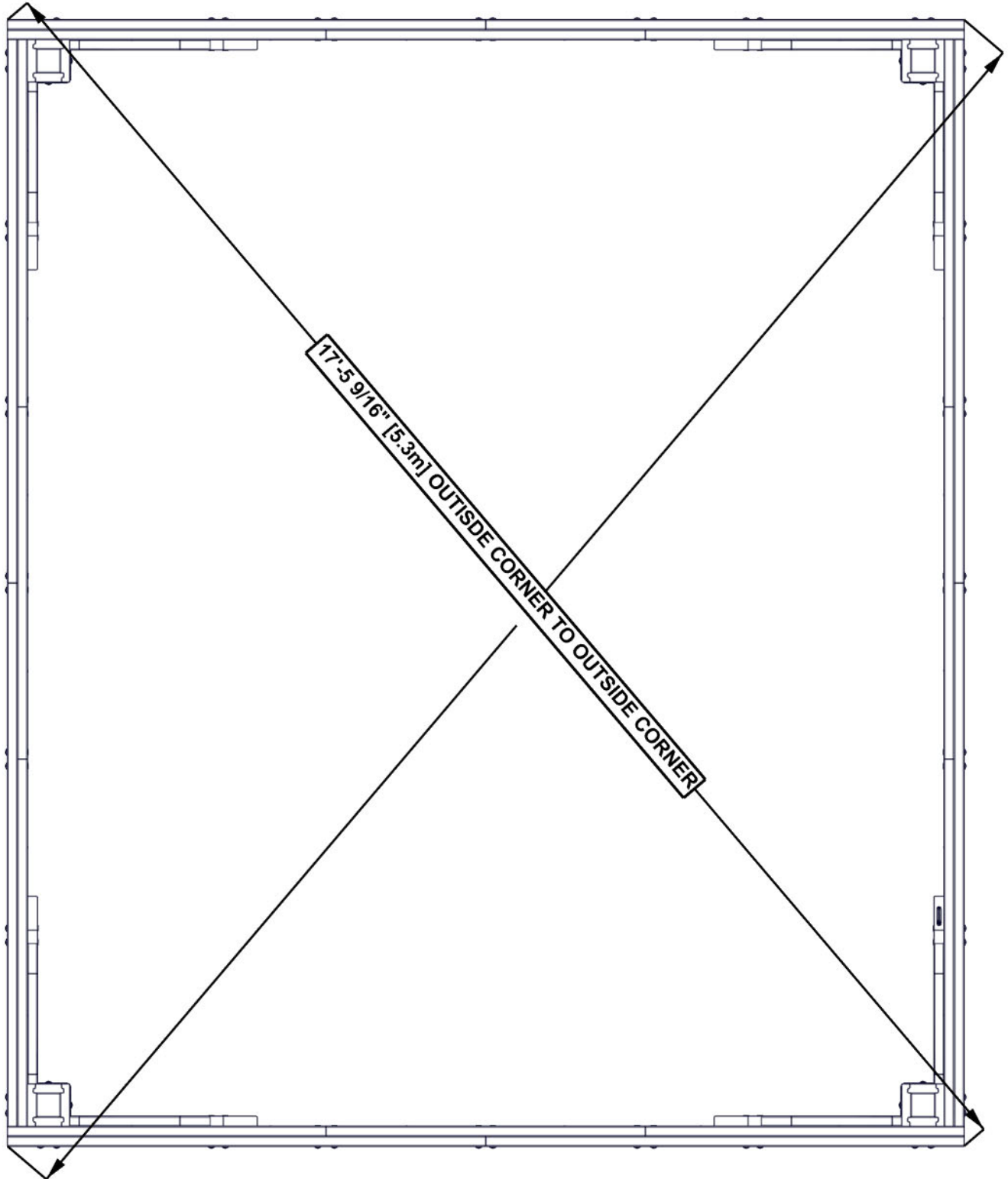

TOP VIEW

STEP 12 - ROOF SUPPORT ASSEMBLY

QTY	PART NUMBER	DESCRIPTION
16	H100460	LAG SCREW WH 1/4x1 BLK



A4M01234
(4) POST CLIP

REPEAT ON ALL FOUR POST

DO NOT OVERTIGHTEN

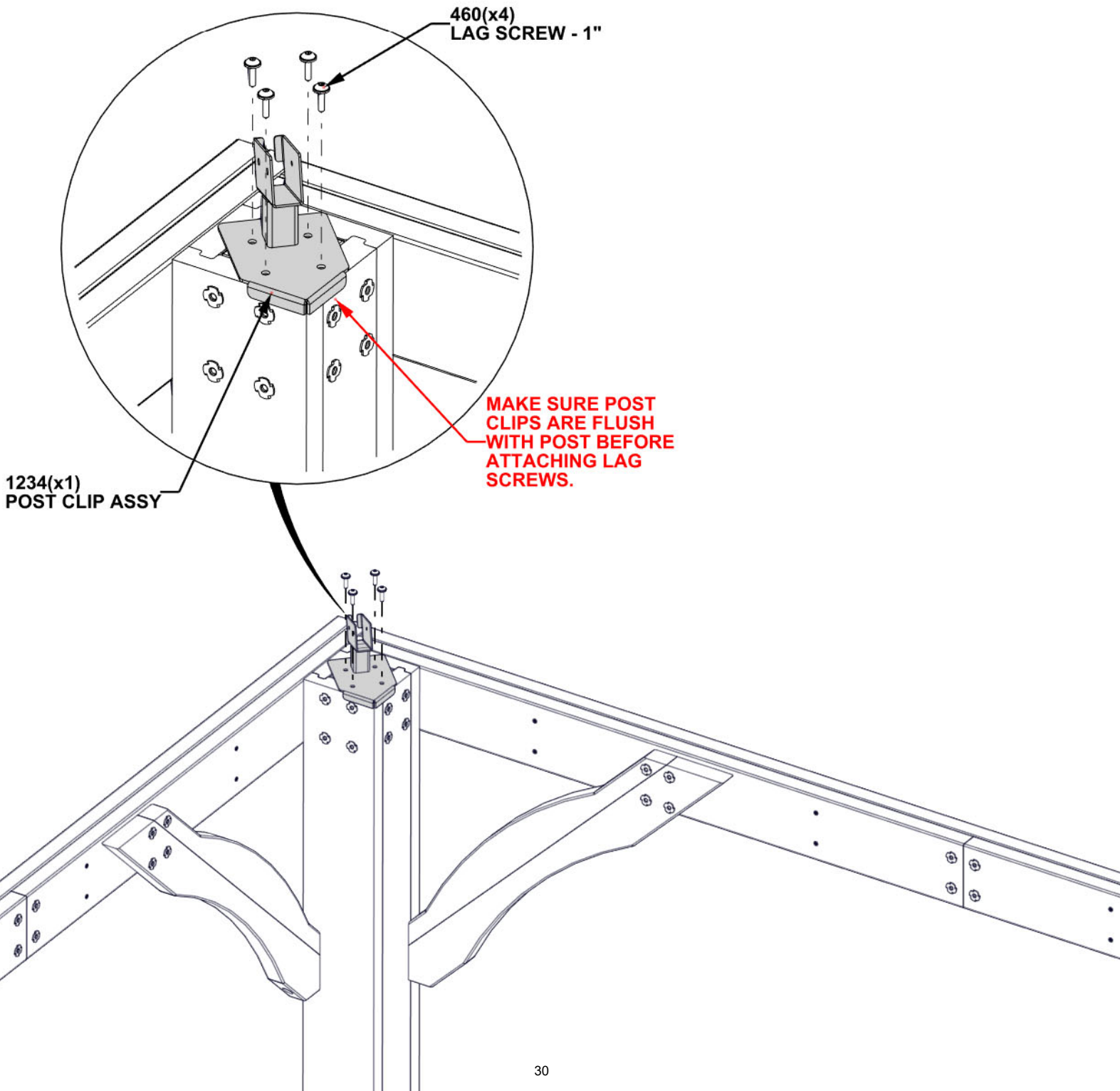

STEP 13 - ROOF SUPPORT ASSEMBLY



H29 ROOF SUPPORT- W4L15160
(1) 1"x3 3/8"x24" (24x86x610)

QTY.	PART NUMBER	DESCRIPTION
2	H100379	T-NUT 5/16" BLK
8	H100385	SCREW PFH 8x1 BLK

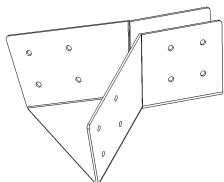

A4M01184 PANEL SUPPORT BRACKET
(2)

INSERT T-NUTS FIRST

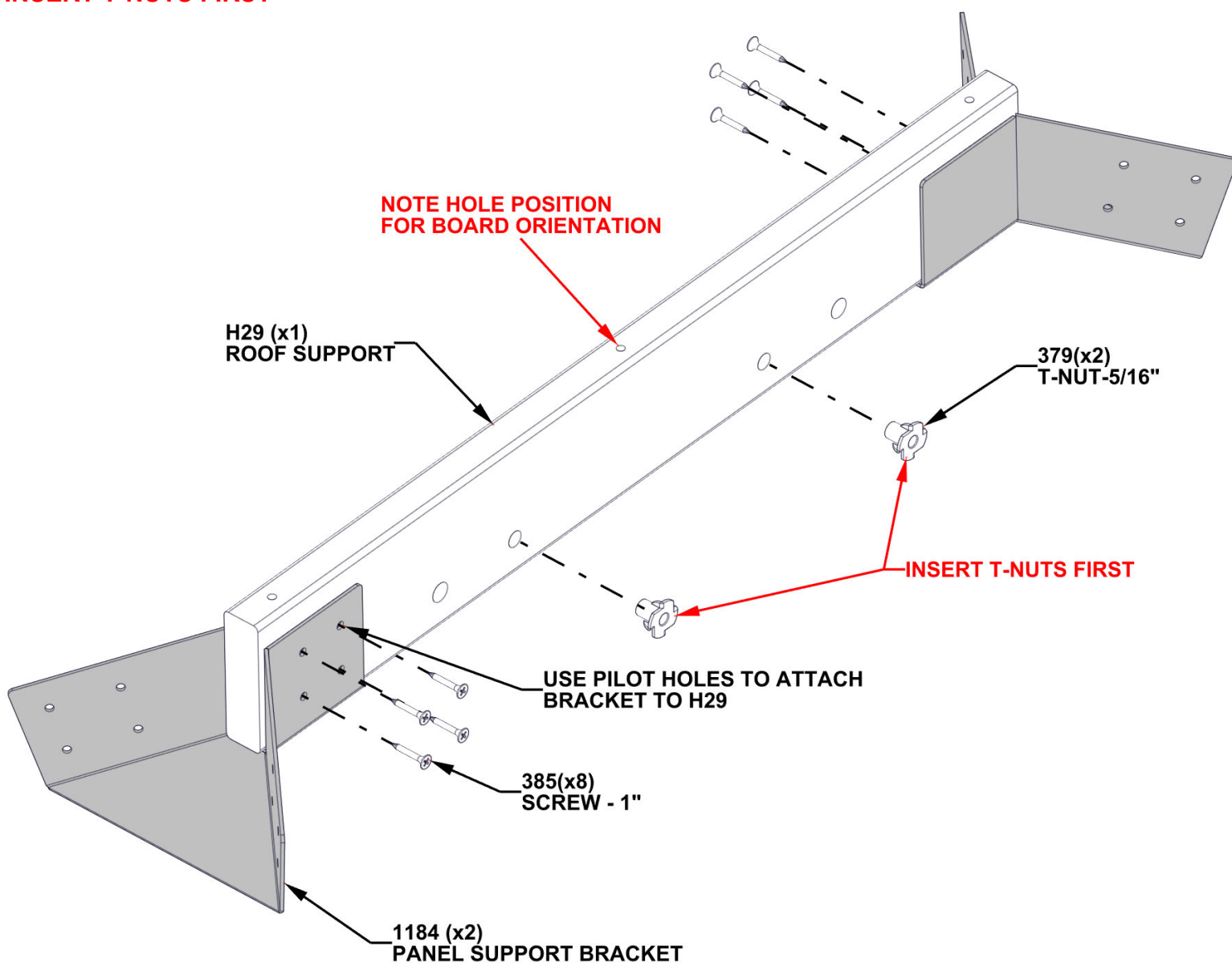

STEP 14 - ROOF SUPPORT ASSEMBLY



H01 | ROOF SUPPORT- W4L15194
(4) 1"x3 3/8"x54 1/8" (24x86x1374)

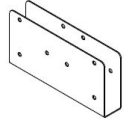

A4M01237 | ROOF SUPPORT SPLICE CLIP
(4)

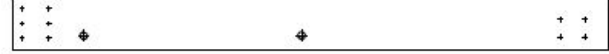

H04 | ROOF SUPPORT - W4L15201
(4) 1"x3 3/8"x38 13/16" (24x86x986)

QTY.	PART NUMBER	DESCRIPTION
4	H100379	T-NUT 5/16" BLK
48	H100385	SCREW PFH 8x1 BLK

REPEAT FOUR TIMES

INSERT T-NUTS FIRST

IMPORTANT! THERE WILL BE FOUR OF THESE ASSEMBLIES. ASSEMBLE (2) WITH T-NUT ON SIDE AS SHOWN BELOW. ASSEMBLE THE OTHER (2) WITH T-NUT IN SAME HOLE BUT ON OTHER SIDE OF BOARD H04.

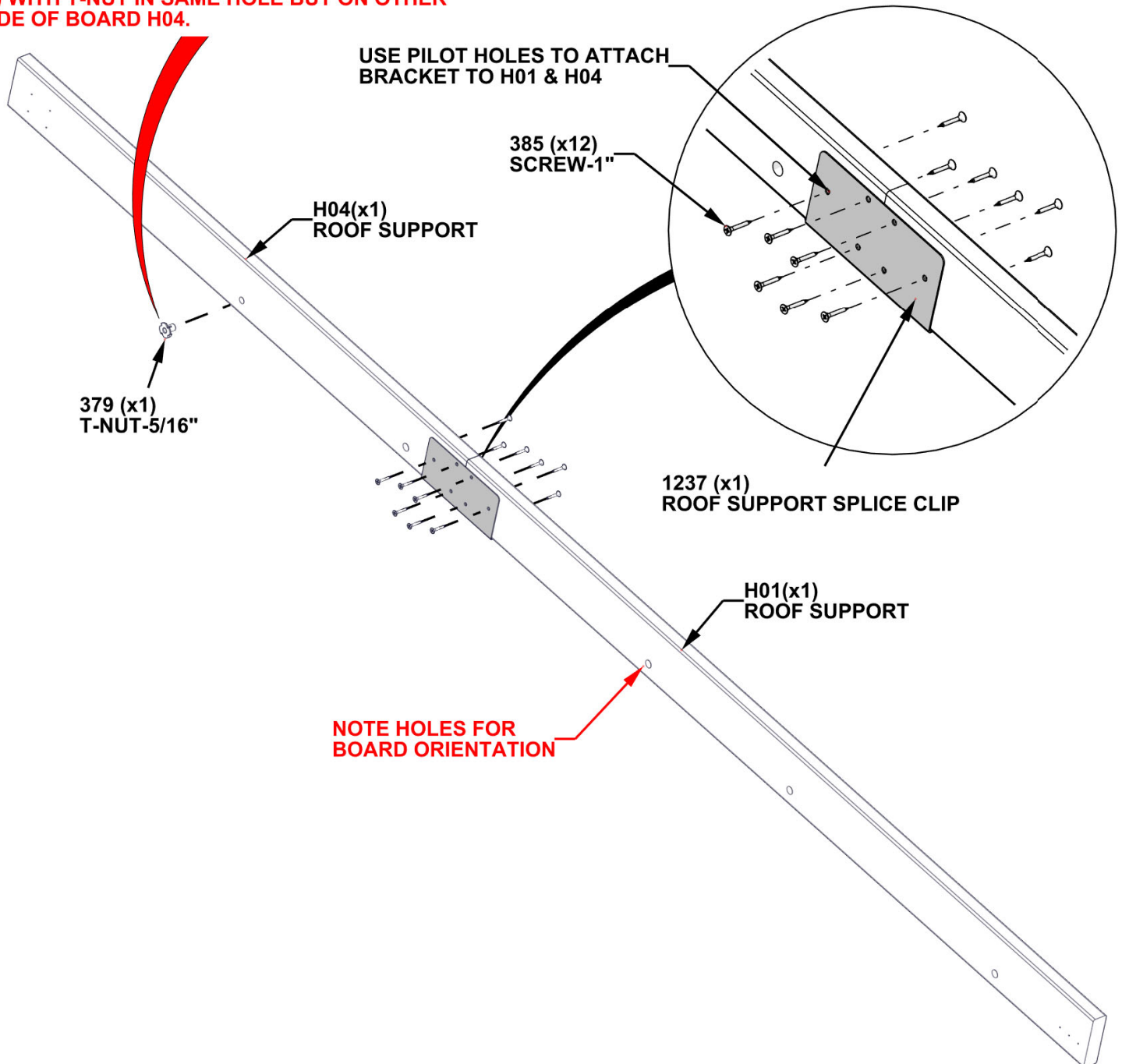

STEP 15 - ROOF SUPPORT ASSEMBLY

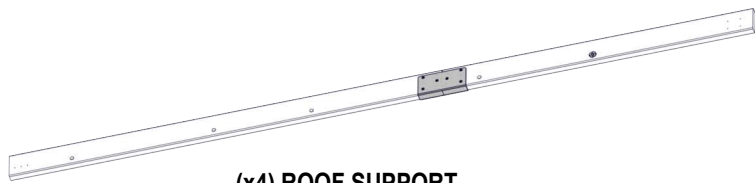

(x4) ROOF SUPPORT
FROM PREVIOUS STEP

QTY.	PART NUMBER	DESCRIPTION
16	H100385	SCREW PFH 8x1 BLK

REPEAT ON OPPOSITE END OF ROOF SUPPORT BOARD

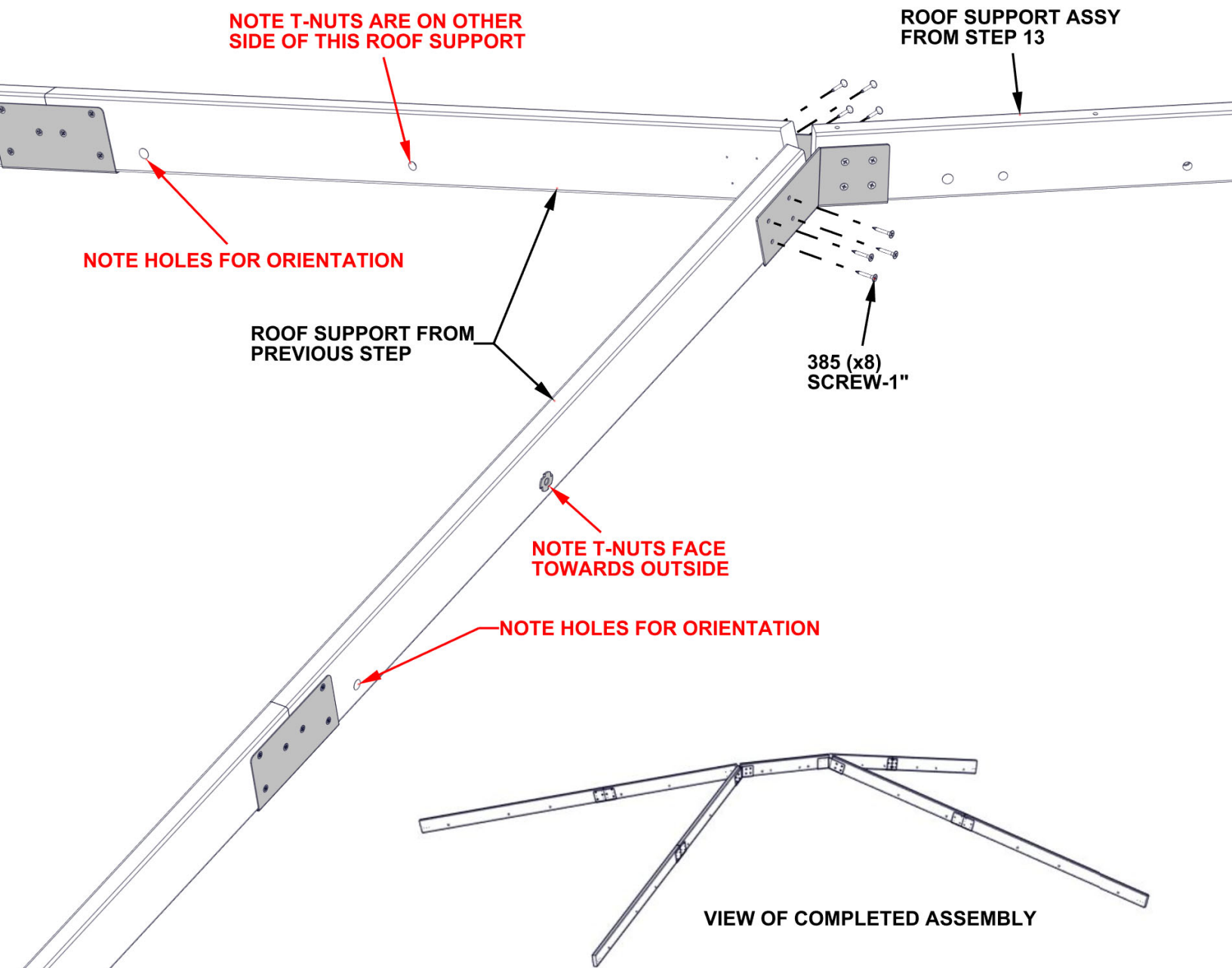

STEP 16 - ROOF SUPPORT ASSEMBLY

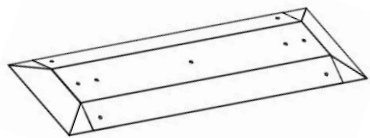

A4M02886 | RIDGE PEAK CAP
(1)

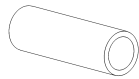

A4M01205 | METAL SPACER
(3)

QTY.	PART NUMBER	DESCRIPTION
3	H100792	LAG SCREW WH 1/4x3 BLK
3	H101034	WEATHER PROOFING WASHER

TIPS:

- REMOVE PROTECTIVE BLUE FILM BEFORE ASSEMBLY

WARNING: GLOVES ARE RECOMMENDED WHEN HANDLING STEEL ROOF PIECES

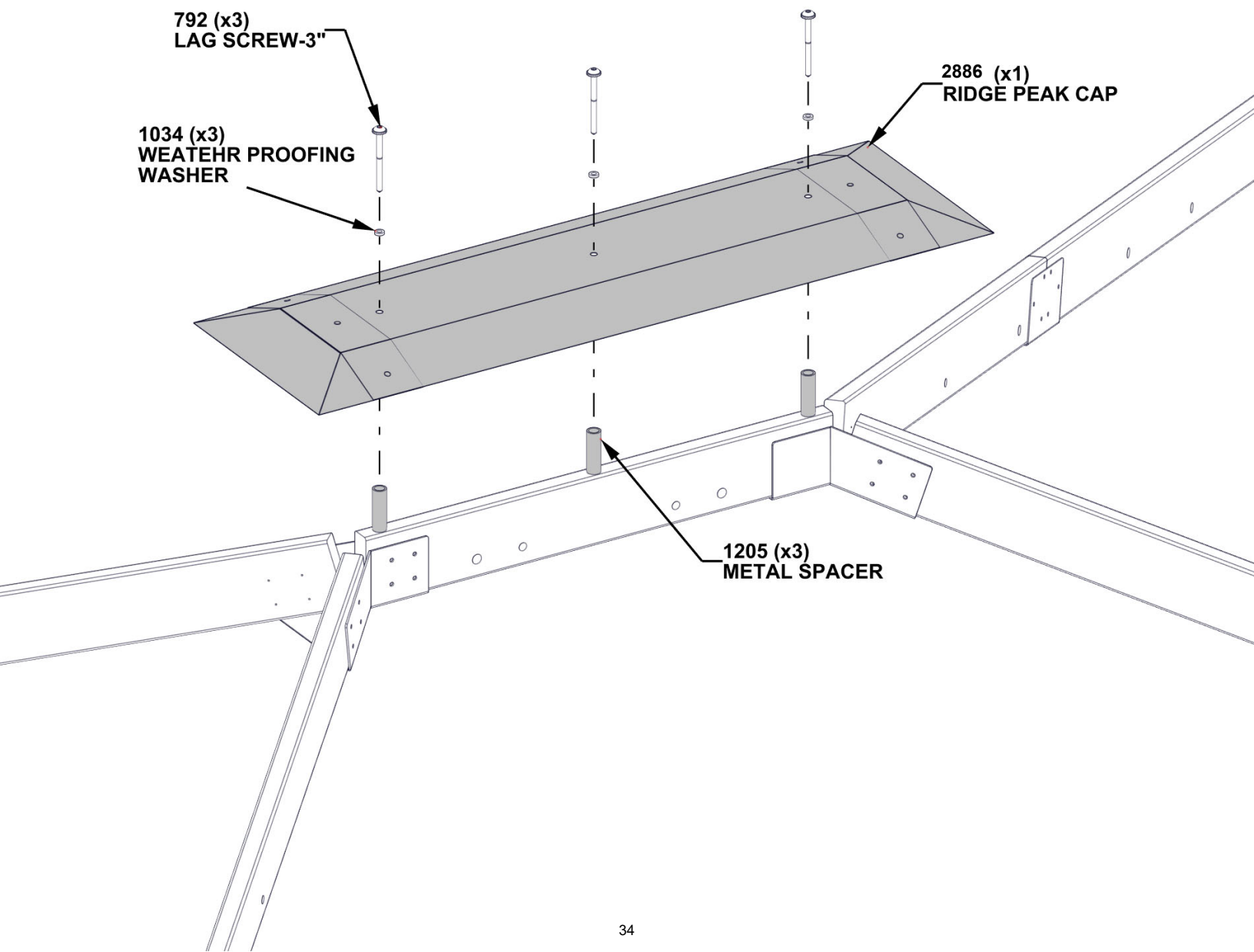

STEP 17 - SUPPORT ASSEMBLY

- THREE PEOPLE ARE HELPFUL FOR THIS STEP.
- POSITION A PERSON ON A LADDER IN THE CENTER OF THE BASE.
- LIFT ROOF SUPPORT UP AND OVER THE 14FT SIDE AND INSERT INTO CORNER POST CLIPS.

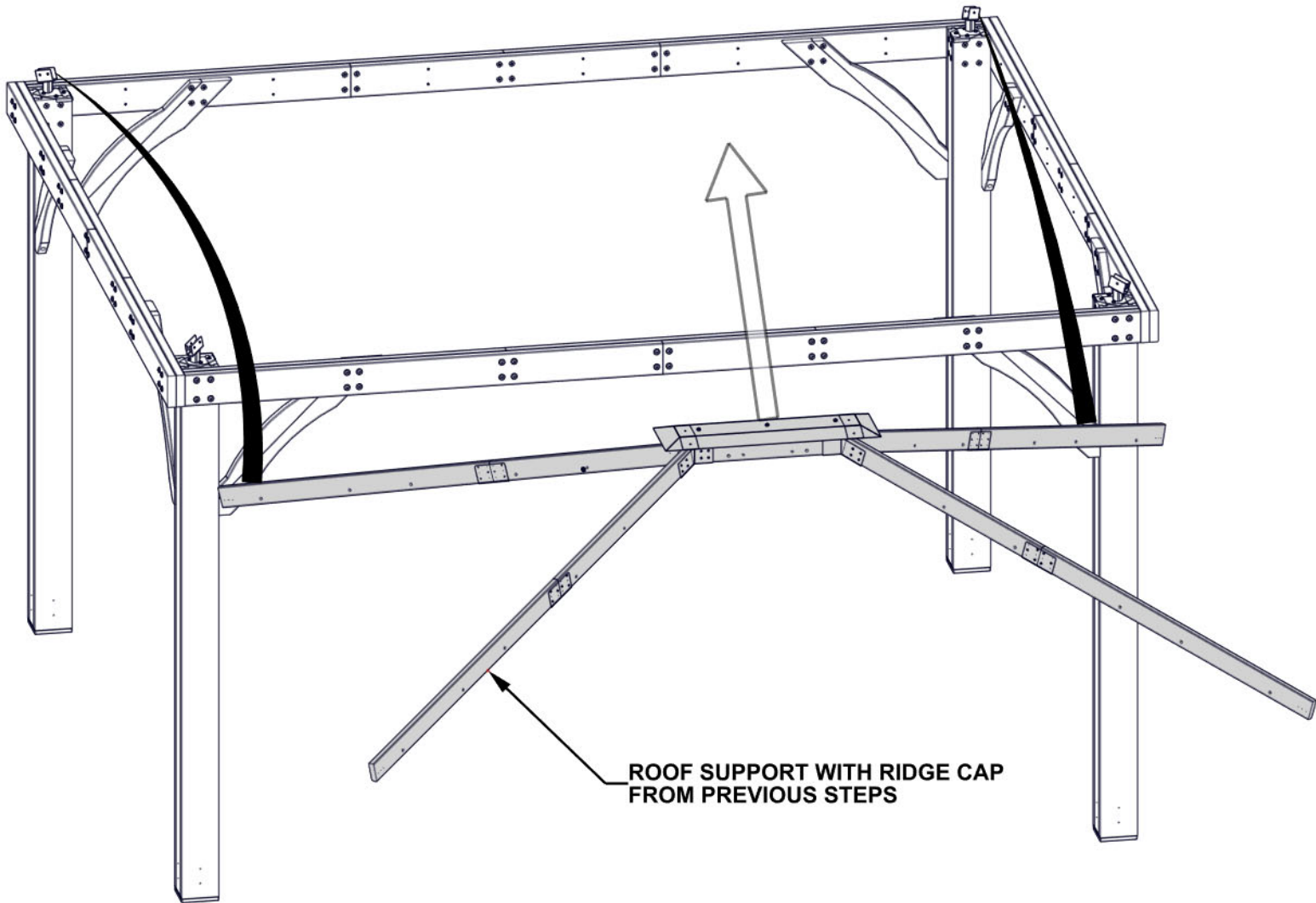

STEP 18 - ROOF SUPPORT ASSEMBLY

QTY	PART NUMBER	DESCRIPTION
12	H100385	SCREW PFH 8x1 BLK

REPEAT ON ALL POSTS

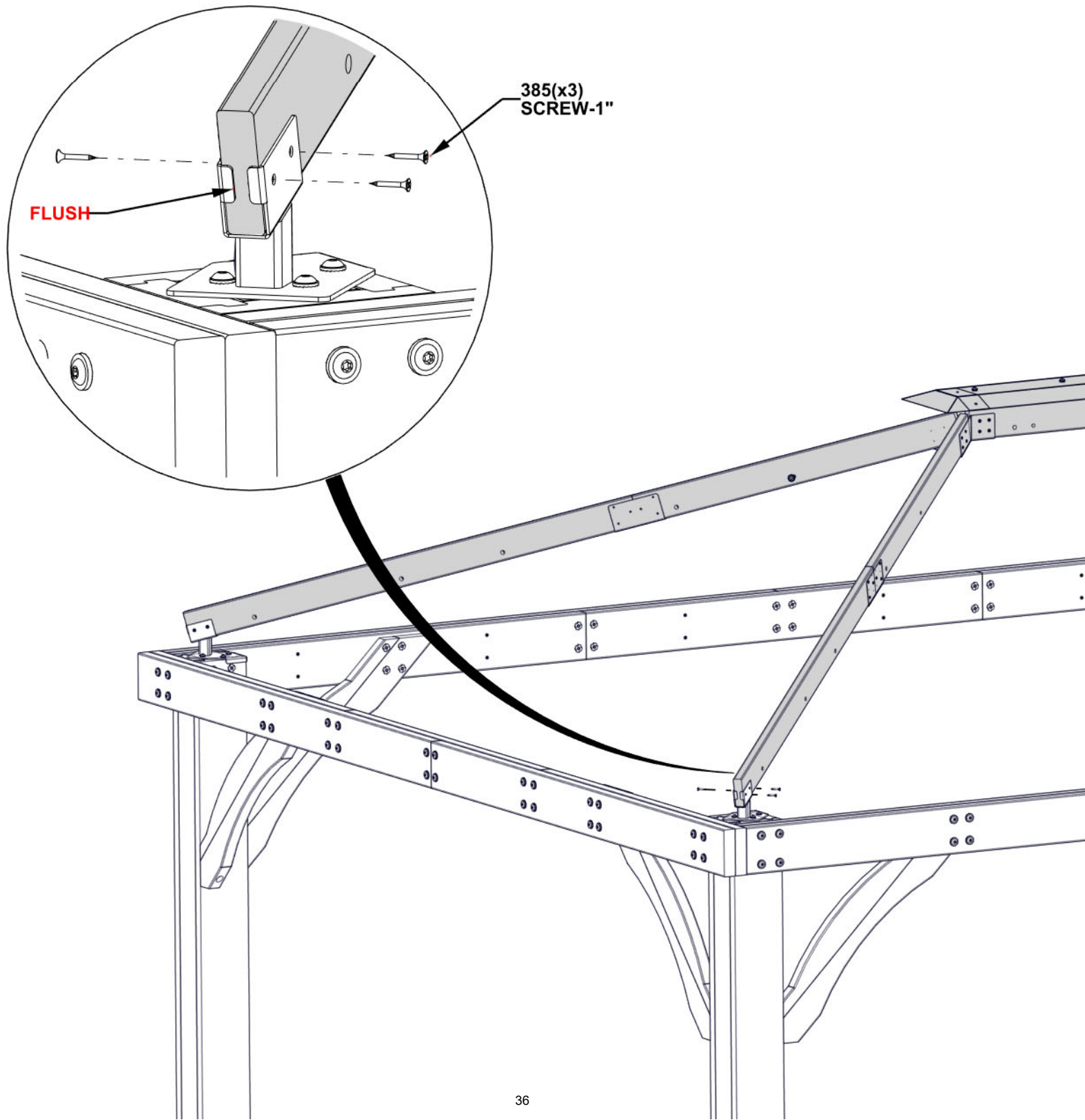

STEP 19 - 14FT ROOF PANEL ASSEMBLY



H03 | ROOF JOIST - W4L15197
(1) | 1"x3 3/8"x22 7/8" (24x86x580)

QTY.	PART NUMBER	DESCRIPTION
4	H100171	BOLT WH 1/4x1 BLK
4	H100398	T-NUT 1/4" BLK

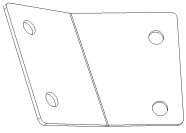

A4M01193 | PANEL BRACKET
(1)

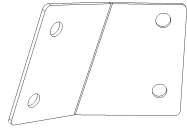

A4M01191 | PANEL BRACKET
(1)

**INSERT T-NUTS FIRST
HAND TIGHTEN ONLY**

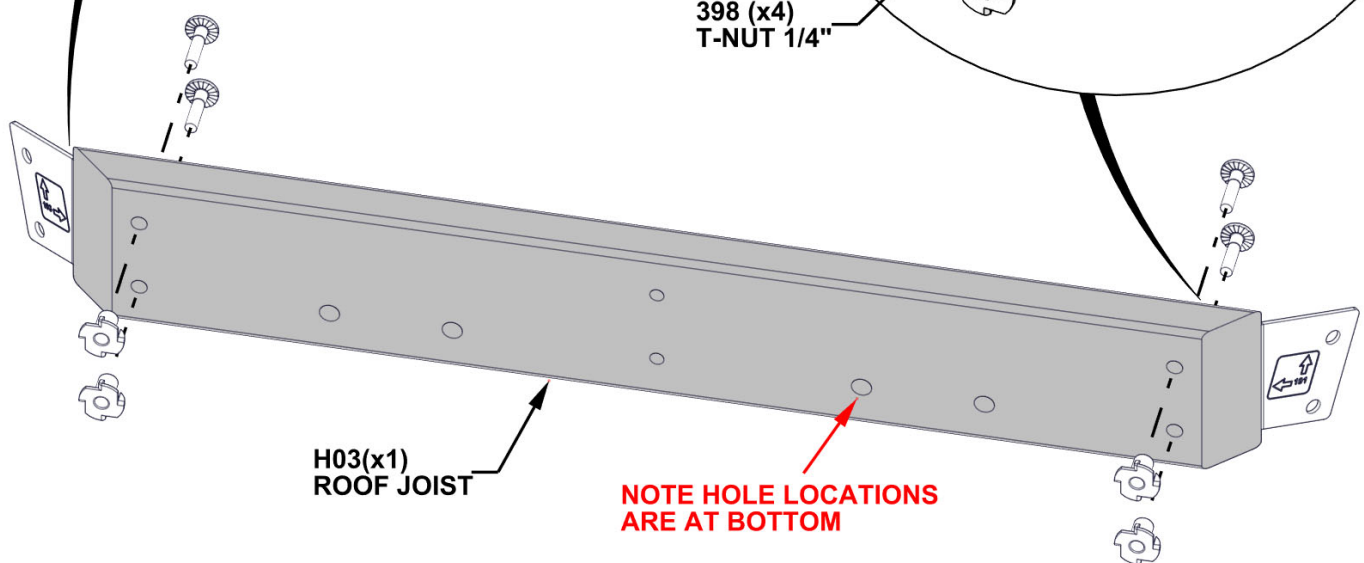
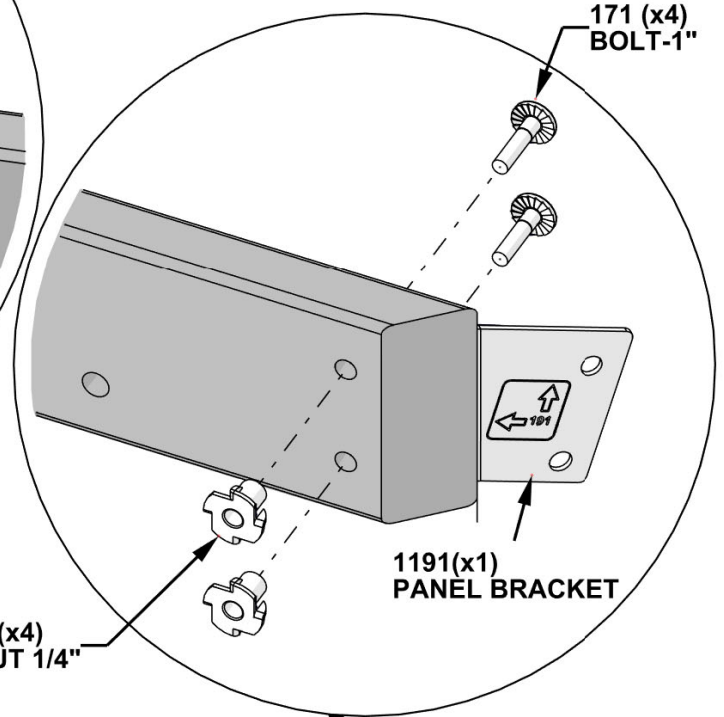
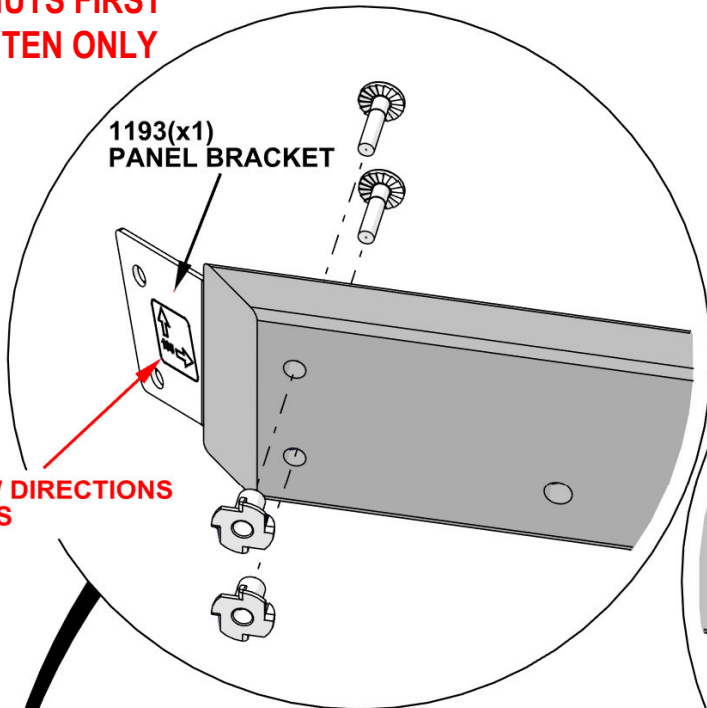

STEP 20 - 14FT ROOF PANEL ASSEMBLY

H02 | ROOF JOIST - W4L15195
 (1) | 1"x3 3/8"x61 1/4" (24x86x1556)

H09 | ROOF JOIST - W4L15213
 (1) | 1"x3 3/8"x61 1/4" (24x86x1556)

H05 | ROOF JOIST - W4L15202
 (1) | 1"x3 3/8"x44 9/16" (24x86x1132)

QTY.	PART NUMBER	DESCRIPTION
4	H100171	BOLT WH 1/4x1 BLK
24	H100385	SCREW PFH 8x1 BLK
4	H100398	TNUT-1/4" BLK

H10 | ROOF JOIST - W4L15214
 (1) | 1"x3 3/8"x44 9/16" (24x86x1132)

A4M01237 | ROOF SUPPORT
 (2) | SPLICE CLIP

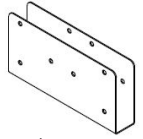

INSERT T-NUTS FIRST

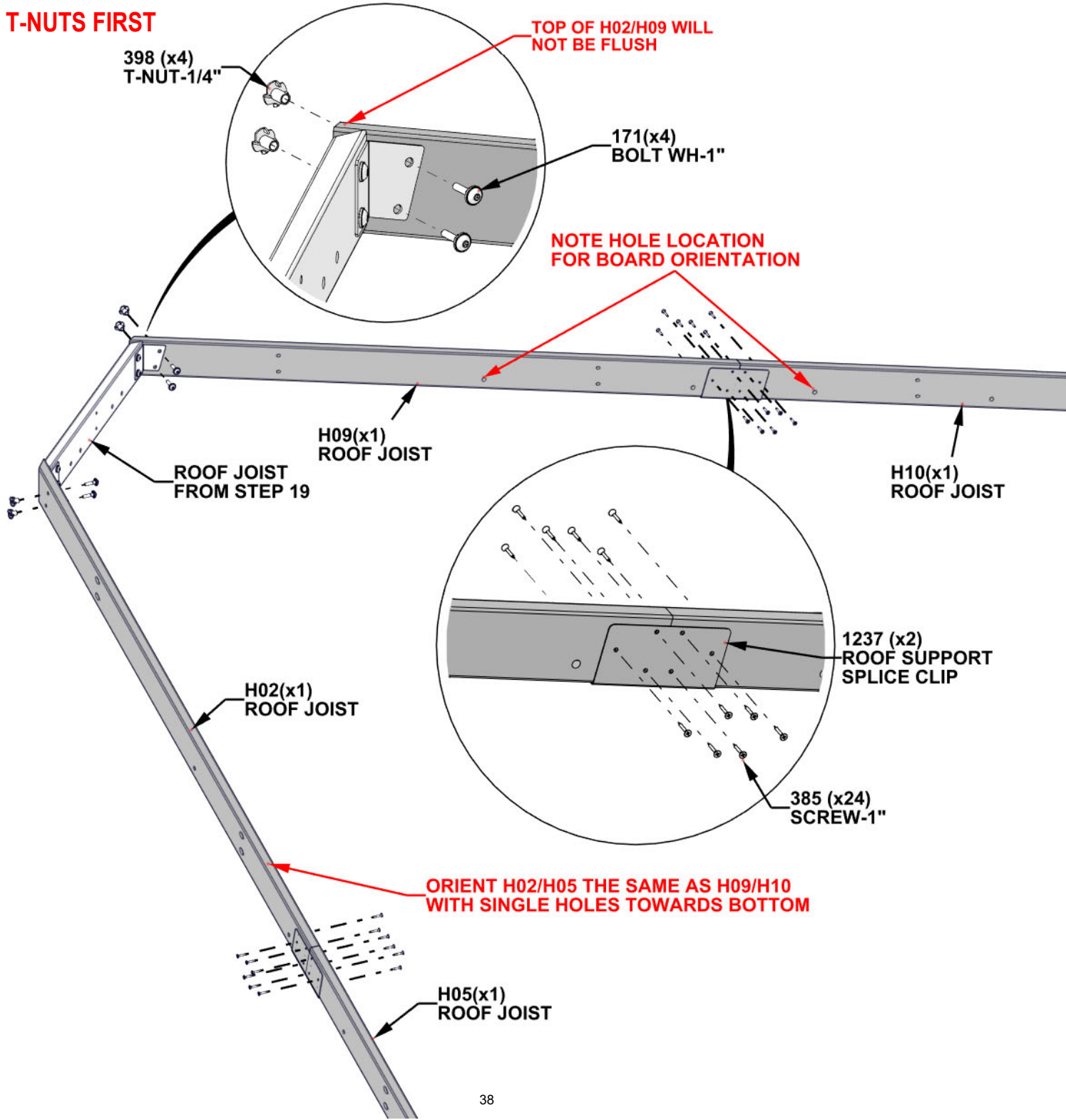

STEP 21 - 14FT ROOF PANEL ASSEMBLY

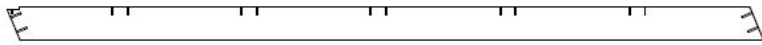

E01 RAFTER- W4L15196
(1) 1 3/8"x3 3/8"x76 3/4" (36x86x1949)



E02 RAFTER- W4L15198
(1) 1 3/8"x3 3/8"x67 5/8" (36x86x1717)

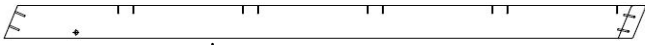

E08 RAFTER - W4L15210
(1) 1 3/8"x3 3/8"x67 5/8" (36x86x1717)



E09 RAFTER - W4L15211
(1) 1 3/8"x3 3/8"x44 1/16" (36x86x1119)

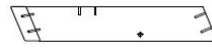

E04 RAFTER- W4L15200
(1) 1 3/8"x3 3/8"x20 1/2" (36x86x520)



E03 RAFTER- W4L15199
(1) 1 3/8"x3 3/8"x44 1/16" (36x86x1119)

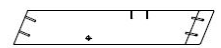

E10 RAFTER- W4L15212
(1) 1 3/8"x3 3/8"x20 1/2" (36x86x520)

QTY.	PART NUMBER	DESCRIPTION
14	H101030	SCREW 2" CONFIRMAT BLK

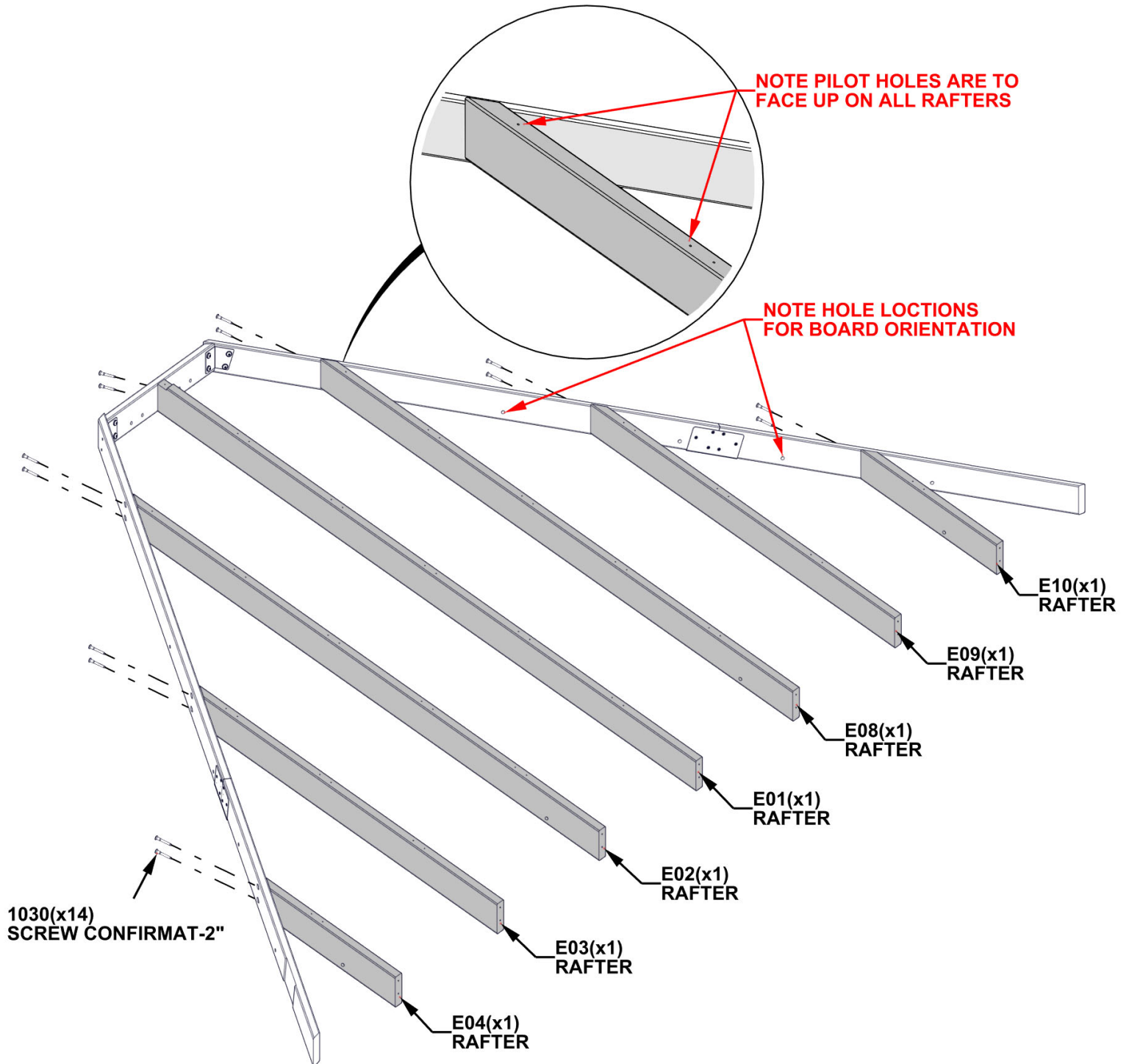

STEP 22A - 14FT ROOF PANEL ASSEMBLY

QTY.	PART NUMBER	DESCRIPTION
4	H100382	SCREW PFH 8x1 3/4 BLK
14	H101030	SCREW 2" CONFIRMAT BLK



Q02 | ROOF JOIST- W4L15215
 (2) | 1"x4 7/16"x84 1/4" (24x112x2140)

TIP:

- RAFTERS MAY NEED TO BE LOOSENED TO ATTACH Q02 TO H05/H10

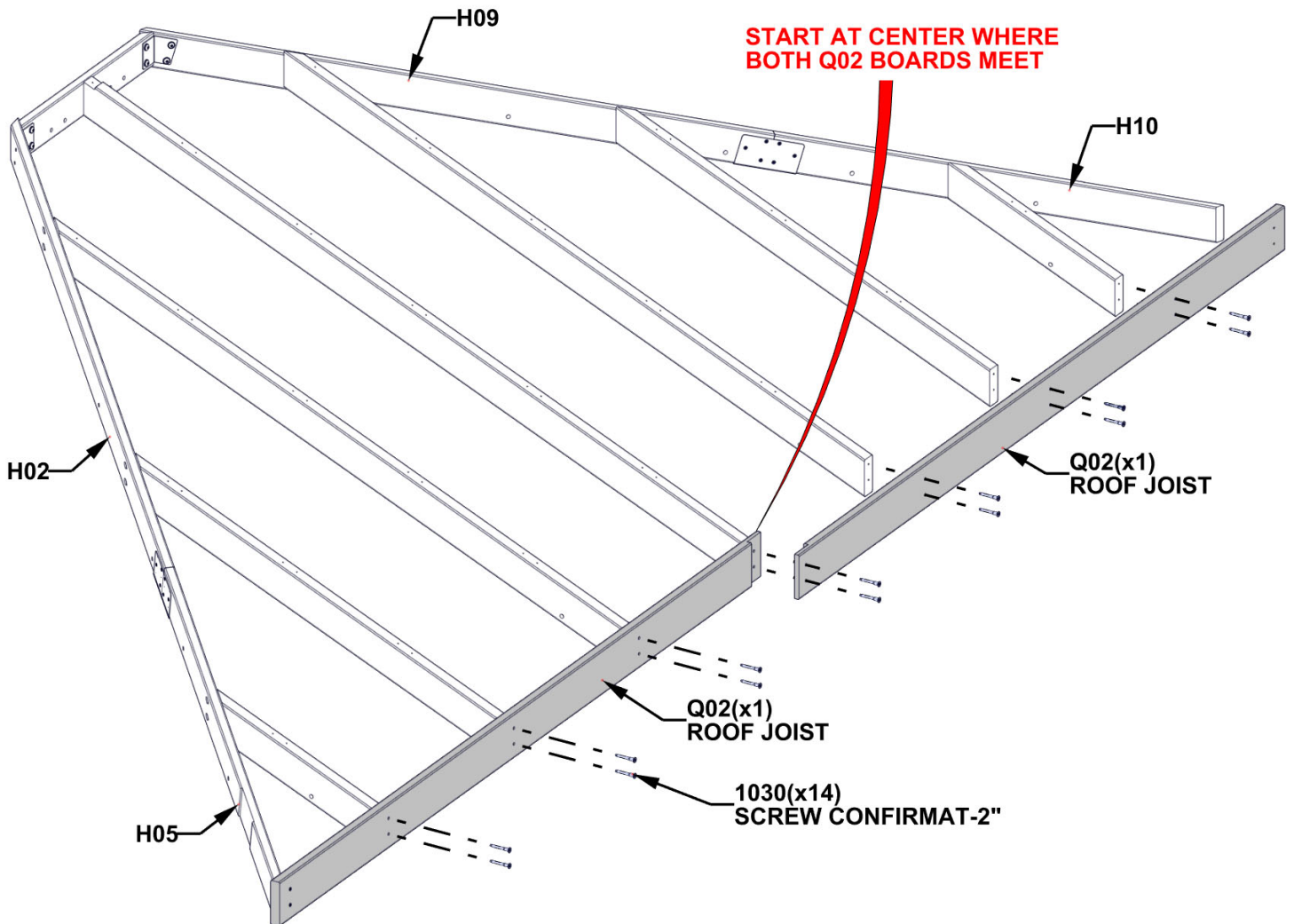

STEP 22B - 14FT ROOF PANEL ASSEMBLY

TIPS:

- USING THE Q02 BOARD AS A GUIDE AND A 1/8" DRILL BIT, DRILL PILOT HOLES INTO THE H05 BOARD USING THE DIMENSION BELOW.
- REPEAT ON OPPOSITE END WITH H10 BOARD.

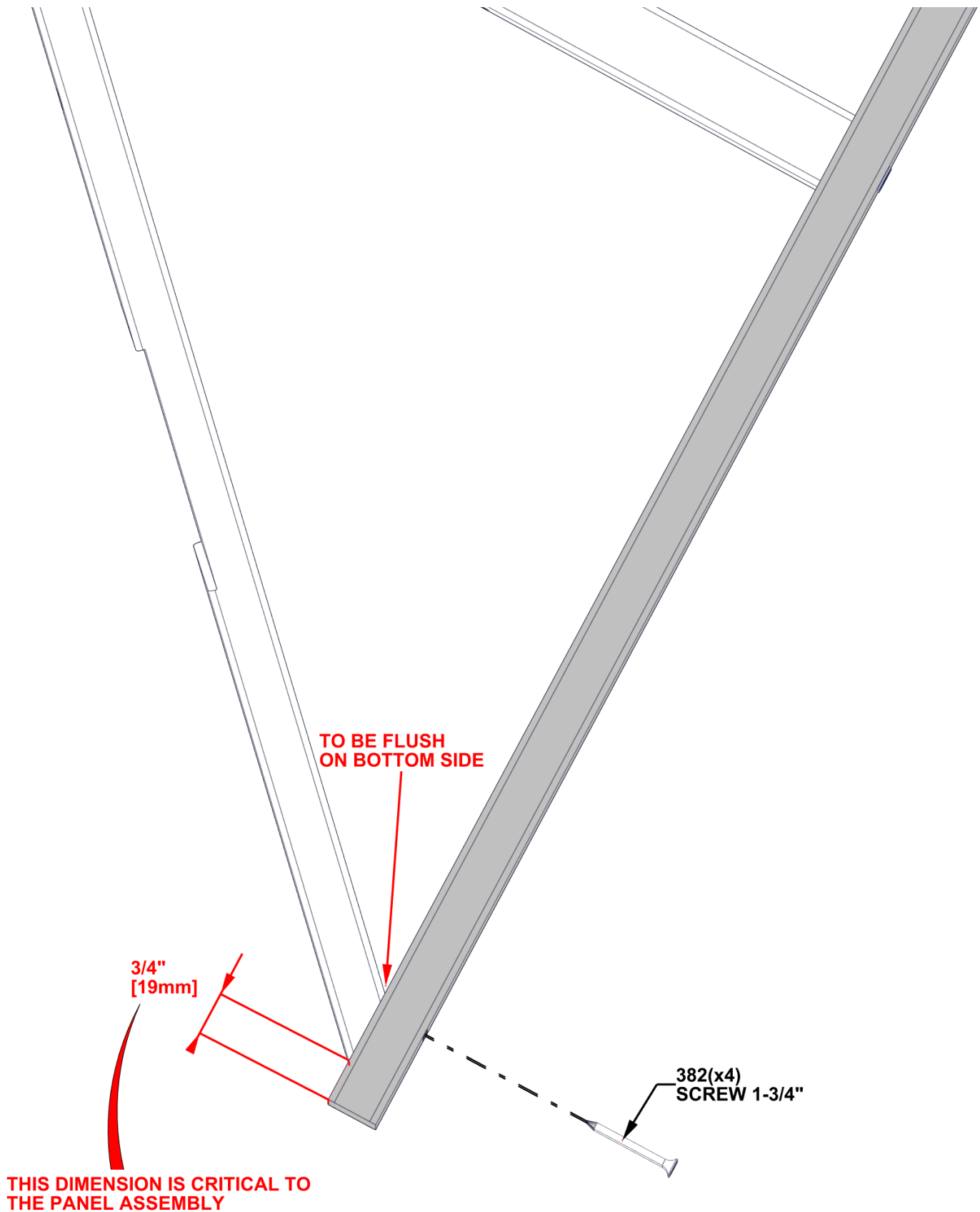

STEP 22C - 14FT ROOF PANEL ASSEMBLY

TIP:

- LOOSEN HARDWARE TO ADJUST FOR SQUARING IF NEEDED

CRITICAL:

- SQUARE UNIT BEFORE PROCEEDING TO NEXT STEPS.
- THE BELOW DIMENSIONS ARE CRITICAL TO THE FINAL ROOF ASSEMBLY.
- MEASUREMENTS SHOULD BE WITHIN +/- 1/4".
- MEASUREMENTS OUTSIDE OF TOLERANCE WILL LEAD TO THE INABILITY TO ASSEMBLE THE ROOF.

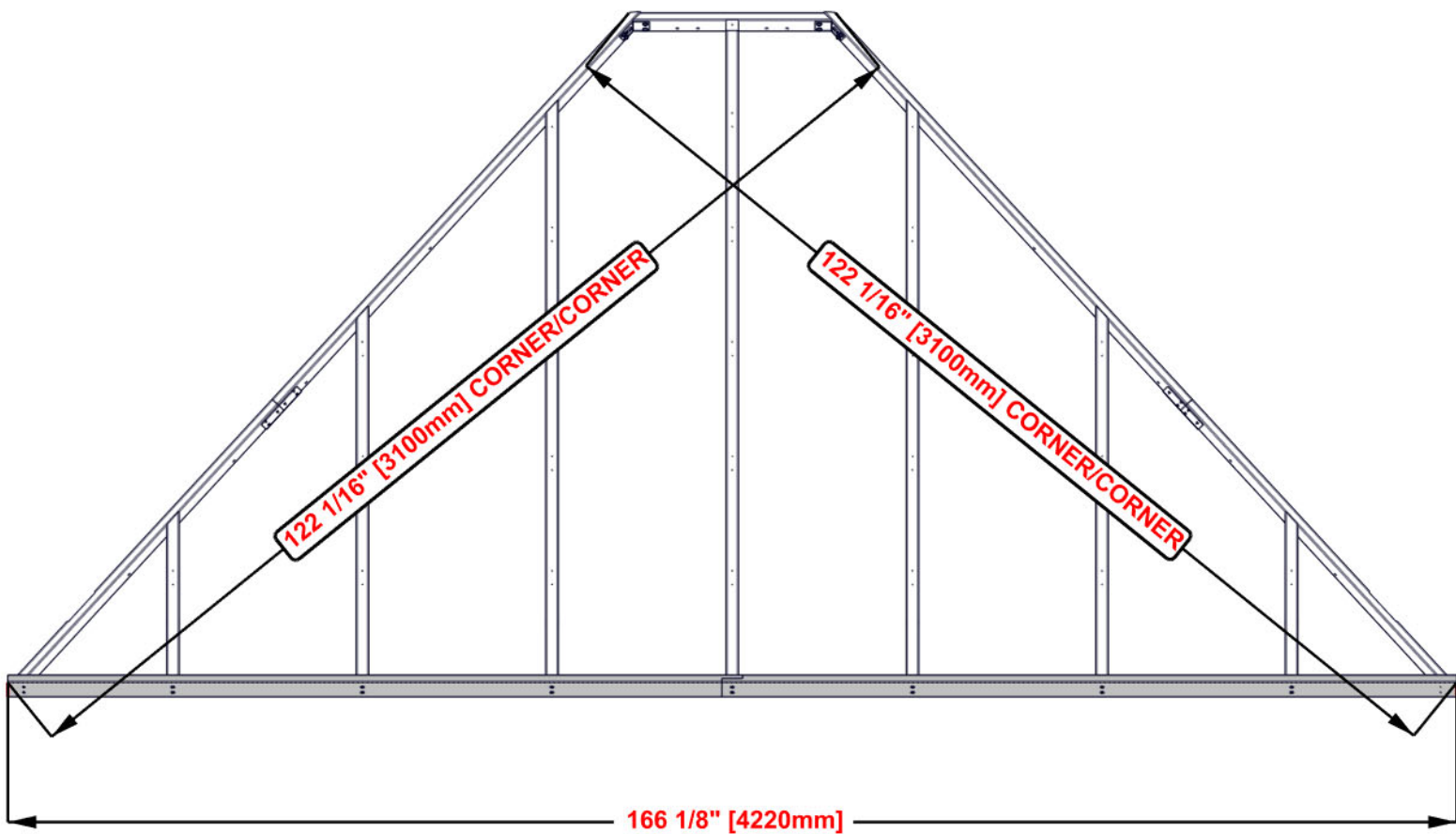

STEP 23 - 14FT ROOF PANEL ASSEMBLY

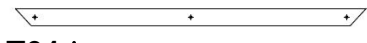

T01 | PURLIN - W4L15227
 (1) 1"x1 5/16"x27 1/2" (24x34x698)

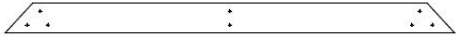

H25 | PURLIN - W4L15235
 (1) 1"x3 3/8"x51 3/16" (24x86x1299)



H14 | PURLIN - W4L15223
 (2) 1"x3 3/8"x54 9/16" (24x86x1385)

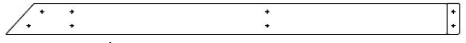

H16 | PURLIN - W4L15225
 (2) 1"x3 3/8"x51" (24x86x1295)



H13 | PURLIN - W4L15222
 (1) 1"x3 3/8"x43 11/16" (24x86x1110)

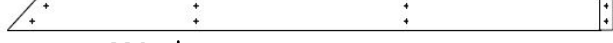

H15 | PURLIN - W4L15224
 (2) 1"x3 3/8"x63 1/8" (24x86x1603)

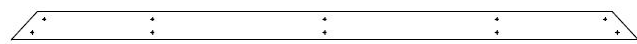

H17 | PURLIN - W4L15226
 (1) 1"x1 3/8"x75 3/8" (24x34x1915)

QTY.	PART NUMBER	DESCRIPTION
66	H100391	SCREW PFH 8x2 BLK

- TIPS:**
- ALIGN PURLIN PILOT HOLES WITH RAFTER PILOT HOLES
 - ATTACH SCREWS FROM THE CENTER AND WORK OUTWARD
 - H02/H05 AND H09/H10 BOARDS DO NOT HAVE PILOT HOLES FOR OUTSIDE EDGE SCREWS.
 - USING THE PURLINS AS A GUIDE AND A 1/8" DRILL BIT, DRILL PILOT HOLES INTO H02/H05 & H09/H10 BOARDS.

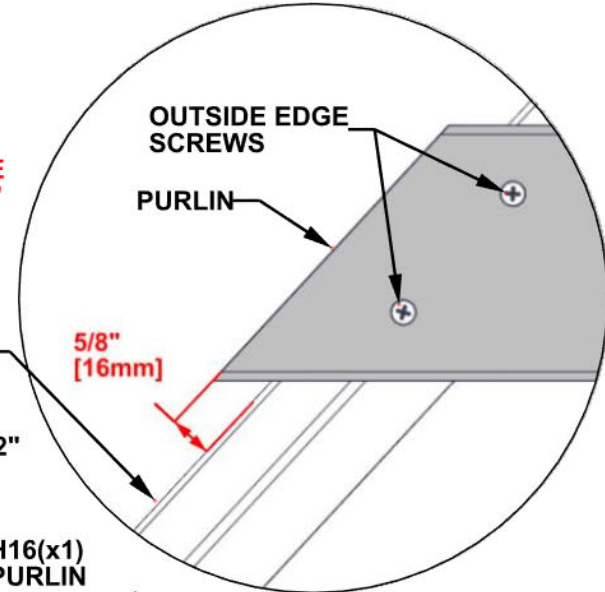

IF PURLINS OVERHANG MORE THAN 5/8", CUT DOWN TO 5/8"

T01 PURLIN WILL NOT OVERHANG

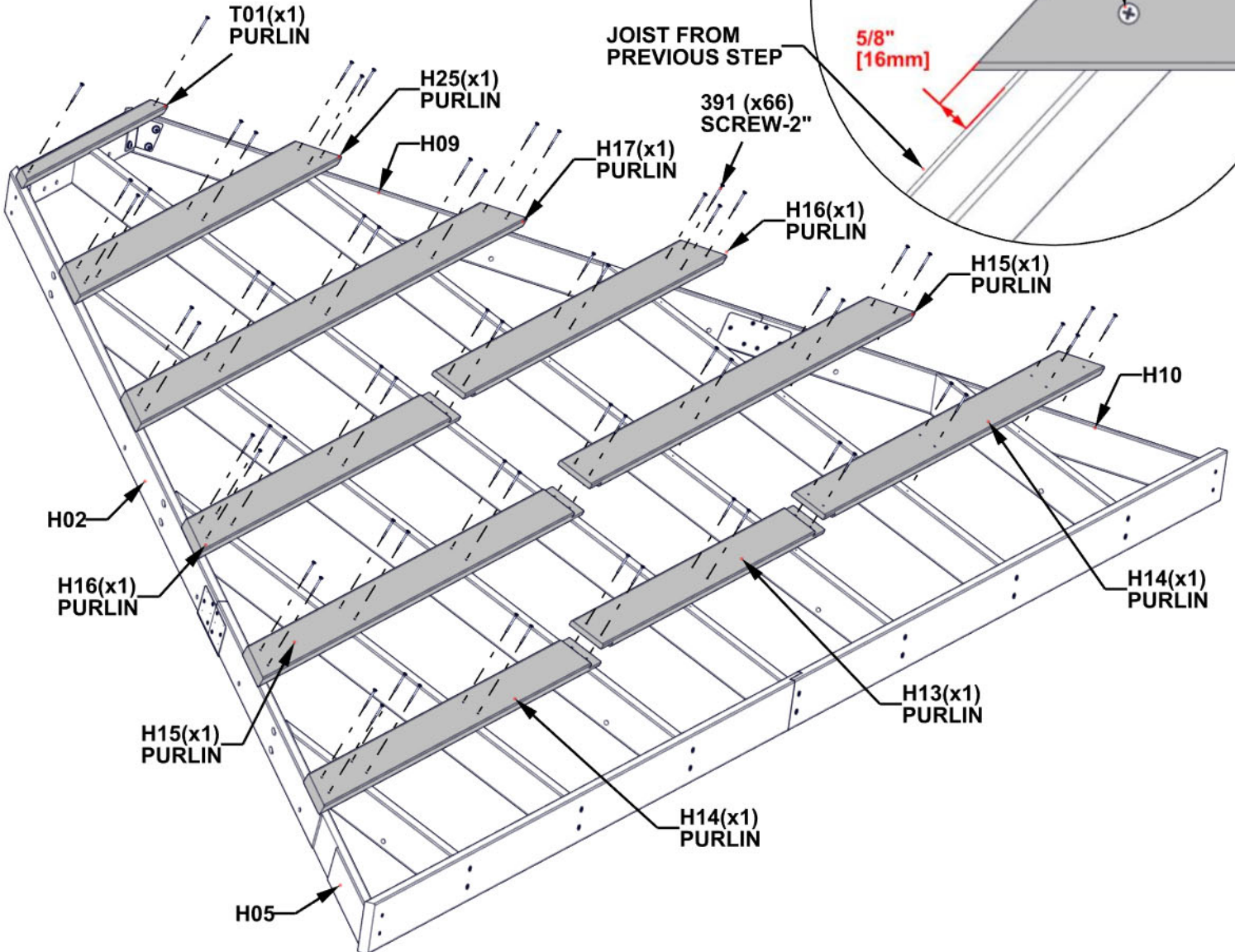

STEP 24 - 14FT ROOF PANEL ASSEMBLY

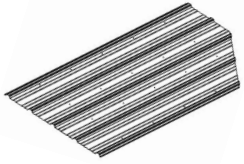

A4M02879-1 | 29 GA STEEL SHEETING
(1)

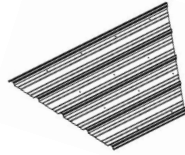

A4M02880-1 | 29 GA STEEL SHEETING
(1)

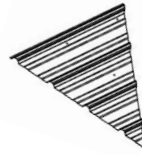

A4M02881-1 | 29 GA STEEL SHEETING
(1)

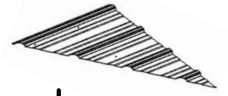

A4M02884-1 | 29 GA STEEL SHEETING
(1)

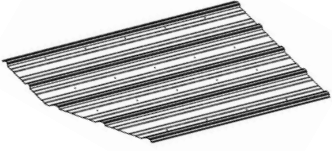

A4M02882-1 | 29 GA STEEL SHEETING
(1)

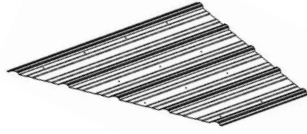

A4M02883-1 | 29 GA STEEL SHEETING
(1)

QTY.	PART NUMBER	DESCRIPTION
16	H100833	SCREW WOODGRIP 10-16x3/4"

TIPS:

- REMOVE PROTECTIVE BLUE FILM
- STARTING IN THE CENTER, PLACE PANELS AS SHOWN BELOW.
- OVERLAP PANELS BY ONE RIDGE.
- PANELS SHOULD BE FLUSH WITH PURLIN ENDS AND Q02 ROOF JOIST.
- ONCE SHEETING IS IN PLACE, IT IS RECOMMENDED TO ADD H100833 SCREWS IN THE MIDDLE OF SHEETS TO HOLD SHEETING FOR THE NEXT STEP.

WARNING: GLOVES ARE RECOMMENDED WHEN HANDLING STEEL ROOF PIECES

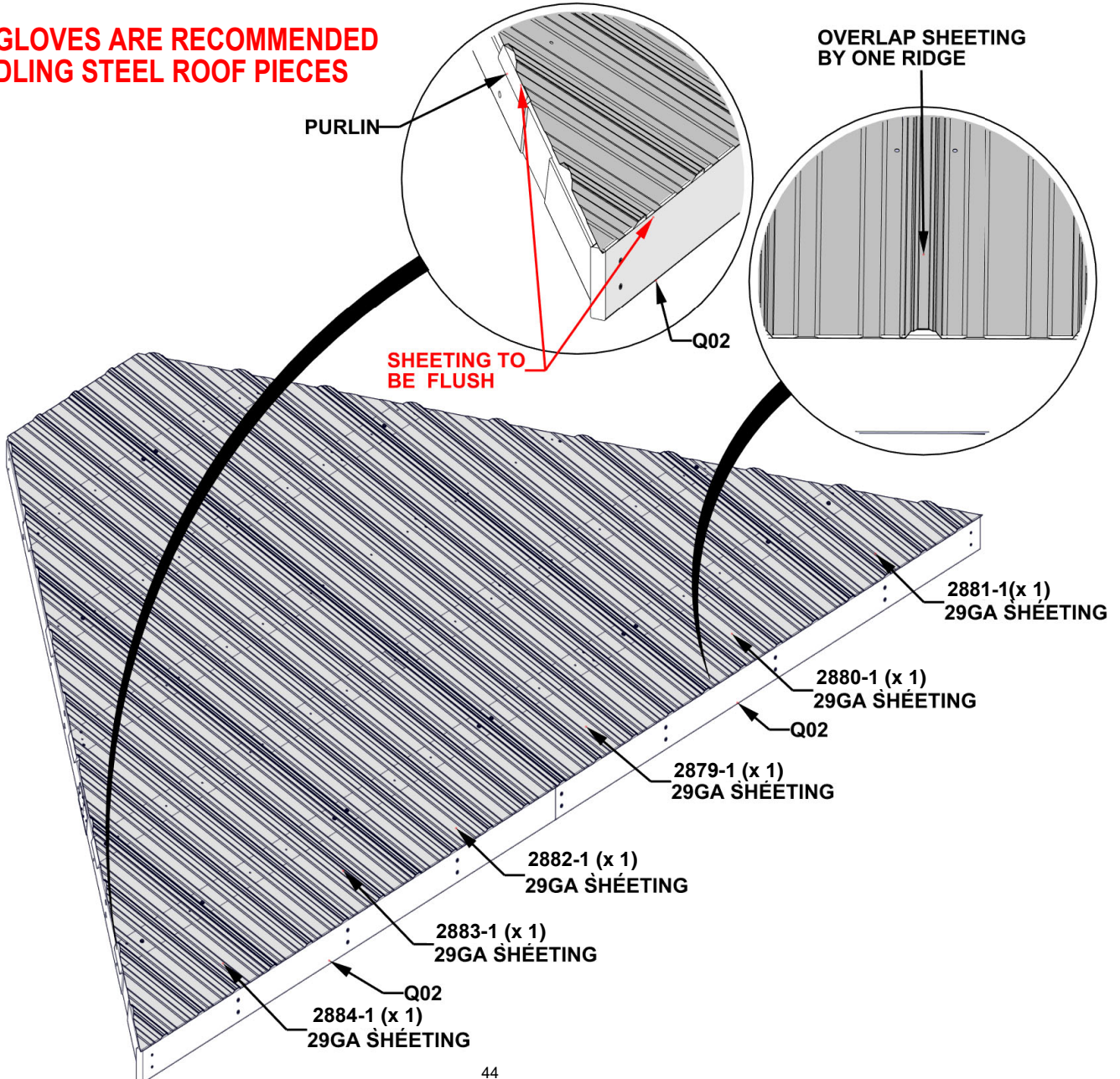

STEP 25 - 14FT ROOF PANEL ASSEMBLY

QTY.	PART NUMBER	DESCRIPTION
10	H100833	SCREW WOODGRIP 10-16x3/4"

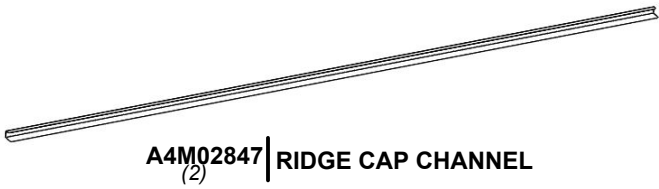

TIPS:

- POSITION THE RIDGE CAP CHANNEL OVER THE EDGE OF THE ROOF PANELS WITH THE WIDER SIDE OF THE CHANNEL ON THE BOTTOM.
- MAKE SURE THE PANELS ARE FULLY SEATED INTO THE CHANNEL.
- FLUSH THE TOP OF THE CHANNEL WITH THE TOP OF THE METAL PANELS.

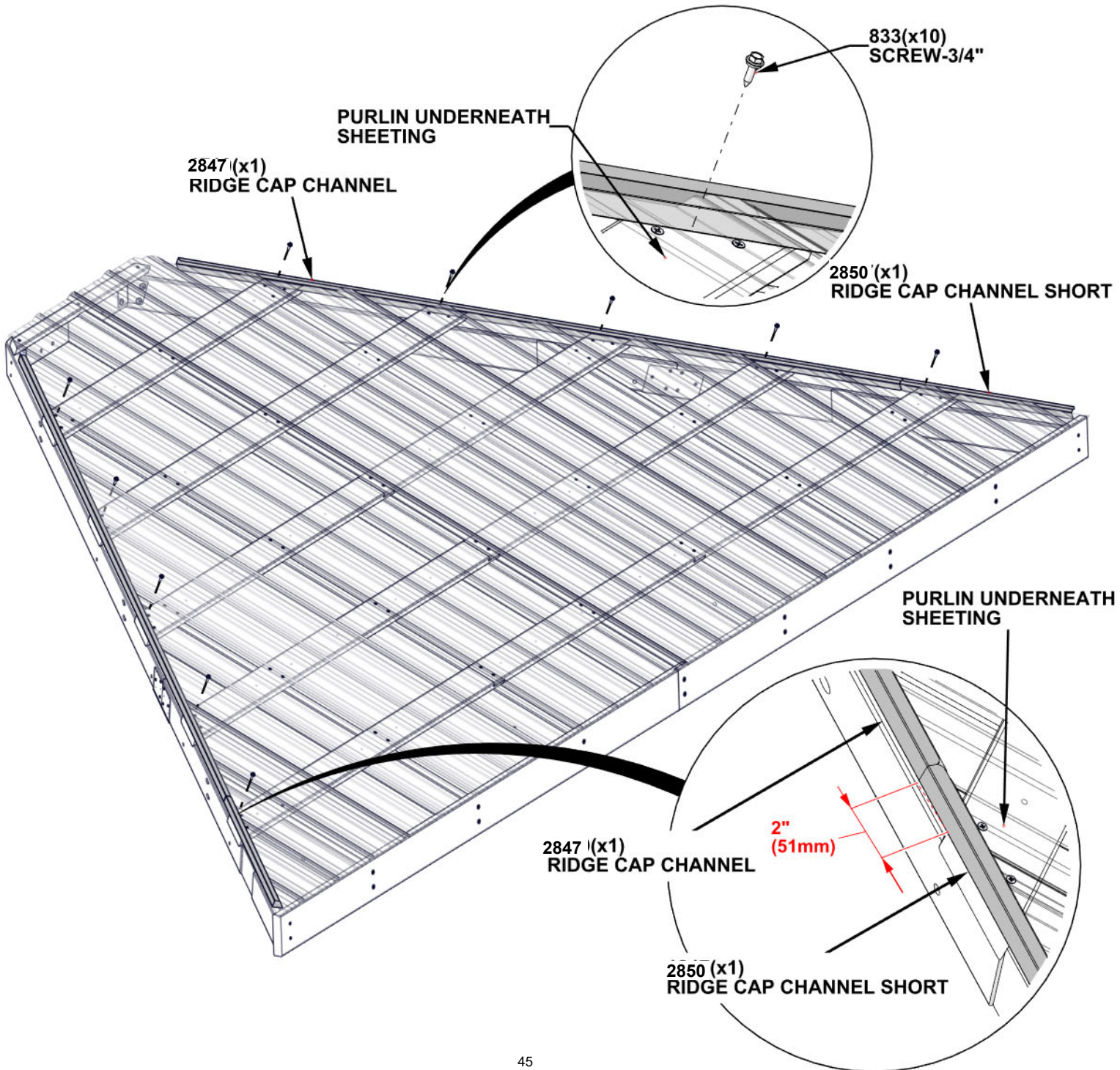

STEP 26 - 14FT ROOF PANEL ASSEMBLY

QTY.	PART NUMBER	DESCRIPTION
52	H100833	SCREW WOODGRIP 10-16x3/4"

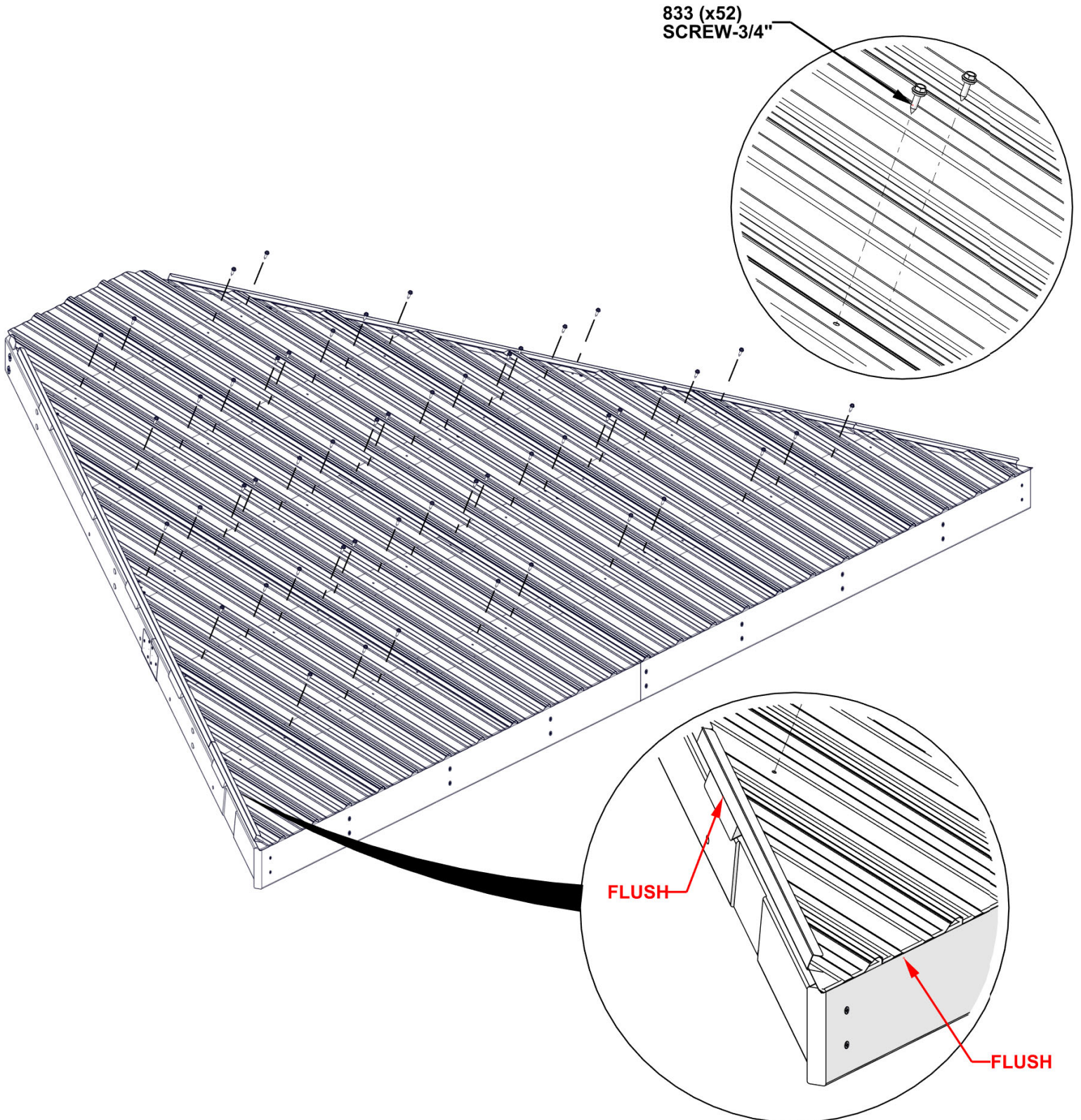

**REPEAT 14FT ROOF PANEL
ASSEMBLY STEPS 19 THROUGH 26**

STEP 27 - 12FT ROOF PANEL ASSEMBLY

QTY.	PART NUMBER	DESCRIPTION
4	H100171	BOLT WH 1/4x1 BLK
4	H100398	T-NUT 1/4 BLK

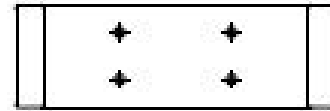
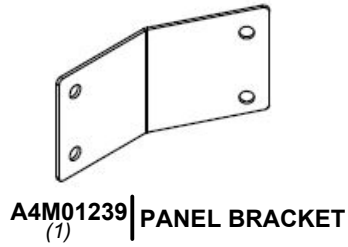
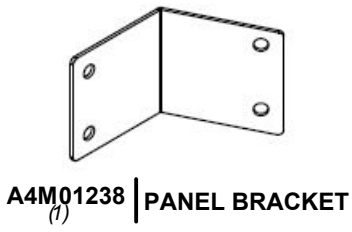

H06 | ROOF JOIST - W4L15203
(1) | 1"x3 3/8"x10 11/16" (24x86x272)

**INSERT T-NUTS FIRST
HAND TIGHTEN ONLY**

**NOTE ARROW DIRECTIONS
ON BRACKETS**

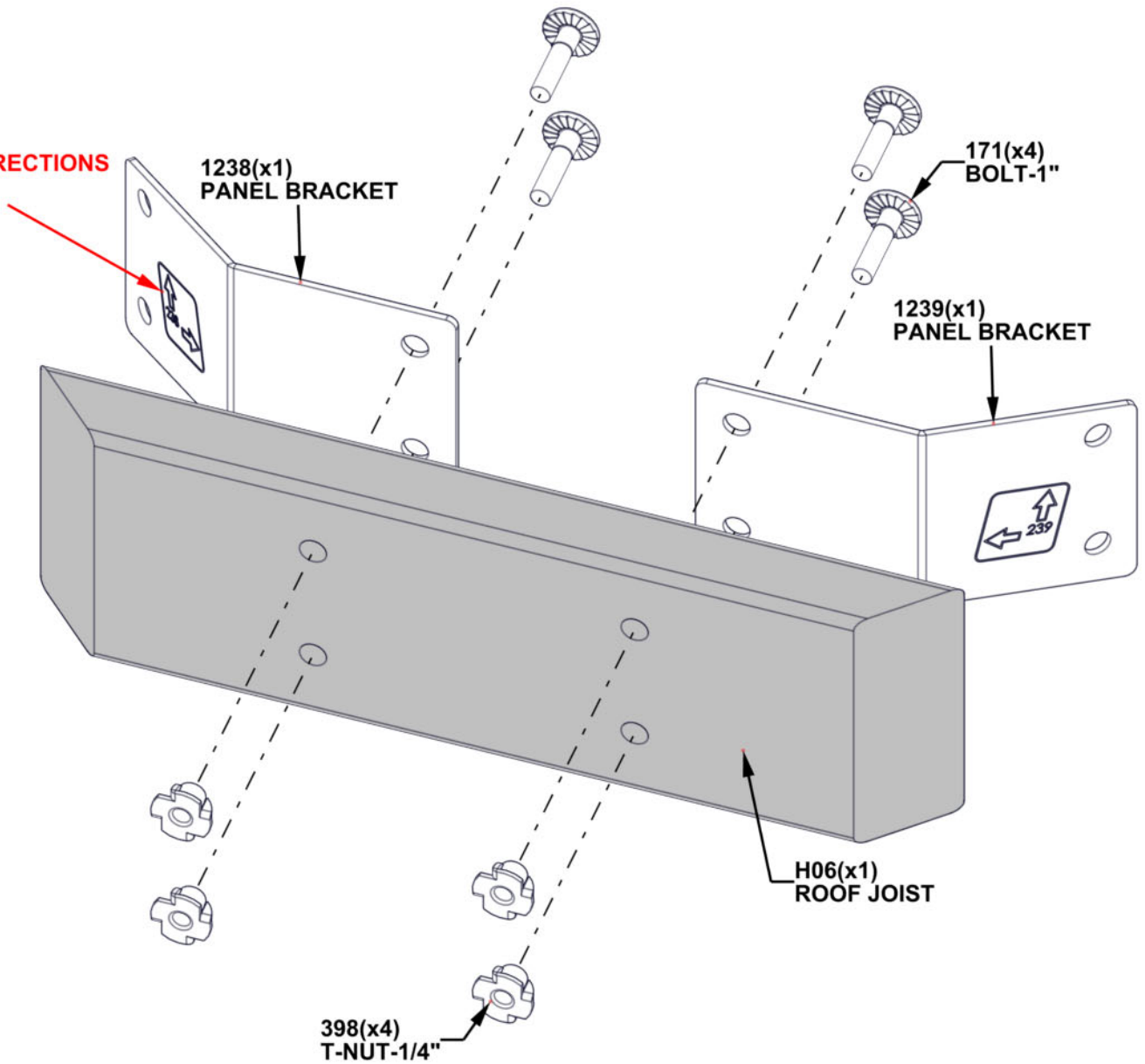

STEP 28 - 12FT ROOF PANEL ASSEMBLY



H11 | ROOF JOIST- W4L15216
 (1) | 1"x3 3/8"x44 1/2" (24x86x1130)

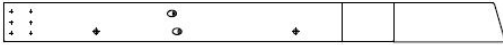

H12 | ROOF JOIST- W4L15220
 (1) | 1"x3 3/8"x44 1/2" (24x86x1130)

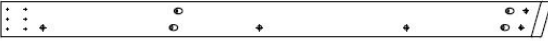

H07 | ROOF JOIST - W4L15205
 (1) | 1"x3 3/8"x53 3/16" (24x86x1351)



H08 | ROOF JOIST - W4L15206
 (1) | 1"x3 3/8"x53 3/16" (24x86x1351)

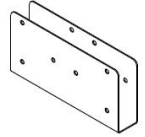

A4M01237 | ROOF SUPPORT
 (2) | SPLICE CLIP

QTY.	PART NUMBER	DESCRIPTION
4	H100171	BOLT WH 1/4x1 BLK
24	H100385	SCREW PFH 8x1 BLK
4	H100398	T-NUT 1/4 BLK

INSERT T-NUTS FIRST

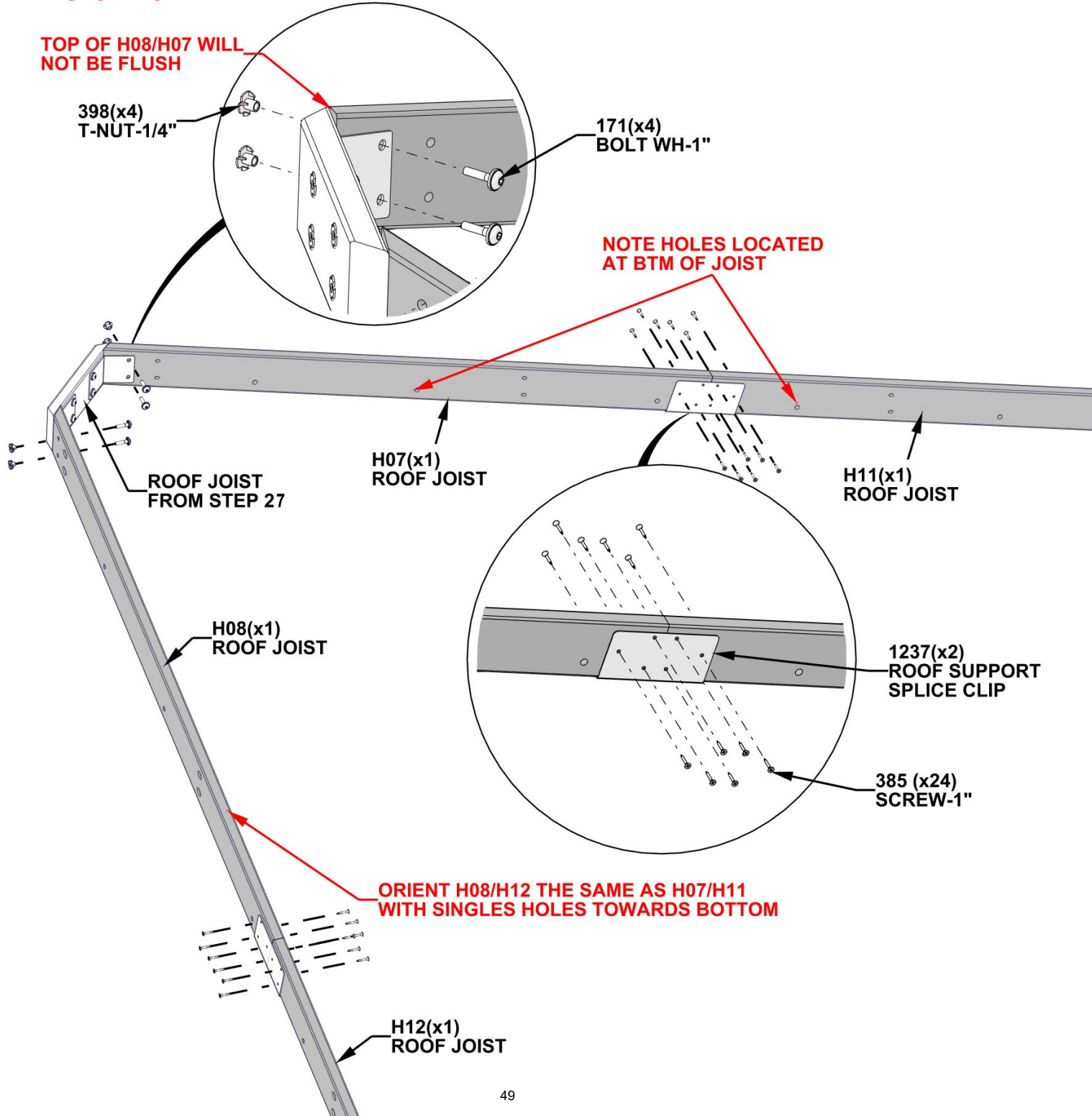

STEP 29 - 12FT ROOF PANEL ASSEMBLY

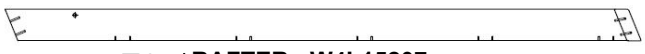

E05 | RAFTER - W4L15207
(1) | 1 3/8"x3 3/8"x69" (36x86x1752)

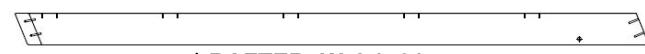

E11 | RAFTER - W4L15217
(1) | 1 3/8"x3 3/8"x69" (36x86x1752)

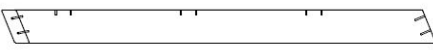

E12 | RAFTER W4L15218
(1) | 1 3/8"x3 3/8"x45 7/16" (36x86x1155)

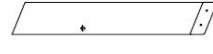

E07 | RAFTER - W4L15209
(1) | 1 3/8"x3 3/8"x21 15/16" (36x86x557)

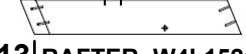

E13 | RAFTER - W4L15219
(1) | 1 3/8"x3 3/8"x21 15/16" (36x86x557)

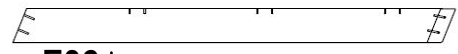

E06 | RAFTER - W4L15208
(1) | 1 3/8"x3 3/8"x45 7/16" (36x86x1155)

QTY.	PART NUMBER	DESCRIPTION
12	H101030	SCREW 2" CONFIRMAT BLK

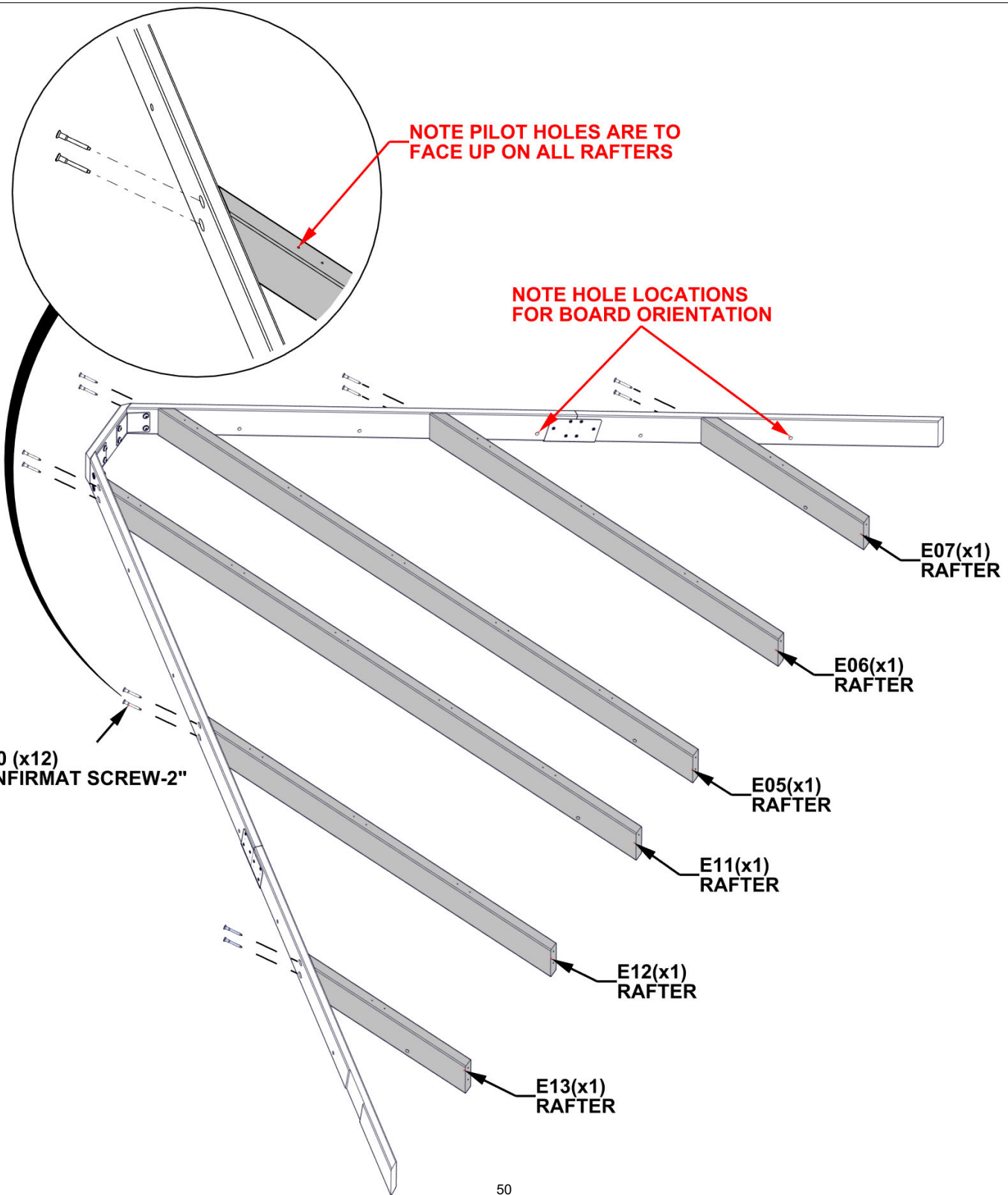

STEP 30A - 12FT ROOF PANEL ASSEMBLY

QTY.	PART NUMBER	DESCRIPTION
4	H100382	SCREW PFH 8x1 3/4 BLK
12	H101030	SCREW 2" CONRIMAT BLK



Q03 | ROOF JOIST- W4L15221
(1) | 1"x4 7/16"x80 1/2" (24x112x2044)



Q01 | ROOF JOIST- W4L15204
(1) | 1"x4 7/16"x65 15/16" (24x112x1675)

TIP:

- RAFTERS MAY NEED TO BE LOOSENED TO ATTACH Q03 AND Q01 TO H11/H12

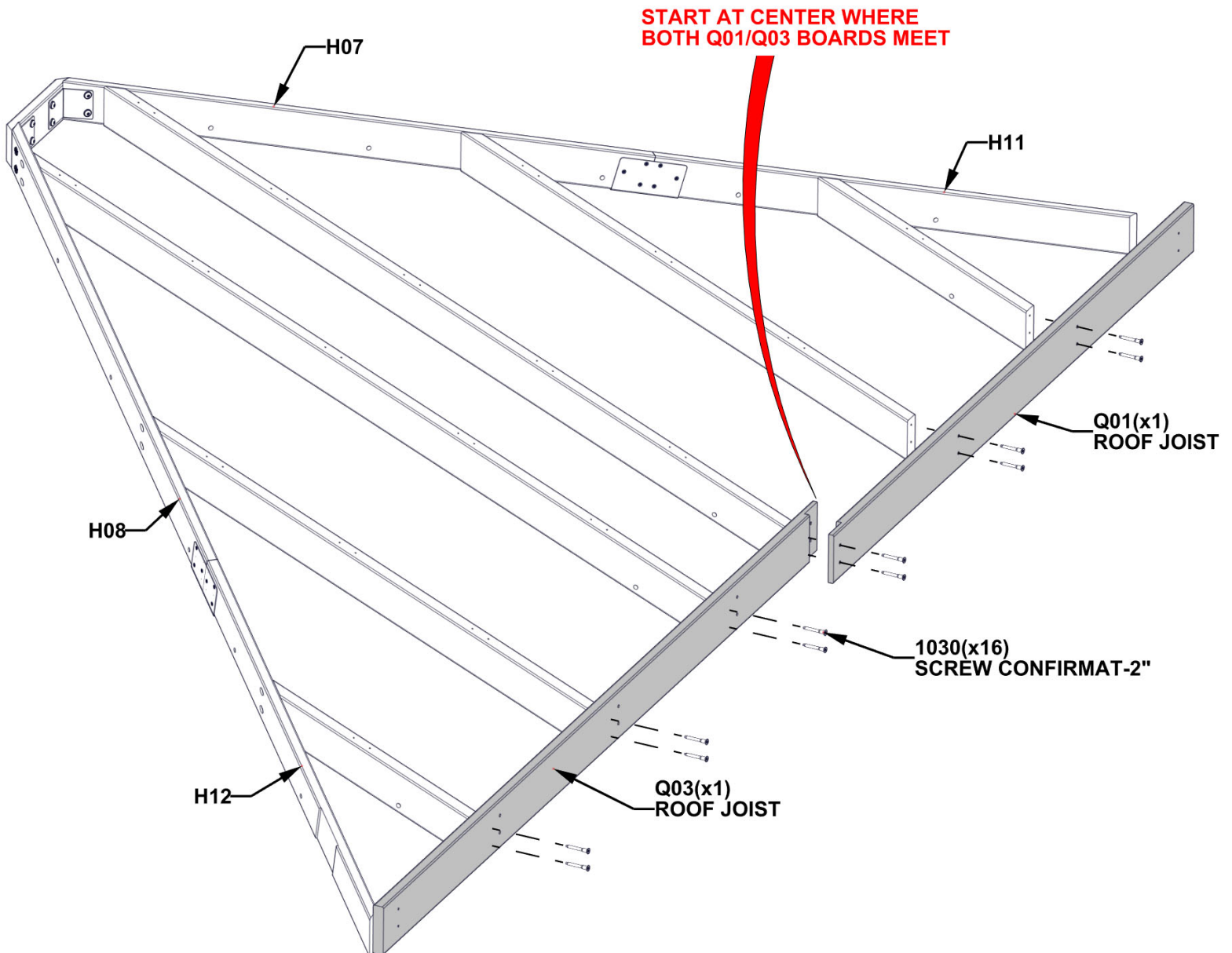

STEP 30B - 12FT ROOF PANEL ASSEMBLY

TIPS:

- USING THE Q03 BOARDS AS A GUIDE AND A 1/8" DRILL BIT, DRILL PILOT HOLES INTO THE H12 BOARD USING THE DIMENSION BELOW.
- REPEAT ON OPPOSITE END USING Q01 AS A GUIDE TO DRILL PILOT HOLES INTO THE H11 BOARD.

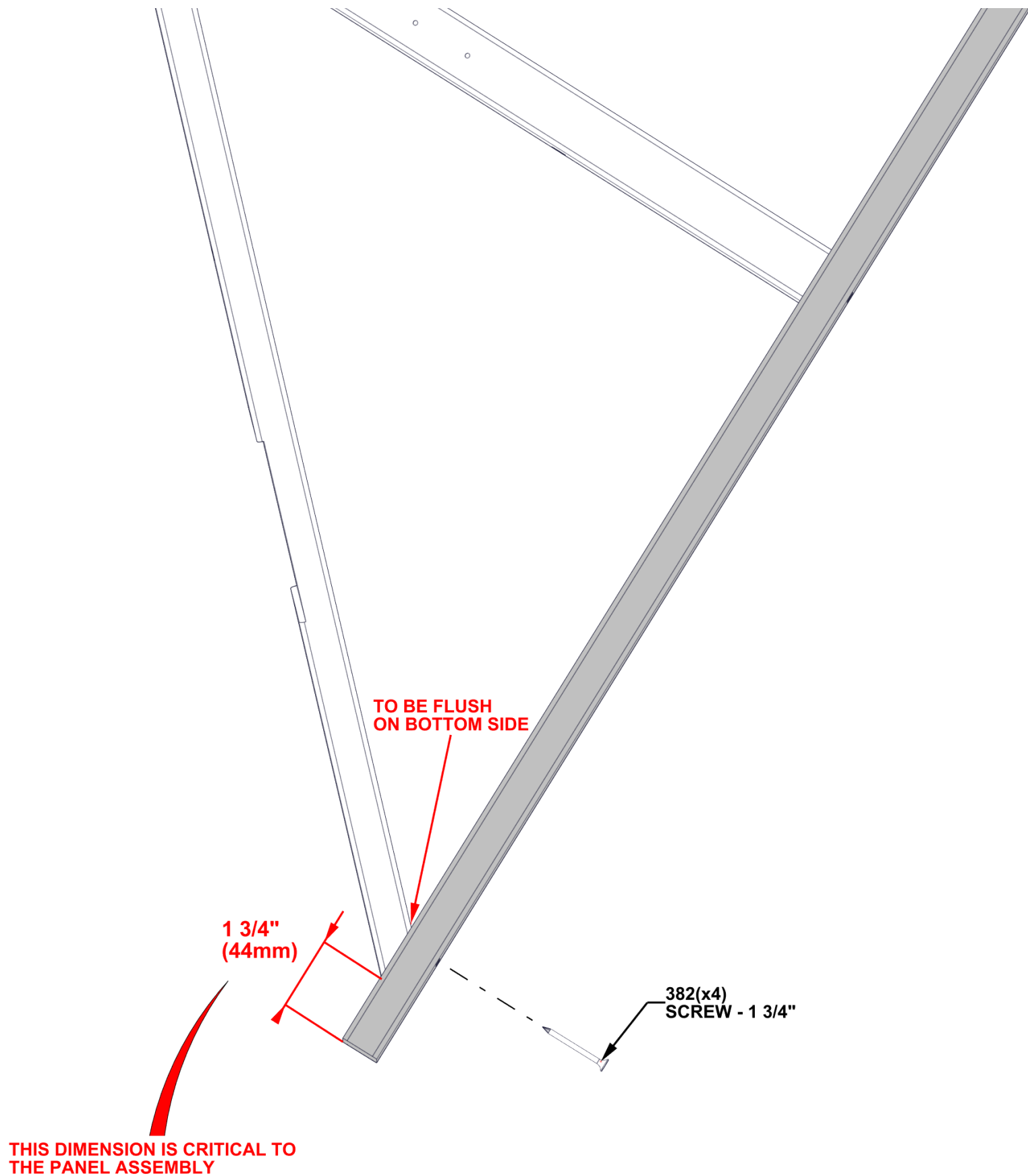

STEP 30C - 12FT ROOF PANEL ASSEMBLY

TIP:

- LOOSEN HARDWARE TO ADJUST FOR SQUARING IF NEEDED

CRITICAL:

- SQUARE UNIT BEFORE PROCEEDING TO NEXT STEPS.
- THE BELOW DIMENSIONS ARE CRITICAL TO THE FINAL ROOF ASSEMBLY.
- MEASUREMENTS SHOULD BE WITHIN +/- 1/4".
- MEASUREMENTS OUTSIDE OF TOLERANCE WILL LEAD TO THE INABILITY TO ASSEMBLE THE ROOF.

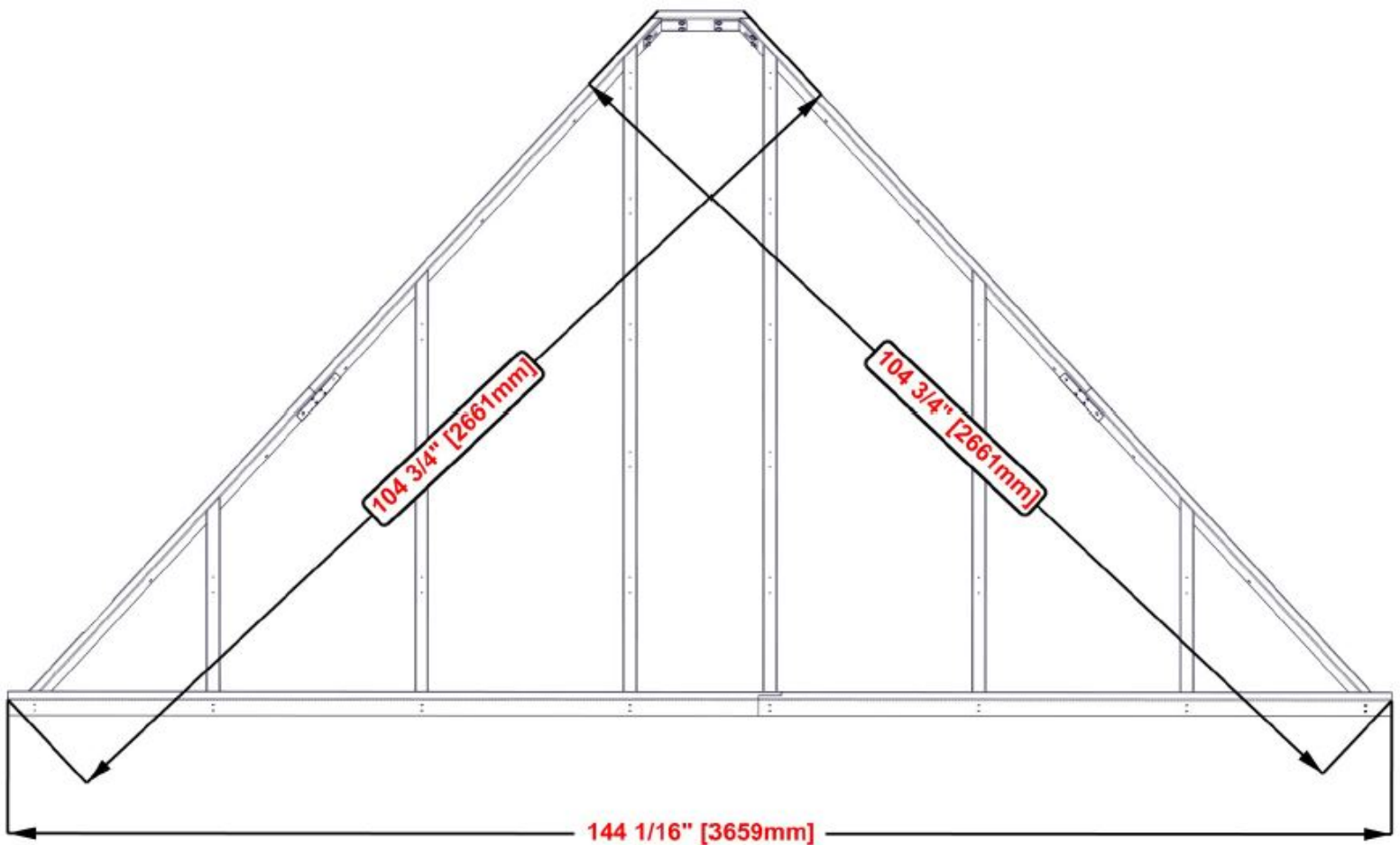

STEP 31 - 12FT ROOF PANEL ASSEMBLY

- T02** | PURLIN- W4L15239
(1) | 1"x1 5/16"x12 3/4" (24x34x324)
- H24** | PURLIN W4L15232
(1) | 1"x3 3/8"x27 1/4" (24x86x692)

QTY.	PART NUMBER	DESCRIPTION
58	H100391	SCREW PFH 8x2 BLK

- H22** | PURLIN- W4L15231
(1) | 1"x3 3/8"x51 7/16" (24x86x1307)
- H19** | PURLIN- W4L15228
(1) | 1"x3 3/8"x58 5/16" (24x86x1481)
- H20** | PURLIN- W4L15229
(1) | 1"x3 3/8"x43 7/8" (24x86x1114)
- H21** | PURLIN- W4L15230
(1) | 1"x3 3/8"x75 11/16" (24x86x1922)
- H28** | PURLIN- W4L15238
(1) | 1"x3 3/8"x70 1/2" (24x86x1791)
- H27** | PURLIN- W4L15237
(1) | 1"x3 3/8"x56" (24x86x1422)

TIPS:

- ALIGN PURLIN PILOT HOLES WITH RAFTER PILOT HOLES
- ATTACH SCREWS FROM THE CENTER AND WORK OUTWARD
- **H08/H12** AND **H07/H11** DO NOT HAVE PILOT HOLES FOR OUTSIDE EDGE SCREWS.
- USING THE PURLINS AS A GUIDE AND A 1/8" DRILL BIT, DRILL PILOT HOLES INTO **H08/H12** AND **H07/H11** BOARDS.

IF PURLINS OVERHANG MORE THAN 5/8", CUT DOWN TO 5/8"

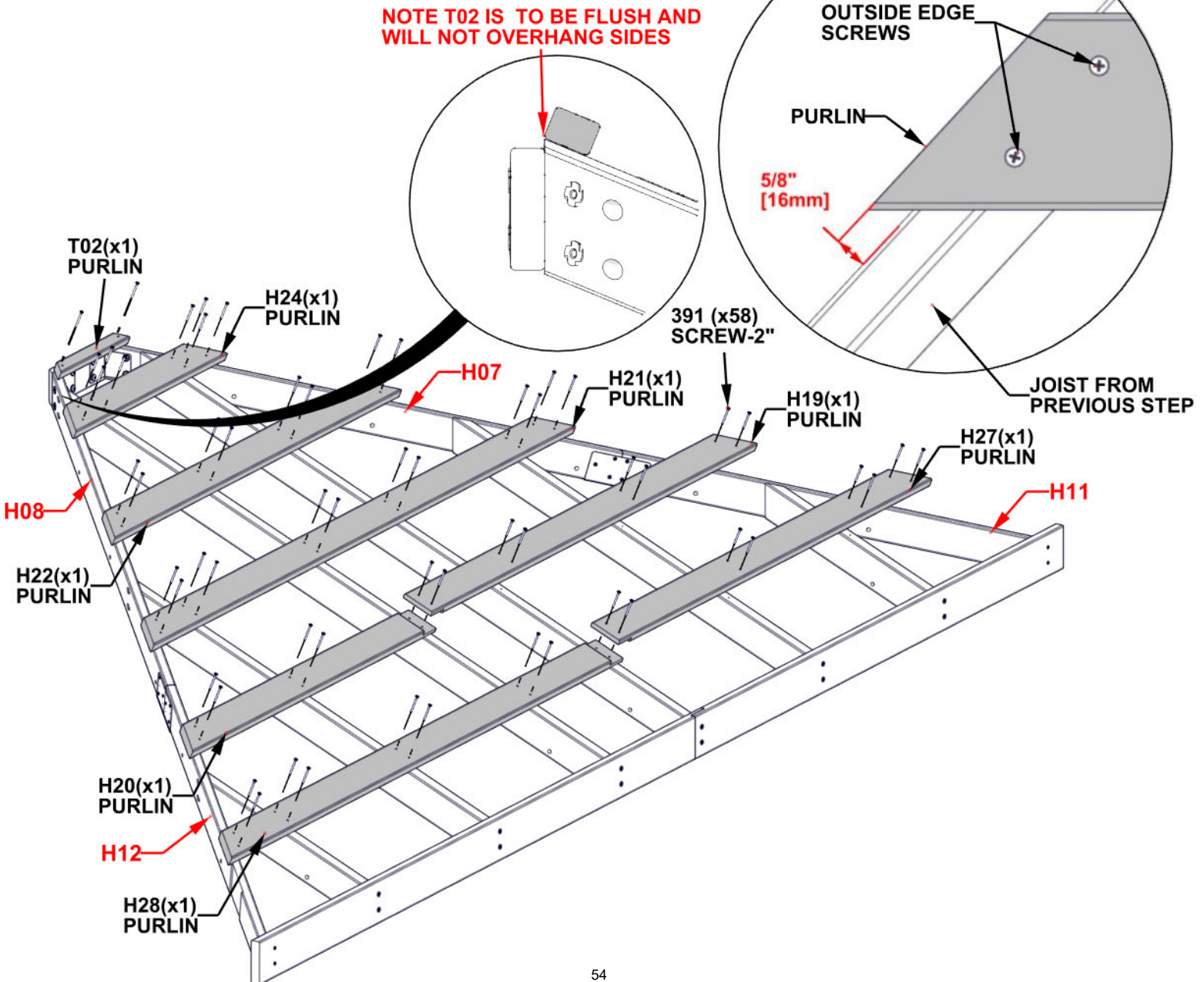

STEP 32 - 12FT ROOF PANEL ASSEMBLY

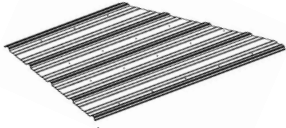

A4M02884-2
(1) | 29 GA STEEL SHEETING



A4M02883-2
(1) | 29 GA STEEL SHEETING



A4M02879-2
(1) | 29 GA STEEL SHEETING



A4M02882-2
(1) | 29 GA STEEL SHEETING

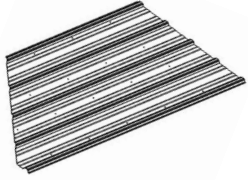

A4M02881-2
(1) | 29 GA STEEL SHEETING

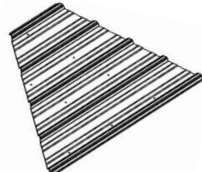

A4M02880-2
(1) | 29 GA STEEL SHEETING

QTY.	PART NUMBER	DESCRIPTION
14	H100833	SCREW WOODGRIP 10-16x3/4"

TIPS:

- REMOVE PROTECTIVE BLUE FILM
- STARTING IN THE CENTER, PLACE PANELS AS SHOWN BELOW.
- OVERLAP PANELS BY ONE RIDGE.
- PANELS SHOULD BE FLUSH WITH PURLIN ENDS AND Q01 ROOF JOIST.
- ONCE SHEETING IS IN PLACE, IT IS RECOMMENDED TO ADD H100833 SCREWS IN THE MIDDLE OF SHEETS TO HOLD SHEETING FOR THE NEXT STEP.

WARNING: GLOVES ARE RECOMMENDED WHEN HANDLING STEEL ROOF PIECES

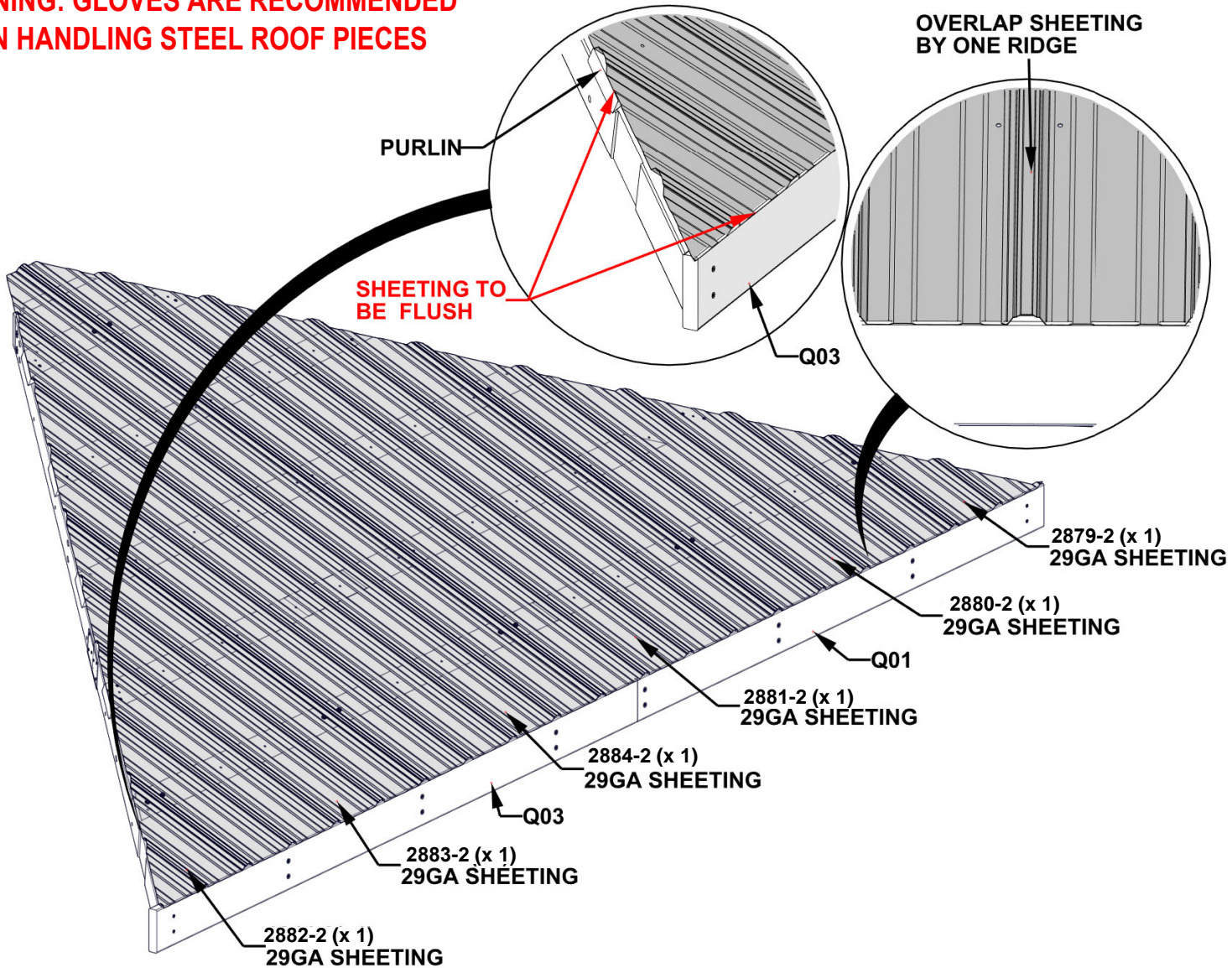

STEP 33 - 12FT ROOF PANEL ASSEMBLY

QTY.	PART NUMBER	DESCRIPTION
8	H100833	SCREW WOODGRIP 10-16x3/4"

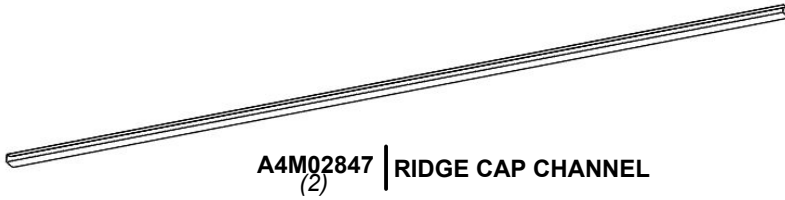

TIPS:

- POSITION THE RIDGE CAP CHANNEL OVER THE EDGE OF THE ROOF PANELS WITH THE WIDER SIDE OF THE CHANNEL ON THE BOTTOM.
- MAKE SURE THE PANELS ARE FULLY SEATED INTO THE CHANNEL.
- FLUSH THE TOP OF THE CHANNEL WITH THE TOP OF THE METAL PANELS.

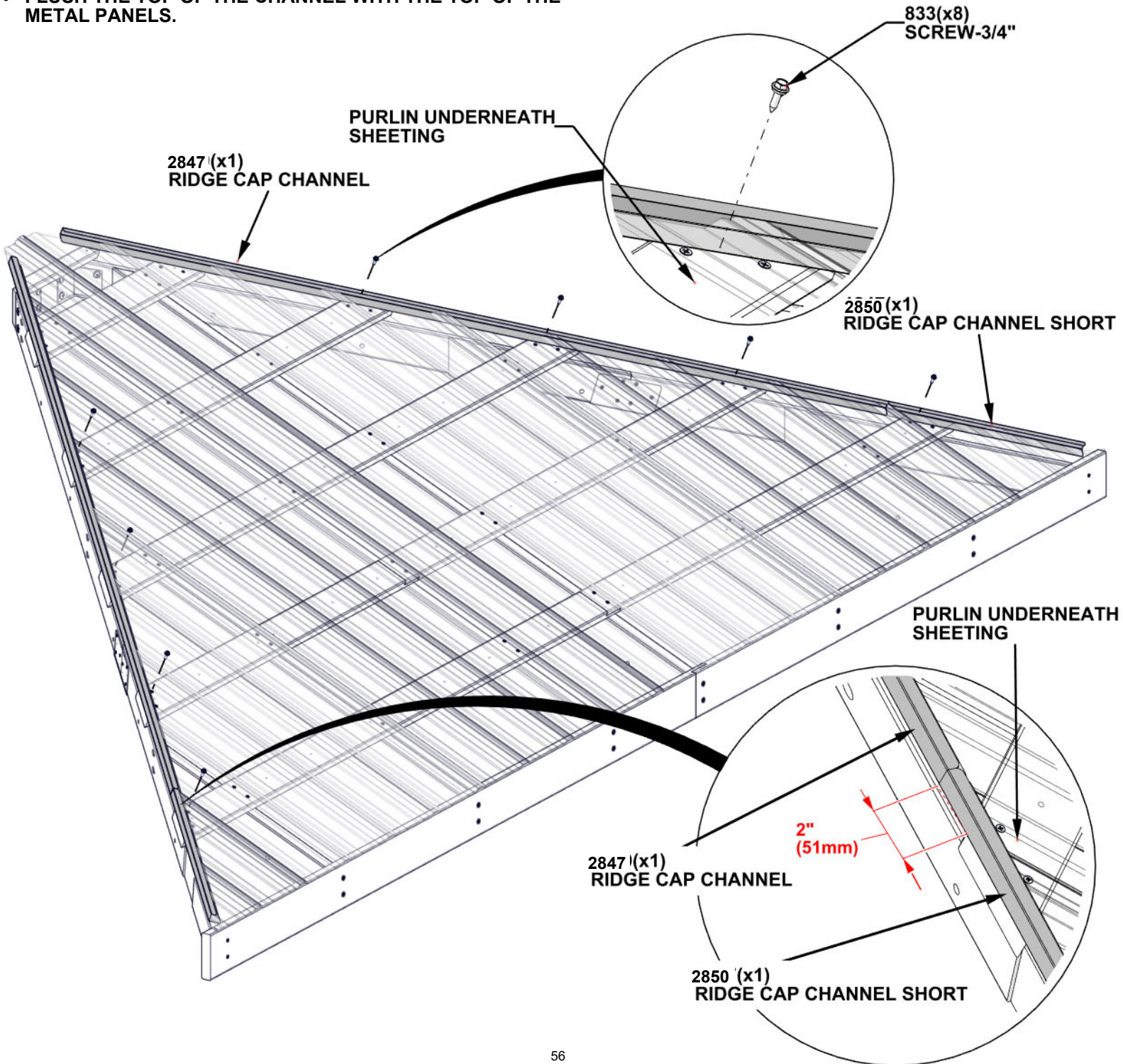

STEP 34 - 12FT ROOF PANEL ASSEMBLY

QTY.	PART NUMBER	DESCRIPTION
38	H100833	SCREW WOODGRIP 10-16x3/4"

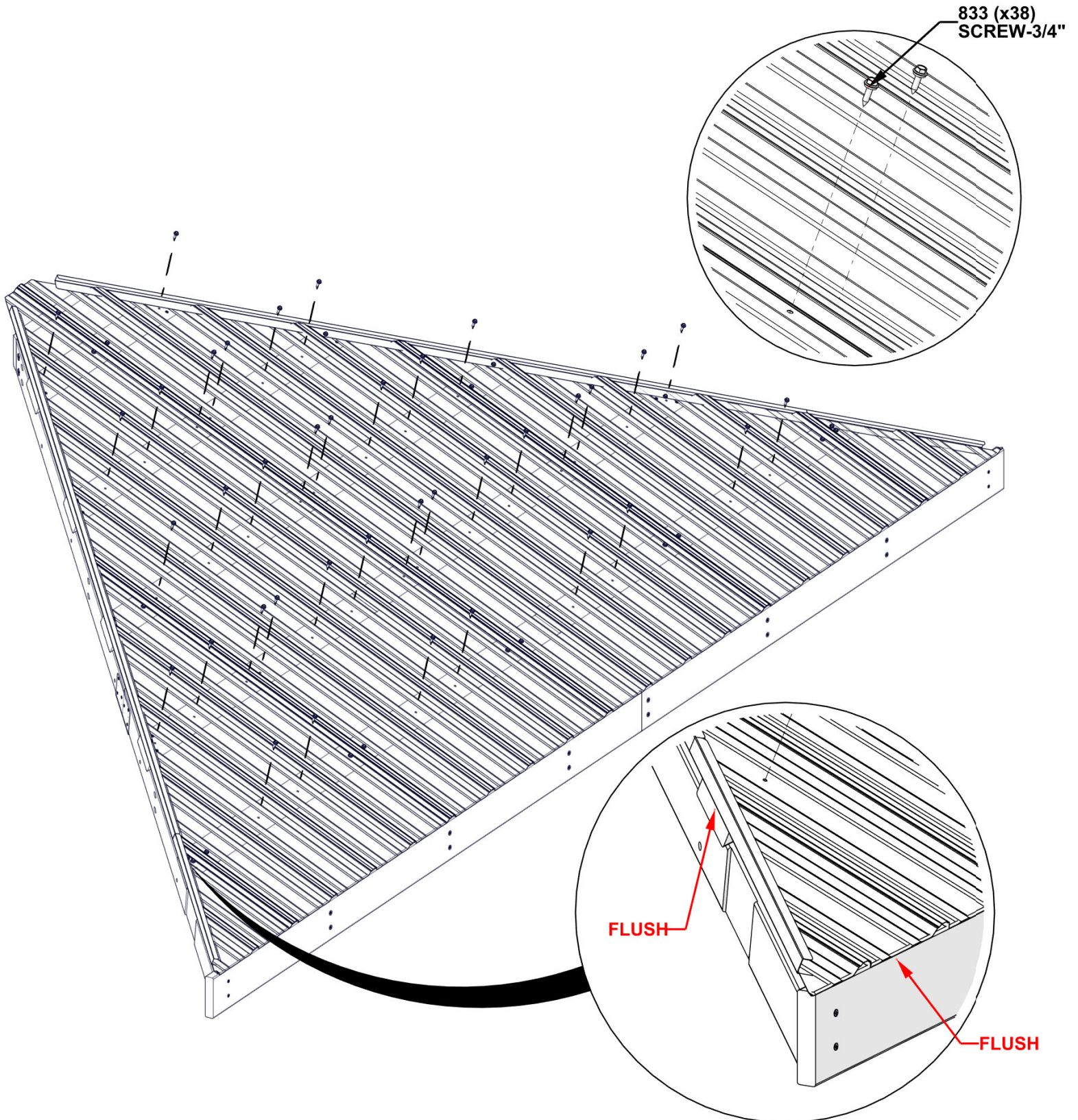

**REPEAT 12FT ROOF PANEL
ASSEMBLY STEPS 27 THROUGH 34**

STEP 35A - 12FT ROOF PANEL ATTACHMENT

TIPS:

- THREE PEOPLE ARE HELPFUL FOR THIS STEP.
- POSITION A PERSON ON A LADDER IN THE CENTER OF THE GAZEBO TO HELP SUPPORT THE ROOF PANEL.
- WITH TWO PEOPLE, WORK THE PANEL UP WITHOUT SLIDING OR DRAGGING, UNTIL IT MEETS THE ROOF SUPPORT FRAME.
- MAKE SURE THE ROOF PANEL SLIDES UNDERNEATH THE RIDGE CAP.

WARNING: GLOVES ARE RECOMMENDED WHEN HANDLING STEEL ROOF PIECES

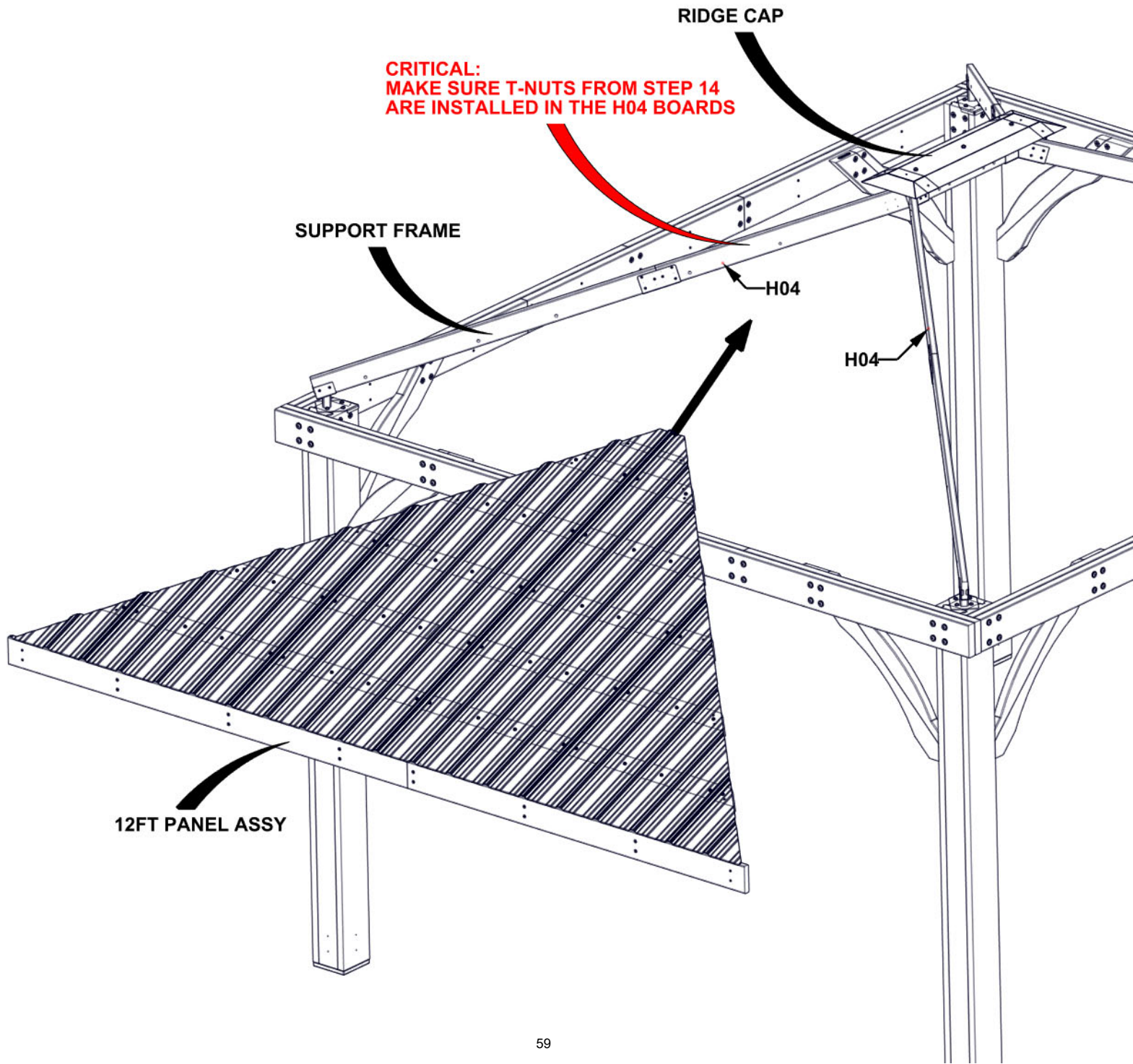

STEP 35B - 12FT ROOF PANEL ATTACHMENT

QTY	PART NUMBER	DESCRIPTION
2	H100198	WASHER LOCK EXT 8X19 BLK
2	H100378	BOLT WH 5/16x1 3/4 BLK

- TIPS:
- IF NECESSARY, USE A LONG SCREWDRIVER OR CLAMPS TO HOLD PANELS IN PLACE.
 - INSERT BOLTS INTO THE FIRST HOLE FROM THE TOP OF THE H07 & H08 BOARDS.

HAND TIGHTEN ONLY

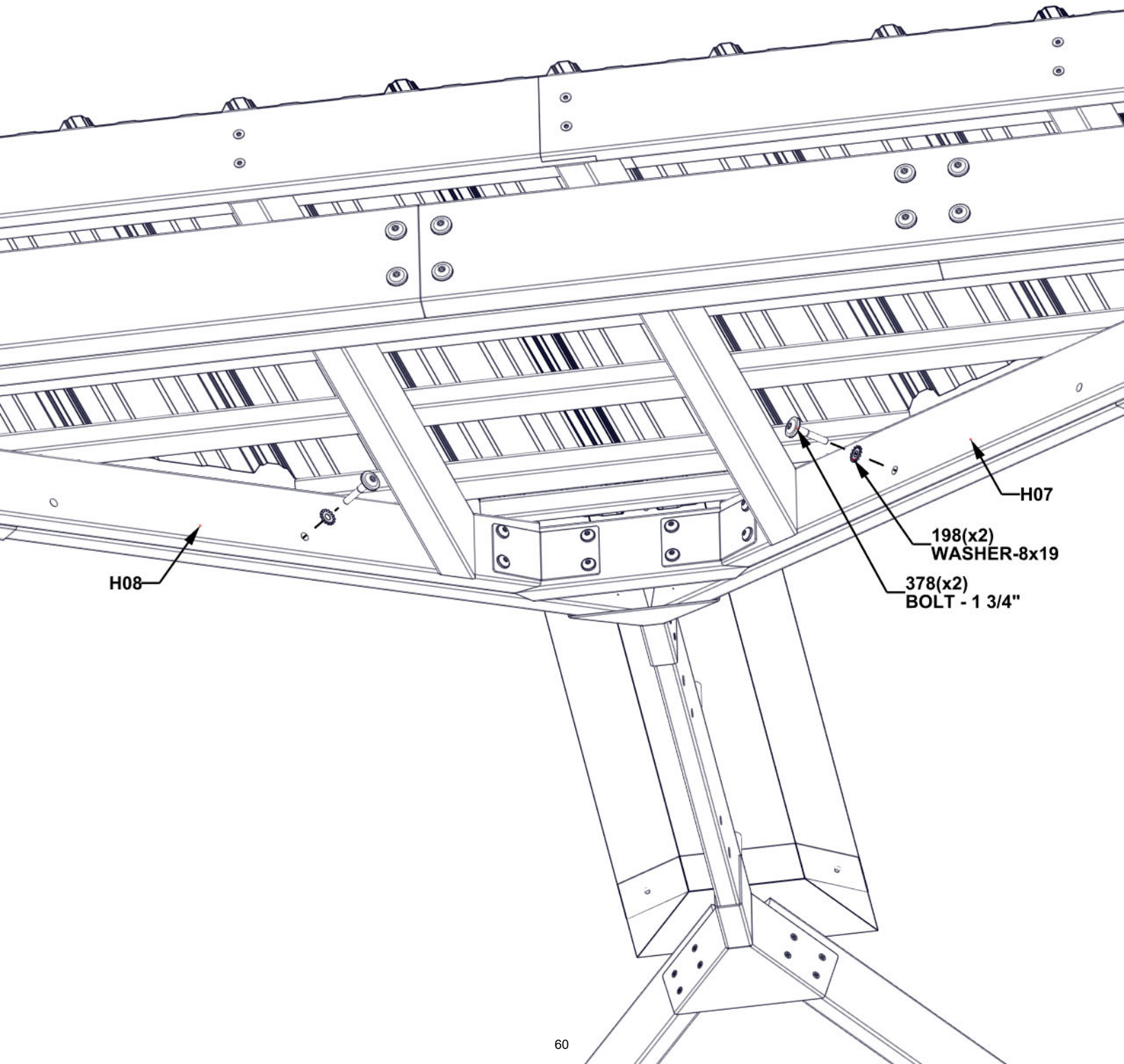

**REPEAT 12FT ROOF PANEL INSTALLATION
STEPS 35A & 35B**

STEP 36A - 14FT ROOF PANEL ATTACHMENT

TIPS:

- THREE PEOPLE ARE HELPFUL FOR THIS STEP.
- POSITION A PERSON ON A LADDER IN THE CENTER OF THE GAZEBO TO HELP SUPPORT THE ROOF PANEL.
- WITH TWO PEOPLE, WORK THE PANEL UP, WITHOUT SLIDING OR DRAGGING, UNTIL IT MEETS THE ROOF SUPPORT FRAME.
- MAKE SURE THE ROOF PANEL SLIDES UNDERNEATH THE RIDGE CAP.

WARNING: GLOVES ARE RECOMMENDED WHEN HANDLING STEEL ROOF PIECES

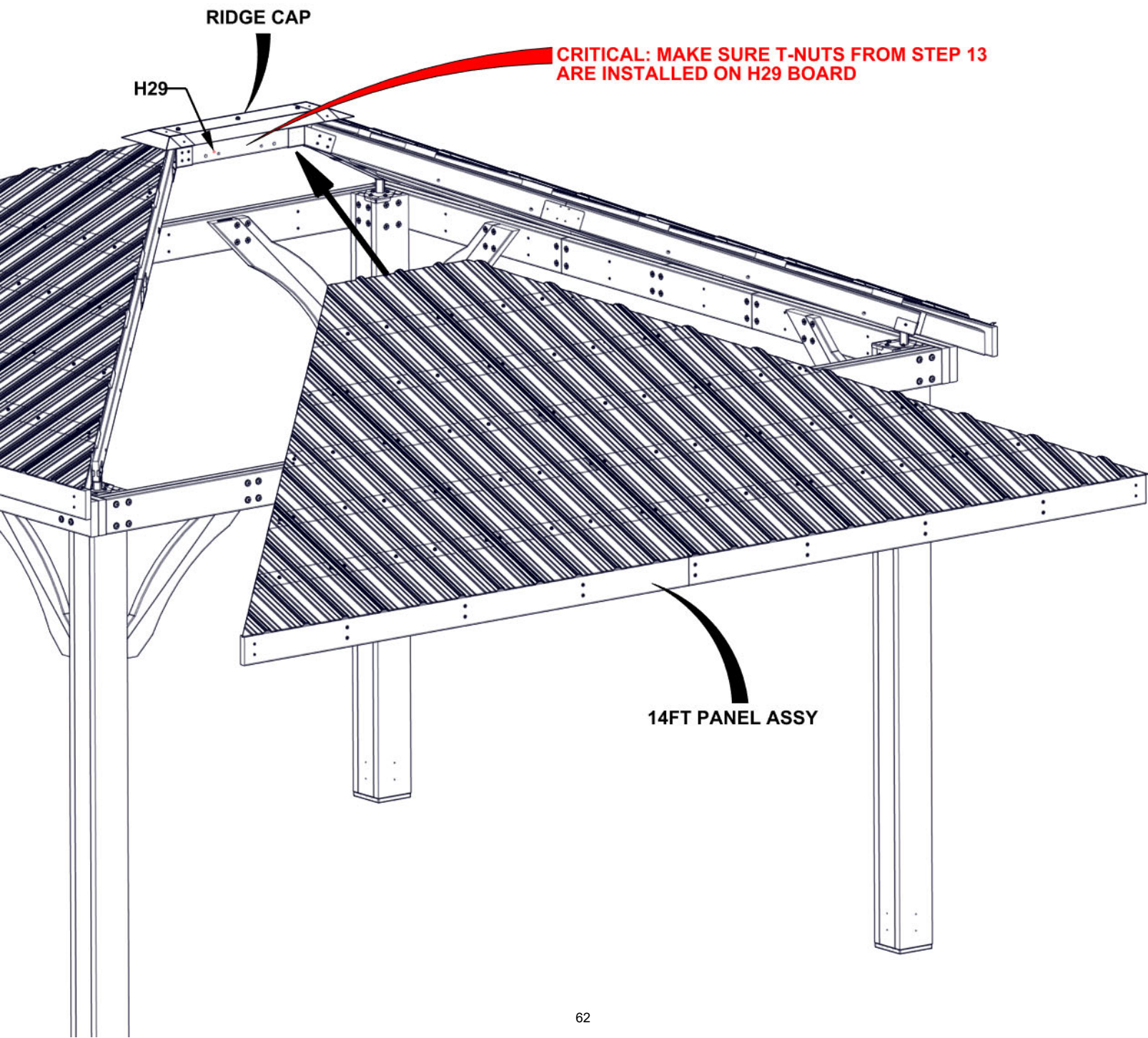

STEP 36B - 14FT ROOF PANEL ATTACHMENT

QTY	PART NUMBER	DESCRIPTION
2	H100378	BOLT WH 5/16x1 3/4 BLK
2	H100198	WASHER LOCK EXT 8X19 BLK

- TIPS:**
- IF NECESSARY, USE A LONG SCREWDRIVER OR CLAMPS TO HOLD PANELS IN PLACE.

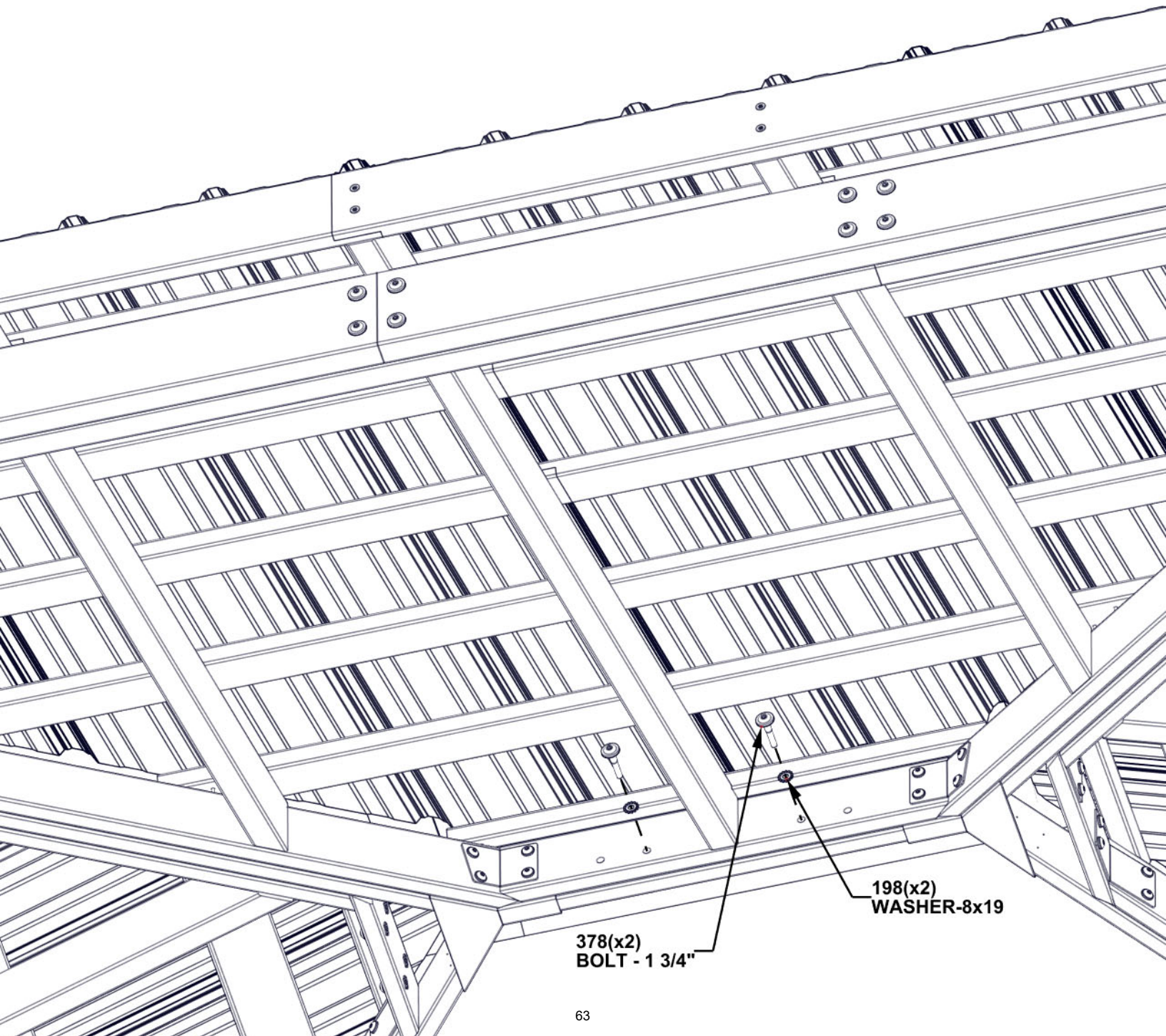

STEP 37A - 14FT ROOF PANEL ATTACHMENT

QTY	PART NUMBER	DESCRIPTION
2	H100198	WASHER LOCK EXT 8X19 BLK
2	H100415	BOLT WH 5/16X3 3/4 BLK
2	H100479	NUT LOCK 5/16 BLK
2	H100770	WASHER FLAT 5/16 BLK

TIPS:

- REPEAT STEPS 36A FOR SECOND 14FT ROOF PANEL.
- IF NECESSARY USE A LONG SCREWDRIVER OR CLAMPS TO HOLD PANEL IN PLACE.

HAND TIGHTEN ONLY

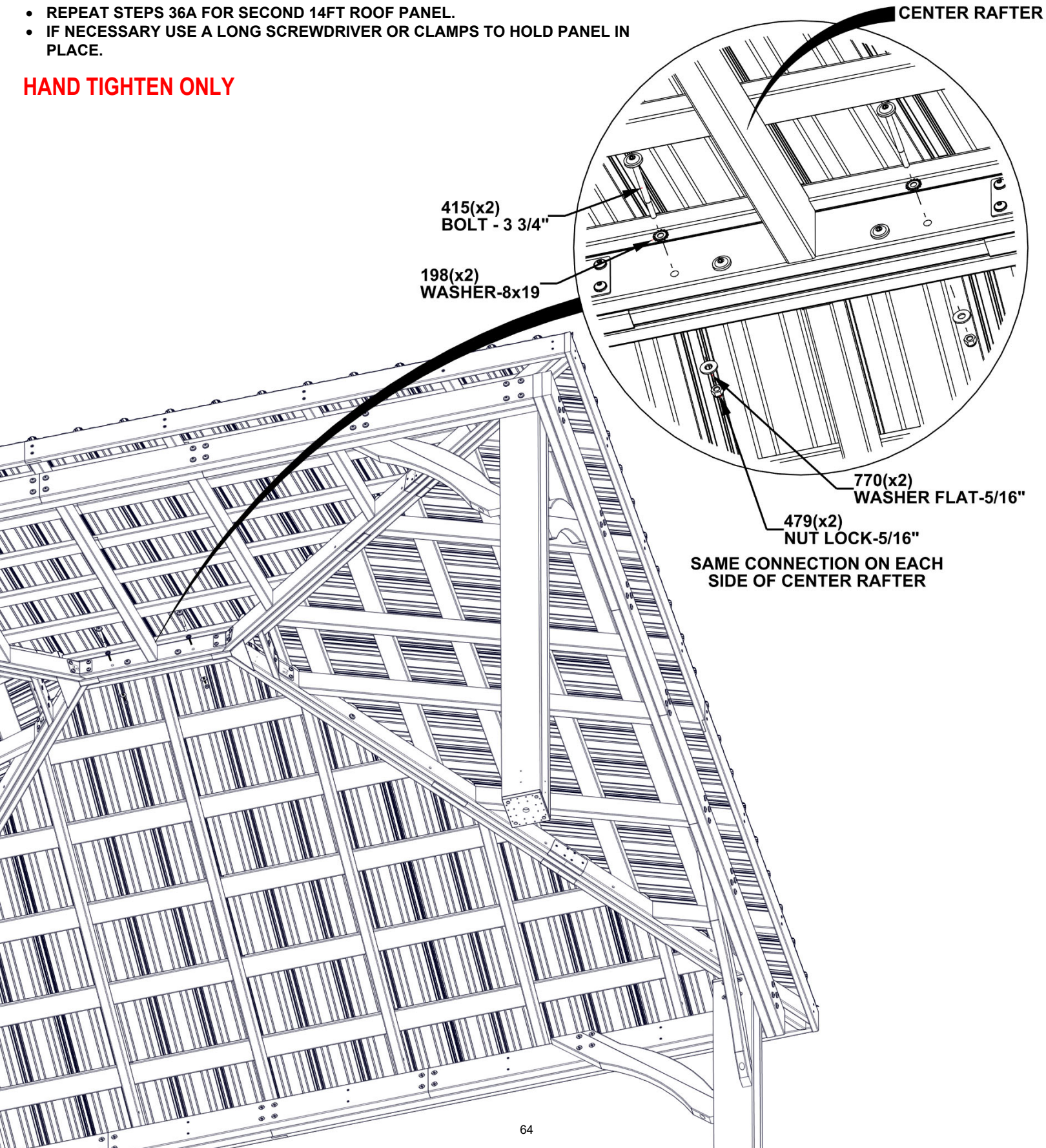

STEP 37B - 14FT ROOF PANEL ATTACHMENT

QTY	PART NUMBER	DESCRIPTION
16	H100198	WASHER LOCK EXT 8X19 BLK
16	H100415	BOLT WH 5/16x3 3/4 BLK
16	H100479	NUT LOCK 5/16 BLK
16	H100770	WASHER FLAT 5/16 BLK

HAND TIGHTEN ONLY

IF THE HOLES ARE SLIGHTLY UNALIGNED, DRIVE THE BOLT THROUGH THE (3) BOARDS USING A DRILL. THIS WILL ENABLE THE BOLTS TO SCREW INTO THE HOLES.

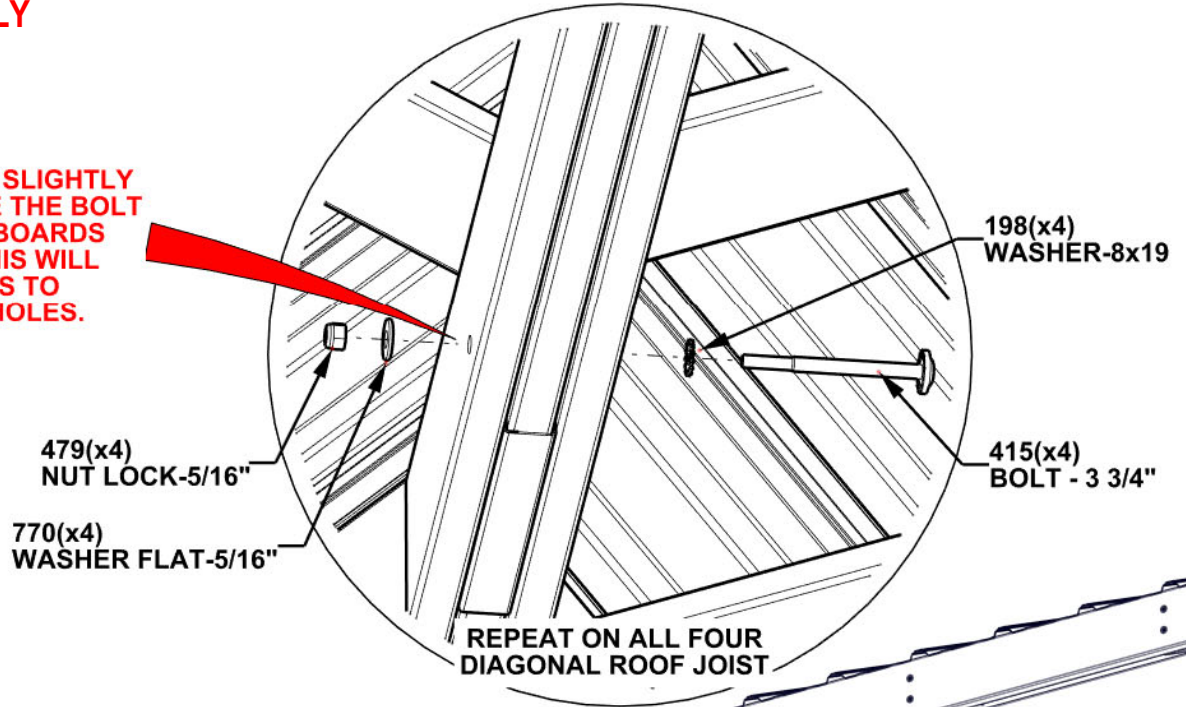

STEP 38 - ROOF PANEL ATTACHMENT

**TIGHTEN ALL THE HARDWARE IN THE ORDER SHOWN BELOW.
START AT THE TOP AND WORK YOUR WAY DOWN.**

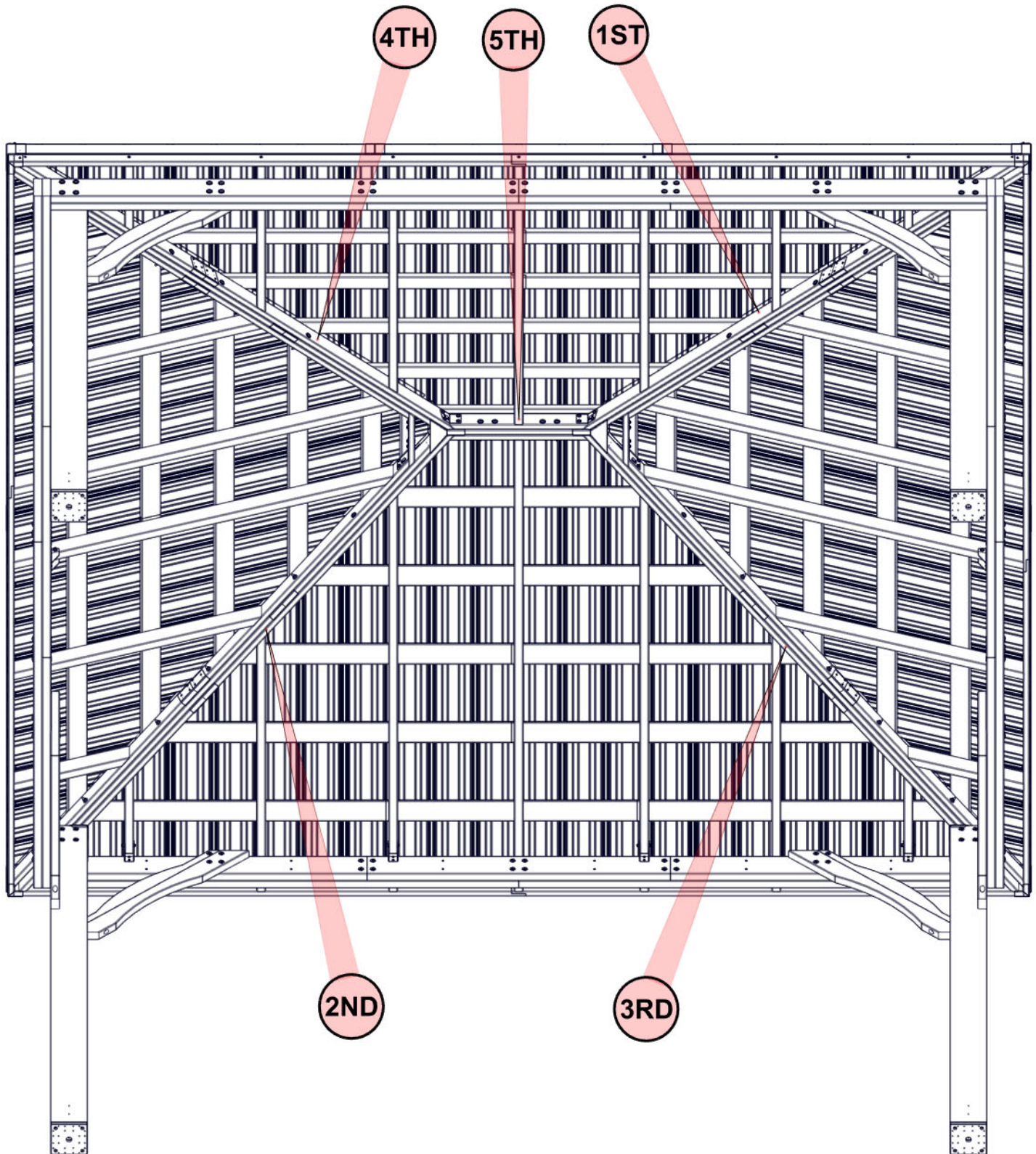

STEP 39 - ROOF ASSEMBLY

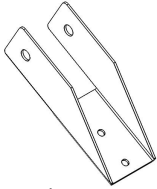

A4M01228 | RAFTER CLIP
(16)

QTY	PART NUMBER	DESCRIPTION
16	H100488	BOLT WH 1/4x2 BLK
32	H100536	SCREW PWH 8x1 1/4 BLK
16	H100630	WASHER FLAT 8x19 BLK
16	H100653	NUT LOCK 1/4 BLK

TIPS:

- ATTACH RAFTER CLIPS FIRST WITH 2" BOLTS.
- USING THE BRACKET AS A TEMPLATE AND A 1/8" DRILL BIT, DRILL PILOT HOLES FOR THE H100536 SCREWS.
- DRILL PILOT HOLES APPROXIMATELY 1/2" DEEP.
- NOTE THERE ARE NO RAFTER CLIPS WHERE CORBELS ARE LOCATED.

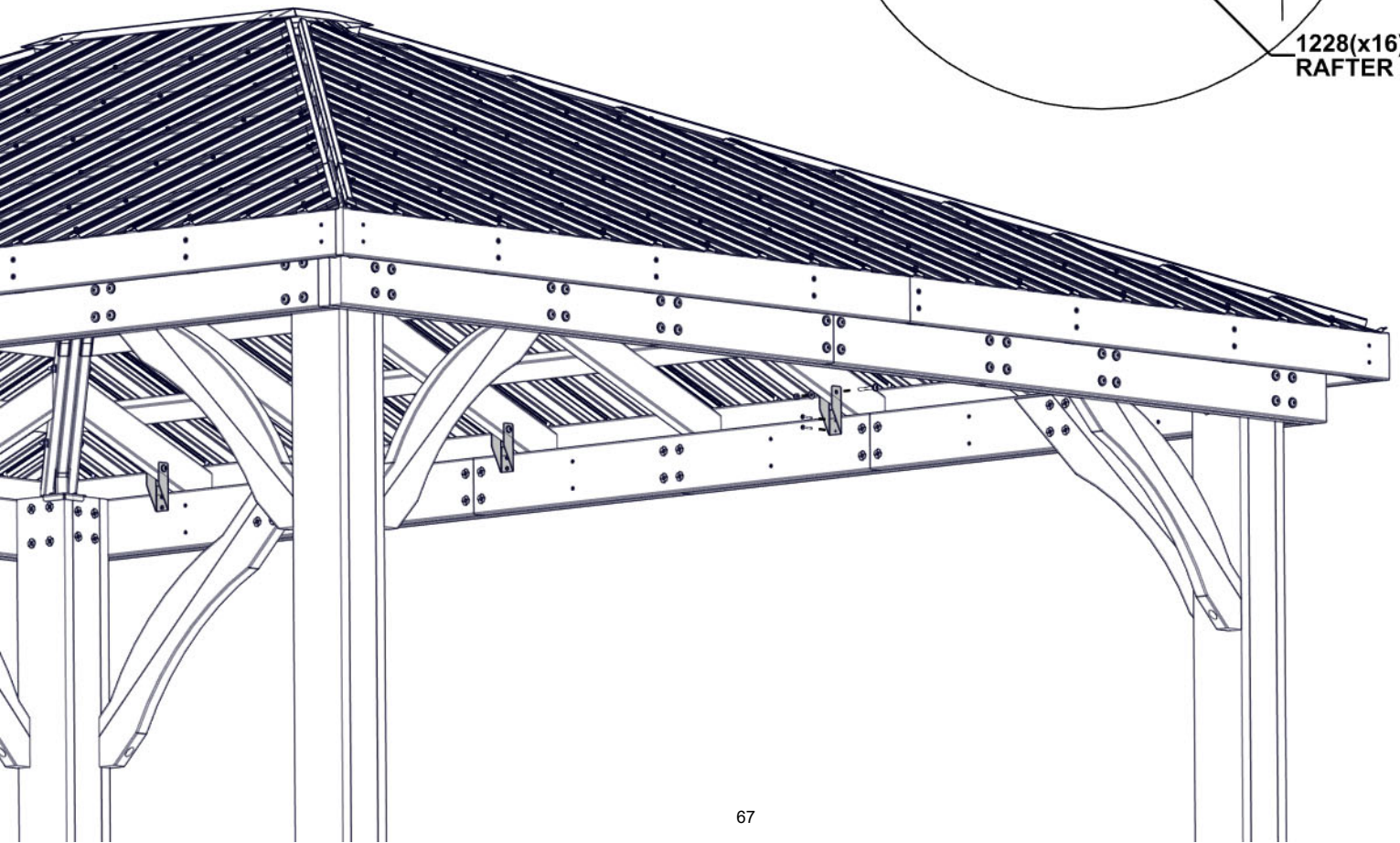
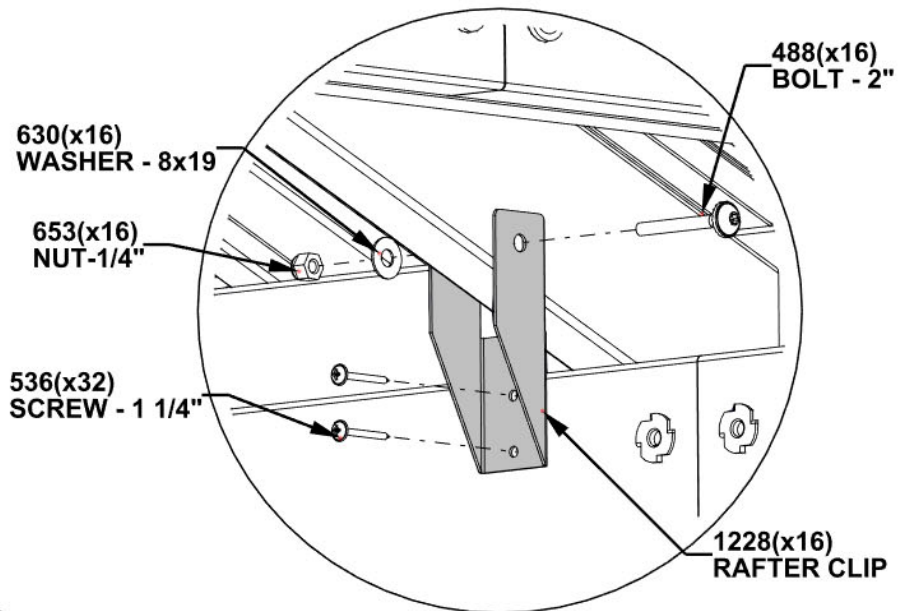

STEP 40 - ROOF ASSEMBLY

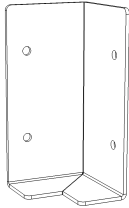

A4M01185
(4) CORNER BRACKET

QTY	PART NUMBER	DESCRIPTION
16	H100392	SCREW PWH 8x3/4 BLK

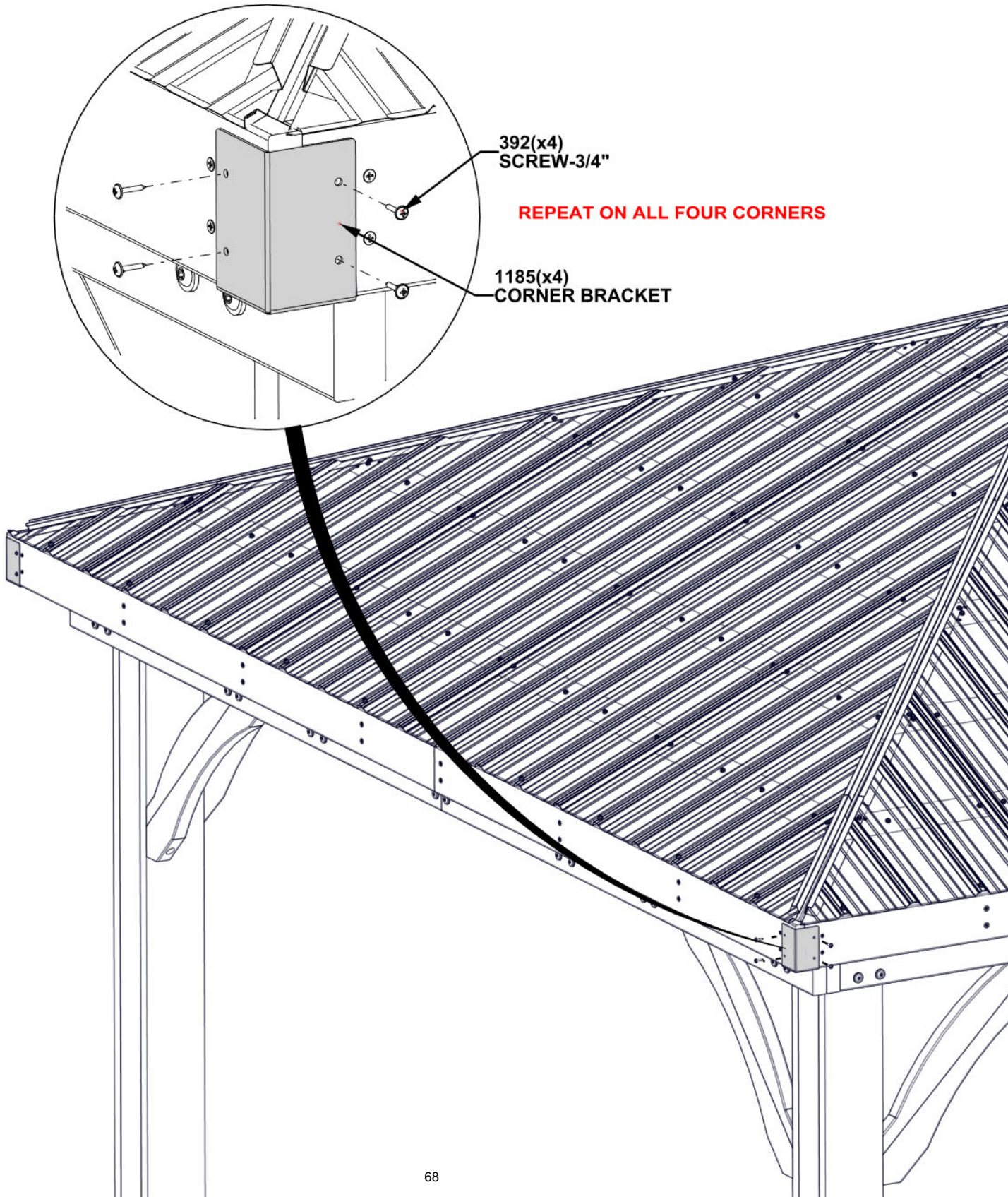

392(x4)
SCREW-3/4"

REPEAT ON ALL FOUR CORNERS

1185(x4)
CORNER BRACKET

STEP 41 - 14FT ROOF TRIM

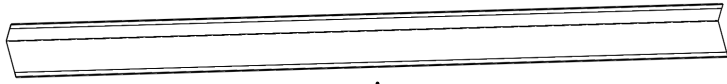

A4M02885
(4) | EDGE TRIM LONG

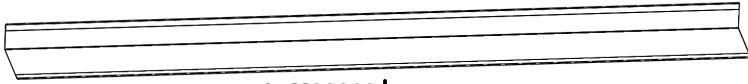

A4M02869
(2) | EDGE TRIM SHORT

QTY	PART NUMBER	DESCRIPTION
24	H100759	SCREW SELF TAPPING 1/4x1

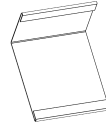

A4M02822
(4) | EDGE TRIM SPLICE

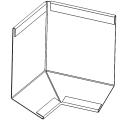

A4M02825
(4) | EDGE TRIM CORNER SPLICE

TIPS:

- START ON THE LEFT SIDE OF A 14FT PANEL.
- SLIDE EDGE TRIM PIECES TOGETHER AS SHOWN BELOW.
- MAKE SURE ALL PANELS ARE COVERED BEFORE INSTALLING SCREWS.
- INSTALL H100759 AS SHOWN

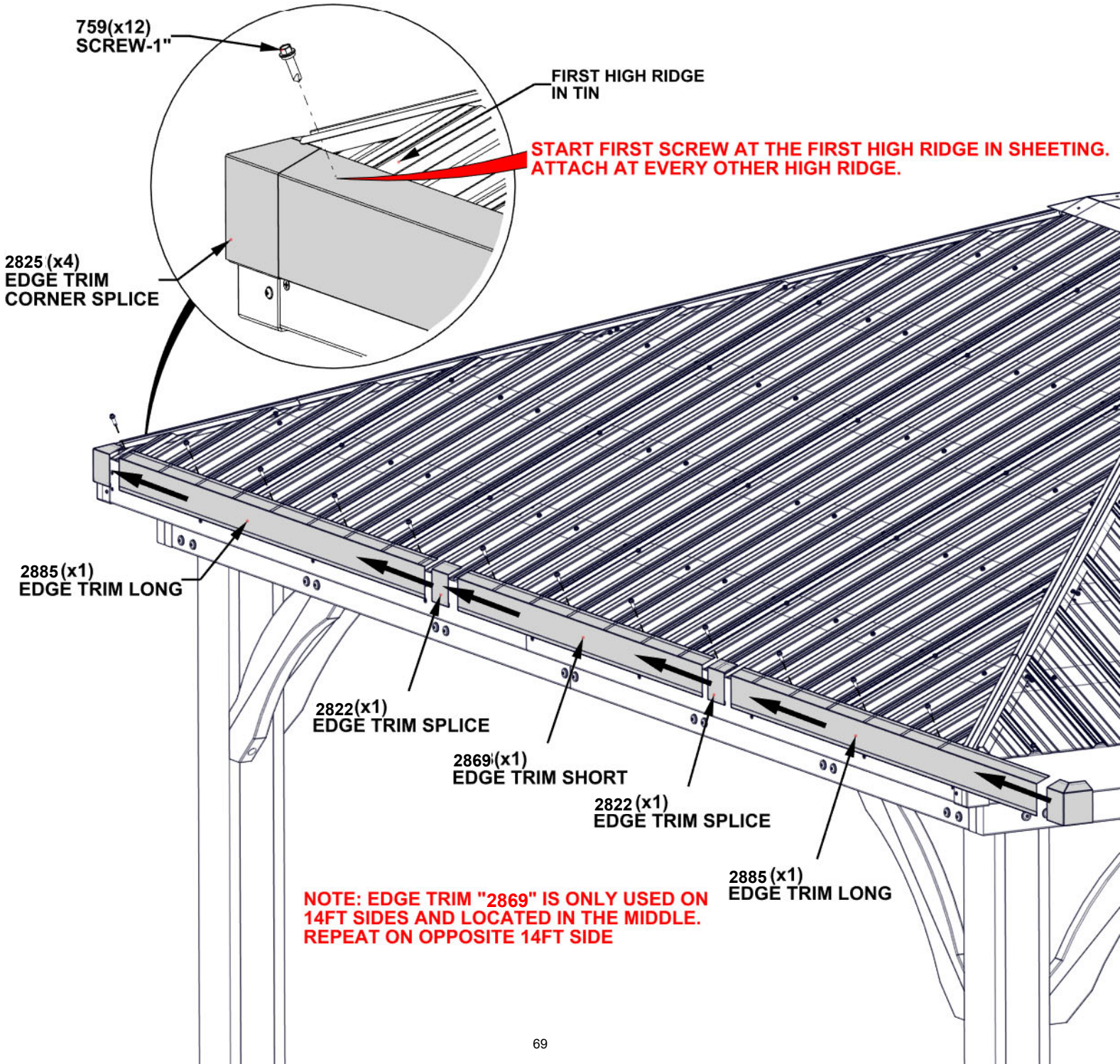

STEP 42 - 12FT ROOF TRIM

QTY	PART NUMBER	DESCRIPTION
20	H100759	SCREW SELF TAPPING 1/4x1



A4M02821 | EDGE TRIM LONG
(4)

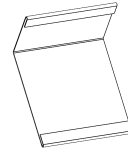

A4M02822 | EDGE TRIM SPLICE
(2)

TIPS:

- START ON THE LEFT SIDE OF A 12FT PANEL.
- SLIDE EDGE TRIM PIECES TOGETHER AS SHOWN BELOW.
- MAKE SURE ALL PANELS ARE COVERED BEFORE INSTALLING SCREWS.
- INSTALL H100759 SCREWS AS SHOWN.

759(x10)
SCREW-1"

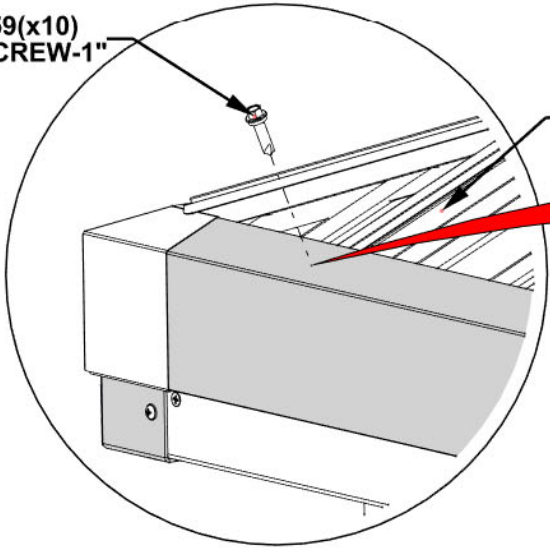

REPEAT ON OPPOSITE 12FT SIDE

FIRST HIGH RIDGE
IN SHEETING

**START FIRST SCREW AT THE FIRST HIGH RIDGE
IN SHEETING. ATTACH AT EVERY OTHER HIGH RIDGE**

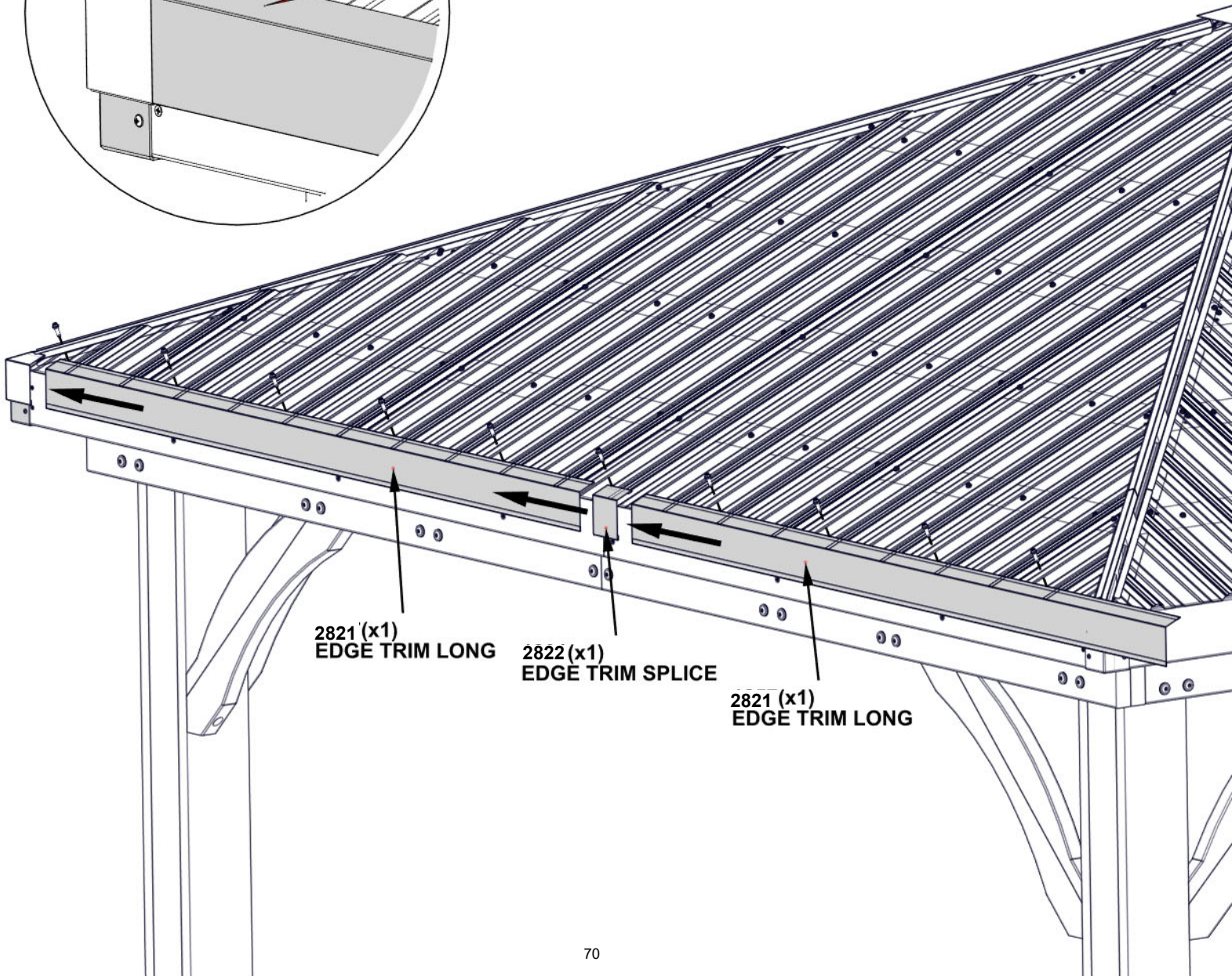

2821 (x1)
EDGE TRIM LONG

2822 (x1)
EDGE TRIM SPLICE

2821 (x1)
EDGE TRIM LONG

STEP 43 - ROOF ASSEMBLY

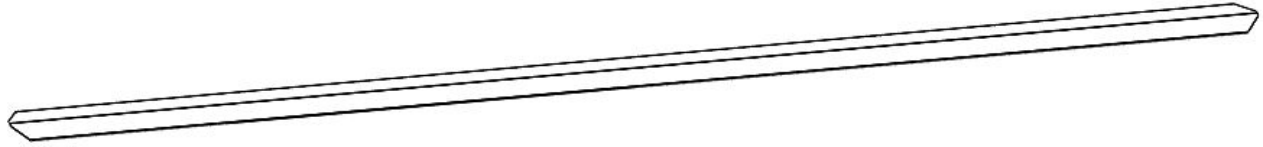

A4M02826 | CORNER RIDGE CAP LONG
(4)

- TIPS:
- SLIDE CORNER RIDGE CAP ONTO ROOF RIDGE CAP CHANNEL AS SHOWN.
 - DO NOT PUSH ALL THE WAY TO THE TOP. FLUSH WITH CORNER OF GAZEBO AS SHOWN.
 - REPEAT ON ALL CORNERS.

REPEAT ON ALL FOUR CORNERS

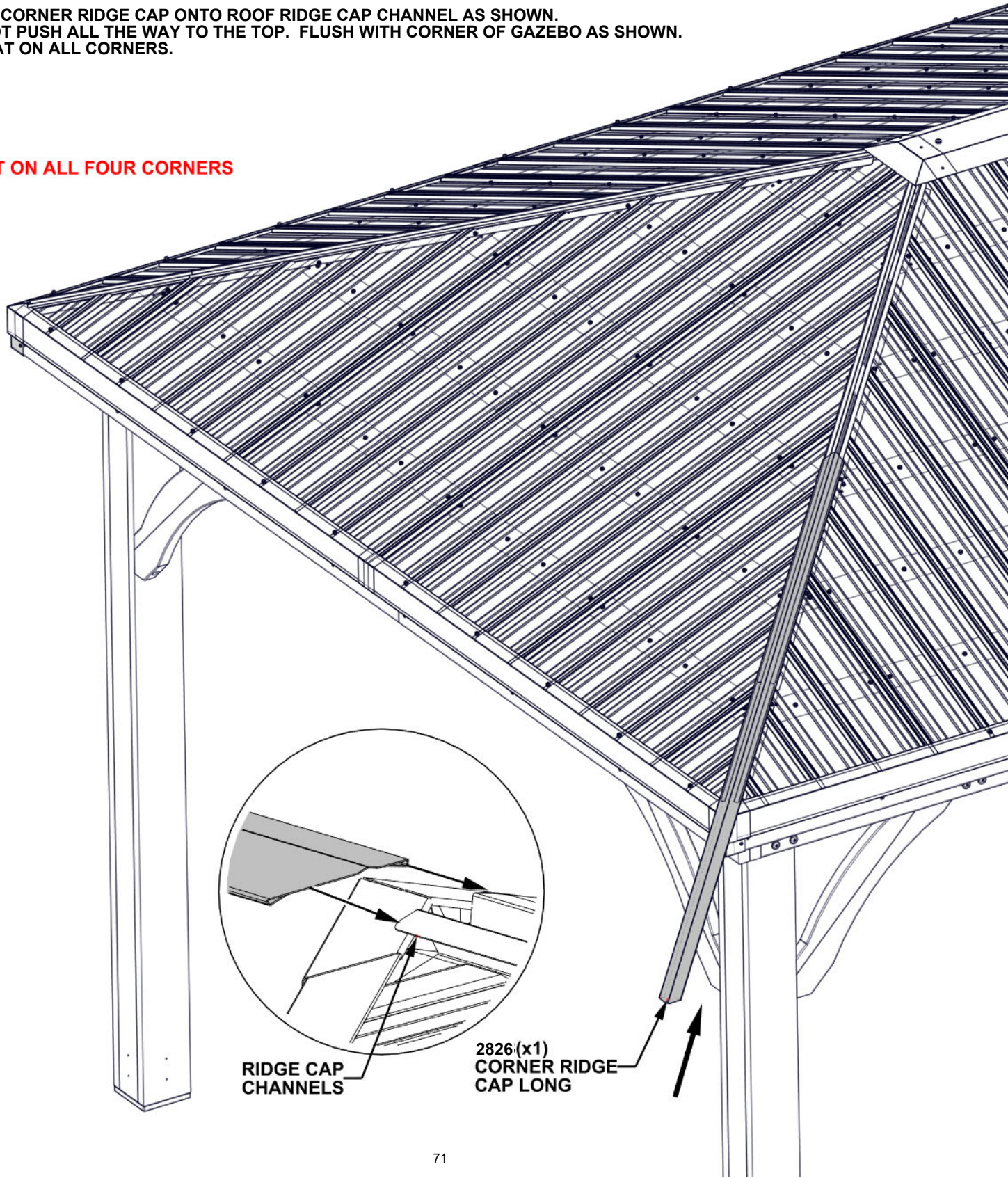

STEP 44 - ROOF ASSEMBLY

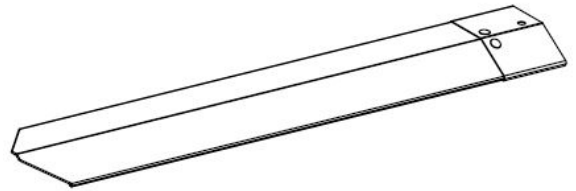

A4M02867 | RIDGE CAP SPLICE ASSEMBLY
(4)

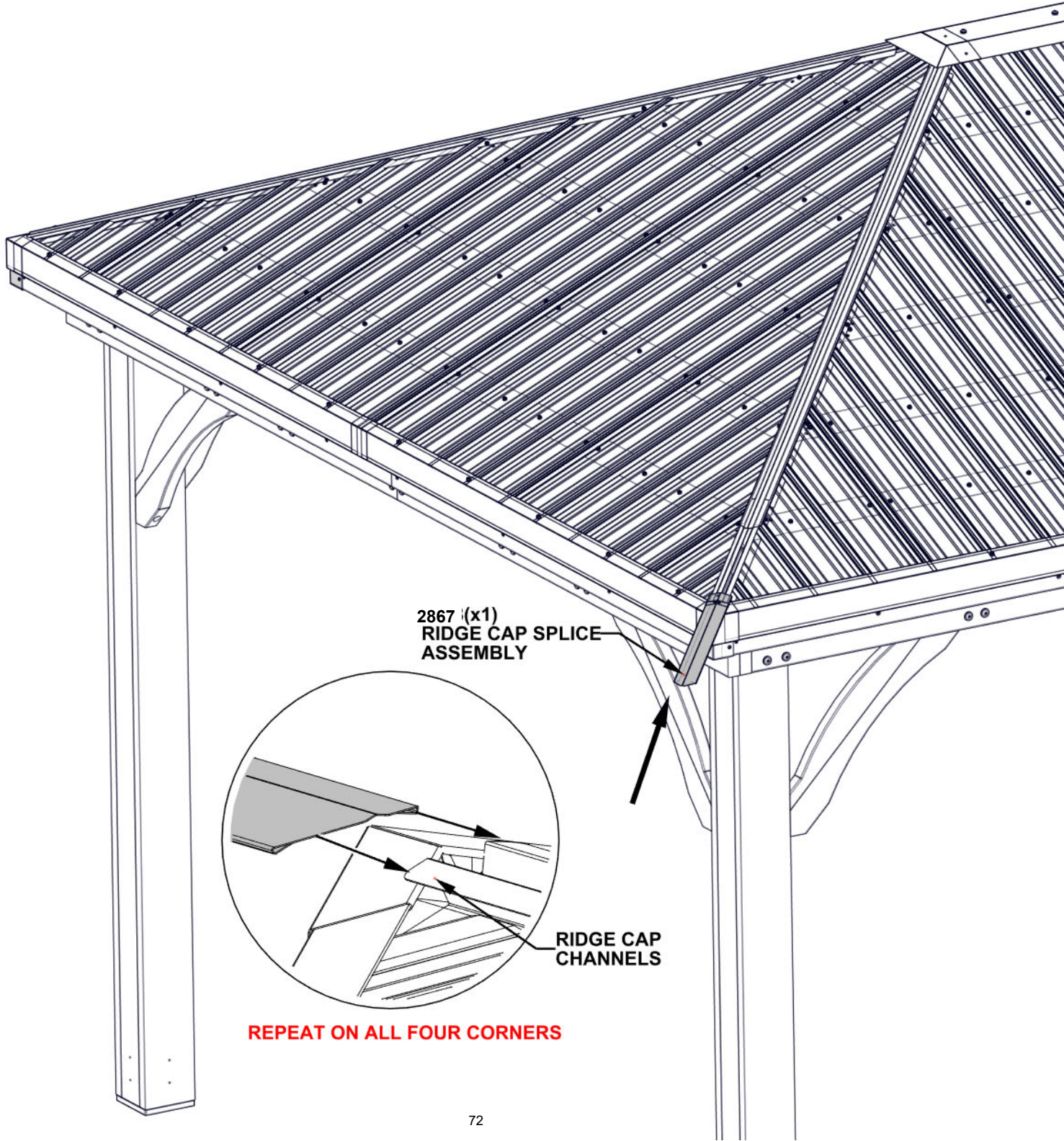

2867 (x1)
RIDGE CAP SPLICE
ASSEMBLY

RIDGE CAP
CHANNELS

REPEAT ON ALL FOUR CORNERS

STEP 45 - ROOF ASSEMBLY

QTY.	PART NUMBER	DESCRIPTION
12	H100759	SCREW SELF TAPPING 1/4x1

REPEAT ON ALL FOUR CORNERS

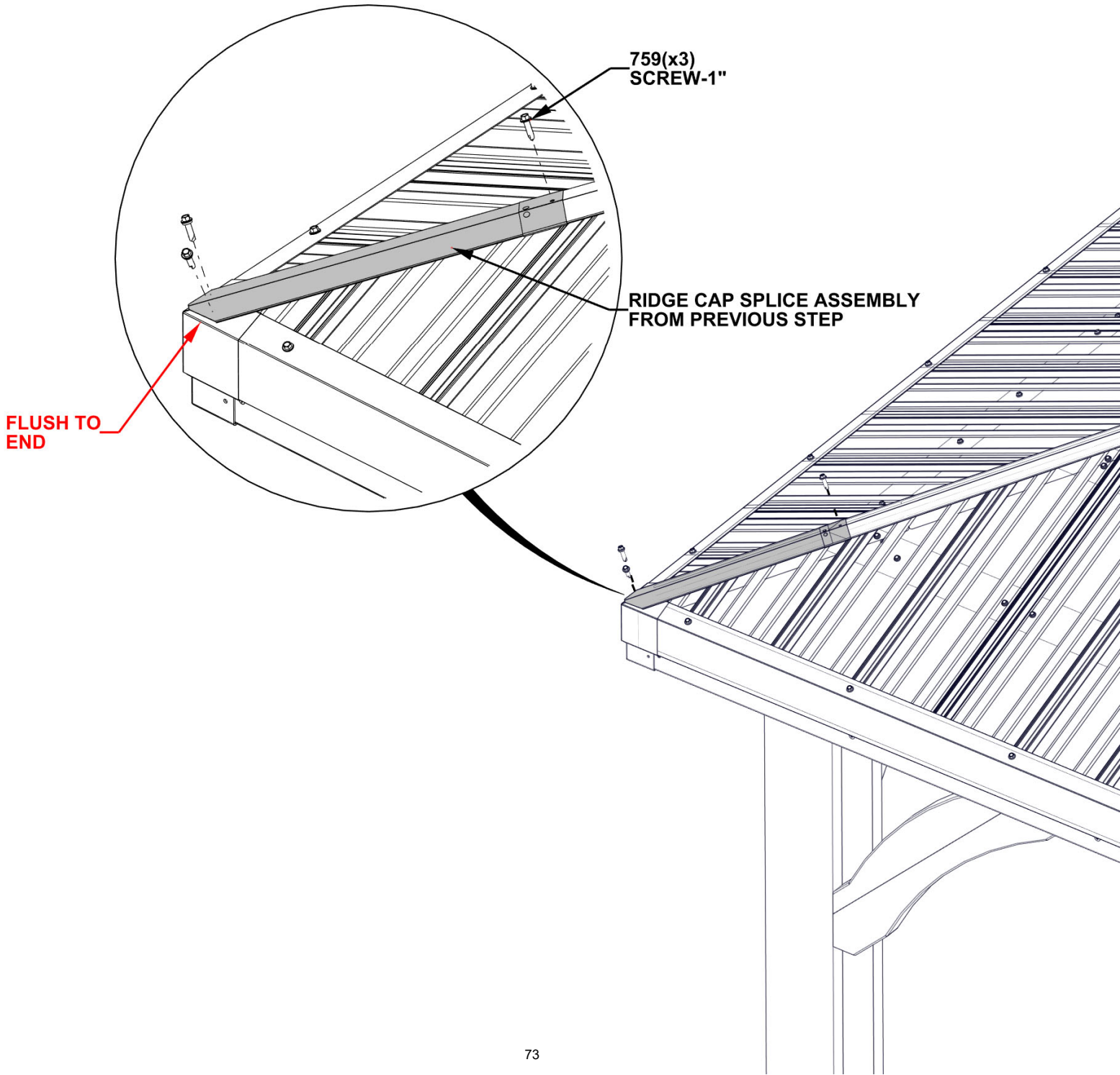

STEP 46 - GAZEBO ASSEMBLY

QTY.	PART NUMBER	DESCRIPTION
32	H100471	LAG SCREW WH 5/16x1 1/2 BLK

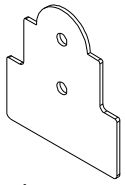

A4M01794
(8) **STEEL POST PLATE**

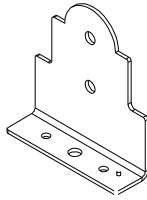

A4M01793
(8) **STEEL POST ANCHORING PLATE**

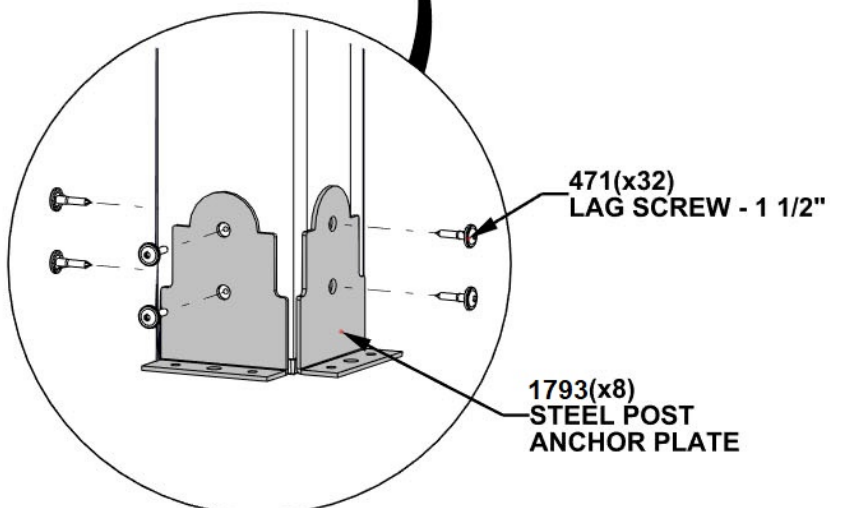
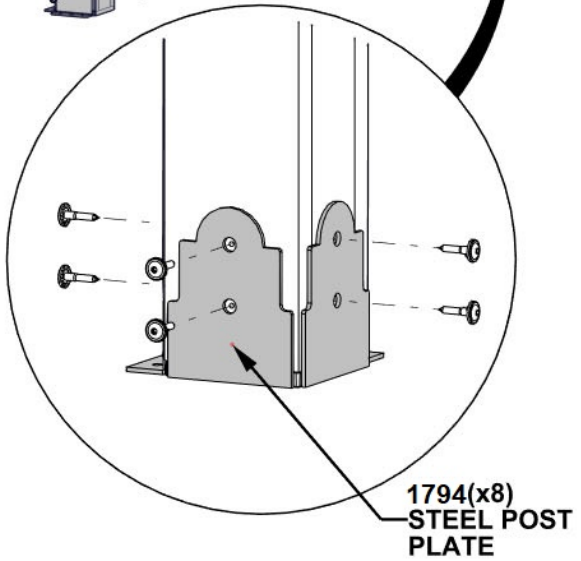
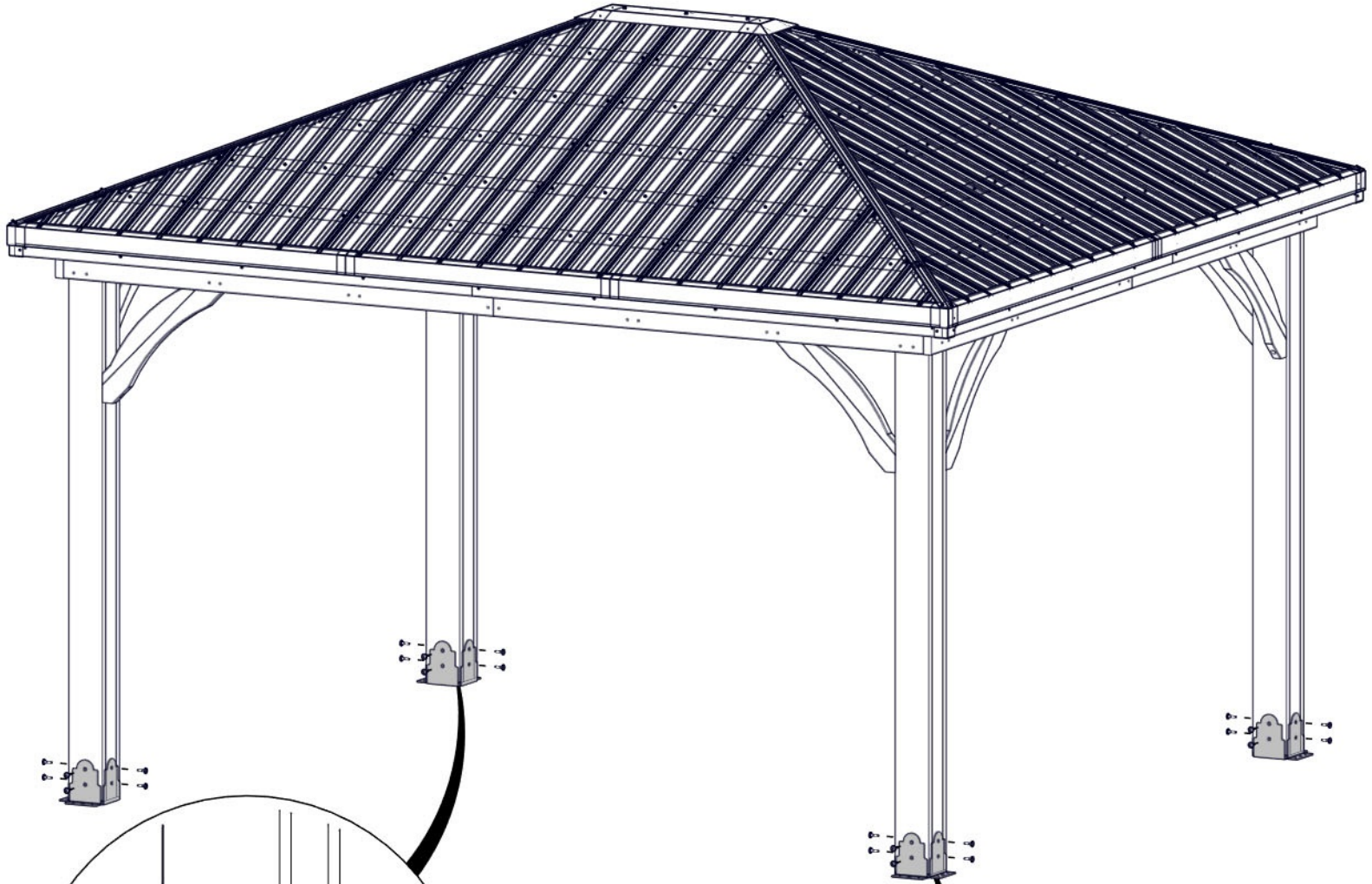

STEP 47 - GAZEBO ASSEMBLY



A4M02158
BYD ID TAG PATIO
(x1)

QTY	PART NUMBER	DESCRIPTION
4	H100536	SCREW PWH 8x1 1/4 BLK

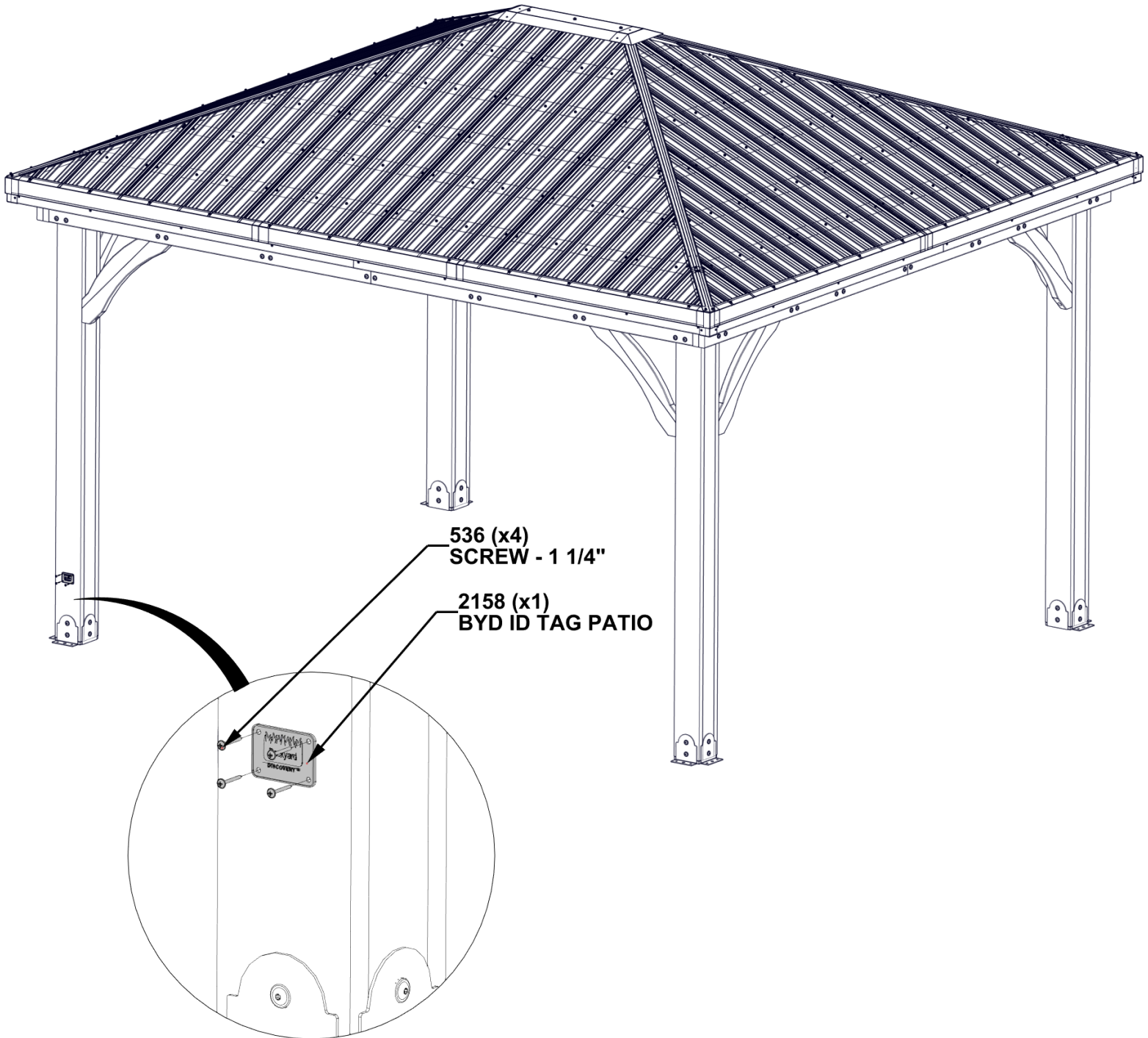

STEP 48 - GAZEBO ASSEMBLY

QTY	PART NUMBER	DESCRIPTION
16	H100630	WASHER FLAT 8x19 BLK
16	H100120	CONCRETE ANCHOR 1/4"x2"

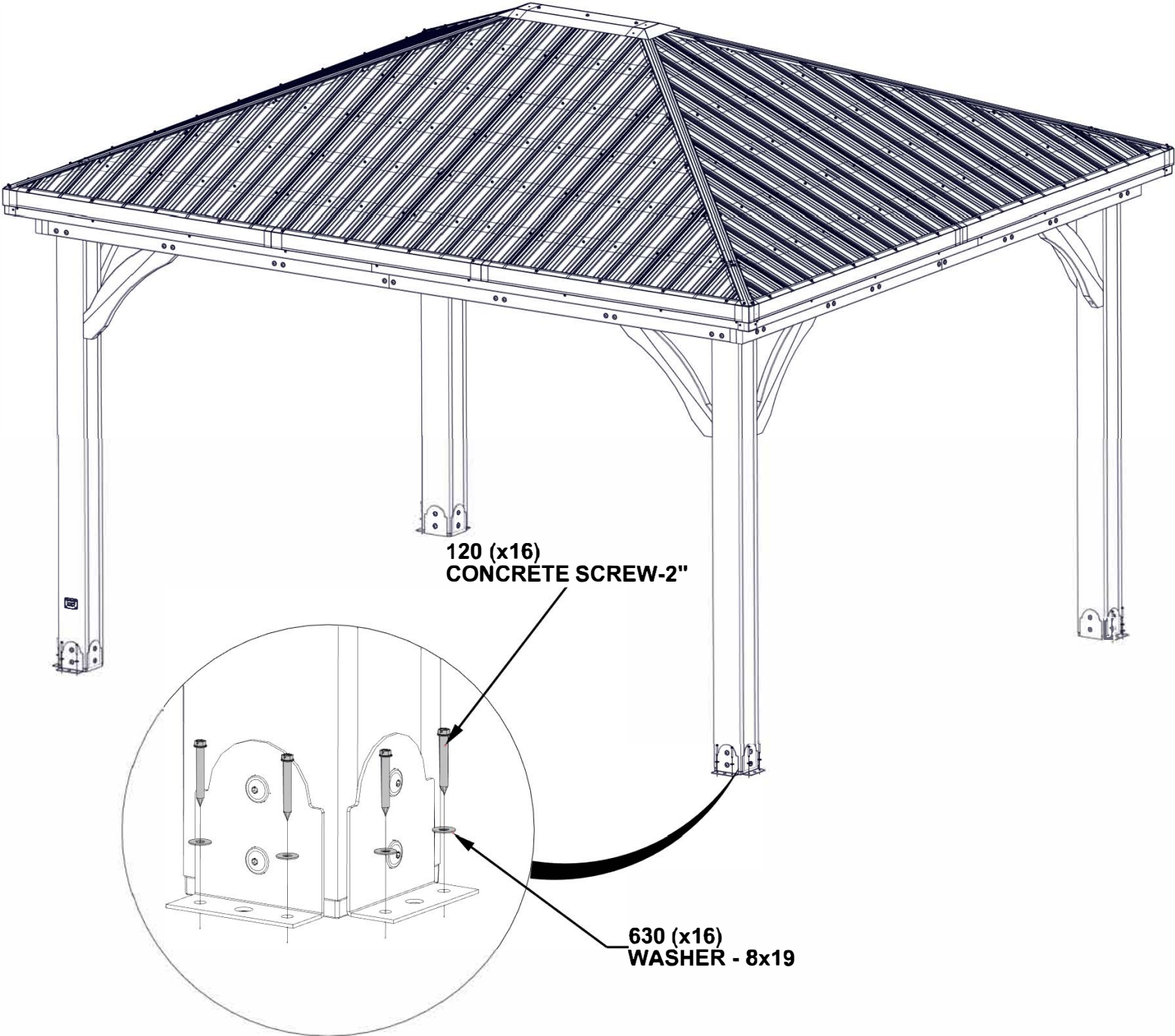

STEP 49 - GAZEBO ASSEMBLY (OPTIONAL)

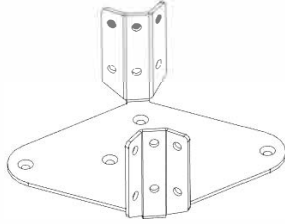

A4M02501 FAN MOUNT BRACKET
(x1)

QTY	PART NUMBER	DESCRIPTION
4	H100382	SCREW PFH 8x1 3/4 BLK

- ATTACH YOUR ELECTRICAL BOX (SOLD SEPERATELY) WITH THE PROVIDED HOLES IN FAN MOUNT BRACKET.
- PLACE FAN MOUNT BRACKET ON RIDGE BEAMS AND MOVE TO DESIRED FAN LOCATION.
- ROTATE BRACKET UNTIL MOUNTING FLANGES ALIGN BEST WITH RIDGE BEAMS.
- USE A 1/8" (3mm) DRILL BIT AND DRILL PILOT HOLES AND ATTACH AS SHOWN.

382 (x4)
SCREW - 1 3/4"

2501 (x1)
FAN MOUNT BRACKET

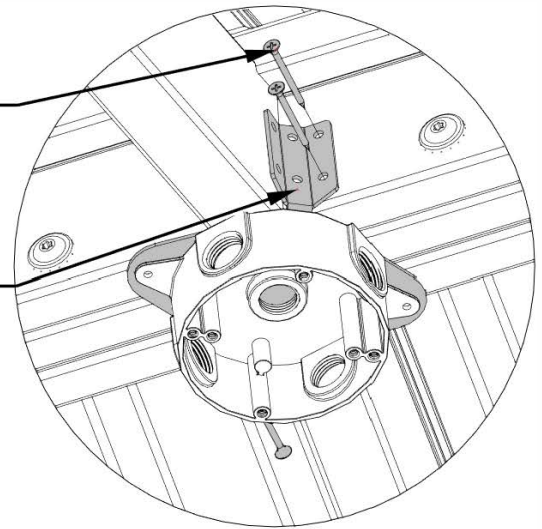

FAN MOUNT BRACKET

HARDWARE
BY
OTHERS

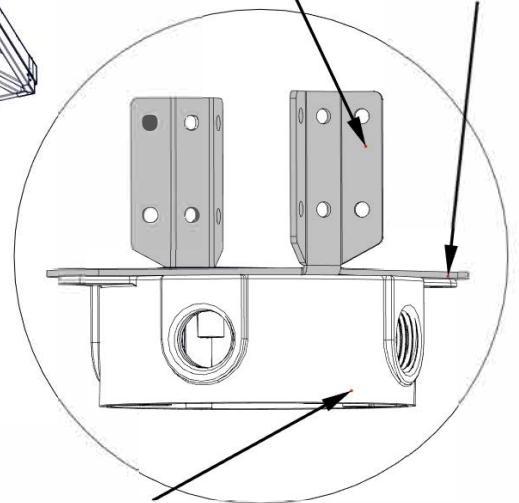

ELECTRICAL BOX
NOT INCLUDED

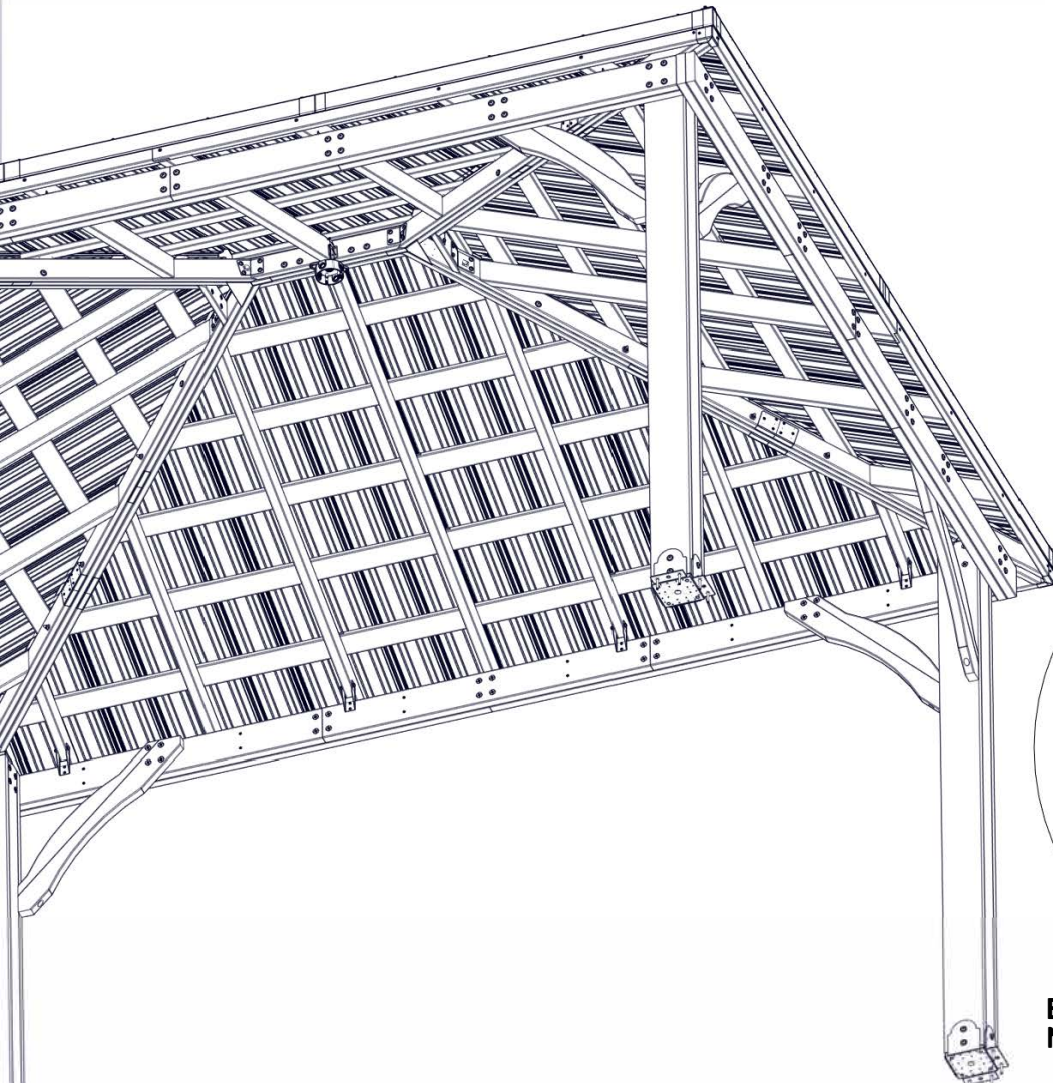

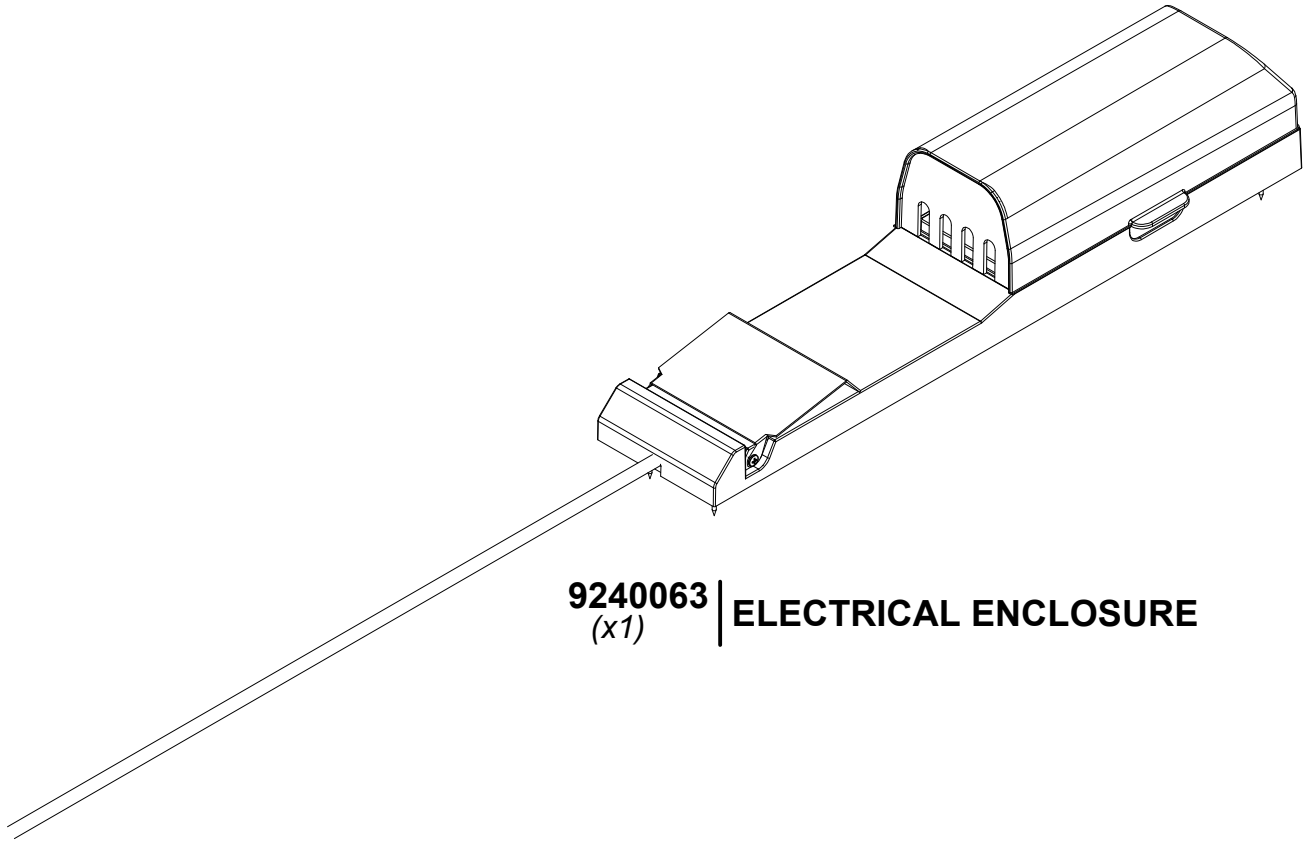

9240063 | **ELECTRICAL ENCLOSURE**
(x1)

FOR POWERPORT INSTALLATION REFER TO ASSEMBLY INSTRUCTIONS THAT COME PACKAGED WITH THE POWERPORT KIT. INSTALL ON ANY POST THAT IS DESIRED. FOLLOW DIRECTIONS FOR PROPER INSTALLATION.